

F.S. ROUTE NO.	SECTION	COUNTY	TOTAL SHEETS	SHEET
03-0718-00-BR	WAYNE		11	6
STA.	TO STA.			
FED. ROAD DIST. NO.	ILLINOIS	PROJECT	BR05-191 (S)	

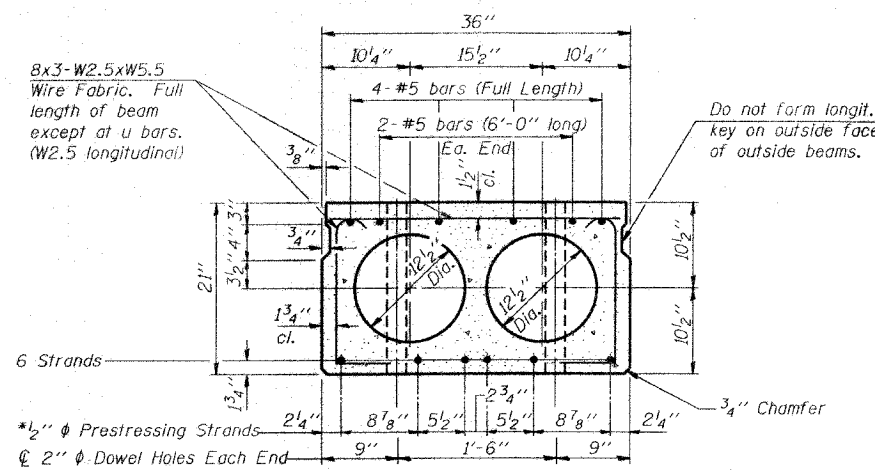

CROSS SECTION
(30' SPAN)

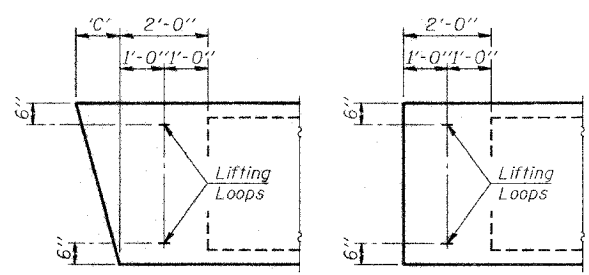

END BLOCK DETAILS

Each beam shall have four Lifting Loops, two at each end of beam cast in locations shown above. Loops shall be burned off after beams have been erected.

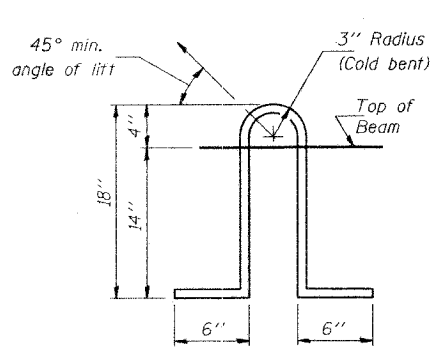

LIFTING LOOP DETAIL

Lifting loops shall be 2 1/2" phi - 270 ksi strands, as shown. Alternate approved lifting devices are also acceptable.

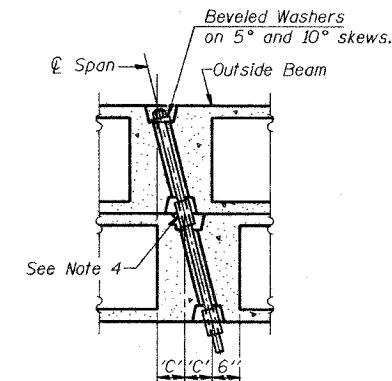

PARTIAL PLAN TRANSVERSE TIE ASSEMBLY
(D=0°, 5° and 10°)

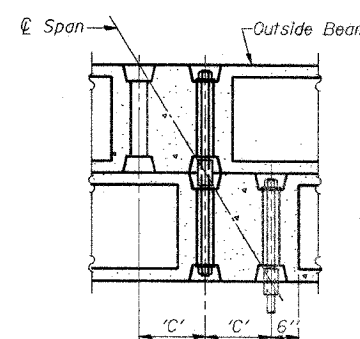

PARTIAL PLAN TRANSVERSE TIE ASSEMBLY
(D=15°, 20°, 25° and 30°)

DIMENSION 'C'

Skew Angle 'D'	0°	5°	10°	15°	20°	25°	30°
Dimension 'C' (Inches)	0	3 3/8	6 3/8	9 5/8	13 3/8	16 3/4	20 3/4

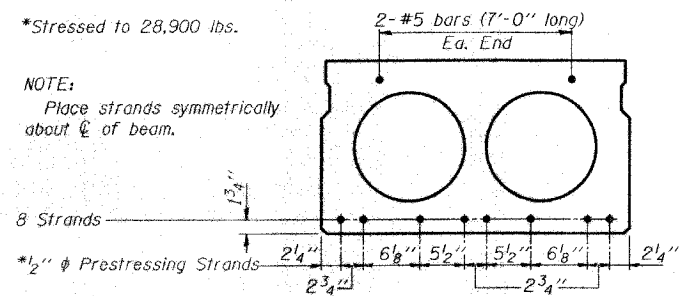

CROSS SECTION
(35' SPAN)

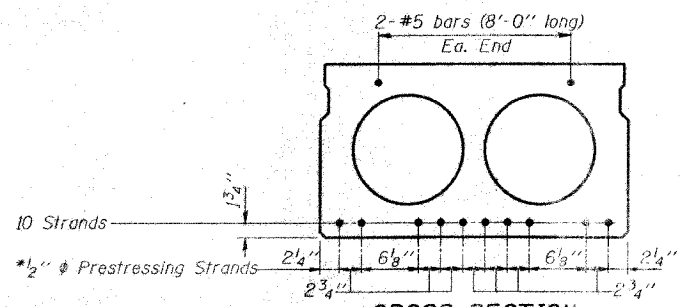

CROSS SECTION
(40' SPAN)

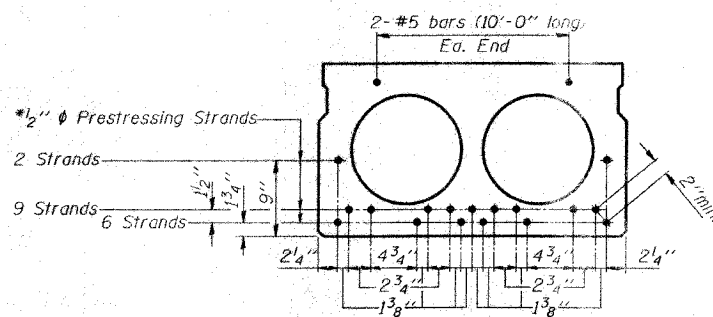

CROSS SECTION
(50' SPAN)

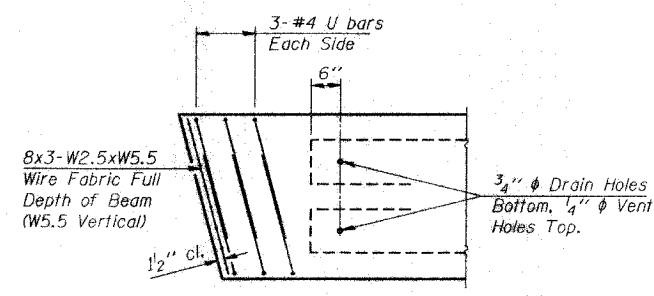

END REINFORCEMENT
(SKEWED)

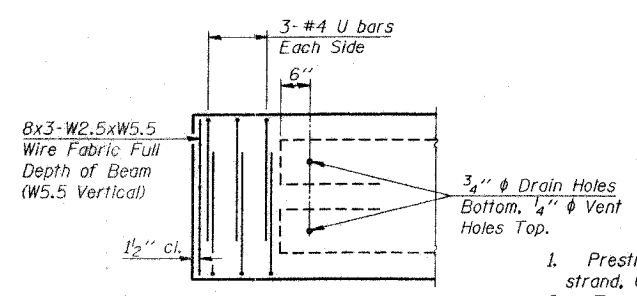

END REINFORCEMENT
(RIGHT ANGLE)

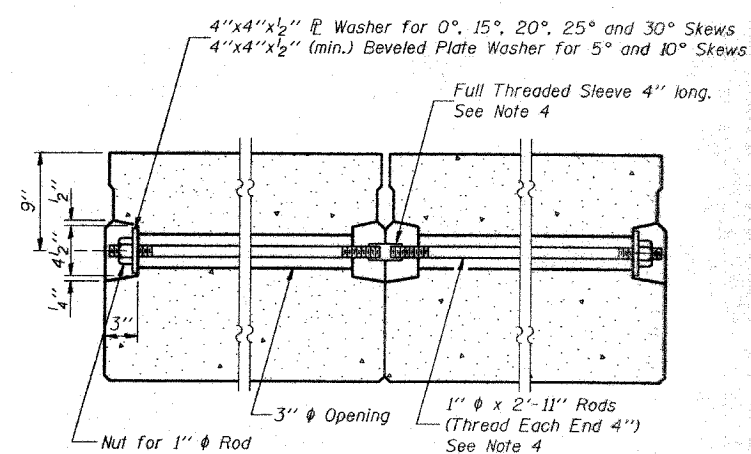

SECTION ALONG TRANSVERSE TIE ASSEMBLY
(REQUIRED FOR 50' SPAN ONLY)

NOTES

1. Prestressing steel shall be uncoated high strength, stress relieved 7-wire strand, Grade 270.
2. The nominal diameter shall be 1/2" and the nominal cross-sectional area shall be 0.153 square inches.
3. Reinforcement bars shall conform to AASHTO M-31 OR M-302 Grade 60.
4. On 0°, 5° and 10° skew, alternate approved transverse tie rods of increased segmental length are acceptable.
5. Rail Post anchor devices shall be cast into outside beam as elsewhere specified.
6. When Waterproofing Membrane System is specified, the top surface of the beams shall be finished in accordance with Article 504.06 of the Standard Specifications except that the surface shall not be roughened by brooming. The finished surface shall be free of depressions or high spots with sharp corners, and the top edge of keys shall be rounded or chamfered a minimum of 1/4".
7. Low relaxation strands may be substituted for the stress relieved strands. The initial prestressing force applied to each strand shall be the same as for the stress relieved strands (28,900 lbs.).
8. Keyway surfaces shall be cleaned to remove form oil or other bond breaking material prior to shipment of the beams. Cleaning shall be done by sandblasting the keyway areas between the top of the beam and the bottom edge of the key.

DESIGN STRESSES

$f_c = 5,000$ p.s.i.
 $f_{ci} =$ (See Required Release Strength Table) 4,000 p.s.i.
 $f_s = 270,000$ p.s.i. (1/2" phi Strand)
 $f_{si} = 201,960$ p.s.i. (1/2" phi Strand)
 $f_y = 60,000$ p.s.i.

REQUIRED RELEASE STRENGTH

Span	f_{ci} (psi)
30'	4,000
35'	4,000
40'	4,200
50'	4,100

Illinois Department of Transportation
 PASSED NOVEMBER 1, 1995
 [Signature]
 Engineer of Bridge Design
 APPROVED NOVEMBER 1, 1995
 [Signature]
 Engineer of Bridges and Structures

NOTE
 The std. reinf. shown on the 30' span cross section is typical for all spans, except as shown.

P.P.C. DECK BEAM DETAILS
 24' ROADWAY 21" x 36" BEAMS
 STANDARD CB-2421-36