

SIDEROAD AND ENTRANCE  
DETAILS

PAR. NO.	SECTION	COUNTY	TOTAL SHEETS	SHEET NO.
*	**	***	17	13
STA.		TO STA.		
FED. ROAD DIST. NO.		ILLINOIS	FED. AID PROJECT	

\* FAS 2882 (IL 371/FAS 905)  
 \*\* DS CONT. MAINT. FY 07-5  
 \*\*\* FRANKLIN & WILLIAMSON

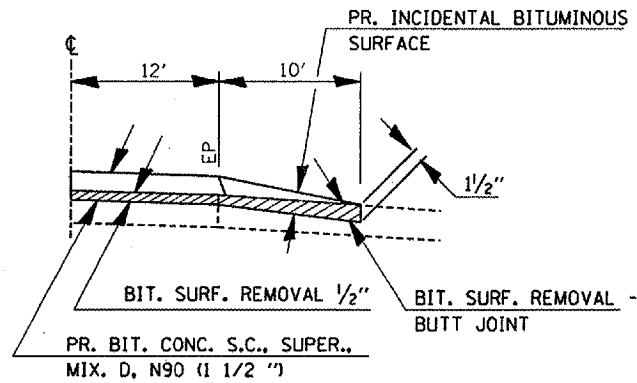

SIDE ROAD SEC. B-B  
EX. BIT. OR CONC. SURFACE

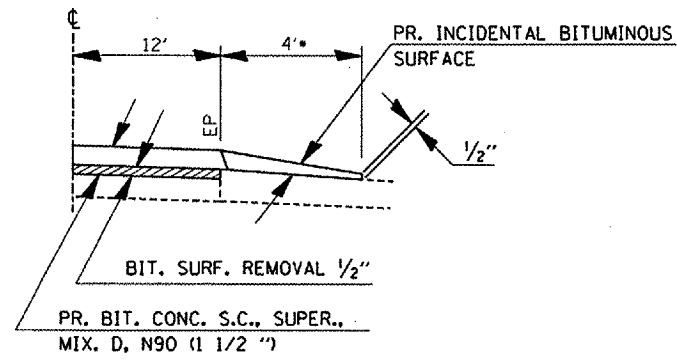

PE OR CE SEC. A-A  
EX. BIT. OR CONC. SURFACE  
OR END OF BIT. APRON

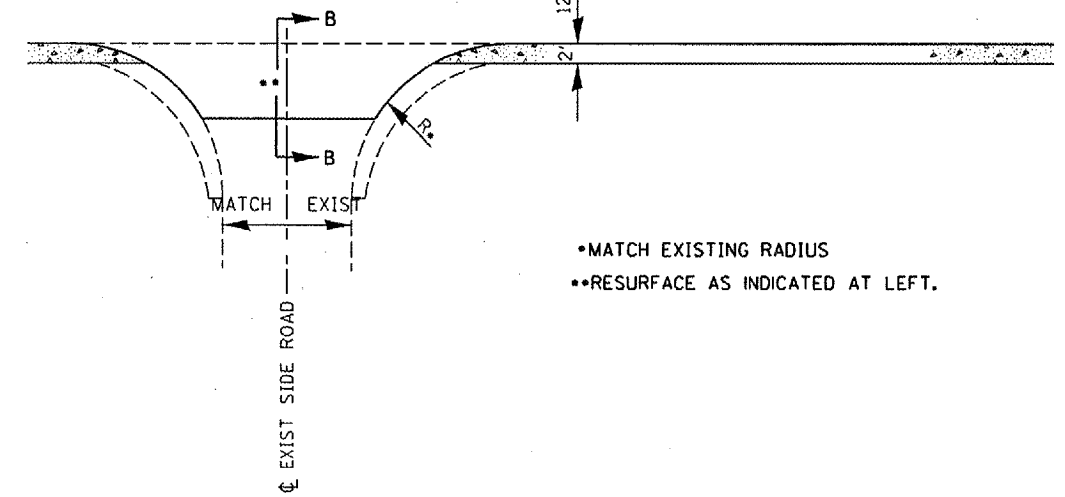
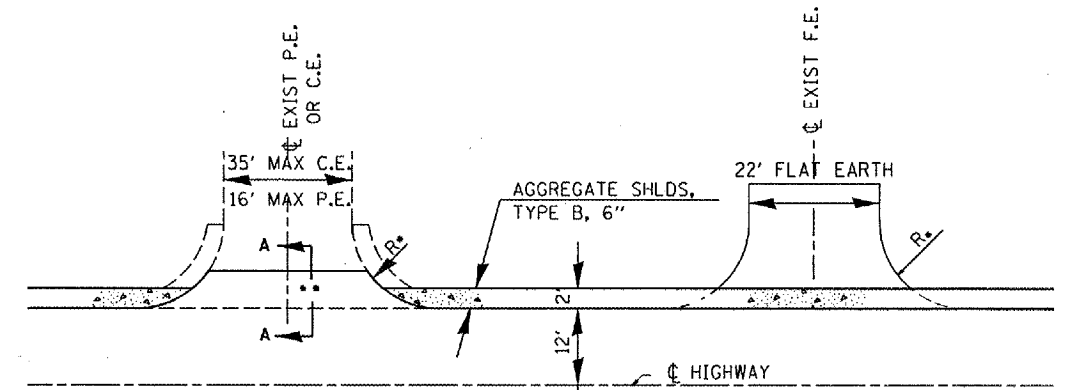

•MATCH EXISTING RADIUS  
 •RESURFACE AS INDICATED AT LEFT.

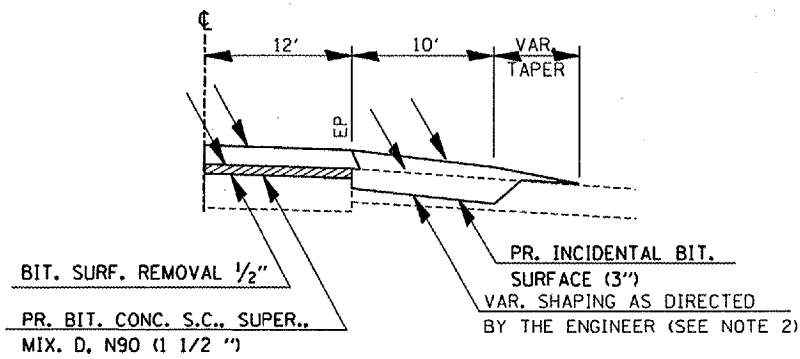

SIDE ROAD SEC. B-B  
EX. OIL & CHIP SURFACE  
(SEE NOTE 1)

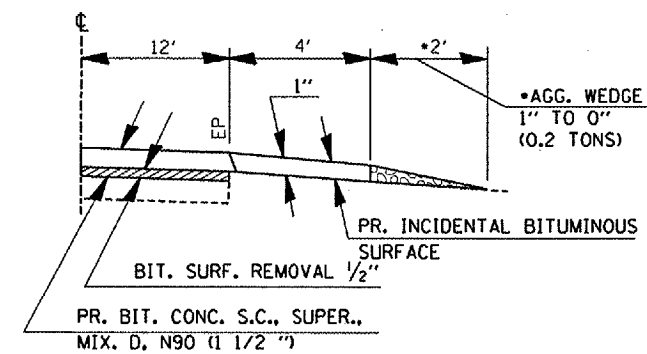

PE OR CE SEC. A-A  
EX. AGGREGTE SURFACE

NOTES

1. IF EXISTING SUBBASE IS INADEQUATE, AS DETERMINED BY THE ENGINEER, THE SIDE ROADS SHALL BE CORED OUT AND AGGREGATE SUBBASE, TYPE B SHALL BE PLACED FOR BASE. THE COST OF CORING OUT THE SIDE ROAD AND ANY AGGREGATE BASE COURSE SHALL BE PAID FOR AS SPECIFIED IN ART. 109.04 OF THE STANDARD SPECIFICATIONS FOR ROAD AND BRIDGE CONSTRUCTION. IF EXISTING SUBBASE IS DETERMINED TO BE ADEQUATE, THE PREPARATION OF THE BASE SHALL BE CONSTRUCTED ACCORDING TO ARTICLE 406.19.
2. VARIABLE SHAPING IS INCLUDED IN THE COST OF INCIDENTAL BITUMINOUS SURFACE.

ENTRANCE SCHEDULE

TYPE	NUMBER OF ENTRANCES
P.E.	11
C.E.	10
S.R.	4