

CONSTRUCTION CODE
CONTRACT MAINTENANCE
100% STATE
BOX CULVERT
0004
S.N. 050-2540

CODE NO.	ITEM	UNIT	TOTAL QUANTITY	
20400800	FURNISHED EXCAVATION	CUYD	151	151
28000400	PERIMETER EROSION BARRIER	FOOT	270	270
31100800	SUBBASE GRANULAR MATERIAL, TYPE A 9"	SQYD	276	276
42000060	WELDED WIRE REINFORCEMENT	SQYD	266	266
44200964	CLASS B PATCHES, TYPE IV, 9"	SQYD	266	266 
44201299	DOWEL BARS 1 1/2"	EACH	32	32
44213200	SAWCUTS	FOOT	398	398
44213204	TIE BARS 3/4"	EACH	26	26
48101200	AGGREGATE SHOULDERS, TYPE B	TON	24	24
50102400	CONCRETE REMOVAL	CUYD	62.9	62.9
50300225	CONCRETE STRUCTURES	CUYD	78.3	78.3
50300255	CONCRETE SUPERSTRUCTURE	CUYD	7	7
50800205	REINFORCEMENT BARS, EPOXY COATED	POUND	8650	8650
50800530	MECHANICAL SPLICERS	EACH	82	82

MODEL: D:\draft
 FILE NAME: p:\projects\p1\benley.com\p1\DOT\Documents\DOT Office\District 3\CRD Project\66N37\CADD\Sheet\66N37_LAN SET.dgn

USER NAME = ronak.woodshank	DESIGNED - RW	REVISED -
	DRAWN - RW	REVISED -
PLOT SCALE = 50.000 1/ in.	CHECKED - yp	REVISED -
PLOT DATE = 5/17/2023	DATE - 9/26/2022	REVISED -

**STATE OF ILLINOIS
DEPARTMENT OF TRANSPORTATION**

SUMMARY OF QUANTITIES

SCALE: 50 | SHEET 1 OF 3 SHEETS | STA. TO STA.

F.A.P. RTE.	SECTION	COUNTY	TOTAL SHEETS	SHEET NO.
786	(111)CLV-2	LASALLE	18	3
ILLINOIS FED. AID PROJECT			CONTRACT NO. 66N37	

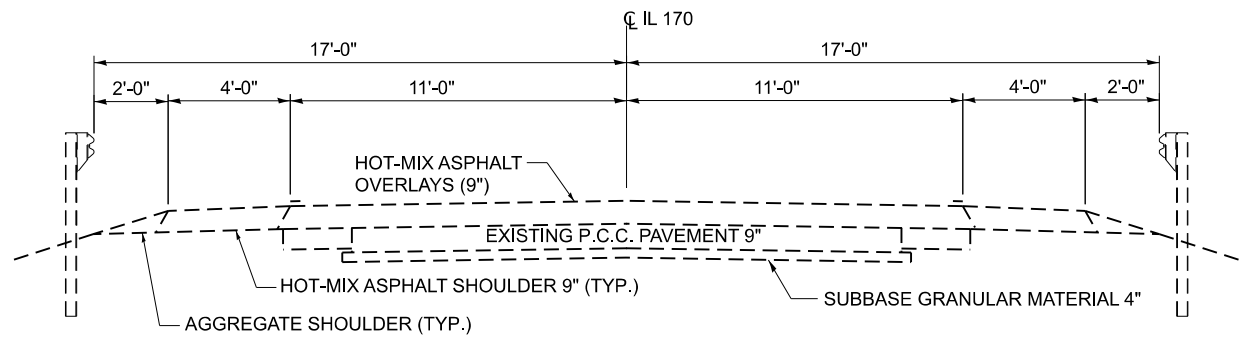

EXISTING ROADWAY TYPICAL SECTION

AT RT. Δ's TO CL ROADWAY
LOOKING SOUTH

MODEL: D:\info\...
 FILE NAME: ...
 PROJECT: ...
 USER: ...
 DATE: ...

USER NAME = ronald.woodshank	DESIGNED - RW	REVISED -
DRAWN - RW	REVISIONS -	
PLOT SCALE = 100,000' / 1"	CHECKED - YP	REVISED -
PLOT DATE = 7/24/2023	DATE - 9/26/2022	REVISED -

**STATE OF ILLINOIS
DEPARTMENT OF TRANSPORTATION**

TYPICAL SECTION

SCALE: 50 SHEET 1 OF 1 SHEETS STA. TO STA.

F.A.P. RTE.	SECTION	COUNTY	TOTAL SHEETS	SHEET NO.
786	(111)CLV-2	LASALLE	18	6
CONTRACT NO. 66N37				
ILLINOIS FED. AID PROJECT				