

F. A. L. SHEET NO.	SECTION	COUNTY	TOTAL SHEETS	SHEET NO.
55	2003-118 GRR	WILL	14	10
STA.	TO STA.			
FED. ROAD DIST. NO. 1	ILLINOIS	FED. AID PROJECT		

CONTRACT 62884

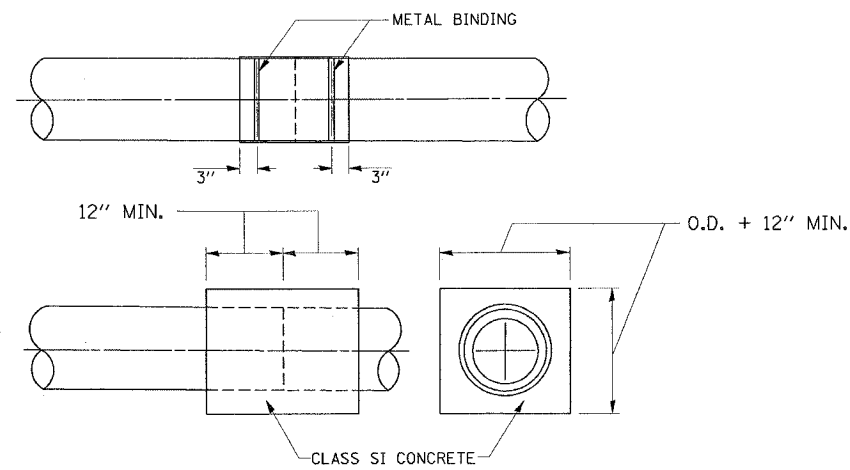

CLASS SI CONCRETE COLLAR

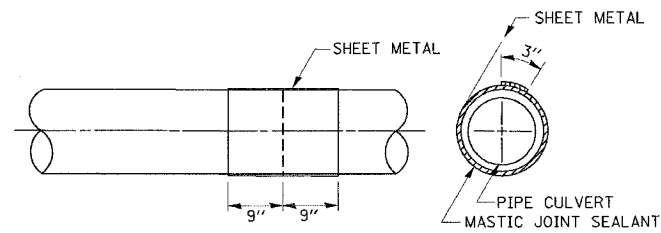
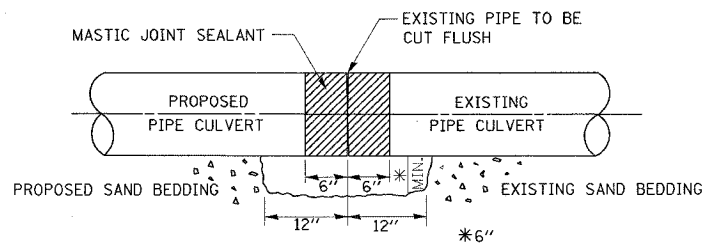
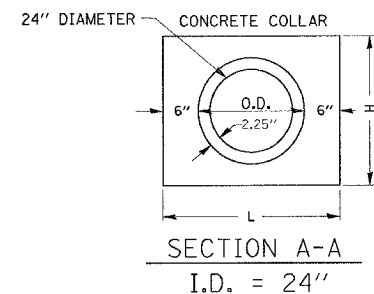
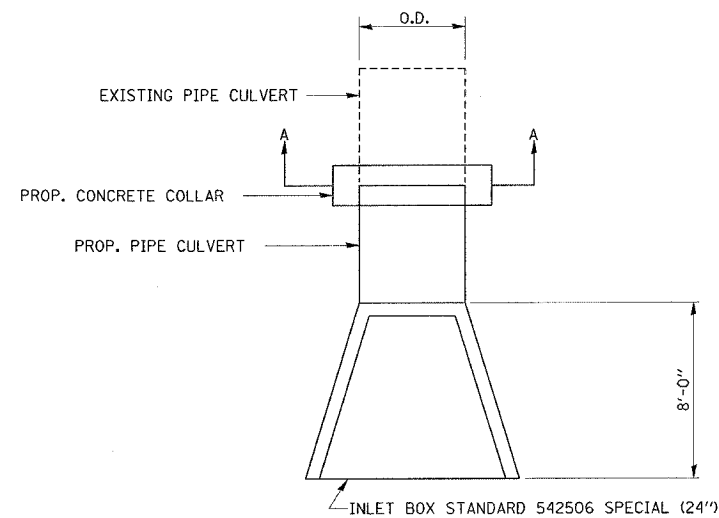

STATION	PIPE DIA. (in.)	L (FT.)	H (in.)	VOL. (CU. YD.)	NO. OF COLLARS (EACH)
**	24	3.375	40.50	.30	4

NOTES

** PIPE UNDERDRAIN/PIPE CULVERT TO BE FIELD LOCATED BY THE CONTRACTOR AND AS DIRECTED BY THE ENGINEER

GENERAL

- CARE MUST BE TAKEN TO PREVENT DEBRIS FROM ENTERING THE PIPE CULVERT. ALL DEBRIS WHICH ENTERS THE PIPE CULVERT MUST BE REMOVED. THE PIPE CULVERT MUST BE LEFT CLEAN AND UNOBSTRUCTED UPON COMPLETION OF THE CONTRACT.
- CARE MUST BE TAKEN TO PREVENT ANY PART OF THE NEW PIPE CONNECTION FROM PROJECTING INTO THE EXISTING SEWER.

BASIS OF PAYMENT

THE WORK FOR CONNECTING A PROPOSED PIPE CULVERT TO AN EXISTING PIPE CULVERT AS SHOWN IN THIS DETAIL SHALL BE PAID FOR AT THE CONTRACT UNIT PRICE PER EACH AS CONCRETE COLLAR WHICH PRICE SHALL INCLUDE ALL EQUIPMENT, LABOR, AND MATERIALS REQUIRED TO CONSTRUCT THE PROPOSED CONCRETE COLLAR.

CONSTRUCTION SEQUENCE:

- CUT THE EXISTING END OF THE PIPE SO AS TO PRESENT A FLUSH BUTT JOINT. BRUSH AND CLEAN ALL PIPES.
- APPLY THE MASTIC JOINT SEALANT TO THE FIRST 6" OF EACH PIPE.
- BUTT THE PIPES TOGETHER LEAVING A MINIMUM OF 12" x 6" DEEP EXCAVATION UNDER AND AROUND EACH PIPE END.
- CUT A PIECE OF SHEET METAL GAGE NO. 0.0418 18" WIDE BY THE OUTSIDE CIRCUMFERENCE OF THE PIPE PLUS 3" LONG.
- WRAP THE SHEET METAL AROUND THE PIPES, 9" ON EACH SIDE OF THE JOINT, STARTING AT THE TOP OF THE PIPE.
- LAP THE SHEET METAL AT LEAST 3" AT THE TOP OF THE PIPE AND PLACE THE MASTIC JOINT SEALANT BETWEEN THE LAP.
- PLACE TWO METAL BANDS AROUND THE SHEET METAL AND TIGHTEN.
- WIPE OFF ANY EXCESS MASTIC JOINT SEALANT THAT OZES OUT FROM BETWEEN THE SHEET METAL AND THE PIPES.
- PLACE CLASS SI CONCRETE AROUND THE JOINT.

NAME	DATE

ILLINOIS DEPARTMENT OF TRANSPORTATION

CONCRETE COLLAR AND INLET BOX DETAILS

SCALE: NONE
DATE 6/14/2005

DRAWN BY HMO
CHECKED BY

07:14:00 72:11:00