

STATE OF ILLINOIS  
DEPARTMENT OF TRANSPORTATION

ROUTE NO.	SECTION	COUNTY	TOTAL SHEETS	SHEET NO.	SHEET NO. 8
F. A. I. 80/94		COOK	90	65	21 SHEETS
FED. ROAD DIST. NO. 1		ILLINOIS FED. AID PROJECT-			
2004-133F		CONTRACT NO. 62898			

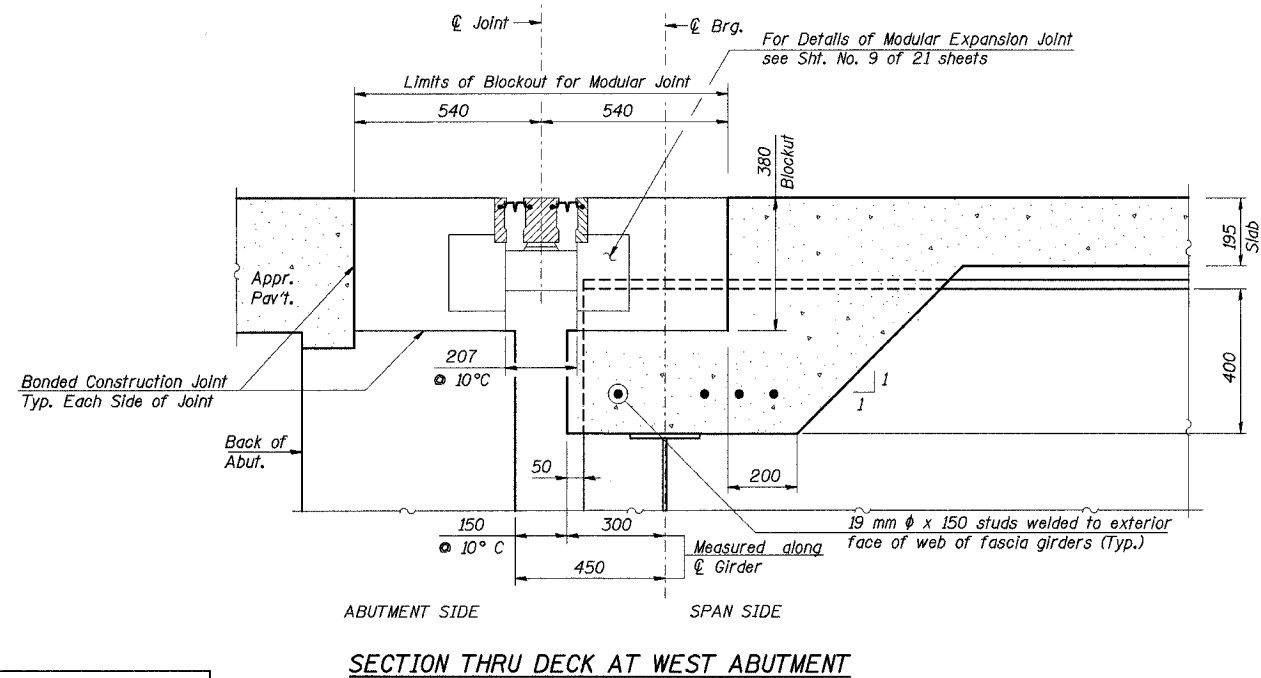
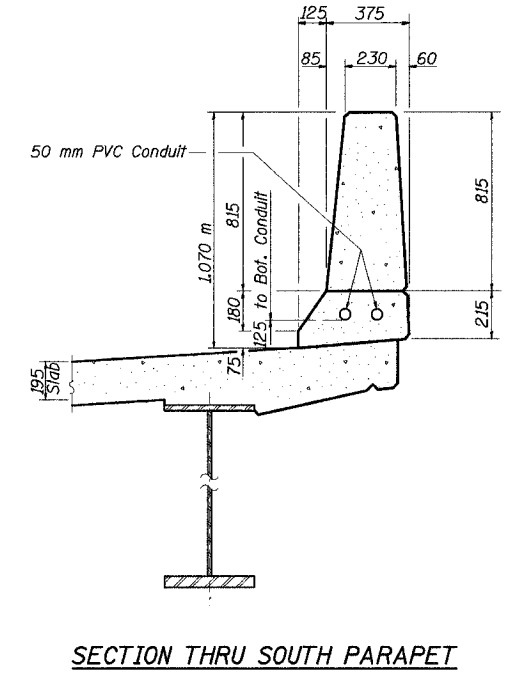
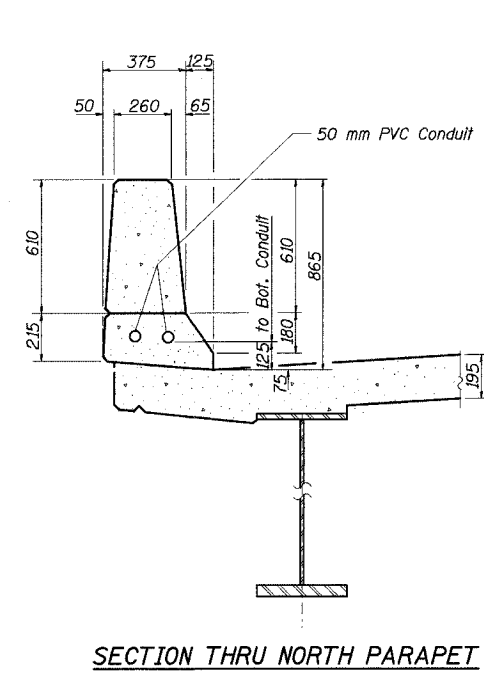
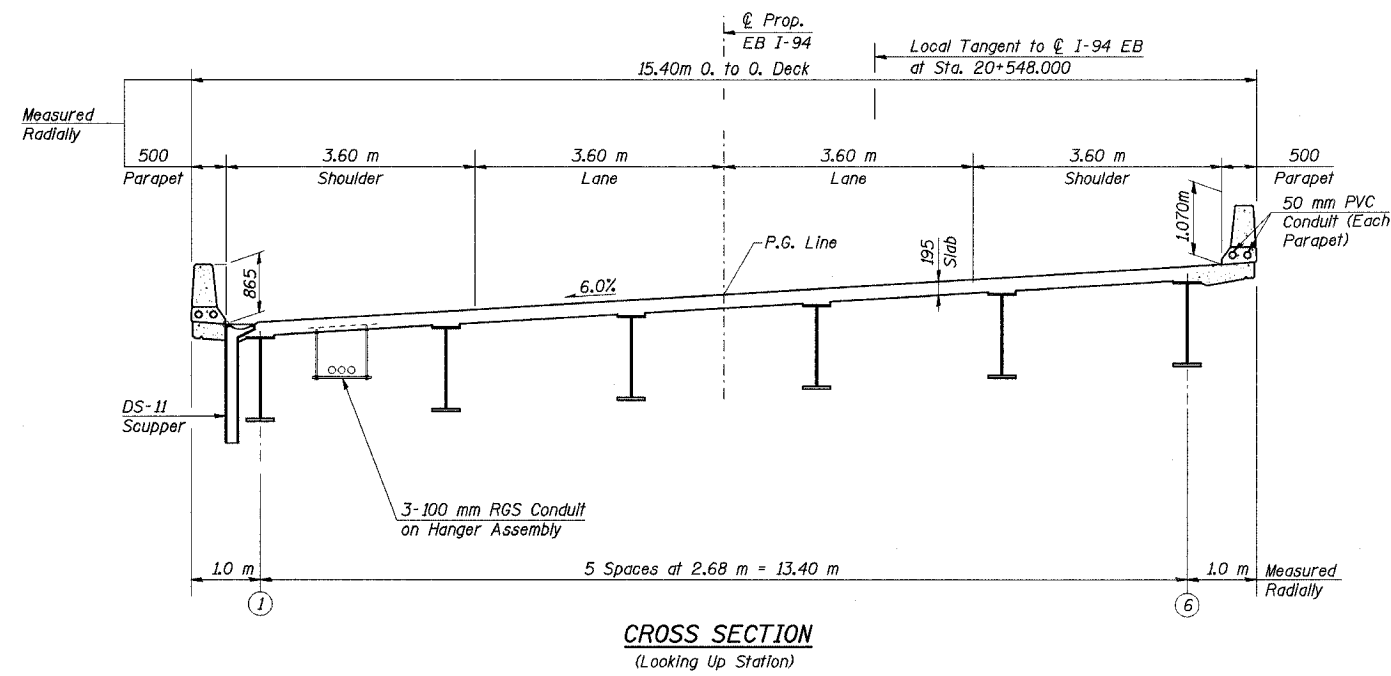

**NOTES:**  
1. All dimensions are in millimeters (mm) except as noted.

DESIGNED	JJK
CHECKED	PCA
DRAWN	LK
CHECKED	PCA

ILLINOIS DEPARTMENT OF TRANSPORTATION  
I-94 EAST BOUND / IL 394 SOUTH BOUND  
**DECK CROSS SECTION & DETAILS**  
EB I-94 OVER THORN CREEK  
F.A.I. 94 SECTION 2004-133F  
COOK COUNTY  
STA. 20+509.000 STRUCTURE NO. 016-2807  
DATE 05/16/05  
SCALE ----

**HNTB**

I:\e1\ca\2004\133F\CADD\1\SN\_2807\cadd\CTR\_29\_2807\ms190814s\_2807.dgn  
20-MAY-2005 14:31