

STATE OF ILLINOIS
DEPARTMENT OF TRANSPORTATION

| | | | | |
|---------------------|----------|---------|--------------|-----------|
| ROUTE NO. | SECTION | COUNTY | TOTAL SHEETS | SHEET NO. |
| FAI 90/94 | * | COOK | 93 | 39 |
| FED. ROAD DIST. NO. | ILLINOIS | PROJECT | | |

* 2005-008F
CONTRACT #62919

Sheet No 8
of 8 Sheets

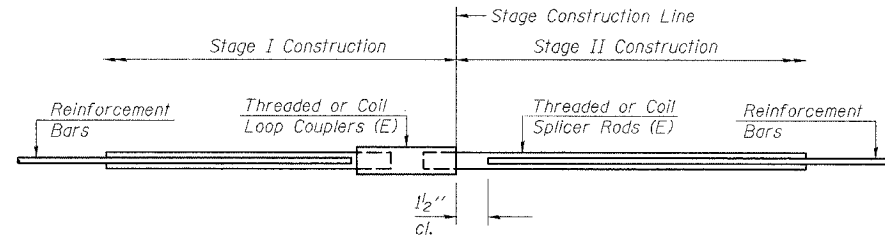

SPLICER DETAIL

| Bar Size | No. Assemblies Required | Location |
|----------|-------------------------|---|
| #5 | 24 | At Stage Construction Line in N.B. Deck |
| | | |
| | | |
| | | |

The diameter of this part is the same as the diameter of the bar spliced.

ROLLED THREAD DOWEL BAR

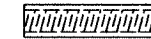

** ONE PIECE

Wire Connector

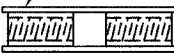

WELDED SECTIONS

BAR SPLICER ASSEMBLY ALTERNATIVES

** Heavy Hex Nuts conforming to ASTM A 563, Grade C, D or DH may be used.

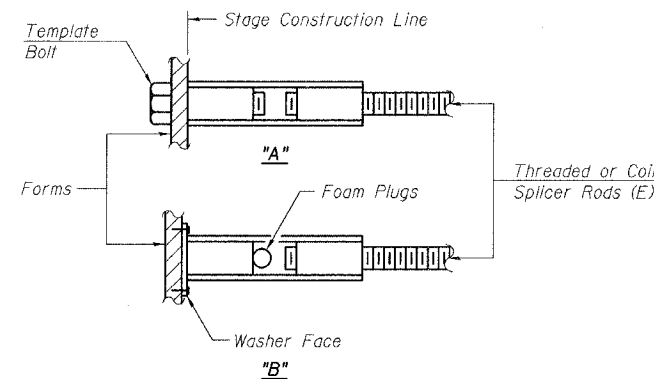

INSTALLATION AND SETTING METHODS

"A" : Set bar splicer assembly by means of a template bolt.
"B" : Set bar splicer assembly by nailing to wood forms or cementing to steel forms.
(E) : Indicates epoxy coating.

NOTES

Bar splicer assemblies shall be of an approved type and shall develop in tension at least 125 percent of the yield strength of the lapped reinforcement bars.
Splicer rods shall be of minimum 60 ksi yield strength, threaded or coiled full length.
All reinforcement bars shall be lapped and tied to the splicer rods or dowel bars.
Bar splicer assemblies shall be epoxy coated according to the requirements for reinforcement bars.
Other systems of similar design may be submitted to the Engineer for approval. Approval shall be based on certified test results from an approved testing laboratory that the proposed bar splicer assembly satisfies the following requirements:

- Minimum Capacity (Tension in kips) = $1.25 \times f_y \times A_t$
- Minimum *Pull-out Strength (Tension in kips) = $1.25 \times f_{s_{allow}} \times A_t$

Where f_y = Yield strength of lapped reinforcement bars in ksi.
 $f_{s_{allow}}$ = Allowable tensile stress in lapped reinforcement bars in ksi (Service Load)
 A_t = Tensile stress area of lapped reinforcement bars.
* = 28 day concrete

| Bar Size to be Spliced | Splicer Rod or Dowel Bar Length | Strength Requirements | |
|------------------------|---------------------------------|------------------------------|---------------------------------------|
| | | Min. Capacity kips - tension | Min. Pull-Out Strength kips - tension |
| #5 | 2'-0" | 23.0 | 9.2 |
| #6 | 2'-7" | 33.1 | 13.3 |
| #7 | 3'-5" | 45.1 | 18.0 |
| #8 | 4'-6" | 58.9 | 23.6 |

Bar splicer assemblies shall be according to Section 508 of the Standard Specifications, except as noted. The furnishing and installation of bar splicer assemblies will be measured and paid for at the contract unit price each for "BAR SPLICERS."

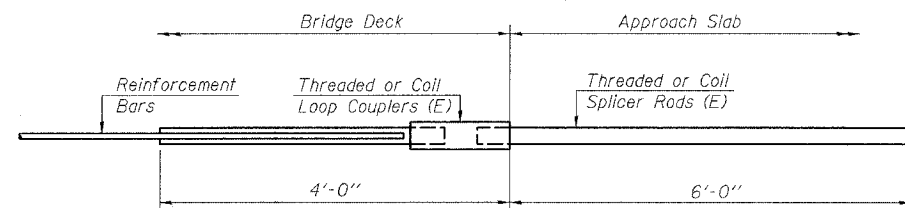

INTEGRAL ABUTMENT
BAR SPLICER ASSEMBLY DETAIL
FOR #5 BAR

| |
|---|
| Min. Capacity = 23.0 kips - tension |
| Min. Pull-out Strength = 9.2 kips - tension |
| No. Required = |

BSD-1 4-30-99

PIER NO. 7

| REVISIONS | | STATE OF ILLINOIS DEPARTMENT OF TRANSPORTATION DIVISION OF HIGHWAYS | | DRAWN BY RLK 5/03 |
|-----------|------|---|--|------------------------|
| NO. | DATE | INITIALS | | CHECKED BY SDS 5/03 |
| 1 | | | | BOOK NUMBER |
| 2 | | | | PROJECT No. |
| 3 | | | | 4222-3 |
| 4 | | | | SHEET No. |
| 5 | | | | |
| 6 | | | | |
| 7 | | | | |
| 8 | | | | |
| 9 | | | | |
| 10 | | | | |

FAI RTE 90/94 DAN RYAN EXPRESSWAY
SN 016-1111 (NORTHBOUND) COOK COUNTY

HOMER L. CHASTAIN & ASSOCIATES
8609 W. BERTH MARSH AVENUE
SUITE 204
CHICAGO, ILLINOIS 60681
312-714-0000
FAX 312-714-0005