

| F.A.I. RTE. | SECTION | COUNTY | TOTAL SHEETS | SHEET NO. |
|---------------------|------------|----------|-------------------|-----------|
| 412 | (50-5B)I-1 | LASALLE | 29 | 22 |
| FED. ROAD DIST. NO. | | ILLINOIS | STATE AID PROJECT | |

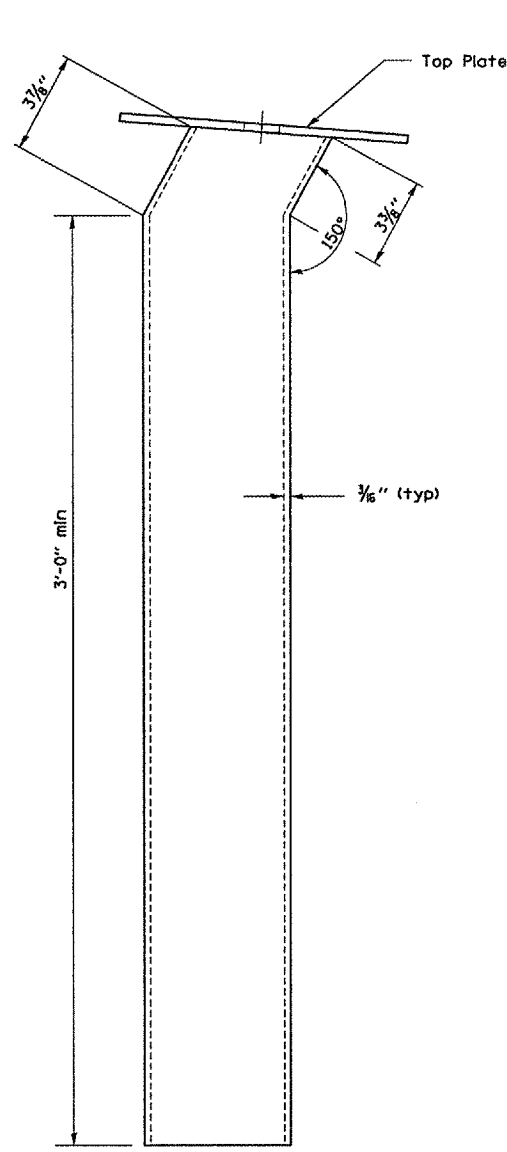

SIDE ELEVATION

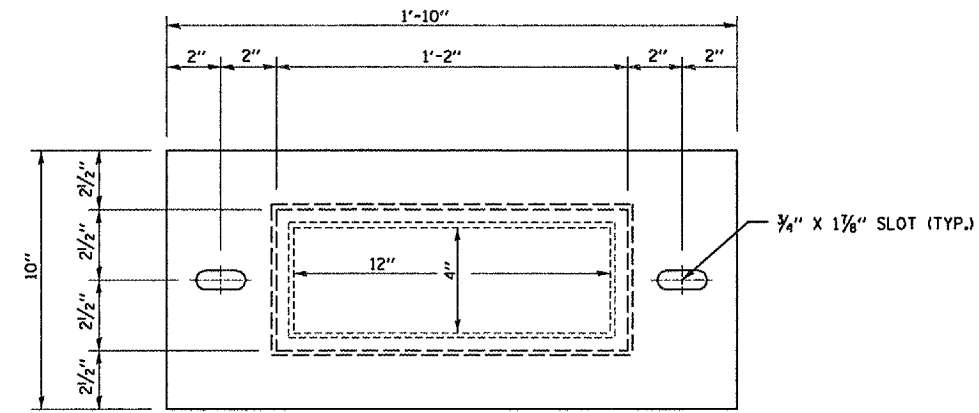

PLAN

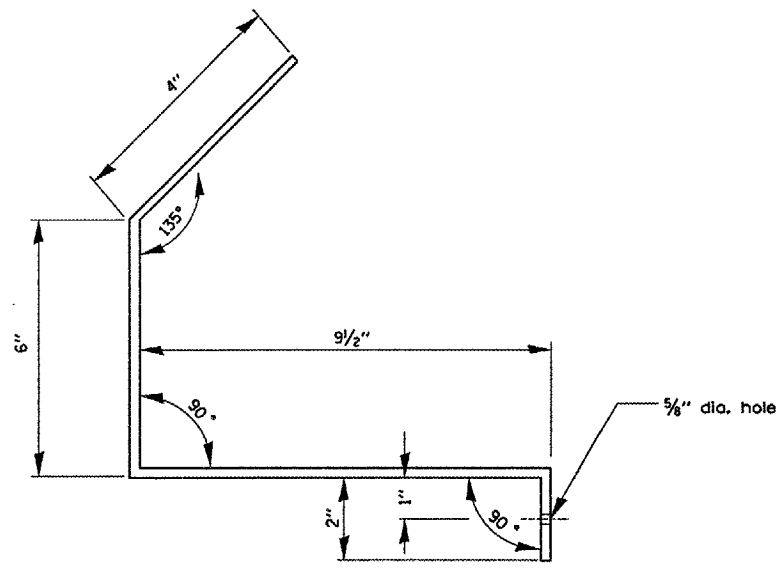

BRACKET

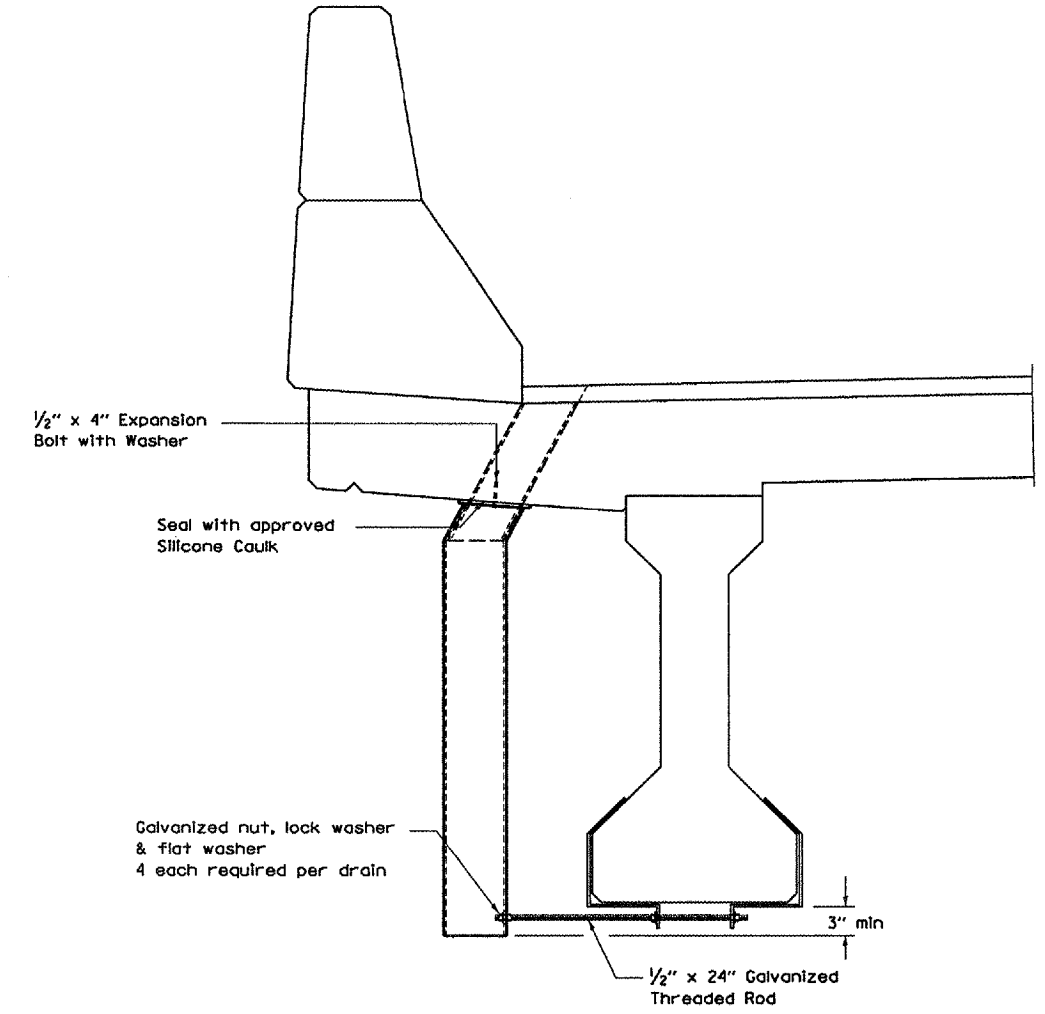

SECTION AT PARAPET

DECK DRAIN EXTENSION

| REVISIONS | |
|-----------|------|
| NAME | DATE |
| | |
| | |
| | |
| | |
| | |
| | |
| | |
| | |
| | |
| | |

ILLINOIS DEPARTMENT OF TRANSPORTATION
DECK DRAIN EXTENSION DETAILS
 F.A.I. 412 SOUTHBOUND
 OVER C. & N.W. RAILROAD
 SECTION (50-5B)I
 STA. 1216 + 43.45
 DATE 04/24/2005
 DRAWN BY RW
 CHECKED BY

MARCH 30, 2005
 C:\PROJECTS\CMA IN06\CM303\DETA ILS.DGN