

F.A.I. RTE.	SECTION	COUNTY	TOTAL SHEETS	SHEET NO.
55	D-6 ITS #1	SANGAMON	56	1

STATE OF ILLINOIS
DEPARTMENT OF TRANSPORTATION
DIVISION OF HIGHWAYS
**PROPOSED
HIGHWAY PLANS**

INDEX OF SHEETS

- 1 COVER SHEET
- 2 LOCATION MAP
- 3 SUMMARY OF QUANTITIES
- 4 GENERAL NOTES AND LEGEND
- 5-6 CAMERA 1 PLAN
- 7 CAMERA 2 PLAN
- 8-10 CAMERA 3 PLAN
- 11 DMS 1 PLAN
- 12 DMS 2 PLAN
- 13-14 CAMERA 2 FIBER
- 15-40 CABLE DIAGRAMS
- 41 OVERHEAD SIGN STRUCTURE PLAN
- 42-51 OVERHEAD SIGN STRUCTURE DETAILS
- 52 INERTIAL BARRIER INSTALLATION DETAILS
- 53 CCTV CAMERA & MOUNTING EQUIPMENT
- 54 DMS MOUNTING AND WIRING DETAILS
- 55 FIBER OPTIC SYSTEM SCHEMATIC
- 56 CAMM CENTER SYSTEM SCHEMATIC

FAI ROUTE 55 (I-55)
SECTION D-6 ITS #1
PROJECT: ITS-0417 (10Z)
SANGAMON COUNTY
C-96-028-05

STANDARDS

- 000001-04
- 701101-01
- 701106-01
- 701400-02
- 701401-03
- ~~701406-04~~
- 701411-03
- 702001-05
- 805001
- 701701-04

BEGIN PROJECT
SECTION: D-6 ITS #1
STA. 171+650 metric
STA. ±202+54 english

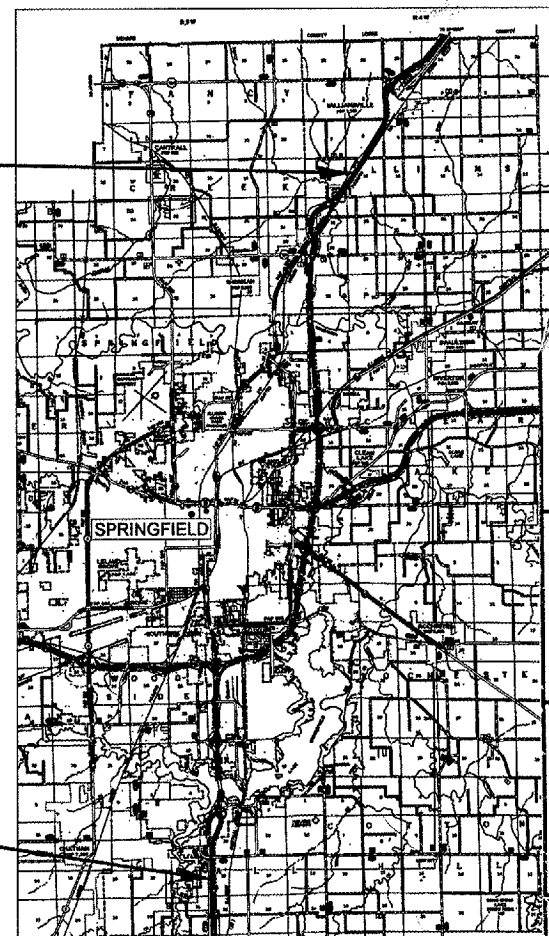

END PROJECT
SECTION: D-6 ITS #1
STATION 234+00 english

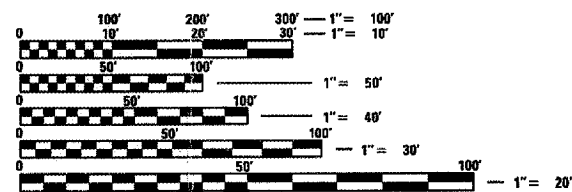

FULL SIZE PLANS HAVE BEEN PREPARED USING STANDARD ENGINEERING SCALES. REDUCED SIZED PLANS WILL NOT CONFORM TO STANDARD SCALES. IN MAKING MEASUREMENTS ON REDUCED PLANS, THE ABOVE SCALES MAY BE USED.

J.U.L.I.E.
JOINT UTILITY LOCATION INFORMATION FOR EXCAVATION
1-800-892-0123

CONTRACT NO. 72A00

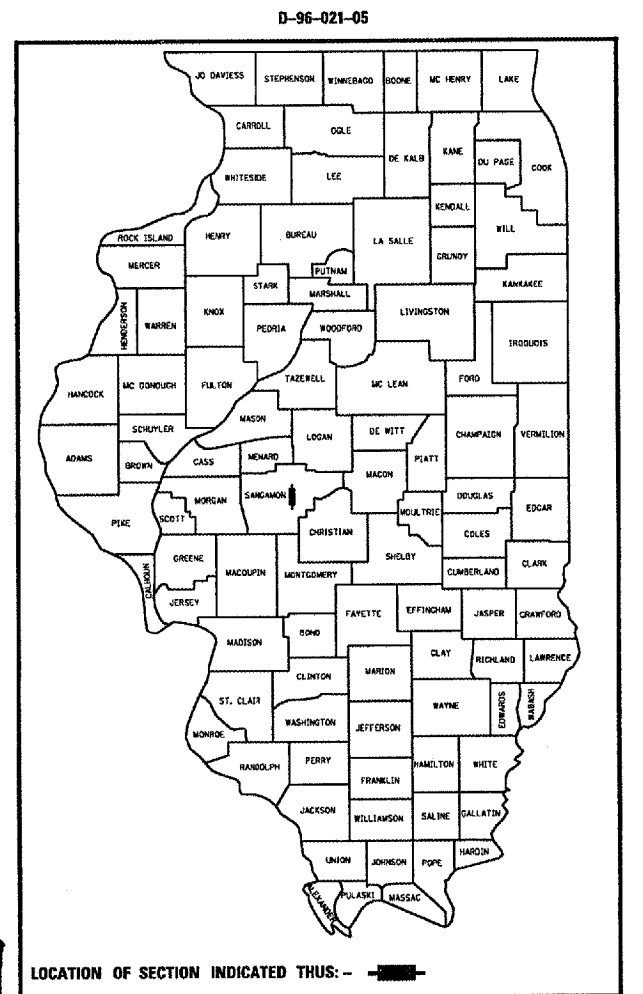

STATE OF ILLINOIS
DEPARTMENT OF TRANSPORTATION
DIVISION OF HIGHWAYS
DISTRICT 6

EXAMINED May 10 2005
Paul J. Hoars
ENGINEER OF OPERATIONS

EXAMINED May 10 2005
W.R. [Signature]
ENGINEER OF PROGRAM IMPLEMENTATION

EXAMINED May 9 2005
William E. [Signature]
ENGINEER OF PROGRAM DEVELOPMENT

STATE OF ILLINOIS
DEPARTMENT OF TRANSPORTATION
DIVISION OF HIGHWAYS

SUBMITTED MAY 10 2005
Quinton M. [Signature]
DEPUTY DIRECTOR OF HIGHWAYS, REGION ENGINEER

May 13, 2005
Mike [Signature]
ENGINEER OF DESIGN AND ENVIRONMENT

May 13, 2005
Victor [Signature]
DIRECTOR OF HIGHWAYS, CHIEF ENGINEER

PRINTED BY THE AUTHORITY
OF THE STATE OF ILLINOIS

KEEP

F.A.I. RTE.	SECTION	COUNTY	TOTAL SHEETS	SHEET NO.
55	D-6 ITS #1	SANGAMON	---	2

FED. ROAD DIST. NO. ILLINOIS FED. AID PROJECT

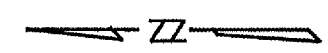
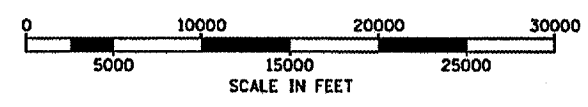
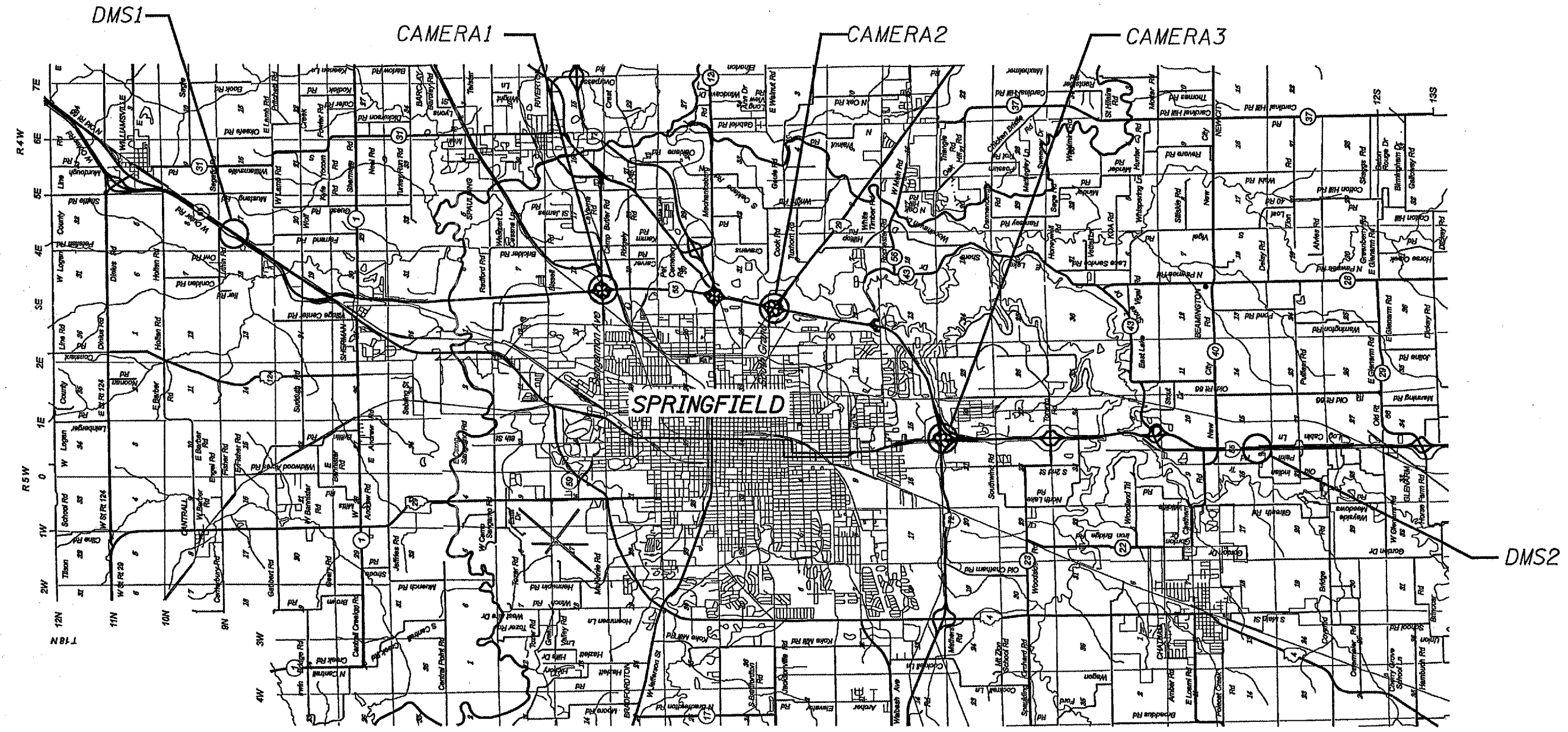

DMS1 - STATION 171+650 metric - 202+54 english
 DMS2 - STATION 234+00 english
 CAMERA1 - STRUCTURE #6C084I055R099.7
 CAMERA2 - STRUCTURE #6C084I055L096.4
 CAMERA3 - STRUCTURE #6C084I072R097.5

REVISIONS	
NAME	DATE

ILLINOIS DEPARTMENT OF TRANSPORTATION
 LOCATION MAP
 F.A.I. 55 (I-55)
 SECTION D-6 ITS #1
 SANGAMON COUNTY

SCALE: VERT. _____
 HORIZ. _____
 DATE _____

DRAWN BY _____
 CHECKED BY _____

SUMMARY OF QUANTITIES

SECTION	COUNTY	TOTAL SHEETS	SHEET NO.
D-6 ITS #1	SANGAMON	-	3
STA. TO STA.		EXISTING CONDITIONS:	

SUMMARY OF QUANTITIES			CONSTRUCTION TYPE CODE Y032-1F
CODE NO	ITEM	UNIT	TOTAL QUANTITIES
67100100	MOBILIZATION	LSUM	1
70100305	TRAFFIC CONTROL AND PROTECTION, STANDARD 701400	LSUM	1
70100420	TRAFFIC CONTROL AND PROTECTION, STANDARD 701411	EACH	3
70100800	TRAFFIC CONTROL AND PROTECTION, STANDARD 701401	LSUM	1
73300300	OVERHEAD SIGN STRUCTURE - SPAN, TYPE III-A (5'-0" X 7'-0")	FOOT	220
73400200	DRILLED SHAFT CONCRETE FOUNDATIONS	CUYD	47.3
80500100	SERVICE INSTALLATION, TYPE A	EACH	5
80801400	WOOD POLE, 25 FT., CLASS 4	EACH	5
81012500	CONDUIT IN TRENCH, 1 1/2" DIA., PVC	FOOT	11358
81012600	CONDUIT IN TRENCH, 2" DIA., PVC	FOOT	3477
81021540	CONDUIT, AUGERED, 1 1/2" DIA., PVC	FOOT	738
81021550	CONDUIT, AUGERED, 2" DIA., PVC	FOOT	1179
81100500	CONDUIT ATTACHED TO STRUCTURE, 1 1/2" DIAMETER, GALVANIZED STEEL	FOOT	270
81100600	CONDUIT ATTACHED TO STRUCTURE, 2" DIAMETER, GALVANIZED STEEL	FOOT	45
81102500	CONDUIT ATTACHED TO STRUCTURE, 1 1/2" DIAMETER, PVC	FOOT	300
81306100	JUNCTION BOX (SPECIAL)	EACH	62
81306200	DRILL EXISTING JUNCTION BOX	EACH	2
81500200	TRENCH BACKFILL FOR ELECTRICAL WORK	FOOT	14835
87100120	FIBER OPTIC CABLE IN CONDUIT, NO. 62.5/125, 8F	FOOT	34412
87301815	ELECTRIC CABLE IN CONDUIT, SERVICE, NO. 6 3/C	FOOT	1255
87900200	DRILL EXISTING HANDHOLE	EACH	4
X0323228	FURNISH AND INSTALL TRUSS DAMPER	EACH	2
X7015000	CHANGEABLE MESSAGE SIGN	CALMO	2
Δ Z0002005	ATTENUATOR BASE	SQYD	51.6
Δ Z0030150	IMPACT ATTENUATOR (NON-REDIRECTIVE), TEST LEVEL 3	EACH	4
X0324963	CLOSED CIRCUIT CAMERA SYSTEM COMPLETE	EACH	3
87301865	ELECTRIC CABLE IN CONDUIT, SERVICE, NO. 8 3/C	FOOT	5073.5
X0324256	FIBER OPTIC SPLICE	EACH	3
X0324964	COMMUNICATION CENTER SUPPORT EQUIPMENT COMPLETE	LSUM	1
73305000	OVERHEAD SIGN STRUCTURE WALKWAY	FOOT	21.5
X0324965	INSTALL TRUSS MOUNTED DYNAMIC MESSAGE SIGN	EACH	2

SUMMARY OF QUANTITIES			CONSTRUCTION TYPE CODE Y032-1F
CODE NO	ITEM	UNIT	TOTAL QUANTITIES
Z0048665	RAILROAD PROTECTIVE LIABILITY INSURANCE	LSUM	1
70102635	TRAFFIC CONTROL AND PROTECTION, STANDARD 701401	LSUM	1

DATE: 11/15/00
DRAWN BY: JMM/SPC
CHECKED BY: JMM/SPC
APP. BY: JMM/SPC
REF. BY: JMM/SPC

Δ SFTY-3N

Rev.

F.A.I. SHEET	SECTION	COUNTY	TOTAL SHEETS	SHEET NO.
55	D-6 ITS #1	SANGAMON		4

STA. TO STA.

EXISTING CONDITIONS:

GENERAL NOTES

- CCTV ARE LOCATION SENSITIVE. PROPOSED EQUIPMENT LOCATIONS ARE APPROXIMATE. TO ENSURE THE OPTIMUM FIELD OF VIEW, ACTUAL LOCATIONS SHALL BE DETERMINED IN THE FIELD BY THE CONTRACTOR, PER THE MANUFACTURER REPRESENTATIVES RECOMMENDATIONS AND THE ENGINEERS APPROVAL. MR. CECIL DOWNING OF BUREAU OF OPERATIONS SHALL BE CONTACTED FOR ACTUAL CAMERA LOCATION VERIFICATION.
- A METAL CONDUIT UTILIZED TO MOUNT CCTV CAMERA ON SIGN TRUSS SHALL BE 4" DIA. (4 1/8" DIA. O. D.) AND SHALL BE SCHEDULE 80 ALUMINUM PIPE.
- PLAN ELEVATIONS - U.S.G.S. MEAN SEA LEVEL DATUM.
- ALL ELEVATIONS SHOWN ON THE PLANS ARE ESTABLISHED FROM U.S.G.S. MEAN SEA LEVEL DATUM.
- U-BOLTS SHALL BE PRODUCED FROM ASTM A276, TYPE 304, 304L, 316, CONDITION A, COLD FINISH, OR AN EQUIVALENT MATERIAL ACCEPTABLE TO THE ENGINEER. ALL NUTS SHALL BE STAINLESS STEEL CONFORMING TO ASTM A194, GRADE 8 (AISI TYPE 304) OR GRADE 8F (AISI TYPE 303). THE NUTS SHALL BE LOCKNUTS WITH NYLON OR STEEL INSERTS AND SEMI FINISHED HEXAGONAL HEADS EQUIVALENT TO THE FINISHED HEX SERIES OF THE AMERICAN NATIONAL STANDARD. ALL WASHERS SHALL BE STAINLESS STEEL CONFORMING TO ASTM 240, TYPE 302 OR 304.
- ALL BOLTS, SCREWS, NUTS AND WASHERS SHALL BE STAINLESS STEEL. ANTI-SEIZE PASTE COMPOUND SHALL BE USED ON ALL MOUNTING HARDWARE FIELD CONNECTIONS. ALL CCTV MOUNTING METHODS AND MOUNTING MATERIAL SHALL BE PRE-APPROVED BY THE ENGINEER.
- UNDERGROUND CABLE MARKING TAPE SHALL BE INSTALLED WITH ALL TRENCH & BACKFILL FOR ELECTRICAL WORK IN ACCORDANCE WITH ARTICLES 815.03 (d) & 1066.05 OF THE STANDARD SPECIFICATIONS.
- A 1/4" DIA. NYLON ROPE SHALL BE INSTALLED IN ALL CONDUIT RUNS. THE COST OF PULL ROPE SHALL BE INCLUDED IN THE PROPOSED ELECTRIC CABLE INSTALLATION IN THAT CONDUIT.
- THE CONTRACTOR SHALL NOT DRILL ANY HOLES IN THE BEAMS, DECK, OR SUBSTRUCTURE OF THE BRIDGE, UNLESS OTHERWISE APPROVED BY THE ENGINEER.
- ALL GROUND RODS SUPPLIED FOR THIS PROJECT SHALL BE 1/2" DIAMETER X 12'-0" LONG.
- THE LOCATION OF EXISTING WATER MAINS, GAS MAINS, SEWERS, ELECTRIC POWER LINES, TELEPHONE LINES AND OTHER UTILITIES AS SHOWN ON THE PLANS ARE BASED ON CAREFUL FIELD INVESTIGATION AND THE BEST INFORMATION AVAILABLE, BUT THEY ARE NOT GUARANTEED. IT SHALL BE THE CONTRACTOR'S RESPONSIBILITY TO ASCERTAIN THEIR EXACT LOCATION FROM THE UTILITY COMPANIES AND BY FIELD INSPECTION.
- ALL UTILITIES SHALL BE LOCATED IN FIELD PRIOR TO ANY ATTEMPT TO CONSTRUCT ANY COMPONENT OF THE VARIOUS CCTV CAMERA SYSTEM. ILLINOIS STATE LAW REQUIRES A 48-HOUR NOTICE BE GIVEN TO UTILITIES BEFORE DIGGING. FIELD MARKING OF FACILITIES MAY BE OBTAINED BY PROVIDING A MINIMUM OF 96-HOURS ADVANCE NOTICE TO THE RESIDENT ENGINEER SO THAT THE UTILITY COMPANIES CAN BE NOTIFIED.
- COORDINATION WITH THE DEPARTMENTS BUREAU OF OPERATIONS IS REQUIRED BEFORE ANY TRENCHING SHALL BE DONE TO LOCATE HIGHWAY LIGHTING/PUMP STATION FACILITIES. PH: (217)558-6523 OR (217)524-9161.
- THE AREAS THAT ARE DISTURBED DUE TO THE DIGGING OR TRENCHING SHALL BE COMPLETED ON A WEEKLY BASIS USING SEEDING, CLASS 2 AND MULCH METHOD 1 AND SHALL CONFORM TO THE REQUIREMENTS OF SECTION 251 OF THE STANDARD SPECIFICATIONS EXCEPT THAT NO EMULSIFIED ASPHALT SHALL BE USED. THE COST SHALL BE INCIDENTAL TO THE CONTRACT.
- THE DEPARTMENT CONTACT PERSON FOR THIS CONTRACT IS CECIL DOWNING, IDOT DISTRICT 6 ITS COORDINATOR, (217)-785-4036. THE CONTRACTOR MUST COORDINATE AND COOPERATE WITH THE DEPARTMENT AND THE INVOLVED PARTIES AS DIRECTED BY THE DEPARTMENT.
- EXISTING CONDUIT AND PULL POINT LOCATIONS TAKEN FROM HISTORICAL DATA. CONTRACTOR SHALL FIELD VERIFY EXISTING CONDUIT SIZES AND LOCATIONS PRIOR TO INSTALLING PROPOSED FIBER OPTIC CABLE WITHIN EXISTING CONDUIT.
- BENDING RADIUS OF FIBER OPTIC CABLE SHALL NOT EXCEED SIX (6) INCHES.
- EXACT FIELD LOCATIONS OF ITS EQUIPMENT SHALL BE AS DIRECTED BY THE ENGINEER. THE CONTRACTOR SHALL TAKE CARE NOT TO INSTALL ITS EQUIPMENT IN DRAINAGE AREAS.
- THE CONTRACTOR SHALL SUBMIT SHOP DRAWINGS, CONSTRUCTION METHODOLOGIES, PRODUCT MANUFACTURER SPECIFICATIONS, OWNERS MANUALS, AND USER MANUALS BEFORE PROCURING AND INSTALLING ANY ITS EQUIPMENT AS PART OF THIS CONTRACT. ALL PROPOSED ITS WORK SHALL BE REVIEWED AND APPROVED BY THE DEPARTMENT.
- THE CONTRACTOR SHALL BE RESPONSIBLE FOR COORDINATING TRAFFIC CONTROL FOR THE INSTALLATION OF ITS RELATED EQUIPMENT WITH OTHER CONTRACTS AND WORK IN THE AREA.

LEGEND

- ALUM ALUMINUM
- EP EDGE OF PAVEMENT
- TW SH TWISTED SHIELDED
- PWR CBL POWER CABLE
- F.O. FIBER OPTIC
- J.B. JUNCTION BOX
- GSC GALVANIZED STEEL CONDUIT
- PVCC POLYVINYL CHLORIDE CONDUIT
- ☐ EXISTING HANDHOLE
- ☐ EXISTING DOUBLE HANDHOLE
- ☐ EXISTING CONTROLLER
- ☐ EXISTING SERVICE INSTALLATION
- EXISTING GALVANIZED STEEL CONDUIT
- ☐ EXISTING JUNCTION BOX
- ☐ EXISTING SIGN TRUSS
- ☐ EXISTING HIGHWAY LIGHTING UNIT
- ☐ EXISTING UNDERGROUND LIGHTING CABLES
- ☐ PROPOSED HANDHOLE
- ☐ PROPOSED DOUBLE HANDHOLE
- ☐ PROPOSED CONTROLLER
- PROPOSED CONDUIT: "T" TRENCH, "P" PUSH, "ATS" ATTACHED TO STRUCTURE, SIZE SPECIFIED
- ☐ PROPOSED SERVICE INSTALLATION
- ☐ PROPOSED CCTV CAMERA
- ☐ PROPOSED JUNCTION BOX, SIZE SPECIFIED
- PROPOSED WOOD POLE, SIZE SPECIFIED
- PROPOSED LIGHT POLE, SIZE SPECIFIED

PLAN	DATE
NO.	
BY	
CHECKED	
DATE	

REVISIONS	
NAME	DATE

ILLINOIS DEPARTMENT OF TRANSPORTATION

GENERAL NOTES & LEGEND

F.A.I. 55 (I-55)
SECTION D-6 ITS #1
SANGAMON COUNTY

DRAWN BY:

NOTE: I-55
REF: 55(1-55)
REF: 55(1-55)

F.A. RTE.	SECTION	COUNTY	TOTAL SHEETS	SHEET NO.
D-6	ITS #1	SANGAMON		5
STA.		TO STA.		
FED. ROAD DIST. NO.		ILLINOIS FED. AID PROJECT		

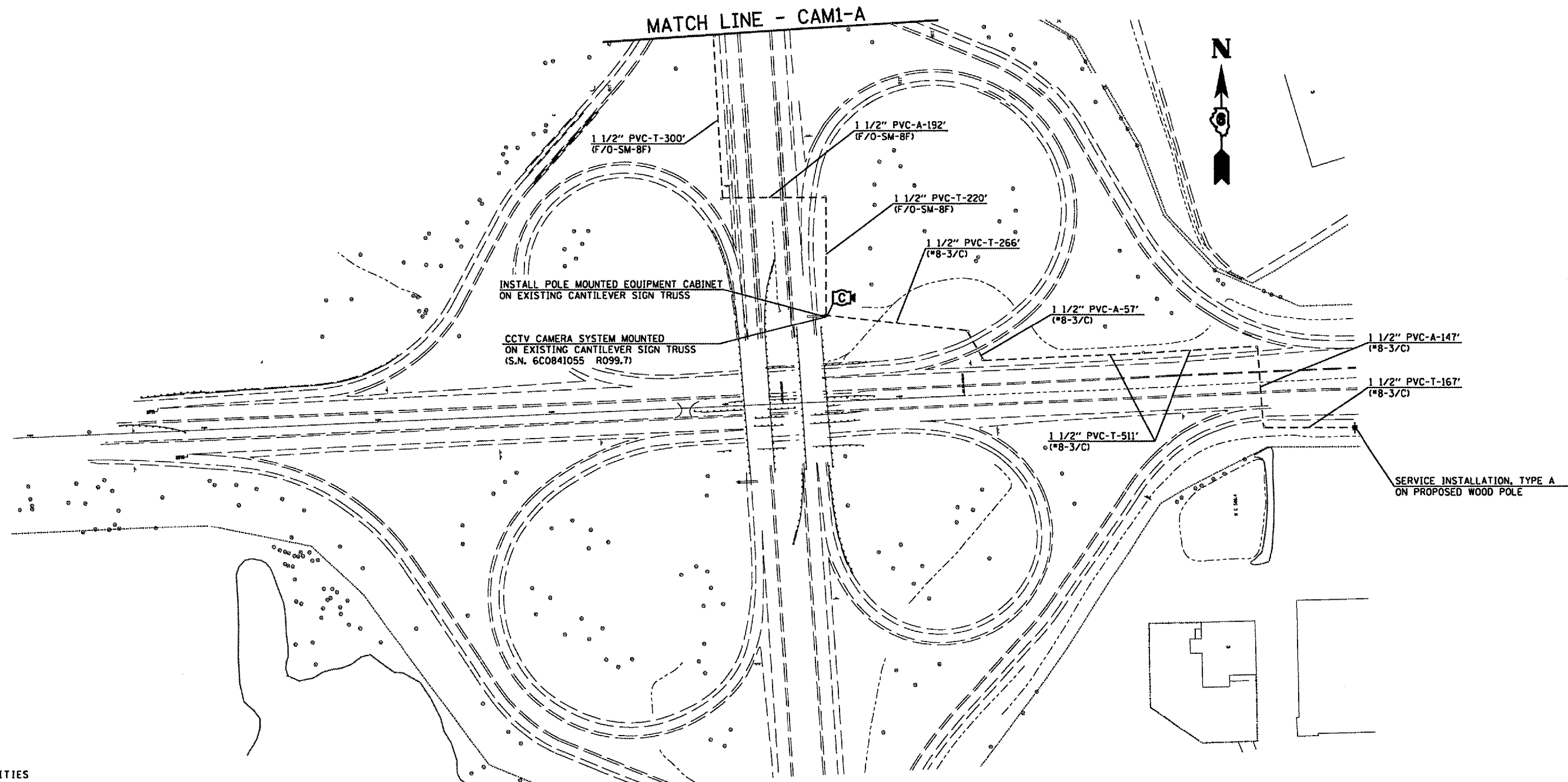

CAMERA 1 QUANTITIES

QUANTITY	UNIT	ITEM
1	EACH	SERVICE INSTALLATION, TYPE A
1	EACH	WOOD POLE, 25 FT., CLASS 4
1464.0	FOOT	CONDUIT IN TRENCH, 1 1/2" DIA., PVC
396.0	FOOT	CONDUIT, AUGERED, 1 1/2" DIA., PVC
15.0	FOOT	CONDUIT ATTACHED TO STRUCTURE, 2" DIA., GALVANIZED STEEL
8	EACH	JUNCTION BOX (SPECIAL)
1464.0	FOOT	TRENCH AND BACKFILL FOR ELECTRICAL WORK
721.5	FOOT	FIBER OPTIC CABLE IN CONDUIT, NO 62.5/125, 8F
1205.5	FOOT	ELECTRIC CABLE IN CONDUIT, SERVICE, NO. 8 3/C

PLOT DATE * DDATES
 FILE NAME * #FILES
 PLOT SCALE * #SCKLS
 USER NAME * #USRN

REVISIONS	
NAME	DATE

ILLINOIS DEPARTMENT OF TRANSPORTATION
CAM 1 PLAN VIEW
 D-6 ITS
 SANGAMON COUNTY
 SCALE: VERT. 1" = 100'
 HORIZ. DATE MAY 2005
 DRAWN BY KDA
 CHECKED BY

F.A. RTE.	SECTION	COUNTY	TOTAL SHEETS	SHEET NO.
	D-6 ITS #1	SANGAMON		6
STA.		TO STA.		
FED. ROAD DIST. NO.	ILLINOIS	FED. AID PROJECT		

CONTRACTOR SHALL CONTACT WITEL COMMUNICATIONS TO ARRANGE FOR THE PROPOSED CONDUIT TO BE CONNECTED TO THE EXISTING VAULT AND FOR THE PROPOSED FIBER OPTIC CABLE TO BE SPLICED TO THE EXISTING FIBER OPTIC BACKBONE. ALL WORK NECESSARY FOR SPLICING THE FIBER OPTIC CABLE WILL BE INCLUDED IN THE FIBER OPTIC SPLICE PAY ITEM. CONTACT JOHN GREEN: (918) 547-1964

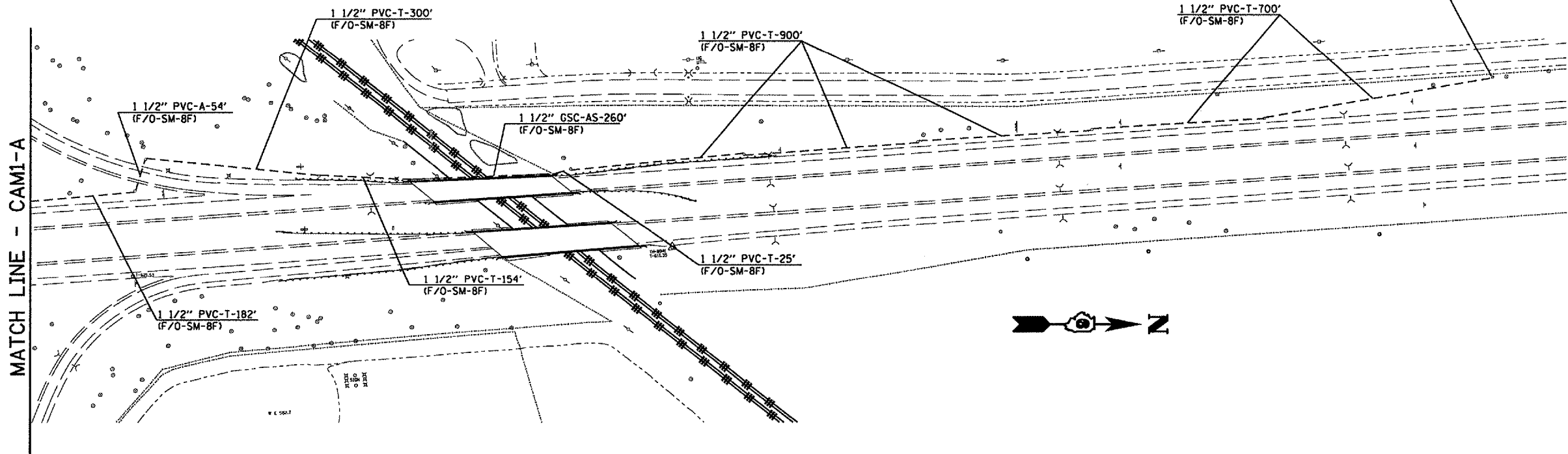

CAMERA 1 QUANTITIES

QUANTITY	UNIT	ITEM
2261.0	FOOT	CONDUIT IN TRENCH, 1 1/2" DIA., PVC
54.0	FOOT	CONDUIT, AUGERED, 1 1/2" DIA., PVC
260.0	FOOT	CONDUIT ATTACHED TO STRUCTURE, 1 1/2" DIA., GALVANIZED STEEL
8	EACH	JUNCTION BOX (SPECIAL)
2261.0	FOOT	TRENCH AND BACKFILL FOR ELECTRICAL WORK
2585.5	FOOT	FIBER OPTIC CABLE IN CONDUIT, NO 62.5/125, 8F
1	EACH	FIBER OPTIC SPLICE

NOTE:
 IN NO WAY SHALL THE VERTICAL OR HORIZONTAL CLEARANCES BE REDUCED BY THE PROPOSED CONDUIT ATTACHMENT.

REVISIONS	
NAME	DATE

ILLINOIS DEPARTMENT OF TRANSPORTATION
CAM 1 PLAN VIEW
 D-6 ITS
 SANGAMON COUNTY

SCALE: VERT. 1" = 100'
 HORIZ. DATE MAY 2005
 DRAWN BY KDA
 CHECKED BY

PLOT DATE * WATER
 FILE NAME * FILEL
 SCALE * INCHES
 USER NAME * USER

Rev.

F.A. RTE.	SECTION	COUNTY	TOTAL SHEETS	SHEET NO.
	D-6 ITS *1	SANGAMON		7
STA.		TO STA.		
FED. ROAD DIST. NO.		ILLINOIS FED. AID PROJECT		

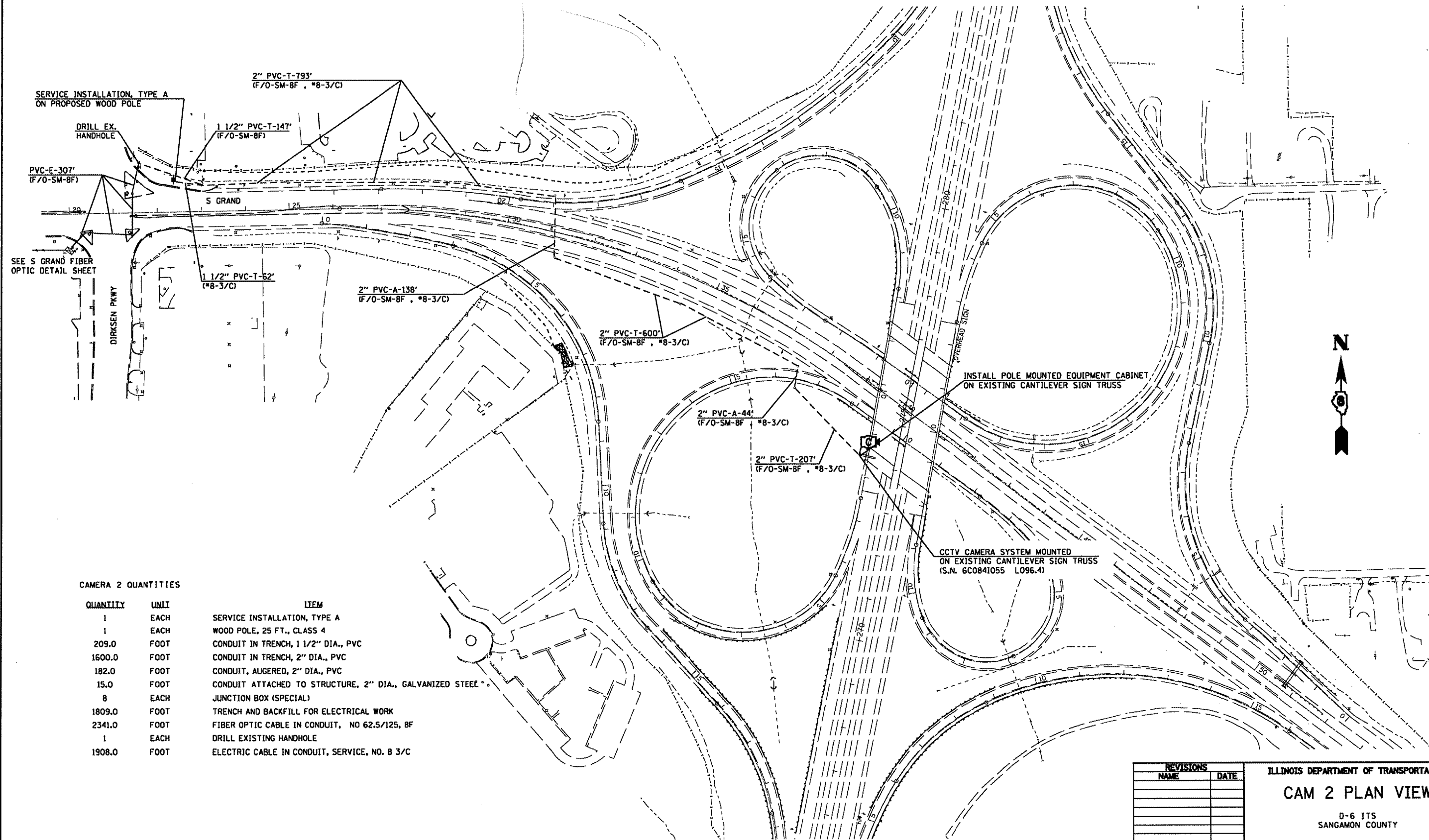

CAMERA 2 QUANTITIES

QUANTITY	UNIT	ITEM
1	EACH	SERVICE INSTALLATION, TYPE A
1	EACH	WOOD POLE, 25 FT., CLASS 4
209.0	FOOT	CONDUIT IN TRENCH, 1 1/2" DIA., PVC
1600.0	FOOT	CONDUIT IN TRENCH, 2" DIA., PVC
182.0	FOOT	CONDUIT, AUGERED, 2" DIA., PVC
15.0	FOOT	CONDUIT ATTACHED TO STRUCTURE, 2" DIA., GALVANIZED STEEL *
8	EACH	JUNCTION BOX (SPECIAL)
1809.0	FOOT	TRENCH AND BACKFILL FOR ELECTRICAL WORK
2341.0	FOOT	FIBER OPTIC CABLE IN CONDUIT, NO 62.5/125, BF
1	EACH	DRILL EXISTING HANDHOLE
1908.0	FOOT	ELECTRIC CABLE IN CONDUIT, SERVICE, NO. 8 3/C

REVISIONS	
NAME	DATE

ILLINOIS DEPARTMENT OF TRANSPORTATION
CAM 2 PLAN VIEW
 D-6 ITS
 SANGAMON COUNTY

SCALE: VERT. 1" = 100'
 HORIZ. 1" = 100'
 DATE: _____ DRAWN BY: KDA
 CHECKED BY: _____

PLOT DATE: _____
 FILE NAME: _____
 PLOT SCALE: _____
 USER NAME: _____

F.A. RTE.	SECTION	COUNTY	TOTAL SHEETS	SHEET NO.
D-6	ITS #1	SANGAMON	8	8
STA.		TO STA.		
FED. ROAD DIST. NO.		ILLINOIS FED. AID PROJECT		

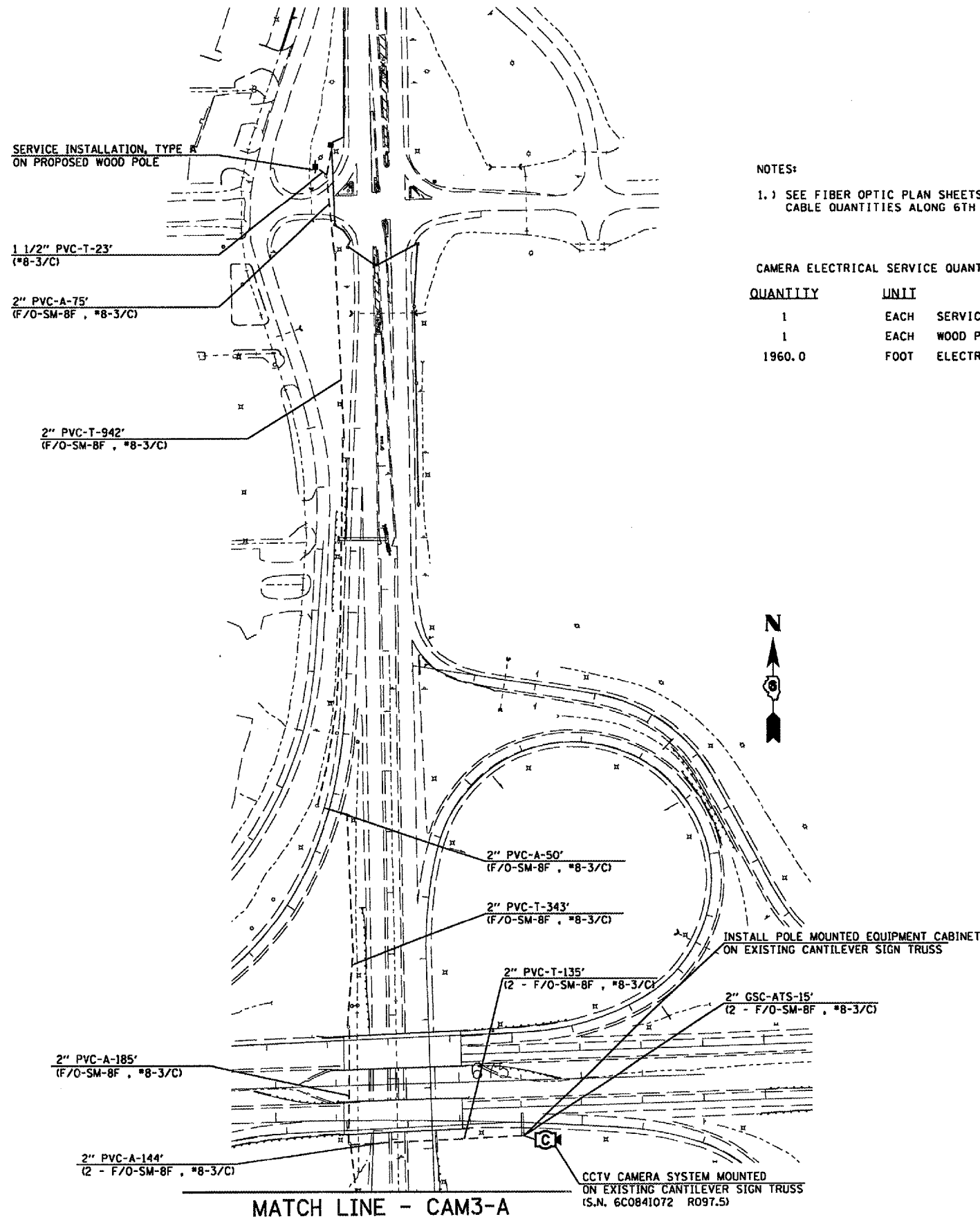

NOTES:

1.) SEE FIBER OPTIC PLAN SHEETS FOR CONDUIT AND FIBER OPTIC CABLE QUANTITIES ALONG 6TH ST.

CAMERA ELECTRICAL SERVICE QUANTITIES

QUANTITY	UNIT	ITEM
1	EACH	SERVICE INSTALLATION, TYPE A
1	EACH	WOOD POLE, 25 FT., CLASS 4
1960.0	FOOT	ELECTRIC CABLE IN CONDUIT, SERVICE, NO. 8 3/C



PLOT DATE
FILE NAME
PLOT SCALE
USER NAME

REVISIONS	
NAME	DATE

ILLINOIS DEPARTMENT OF TRANSPORTATION
CAM 3 PLAN VIEW
D-6 ITS
SANGAMON COUNTY
SCALE: VERT. 1" = 100'
HORIZ.
DATE MAY 2005
DRAWN BY KDA
CHECKED BY

MATCH LINE - CAM3-A

CCTV CAMERA SYSTEM MOUNTED ON EXISTING CANTILEVER SIGN TRUSS (S.N. 6C0841072 R097.5)

F.A. RTE.	SECTION	COUNTY	TOTAL SHEETS	SHEET NO.
	D-6 ITS #1	SANGAMON		9
STA.		TO STA.		
FED. ROAD DIST. NO.		ILLINOIS FED. AID PROJECT		

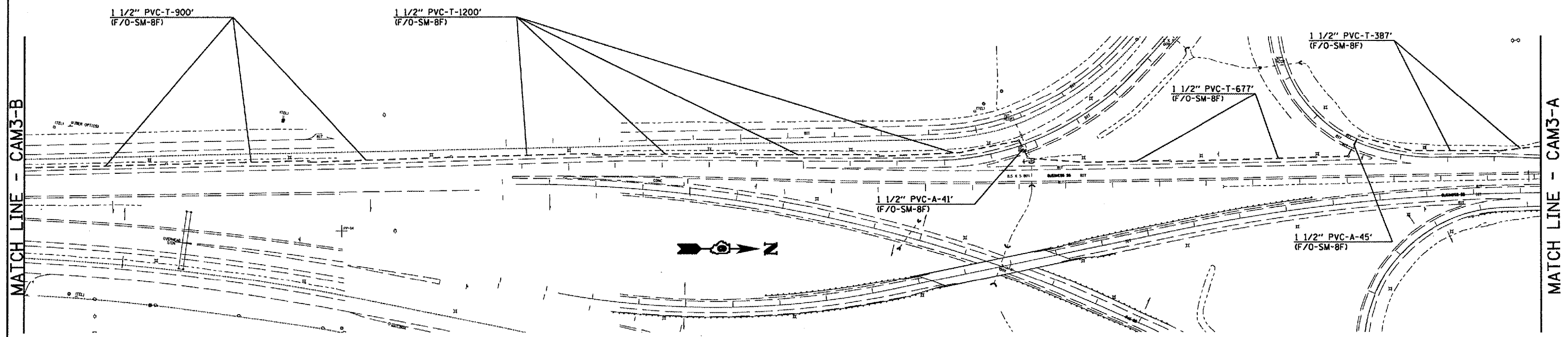

MATCH LINE - CAM3-B

MATCH LINE - CAM3-A



CAMERA 3 FIBER OPTIC QUANTITIES

QUANTITY	UNIT	ITEM
3164.0	FOOT	CONDUIT IN TRENCH, 1 1/2" DIA., PVC
86.0	FOOT	CONDUIT, AUGERED, 1 1/2" DIA., PVC
12	EACH	JUNCTION BOX (SPECIAL)
3164.0	FOOT	TRENCH AND BACKFILL FOR ELECTRICAL WORK
3268.0	FOOT	FIBER OPTIC CABLE IN CONDUIT, NO 62.5/125, 8F

REVISIONS	
NAME	DATE

ILLINOIS DEPARTMENT OF TRANSPORTATION
CAM 3 PLAN VIEW
 D-6 ITS
 SANGAMON COUNTY
 SCALE: VERT. 1" = 100'
 HORIZ. DATE MAY 2005
 DRAWN BY KDA
 CHECKED BY

PLOT DATE = 05/05/05
 FILE NAME = 051015.DWG
 USER NAME = KDA

F.A. RTE.	SECTION	COUNTY	TOTAL SHEETS	SHEET NO.
	D-6 ITS #1	SANGAMON		10
STA.		TO STA.		
FED. ROAD DIST. NO.	ILLINOIS	FED. AID PROJECT		

MATCH LINE - CAM3-B

CAMERA 3 FIBER OPTIC QUANTITIES

QUANTITY	UNIT	ITEM
2797.0	FOOT	CONDUIT IN TRENCH, 1 1/2" DIA., PVC
78.0	FOOT	CONDUIT, AUGERED, 1 1/2" DIA., PVC
10	EACH	JUNCTION BOX (SPECIAL)
2797.0	FOOT	TRENCH AND BACKFILL FOR ELECTRICAL WORK
2890.0	FOOT	FIBER OPTIC CABLE IN CONDUIT, NO 62.5/125, 8F
1	EACH	FIBER OPTIC SPLICE

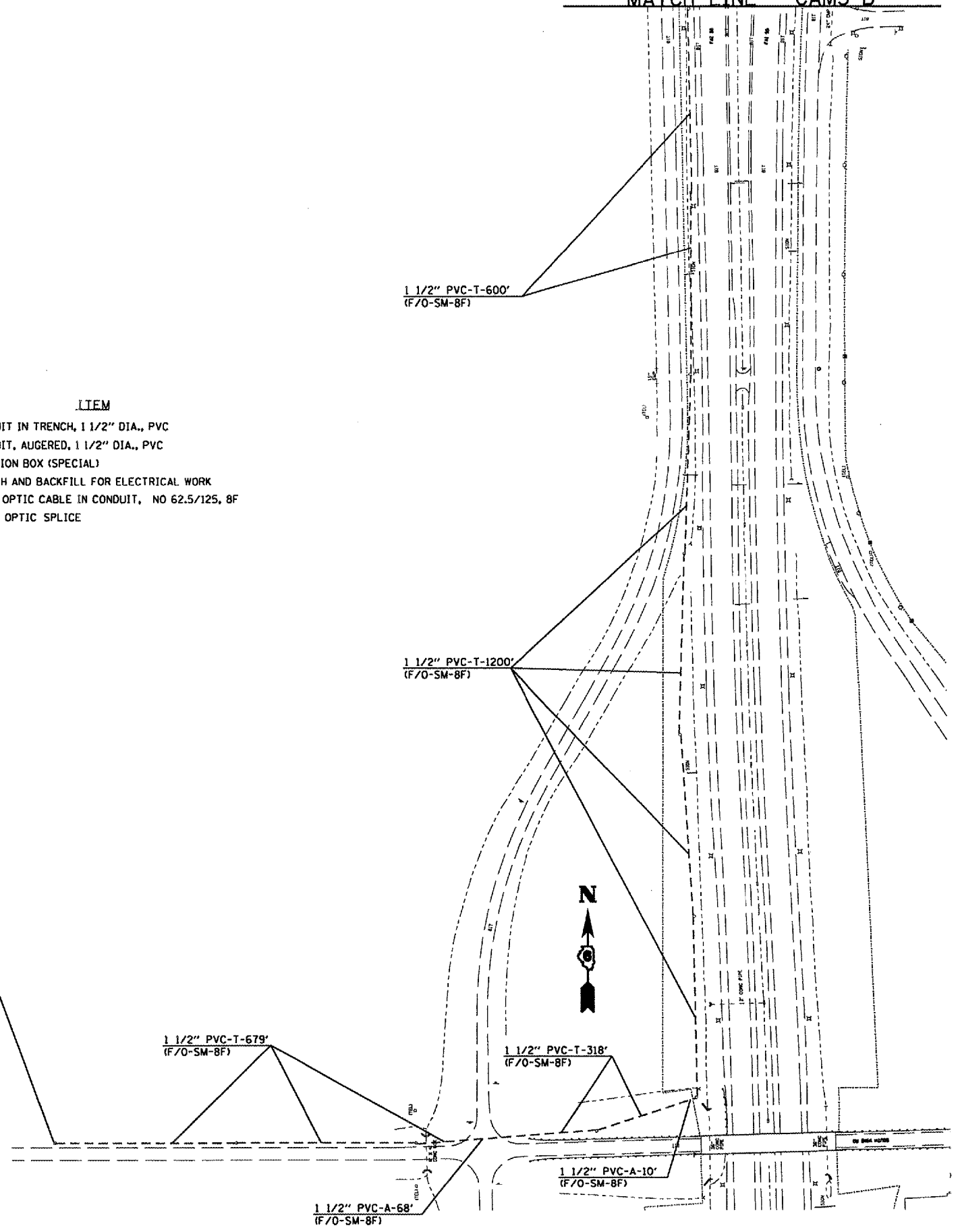

CONTRACTOR SHALL CONTACT WILTEL COMMUNICATIONS TO ARRANGE FOR THE PROPOSED CONDUIT TO BE CONNECTED TO THE EXISTING VAULT AND FOR THE PROPOSED FIBER OPTIC CABLE TO BE SPLICED TO THE EXISTING FIBER OPTIC BACKBONE. ALL WORK NECESSARY FOR SPLICING THE FIBER OPTIC CABLE WILL BE INCLUDED IN THE FIBER OPTIC SPLICE PAY ITEM.
CONTACT JOHN GREEN: (918) 547-1964



REVISIONS	
NAME	DATE

ILLINOIS DEPARTMENT OF TRANSPORTATION
CAM 3 PLAN VIEW
 D-6 ITS
 SANGAMON COUNTY
 SCALE: VERT. 1" = 100'
 HORIZ. DATE MAY 2005
 DRAWN BY KDA
 CHECKED BY

PLOT DATE * DATE
 FILE NAME * FILE#
 USER NAME * USER#

F.A. RTE.	SECTION	COUNTY	TOTAL SHEETS	SHEET NO.
	D-6 ITS #1	SANGAMON		11
STA.		TO STA.		
FED. ROAD DIST. NO.	ILLINOIS	FED. AID PROJECT		

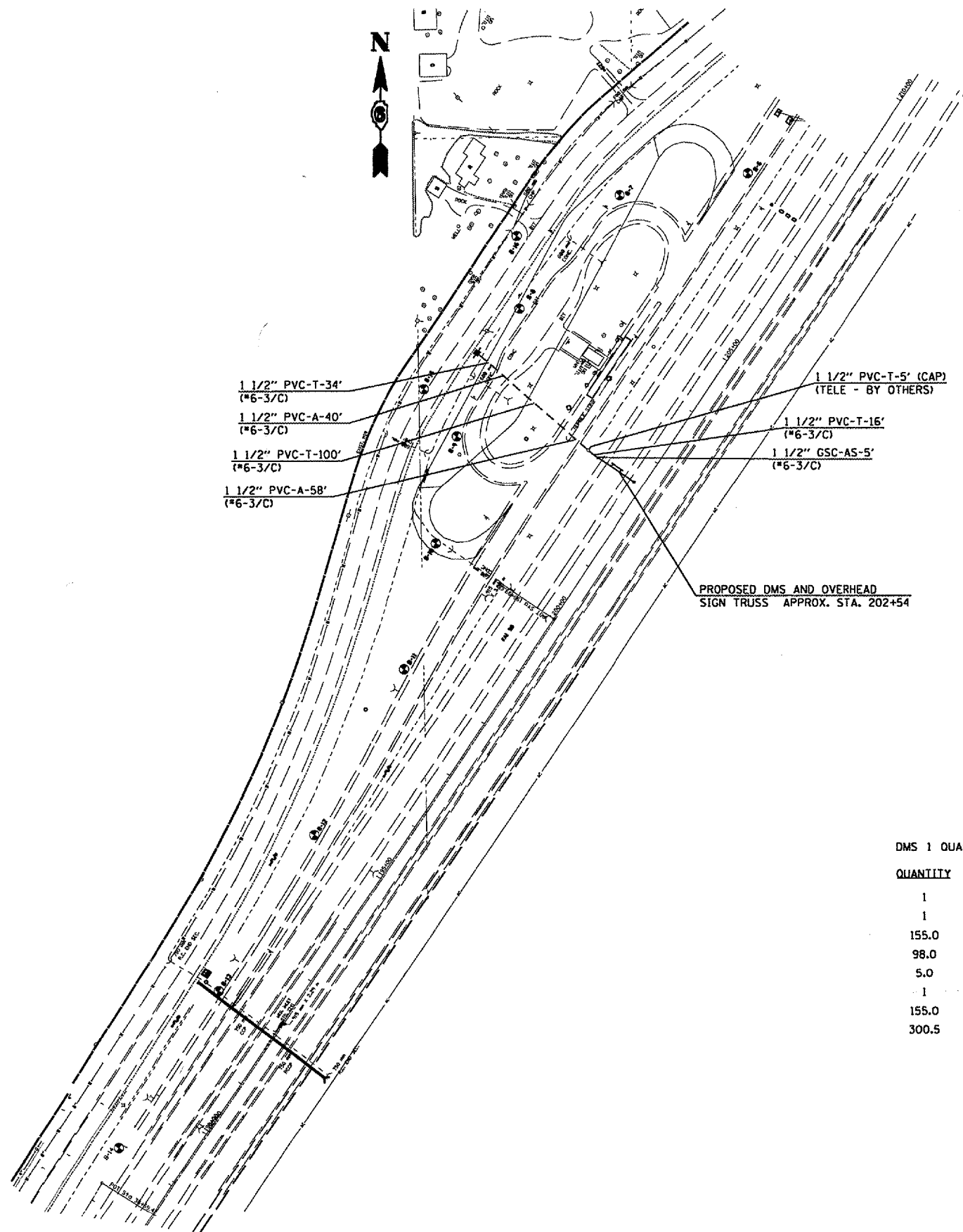

- 1 1/2" PVC-T-34' (*6-3/C)
- 1 1/2" PVC-A-40' (*6-3/C)
- 1 1/2" PVC-T-100' (*6-3/C)
- 1 1/2" PVC-A-58' (*6-3/C)
- 1 1/2" PVC-T-5' (CAP) (TELE - BY OTHERS)
- 1 1/2" PVC-T-16' (*6-3/C)
- 1 1/2" GSC-AS-5' (*6-3/C)

PROPOSED DMS AND OVERHEAD SIGN TRUSS APPROX. STA. 202+54

DMS 1 QUANTITIES

QUANTITY	UNIT
1	EACH
1	EACH
155.0	FOOT
98.0	FOOT
5.0	FOOT
1	EACH
155.0	FOOT
300.5	FOOT

ITEM
SERVICE INSTALLATION, TYPE A
WOOD POLE, 25 FT., CLASS 4
CONDUIT IN TRENCH, 1 1/2" DIA., PVC
CONDUIT, AUGERED, 1 1/2" DIA., PVC
CONDUIT ATTACHED TO STRUCTURE, 1 1/2" DIA., GALVANIZED STEEL
JUNCTION BOX (SPECIAL)
TRENCH AND BACKFILL FOR ELECTRICAL WORK
ELECTRIC CABLE IN CONDUIT, SERVICE, NO. 6 3/C

PLOT DATE: * DATE *
 FILE NAME: * FILE *
 PLOT SCALE: * SCALE *
 USER NAME: * USER *

REVISIONS	
NAME	DATE

ILLINOIS DEPARTMENT OF TRANSPORTATION
DMS 1 PLAN VIEW
 D-6 ITS
 SANGAMON COUNTY
 SCALE: VERT. 1" = 100'
 HORIZ. 1" = 100'
 DATE: MAY 2005
 DRAWN BY: KDA
 CHECKED BY:

F.A. RTE.	SECTION	COUNTY	TOTAL SHEETS	SHEET NO.
	D-6 ITS #1	SANGAMON		12
STA.		TO STA.		
FED. ROAD DIST. NO.	ILLINOIS	FED. AID PROJECT		

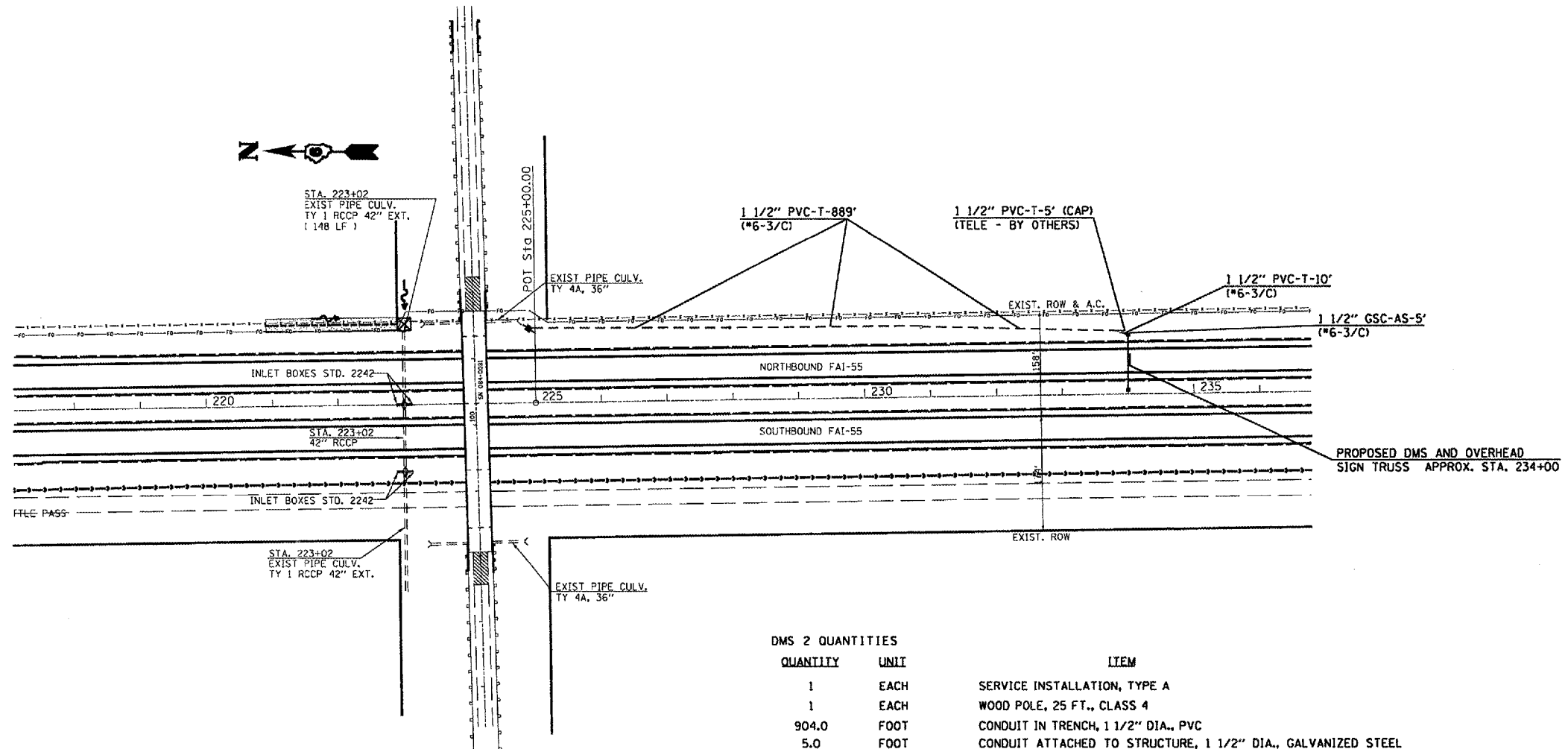

DMS 2 QUANTITIES

QUANTITY	UNIT	ITEM
1	EACH	SERVICE INSTALLATION, TYPE A
1	EACH	WOOD POLE, 25 FT., CLASS 4
904.0	FOOT	CONDUIT IN TRENCH, 1 1/2" DIA., PVC
5.0	FOOT	CONDUIT ATTACHED TO STRUCTURE, 1 1/2" DIA., GALVANIZED STEEL
3	EACH	JUNCTION BOX (SPECIAL)
904.0	FOOT	TRENCH AND BACKFILL FOR ELECTRICAL WORK
954.5	FOOT	ELECTRIC CABLE IN CONDUIT, SERVICE, NO. 6 3/C



PLOT DATE * DATE
 FILE NAME * FILEL
 PLOT SCALE * SCALE
 USER NAME * USER

REVISIONS	
NAME	DATE

ILLINOIS DEPARTMENT OF TRANSPORTATION
DMS 2 PLAN VIEW
 D-6 ITS
 SANGAMON COUNTY
 SCALE: VERT. 1" = 100'
 HORIZ. DATE MAY 2005
 DRAWN BY KDA
 CHECKED BY

F.A. RTE.	SECTION	COUNTY	TOTAL SHEETS	SHEET NO.
D-6 ITS #1	SANGAMON		13	
STA.		TO STA.		
FED. ROAD DIST. NO.	ILLINOIS	FED. AID PROJECT		

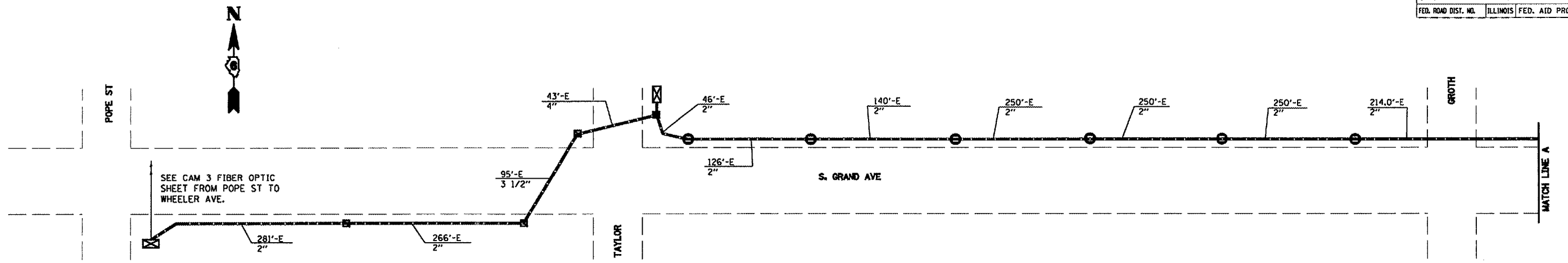

SEE CAM 3 FIBER OPTIC SHEET FROM POPE ST TO WHEELER AVE.

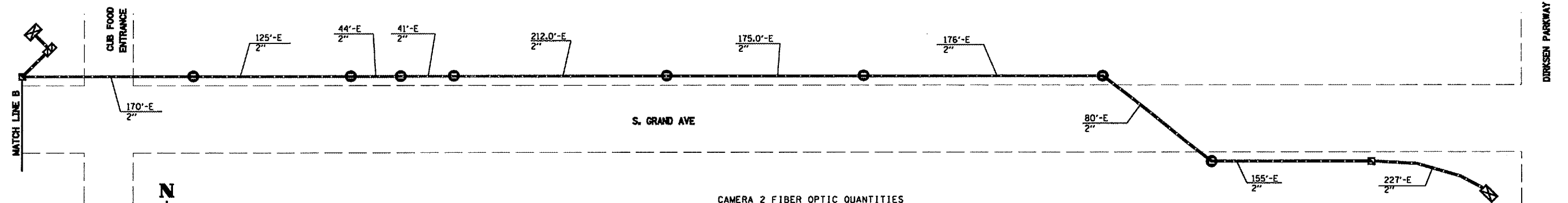
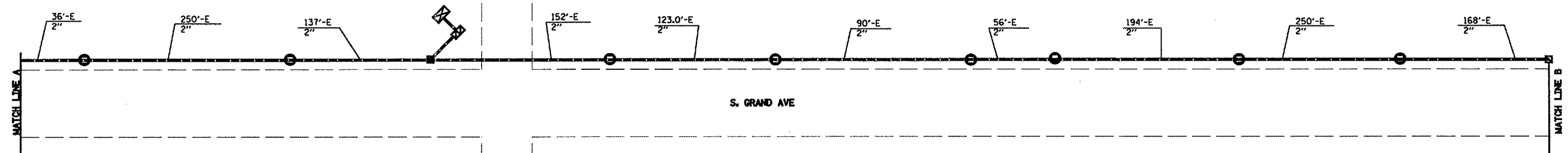

CAMERA 2 FIBER OPTIC QUANTITIES

QUANTITY	UNIT	ITEM
4903.5	FOOT	FIBER OPTIC CABLE IN CONDUIT, NO 62.5/125, 8F

REVISIONS	
NAME	DATE

ILLINOIS DEPARTMENT OF TRANSPORTATION
CAM 2 FIBER OPTIC
 D-6 ITS
 SANGAMON COUNTY
 SCALE: VERT. NOT TO SCALE
 HORIZ. DATE
 DRAWN BY KDA
 CHECKED BY

PLOT DATE
 FILE NAME
 PLOT SCALE
 USER NAME

F.A. RTE.	SECTION	COUNTY	TOTAL SHEETS	SHEET NO.
	D-6 ITS #1	SANGAMON		14
STA.		TO STA.		
FED. ROAD DIST. NO.	ILLINOIS	FED. AID PROJECT		

CONTRACTOR SHALL CONTACT WITTEL COMMUNICATIONS TO ARRANGE FOR THE PROPOSED CONDUIT TO BE CONNECTED TO THE EXISTING VAULT AND FOR THE PROPOSED FIBER OPTIC CABLE TO BE SPLICED TO THE EXISTING FIBER OPTIC BACKBONE. ALL WORK NECESSARY FOR SPLICING THE FIBER OPTIC CABLE WILL BE INCLUDED IN THE FIBER OPTIC SPLICE PAY ITEM. CONTACT JOHN GREEN; (918) 547-1964

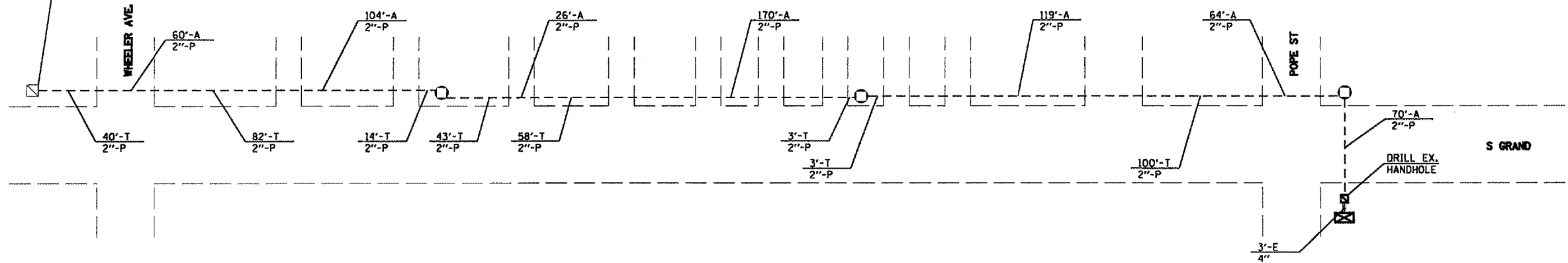

CAMERA 2 FIBER OPTIC QUANTITIES

QUANTITY	UNIT	ITEM
413.0	FOOT	CONDUIT IN TRENCH, 2" DIA., PVC
543.0	FOOT	CONDUIT, AUGERED, 2" DIA., PVC
3	EACH	JUNCTION BOX (SPECIAL)
413.0	FOOT	TRENCH AND BACKFILL FOR ELECTRICAL WORK
973.0	FOOT	FIBER OPTIC CABLE IN CONDUIT, NO 62.5/125, 8F
1	EACH	DRILL EXISTING HANDHOLE
1	EACH	FIBER OPTIC SPLICE



REVISIONS	
NAME	DATE

ILLINOIS DEPARTMENT OF TRANSPORTATION
CAM 2 FIBER OPTIC
 D-6 ITS
 SANGAMON COUNTY

SCALE: VERT. NOT TO SCALE
 HORIZ. DATE
 DRAWN BY KDA
 CHECKED BY

PLOT DATE * DATE *
 FILE NAME * FILE *
 PLOT SCALE * SCALE *
 USER NAME * USER

F.A. RTE.	SECTION	COUNTY	TOTAL SHEETS	SHEET NO.
	D-6 ITS #1	SANGAMON		15
STA.		TO STA.		
FED. ROAD DIST. NO.	ILLINOIS	FED. AID PROJECT		

FIBER OPTIC QUANTITIES

QUANTITY	UNIT	ITEM
77.0	FOOT	CONDUIT IN TRENCH, 1 1/2" DIA., PVC
152.0	FOOT	CONDUIT IN TRENCH, 2" DIA., PVC
329.0	FOOT	CONDUIT, AUGERED, 2" DIA., PVC
15.0	FOOT	CONDUIT ATTACHED TO STRUCTURE, 2" DIA., GALVANIZED STEEL
2	EACH	JUNCTION BOX (SPECIAL)
229.0	FOOT	TRENCH AND BACKFILL FOR ELECTRICAL WORK
850.0	FOOT	FIBER OPTIC CABLE IN CONDUIT, NO 62.5/125, 8F

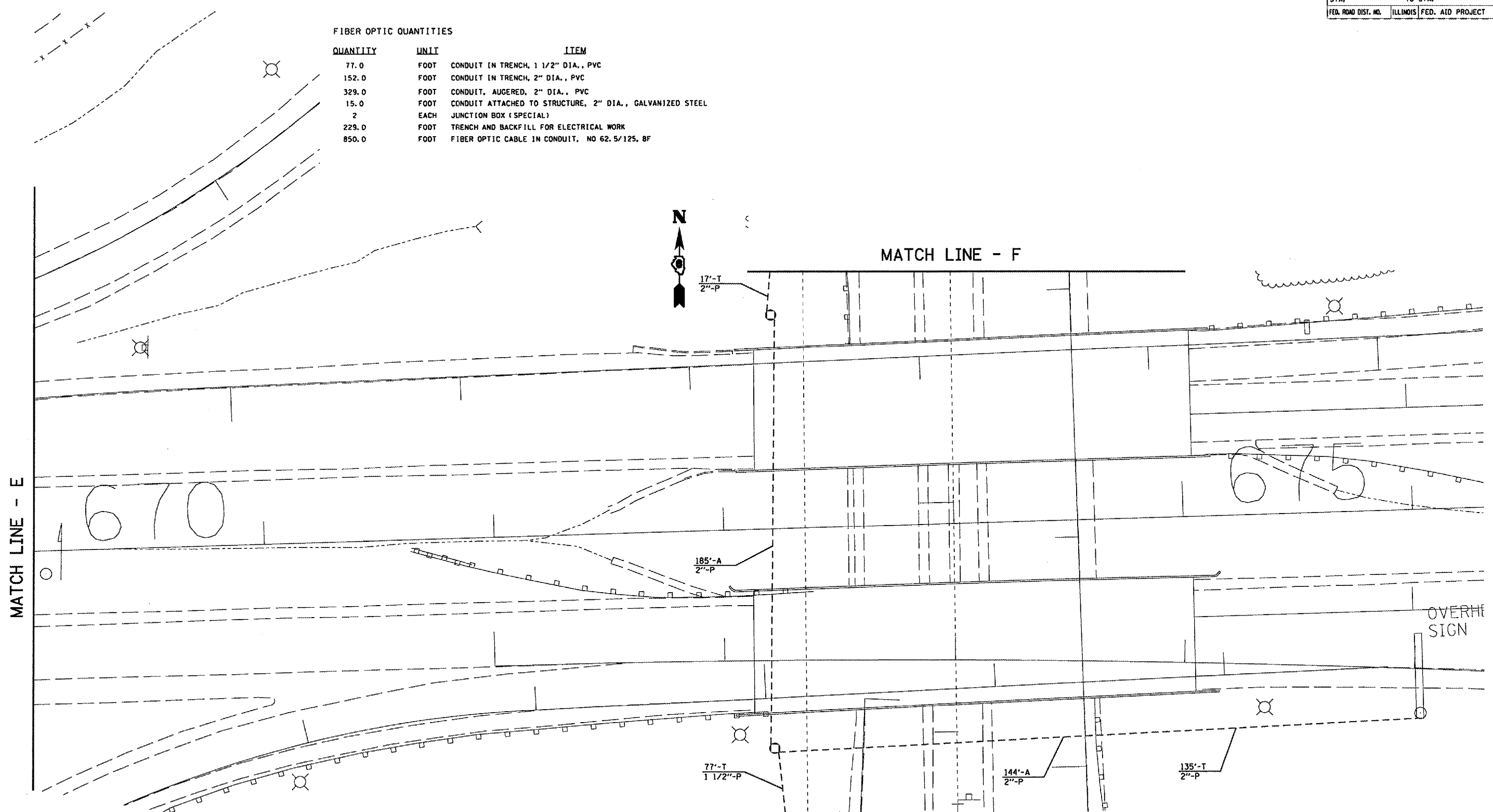

PLOT DATE * DATE
 FILE NAME * FILENAME
 PLOT SCALE * SCALE
 USER NAME * USERNAME

REVISIONS	
NAME	DATE

ILLINOIS DEPARTMENT OF TRANSPORTATION
PROPOSED FIBER OPTIC
 STEVENSON DR
 D-6 ITS
 SANGAMON COUNTY
 SCALE: VERT. 1" = 20'
 HORIZ. 1" = 20'
 DATE MAY 2005
 DRAWN BY KOA
 CHECKED BY

F.A. RTE.	SECTION	COUNTY	TOTAL SHEETS	SHEET NO.
	D-6 ITS #1	SANGAMON		16
STA.	TO STA.			
FED. ROAD DIST. NO.	ILLINOIS	FED. AID PROJECT		

FIBER OPTIC QUANTITIES

QUANTITY	UNIT	ITEM
485.0	FOOT	CONDUIT IN TRENCH, 2" DIA., PVC
50.0	FOOT	CONDUIT, AUGERED, 2" DIA., PVC
2	EACH	JUNCTION BOX (SPECIAL)
485.0	FOOT	TRENCH AND BACKFILL FOR ELECTRICAL WORK
538.0	FOOT	FIBER OPTIC CABLE IN CONDUIT, NO 62.5/125, 8F

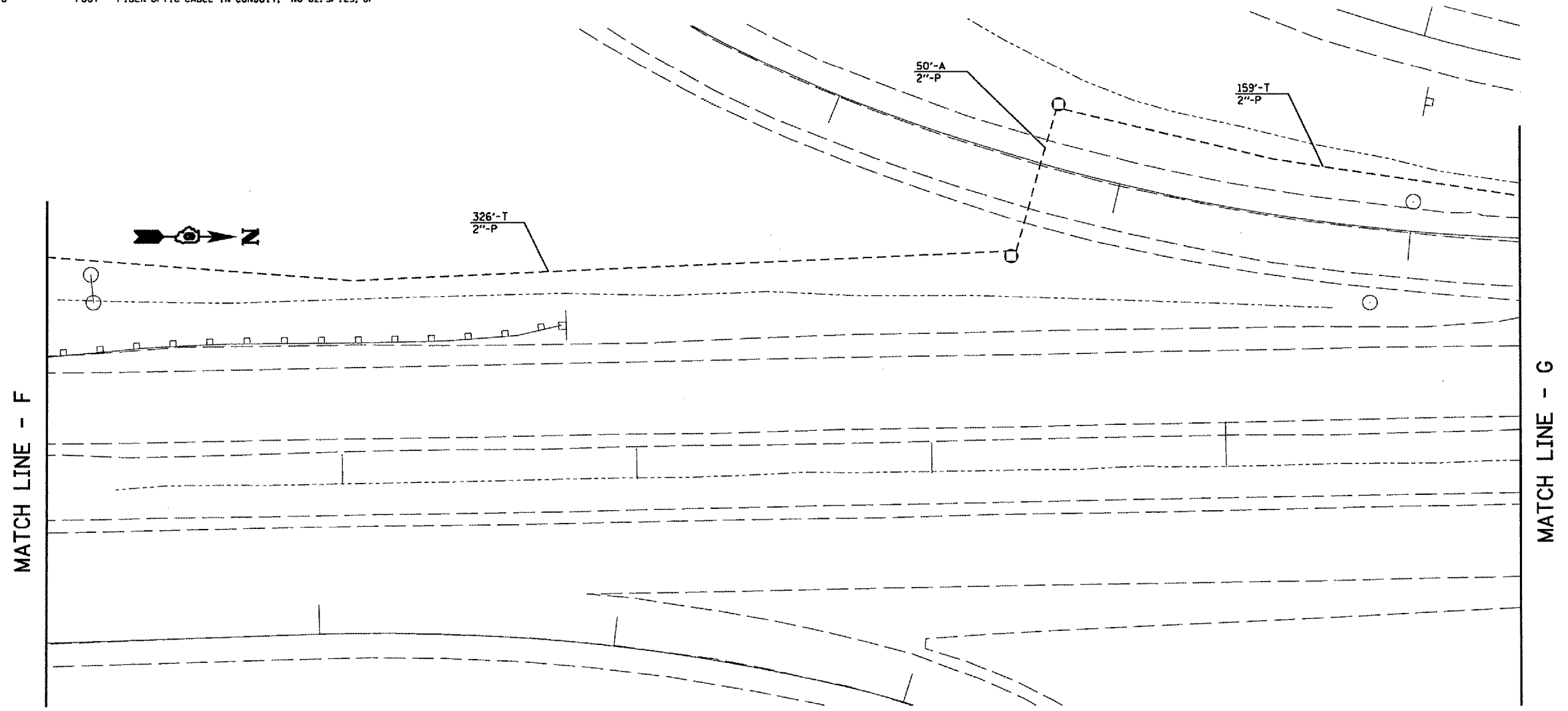

PLOT DATE * DATE *
 FILE NAME * FILE *
 PLOT SCALE * SCALE *
 USER NAME * USER *

REVISIONS	
NAME	DATE

ILLINOIS DEPARTMENT OF TRANSPORTATION
PROPOSED FIBER OPTIC
 STEVENSON DR
 D-6 ITS
 SANGAMON COUNTY

SCALE: VERT. 1" = 20'
 HORIZ. 1" = 20'
 DATE MAY 2005

DRAWN BY KDA
 CHECKED BY

F.A. RTE.	SECTION	COUNTY	TOTAL SHEETS	SHEET NO.
	D-6 ITS #1	SANGAMON		17
STA.		TO STA.		
FED. RD. DIST. NO.		ILLINOIS FED. AID PROJECT		

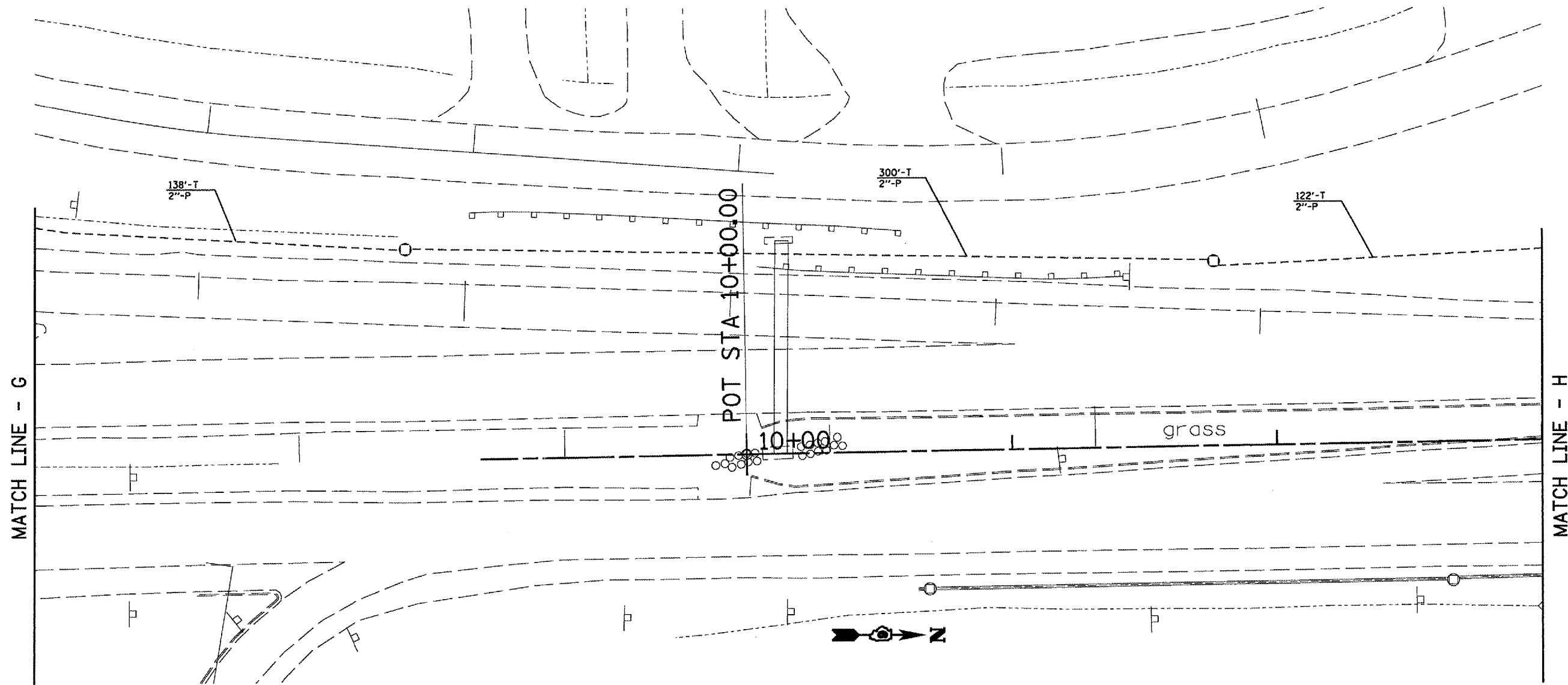

FIBER OPTIC QUANTITIES

QUANTITY	UNIT	ITEM
560.0	FOOT	CONDUIT IN TRENCH, 2" DIA., PVC
2	EACH	JUNCTION BOX (SPECIAL)
560.0	FOOT	TRENCH AND BACKFILL FOR ELECTRICAL WORK
563.0	FOOT	FIBER OPTIC CABLE IN CONDUIT, NO 62.5/125, BF

REVISIONS	
NAME	DATE

ILLINOIS DEPARTMENT OF TRANSPORTATION
PROPOSED FIBER OPTIC
 STEVENSON DR
 D-6 ITS
 SANGAMON COUNTY
 SCALE: VERT. 1" = 20'
 HORIZ. 1" = 40'
 DATE MAY 2005
 DRAWN BY KDA
 CHECKED BY

PLOT DATE * * * * *
 FILE NAME * * * * *
 PLOT SCALE * * * * *
 USER NAME * * * * *

F.A. RTE.	SECTION	COUNTY	TOTAL SHEETS	SHEET NO.
	D-6 ITS #1	SANGAMON		18
STA.		TO STA.		
FED. ROAD DIST. NO.		ILLINOIS FED. AID PROJECT		

NOTES:

- FIBER OPTIC SHALL BE INSTALLED INTO EXISTING TRAFFIC SIGNAL CONTROLLER CABINET AT 6TH/HAZEL DELL TO ALLOW FOR THE TRANSFER OF SERIAL DATA BETWEEN THE DIST. 6 COMMUNICATION CENTER AND THE AUTOSCOPE VIDEO DETECTION SYSTEM. SEE 6TH/HAZEL DELL CABINET DETAIL.

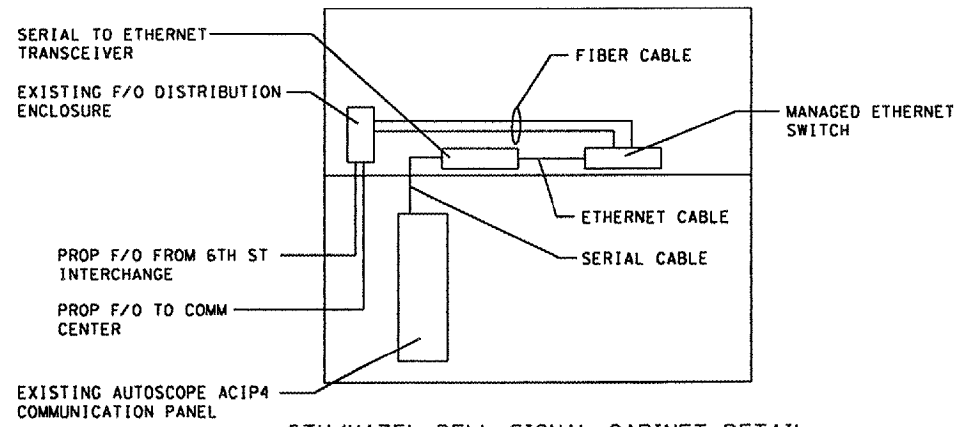

6TH/HAZEL DELL SIGNAL CABINET DETAIL

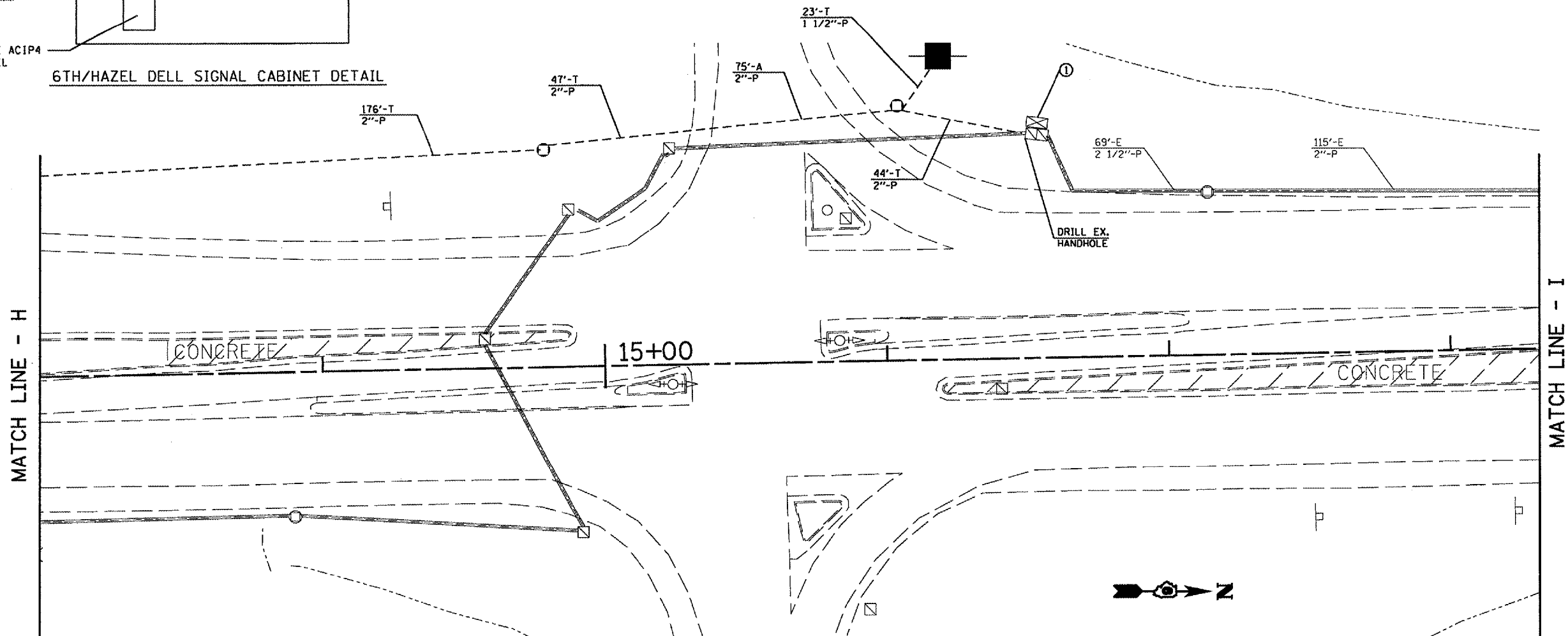

FIBER OPTIC QUANTITIES

QUANTITY	UNIT	ITEM
23.0	FOOT	CONDUIT IN TRENCH, 1 1/2" DIA., PVC
267.0	FOOT	CONDUIT IN TRENCH, 2" DIA., PVC
75.0	FOOT	CONDUIT, AUGERED, 2" DIA., PVC
2	EACH	JUNCTION BOX (SPECIAL)
290.0	FOOT	TRENCH AND BACKFILL FOR ELECTRICAL WORK
543.5	FOOT	FIBER OPTIC CABLE IN CONDUIT, NO 62.5/125, 8F
1	EACH	DRILL EXISTING HANDHOLE

REVISIONS	
NAME	DATE

ILLINOIS DEPARTMENT OF TRANSPORTATION
PROPOSED FIBER OPTIC
 STEVENSON DR
 D-6 ITS
 SANGAMON COUNTY

SCALE: VERT. 1" = 20'
 HORIZ. DATE MAY 2005

DRAWN BY KDA
 CHECKED BY

F.A. RTE.	SECTION	COUNTY	TOTAL SHEETS	SHEET NO.
	D-6 ITS #1	SANGAMON		79
STA.		TO STA.		
FED. ROAD DIST. NO.	ILLINOIS FED. AID PROJECT			

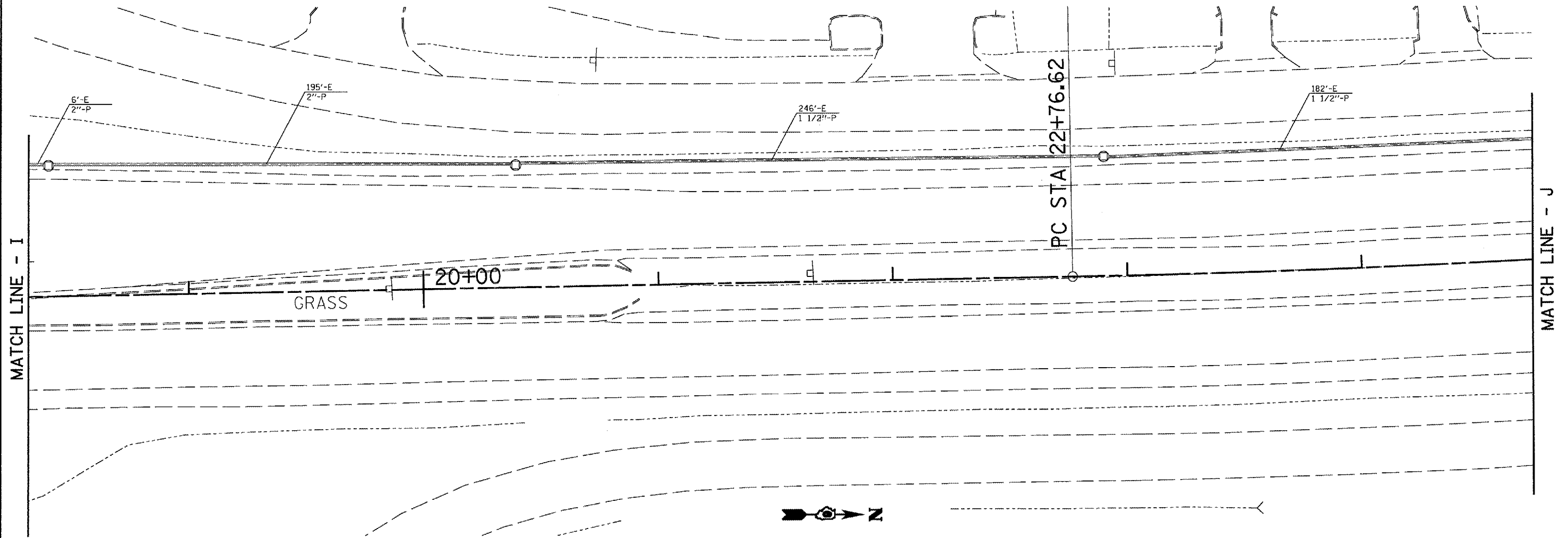

FIBER OPTIC QUANTITIES

QUANTITY	UNIT	ITEM
633.5	FOOT	FIBER OPTIC CABLE IN CONDUIT, NO 62.5/125, 8F

DATE
FILE NAME
PLOT SCALE
USER NAME

REVISIONS	
NAME	DATE

ILLINOIS DEPARTMENT OF TRANSPORTATION
PROPOSED FIBER OPTIC
 STEVENSON DR
 D-6 ITS
 SANGAMON COUNTY
 SCALE: VERT. 1" = 20'
 HORIZ. DATE MAY 2005
 DRAWN BY KDA
 CHECKED BY

F.A. RTE.	SECTION	COUNTY	TOTAL SHEETS	SHEET NO.
	D-6 ITS #1	SANGAMON		20
STA.	TO STA.			
FED. ROAD DIST. NO.	ILLINOIS	FED. AID PROJECT		

FIBER OPTIC QUANTITIES

QUANTITY	UNIT	ITEM
611.5	FOOT	FIBER OPTIC CABLE IN CONDUIT, NO 62.5/125, 8F

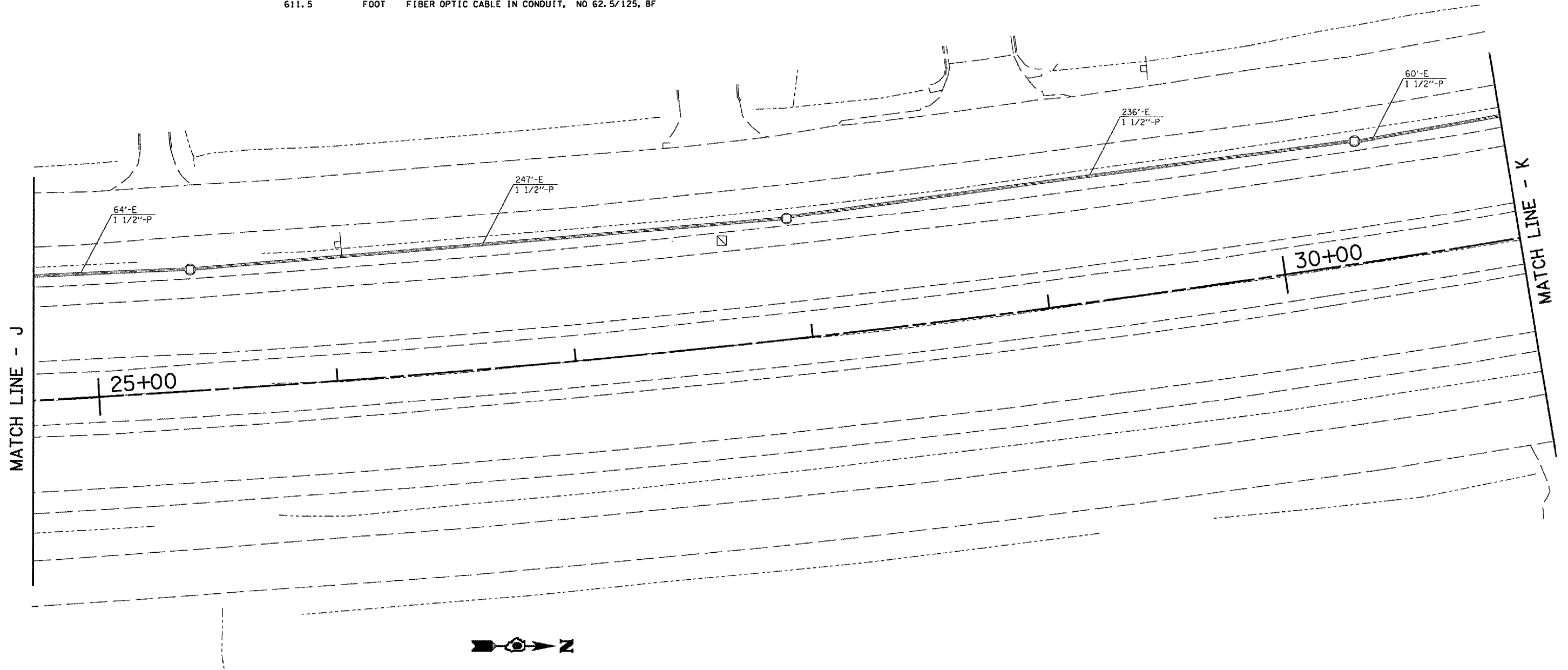

MATCH LINE - J

MATCH LINE - K

PLOT DATE * DATE*
 FILE NAME * FILEL*
 PLOT SCALE * SCALE*
 USER NAME * USER*

REVISIONS	
NAME	DATE

ILLINOIS DEPARTMENT OF TRANSPORTATION
PROPOSED FIBER OPTIC
 STEVENSON DR
 D-6 ITS
 SANGAMON COUNTY

SCALE: VERT. 1" = 20'
 HORIZ. DATE MAY 2005

DRAWN BY KDA
 CHECKED BY

F.A. RTE.	SECTION	COUNTY	TOTAL SHEETS	SHEET NO.
	D-6 ITS #1	SANGAMON		21
STA.		TO STA.		
FED. ROAD DIST. NO.	ILLINOIS	FED. AID PROJECT		

FIBER OPTIC QUANTITIES

QUANTITY	UNIT	ITEM
603.0	FOOT	FIBER OPTIC CABLE IN CONDUIT, NO 62.5/125, 8F

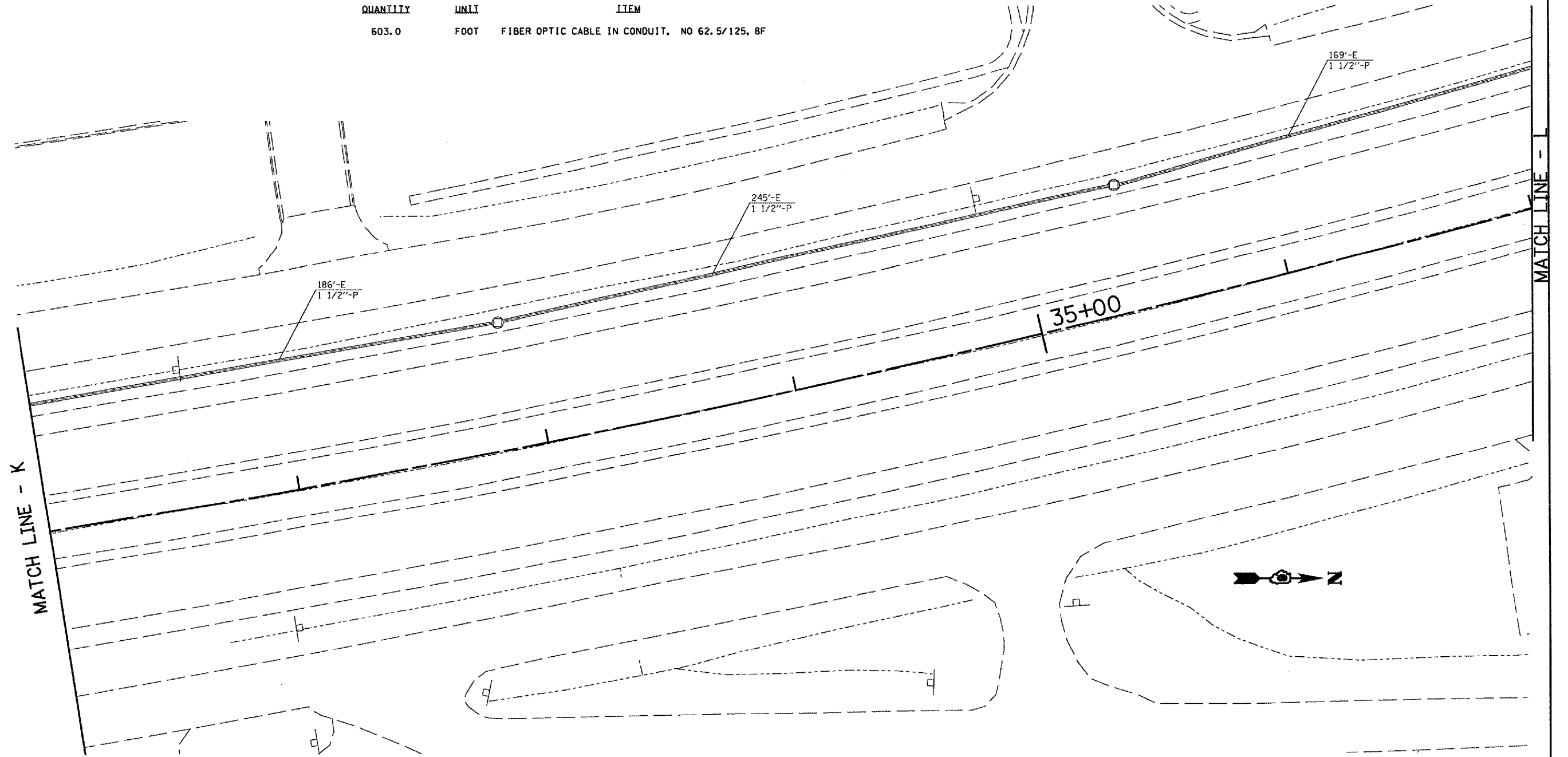

PLOT DATE * DATE*
 FILE NAME * FILE*
 PLOT SCALE * SCALE*
 USER NAME * USER*

REVISIONS	
NAME	DATE

ILLINOIS DEPARTMENT OF TRANSPORTATION
PROPOSED FIBER OPTIC
 STEVENSON DR
 D-6 ITS
 SANGAMON COUNTY

SCALE: VERT. 1" = 20'
 HORIZ. 1" = 20'
 DATE MAY 2005

DRAWN BY KDA
 CHECKED BY

F.A. RTE.	SECTION	COUNTY	TOTAL SHEETS	SHEET NO.
	D-6 ITS #1	SANGAMON		22
STA.		TO STA.		
FED. ROAD DIST. NO.	ILLINOIS	FED. AID PROJECT		

FIBER OPTIC QUANTITIES

QUANTITY	UNIT	ITEM
578.0	FOOT	FIBER OPTIC CABLE IN CONDUIT, NO 62.5/125, 8F

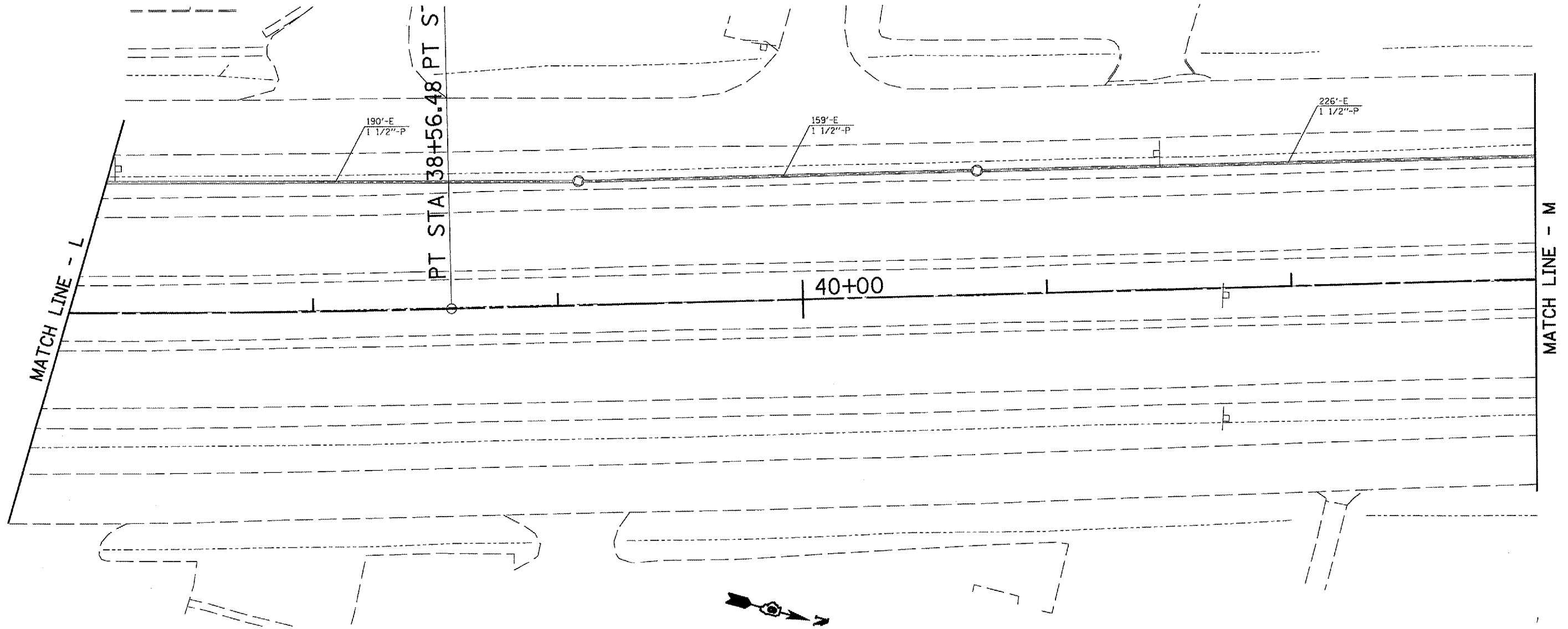

PLOT DATE * DATE
 FILE NAME * FILEL
 PLOT SCALE * SCAL
 USER NAME * USER

REVISIONS	
NAME	DATE

ILLINOIS DEPARTMENT OF TRANSPORTATION
PROPOSED FIBER OPTIC
 STEVENSON DR
 D-6 ITS
 SANGAMON COUNTY
 SCALE: VERT. 1" = 20'
 HORIZ. 1" = 20'
 DATE MAY 2005
 DRAWN BY KDA
 CHECKED BY

F.A. RTE.	SECTION	COUNTY	TOTAL SHEETS	SHEET NO.
	D-6 ITS #1	SANGAMON		23
STA.		TO STA.		
FED. ROAD DIST. NO.		ILLINOIS FED. AID PROJECT		

FIBER OPTIC QUANTITIES

QUANTITY	UNIT	ITEM
664.5	FOOT	FIBER OPTIC CABLE IN CONDUIT, NO 62.5/125, BF

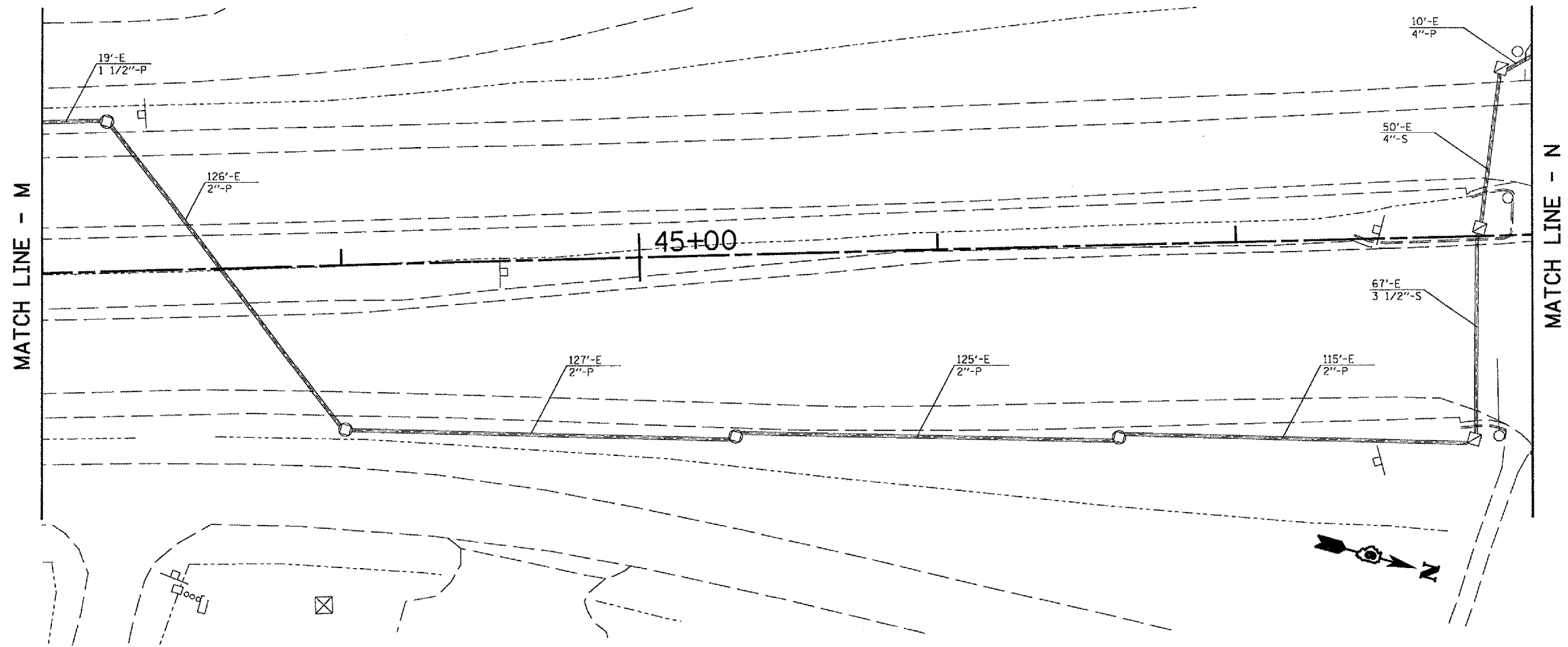

PLOT DATE * DATE *
 FILE NAME * FILE *
 PLOT SCALE * SCALE *
 USER NAME * USER *

REVISIONS	
NAME	DATE

ILLINOIS DEPARTMENT OF TRANSPORTATION
PROPOSED FIBER OPTIC
 STEVENSON DR
 D-6 ITS
 SANGAMON COUNTY

SCALE: VERT. 1" = 20'
 HORIZ. 1" = 20'
 DATE MAY 2005
 DRAWN BY KDA
 CHECKED BY

F.A. RTE.	SECTION	COUNTY	TOTAL SHEETS	SHEET NO.
	D-6 ITS *1	SANGAMON		24
STA.		TO STA.		
FED. ROAD DIST. NO.	ILLINOIS	FED. AID PROJECT		

FIBER OPTIC QUANTITIES

QUANTITY	UNIT	ITEM
213.0	FOOT	CONDUIT IN TRENCH, 1 1/2" DIA., PVC
1	EACH	DRILL EXISTING JUNCTION BOX
213.0	FOOT	TRENCH AND BACKFILL FOR ELECTRICAL WORK
624.5	FOOT	FIBER OPTIC CABLE IN CONDUIT, NO 62.5/125, 8F

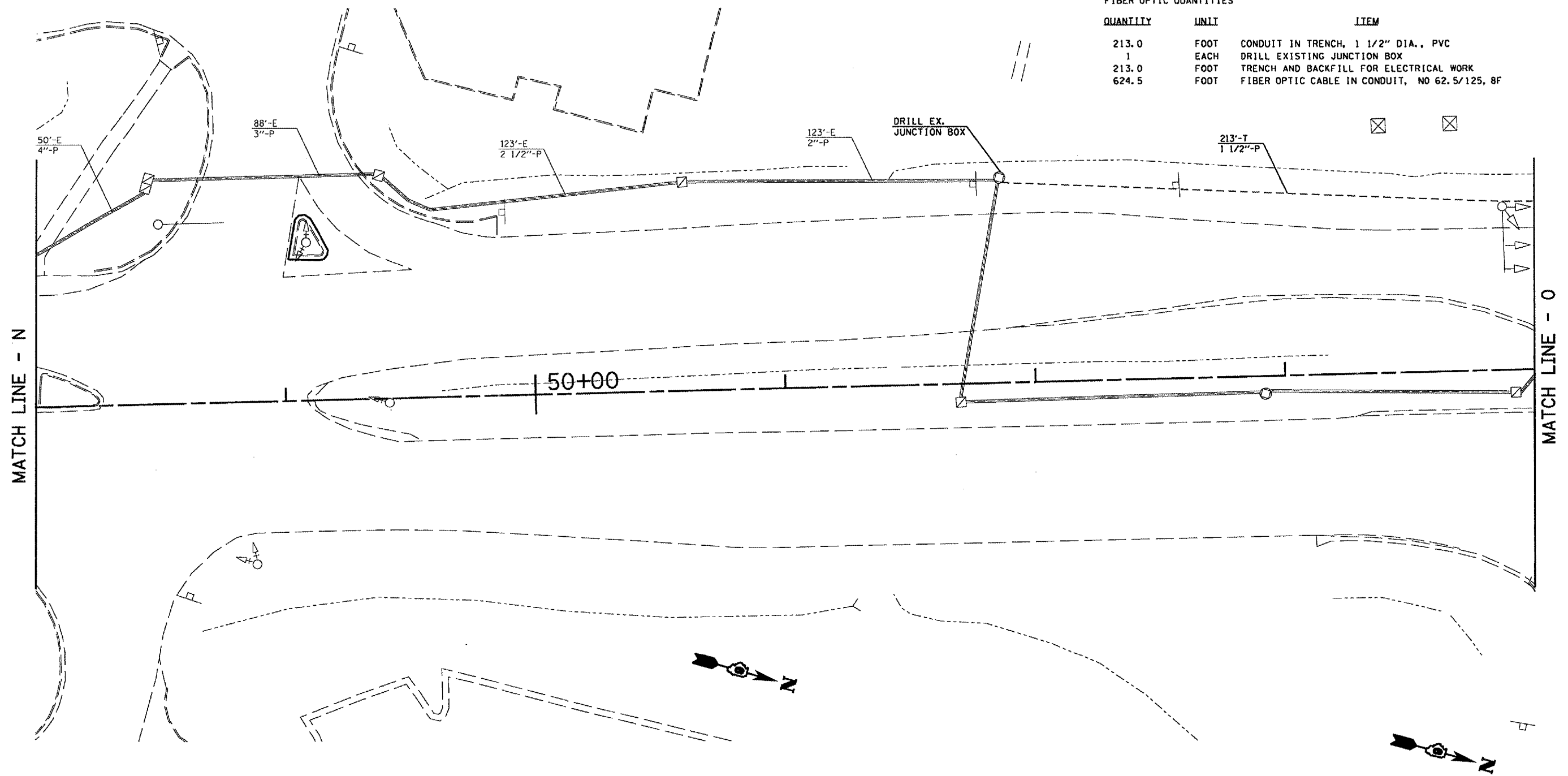

PLOT DATE * DATES
 FILE NAME * #FILES
 PLOT SCALE * #Scales
 USER NAME * #USERS

REVISIONS	
NAME	DATE

ILLINOIS DEPARTMENT OF TRANSPORTATION
PROPOSED FIBER OPTIC
 STEVENSON DR
 D-6 ITS
 SANGAMON COUNTY
 SCALE: VERT. 1" = 20'
 DATE: MAY 2005
 DRAWN BY: KDA
 CHECKED BY:

F.A. RTE.	SECTION	COUNTY	TOTAL SHEETS	SHEET NO.
	D-6 ITS #1	SANGAMON		25
STA.		TO STA.		
FED. ROAD DIST. NO.	ILLINOIS FED. AID PROJECT			

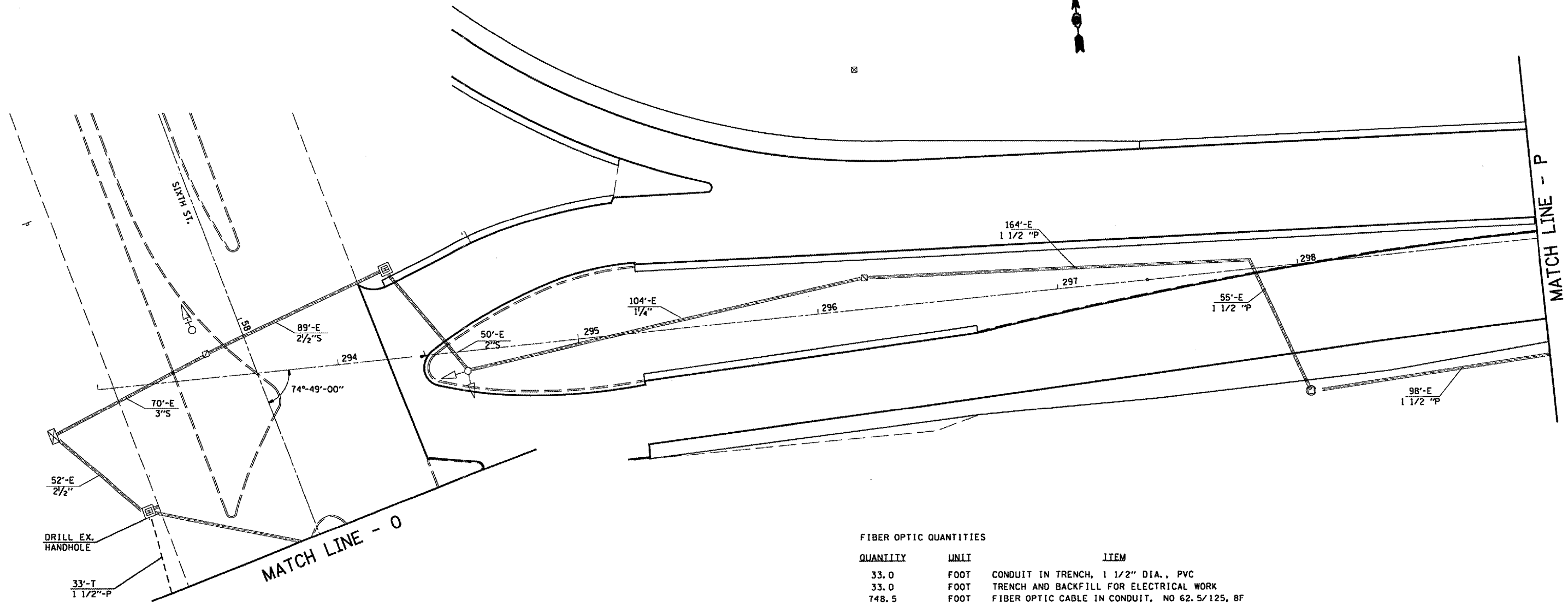

FIBER OPTIC QUANTITIES

QUANTITY	UNIT	ITEM
33.0	FOOT	CONDUIT IN TRENCH, 1 1/2" DIA., PVC
33.0	FOOT	TRENCH AND BACKFILL FOR ELECTRICAL WORK
748.5	FOOT	FIBER OPTIC CABLE IN CONDUIT, NO 62.5/125, 8F
1	EACH	DRILL EXISTING HANDHOLE

PLOT DATE * DATES *
 FILE NAME * FILES *
 PLOT SCALE * SCALES *
 USER NAME * USERS *

REVISIONS	
NAME	DATE

ILLINOIS DEPARTMENT OF TRANSPORTATION
PROPOSED FIBER OPTIC
 STEVENSON DR
 D-6 ITS
 SANGAMON COUNTY
 SCALE: VERT. 1" = 20'
 HORIZ. DATE MAY 2005
 DRAWN BY KDA
 CHECKED BY

F.A. RTE.	SECTION	COUNTY	TOTAL SHEETS	SHEET NO.
	D-6 ITS #1	SANGAMON		26
STA.		TO STA.		
FED. ROAD DIST. NO.	ILLINOIS	FED. AID PROJECT		

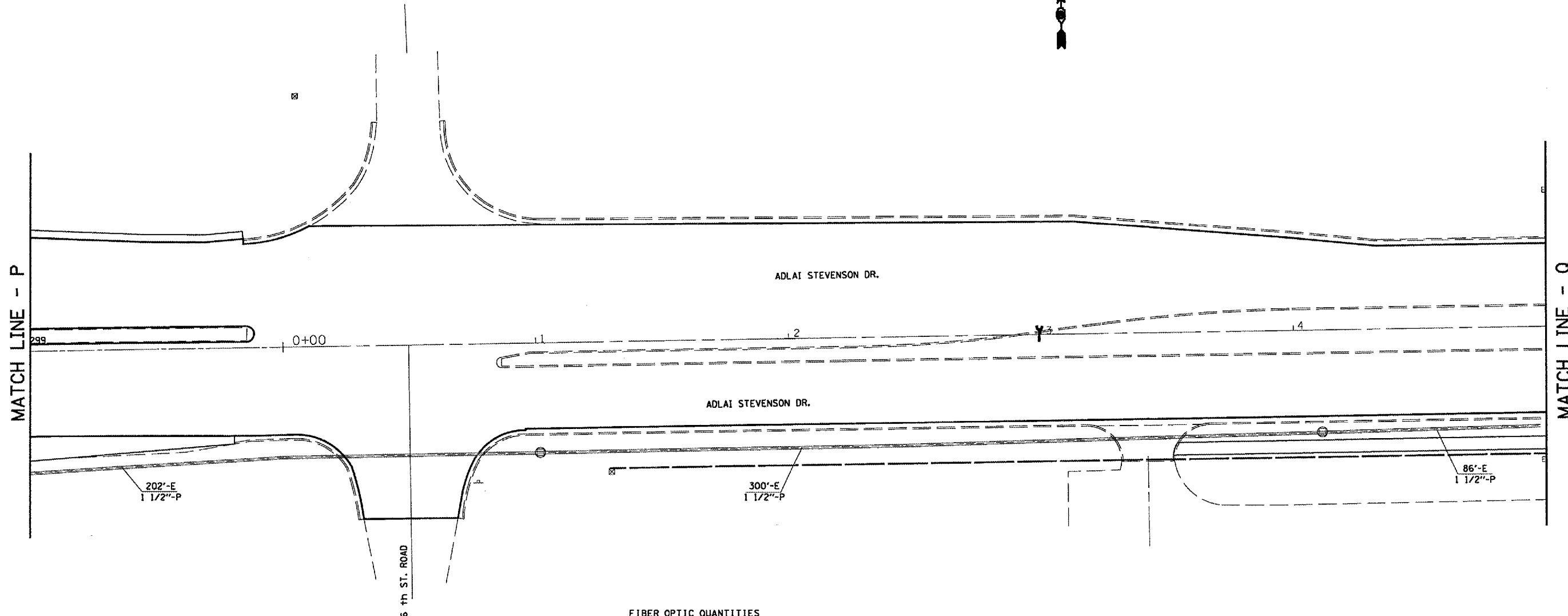

FIBER OPTIC QUANTITIES

QUANTITY	UNIT	ITEM
591.0	FOOT	FIBER OPTIC CABLE IN CONDUIT, NO 62.5/125, 8F

TIES.

PLOT DATE * WATER
FILE NAME * #FILEL
PLOT SCALE * #SCALE
USER NAME * #USER

REVISIONS	
NAME	DATE

ILLINOIS DEPARTMENT OF TRANSPORTATION
PROPOSED FIBER OPTIC
STEVENSON DR
D-6 ITS
SANGAMON COUNTY
SCALE: VERT. 1" = 20'
HORIZ. 1" = 20'
DATE MAY 2005
DRAWN BY KDA
CHECKED BY

F.A. RTE.	SECTION	COUNTY	TOTAL SHEETS	SHEET NO.
	D-6 ITS #1	SANGAMON		27
STA.	TO STA.			
FED. ROAD DIST. NO.	ILLINOIS	FED. AID PROJECT		

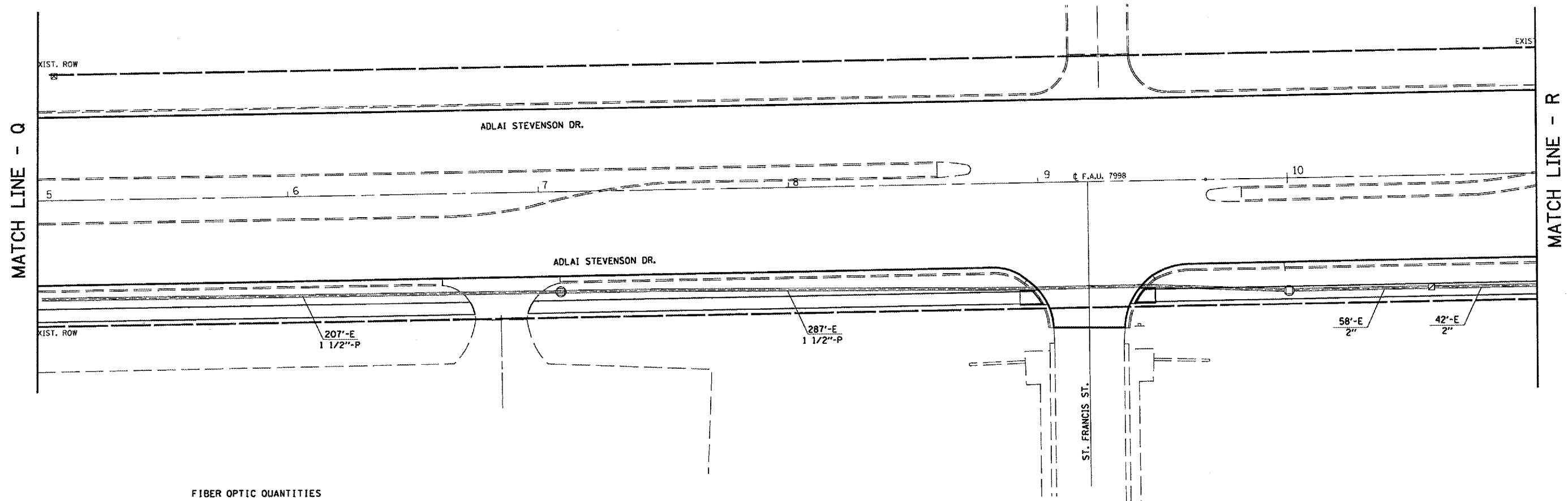

FIBER OPTIC QUANTITIES

QUANTITY	UNIT	ITEM
603.5	FOOT	FIBER OPTIC CABLE IN CONDUIT, NO 62.5/125, 8F

TIES.

REVISIONS	
NAME	DATE

ILLINOIS DEPARTMENT OF TRANSPORTATION
PROPOSED FIBER OPTIC
 STEVENSON DR
 D-6 ITS
 SANGAMON COUNTY

SCALE: VERT. 1" = 20'
 HORIZ. 1" = 20'
 DATE MAY 2005

DRAWN BY KDA
 CHECKED BY

PLOT DATE * DATE *
 FILE NAME * FILE *
 PLOT SCALE * SCALE *
 USER NAME * USER *

F.A. RTE.	SECTION	COUNTY	TOTAL SHEETS	SHEET NO.
	D-6 ITS *1	SANGAMON		28
STA.		TO STA.		
FED. ROAD DIST. NO.		ILLINOIS FED. AID PROJECT		

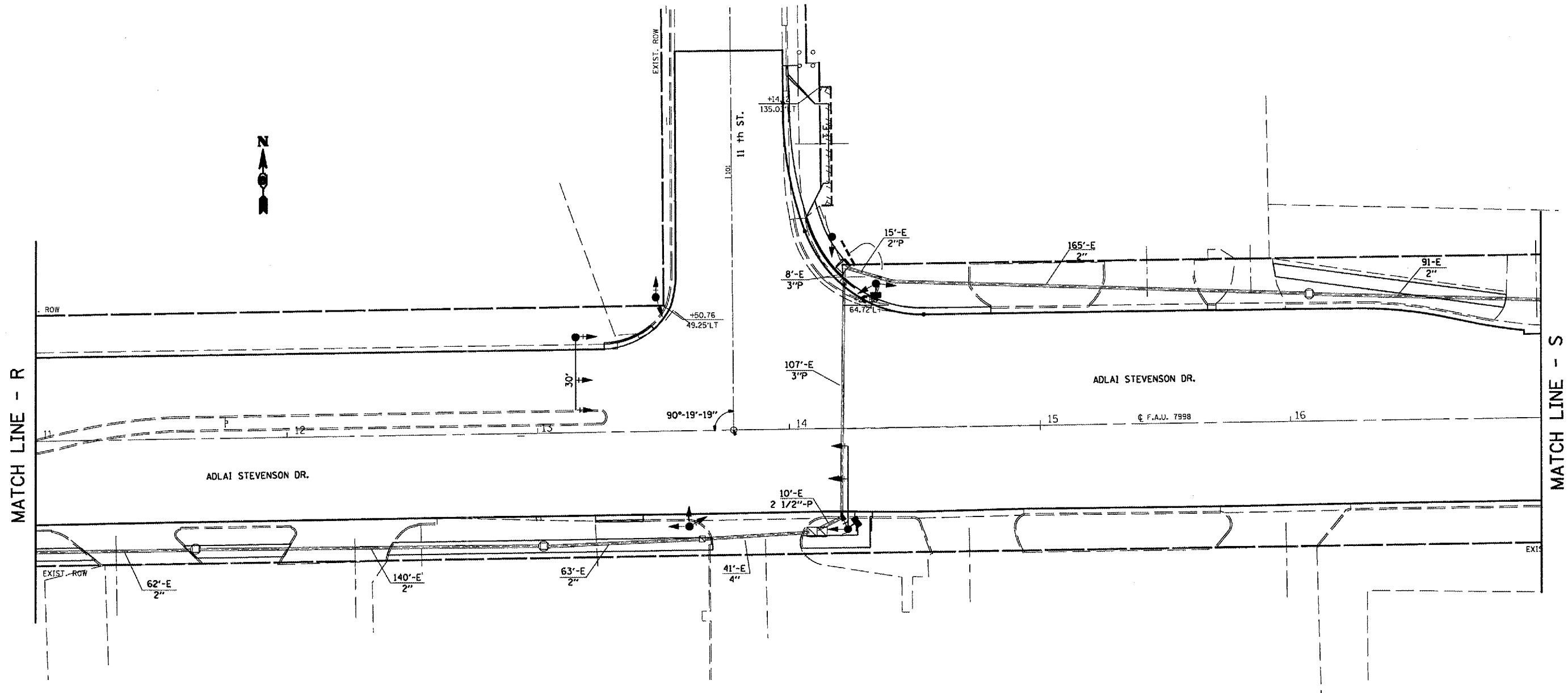

FIBER OPTIC QUANTITIES

QUANTITY	UNIT	ITEM
732.5	FOOT	FIBER OPTIC CABLE IN CONDUIT, NO 62.5/125, 8F

DATE *
 FILE NAME *
 PLOT SCALE *
 USER NAME *

REVISIONS	
NAME	DATE

ILLINOIS DEPARTMENT OF TRANSPORTATION
PROPOSED FIBER OPTIC
 STEVENSON DR
 D-6 ITS
 SANGAMON COUNTY

SCALE: VERT. 1" = 20'
 HORIZ. 1" = 40'
 DATE MAY 2005

DRAWN BY KDA
 CHECKED BY

F.A. RTE.	SECTION	COUNTY	TOTAL SHEETS	SHEET NO.
	D-6 ITS #1	SANGAMON		29
STA.		TO STA.		
FED. ROAD DIST. NO.		ILLINOIS FED. AID PROJECT		

N
A
O
N

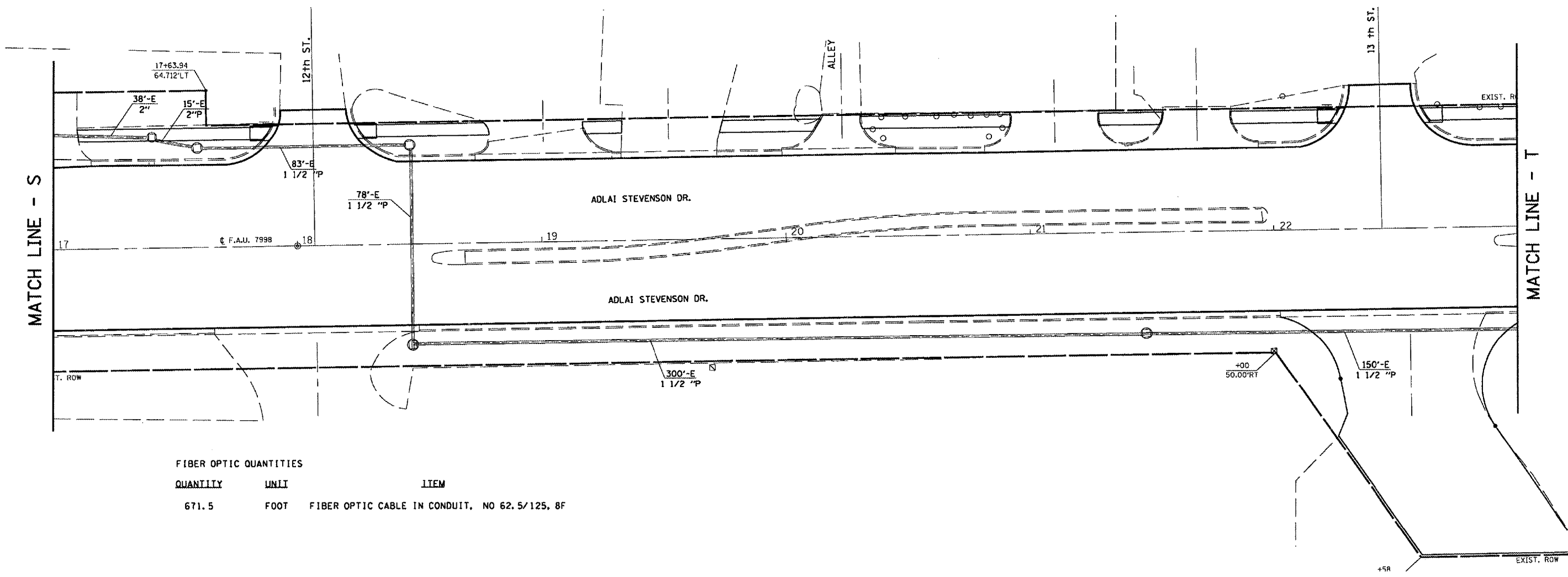

FIBER OPTIC QUANTITIES

QUANTITY	UNIT	ITEM
671.5	FOOT	FIBER OPTIC CABLE IN CONDUIT, NO 62.5/125, 8F

PLOT DATE * DATEP
 FILE NAME * #FILEA
 PLOT SCALE * #SCALEA
 USER NAME * #USERB

REVISIONS	
NAME	DATE

ILLINOIS DEPARTMENT OF TRANSPORTATION
PROPOSED FIBER OPTIC
 STEVENSON DR
 D-6 ITS
 SANGAMON COUNTY

SCALE: VERT. 1" = 20'
 HORIZ. 1" = 40'
 DATE MAY 2005

DRAWN BY KDA
 CHECKED BY

F.A. RTE.	SECTION	COUNTY	TOTAL SHEETS	SHEET NO.
	D-6 ITS #1	SANGAMON		30
STA.		TO STA.		
FED. ROAD DIST. NO.	ILLINOIS	FED. AID PROJECT		

N
A
S
N

14th ST.

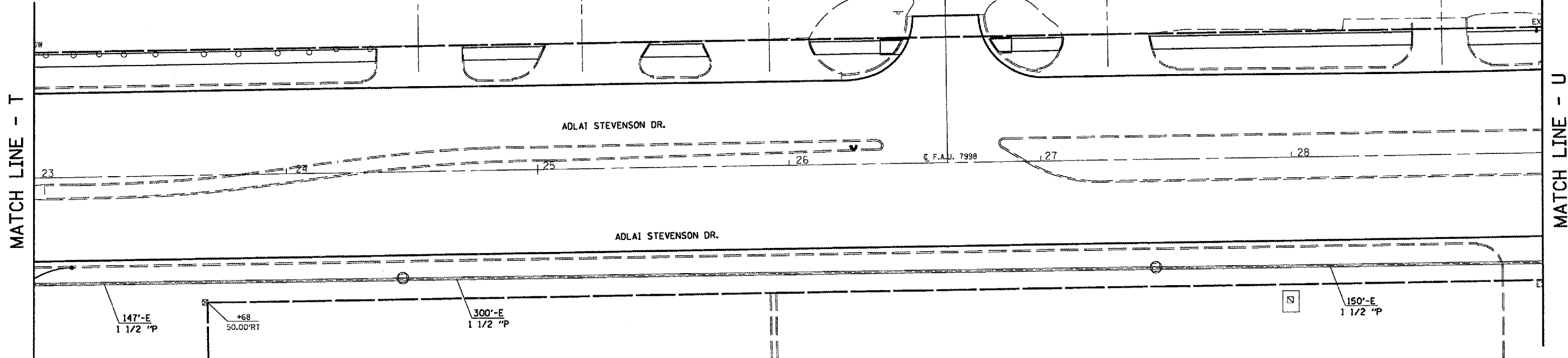

FIBER OPTIC QUANTITIES

QUANTITY	UNIT	ITEM
600.0	FOOT	FIBER OPTIC CABLE IN CONDUIT, NO 62.5/125, 8F

EXIST. ROW +68 135.00'RT

REVISIONS	
NAME	DATE

ILLINOIS DEPARTMENT OF TRANSPORTATION
PROPOSED FIBER OPTIC
 STEVENSON DR
 D-6 ITS
 SANGAMON COUNTY

SCALE: VERT. 1" = 20'
 HORIZ. DATE MAY 2005

DRAWN BY KDA
 CHECKED BY

PLOT DATE: 5/20/05
 FILE NAME: 72A00.DWG
 PLOT SCALE: 1/4" = 1'-0"
 USER: KDA

F.A. RTE.	SECTION	COUNTY	TOTAL SHEETS	SHEET NO.
	D-6 ITS #1	SANGAMON		31
STA.		TO STA.		
FED. ROAD DIST. NO.	ILLINOIS	FED. AID PROJECT		

N
A
O
N

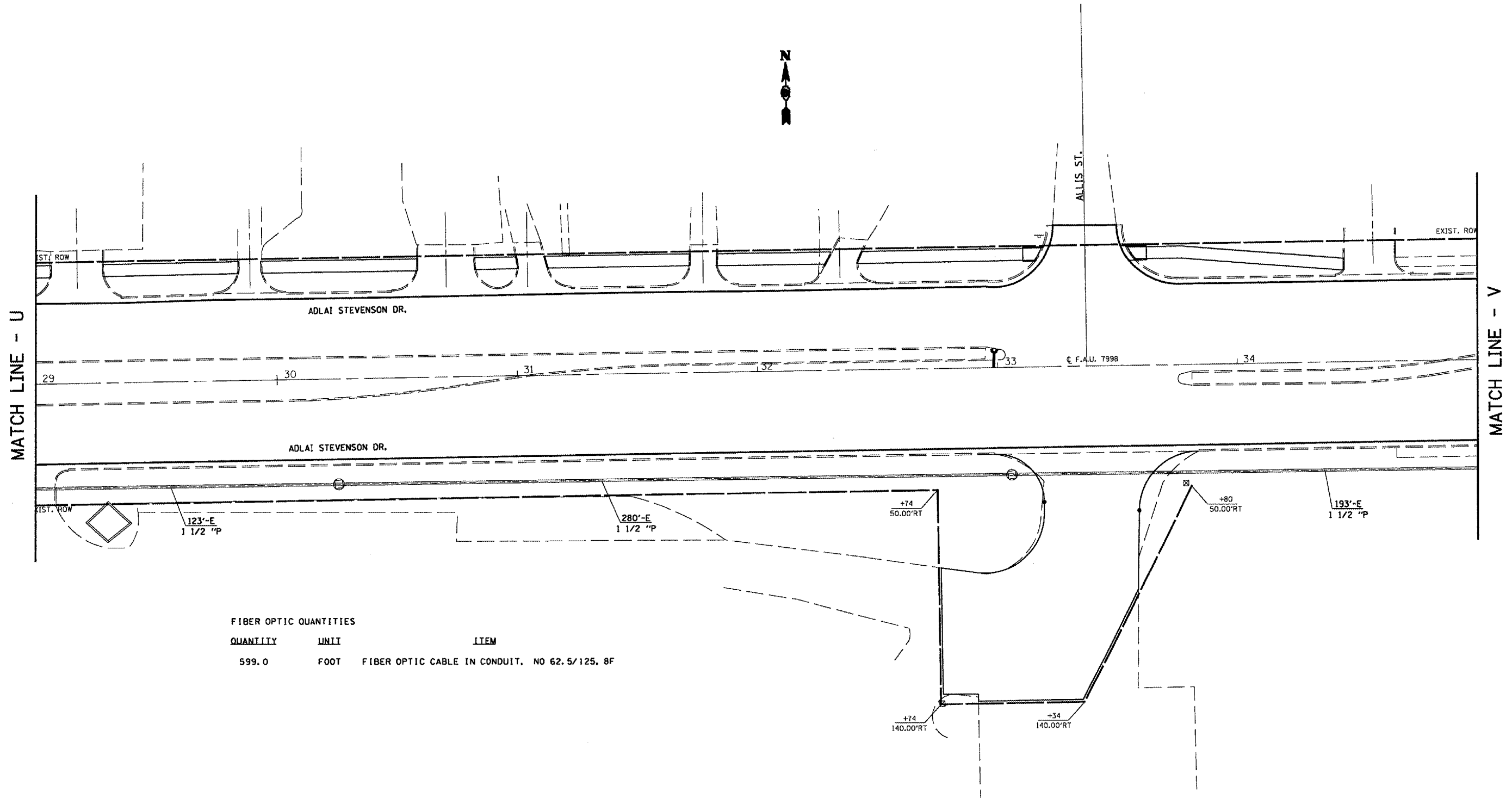

FIBER OPTIC QUANTITIES

QUANTITY	UNIT	ITEM
599.0	FOOT	FIBER OPTIC CABLE IN CONDUIT, NO 62.5/125, 8F

REVISIONS	
NAME	DATE

ILLINOIS DEPARTMENT OF TRANSPORTATION
PROPOSED FIBER OPTIC
 STEVENSON DR
 D-6 ITS
 SANGAMON COUNTY
 SCALE: VERT. 1" = 20'
 HORIZ. DATE MAY 2005
 DRAWN BY KDA
 CHECKED BY

PLOT DATE * DATE
 FILE NAME * FILEL
 PLOT SCALE * 80000
 USER NAME * RUBEN

F.A. RTE.	SECTION	COUNTY	TOTAL SHEETS	SHEET NO.
	D-6 ITS #1	SANGAMON		32
STA.		TO STA.		
FED. ROAD DIST. NO.	ILLINOIS	FED. AID PROJECT		

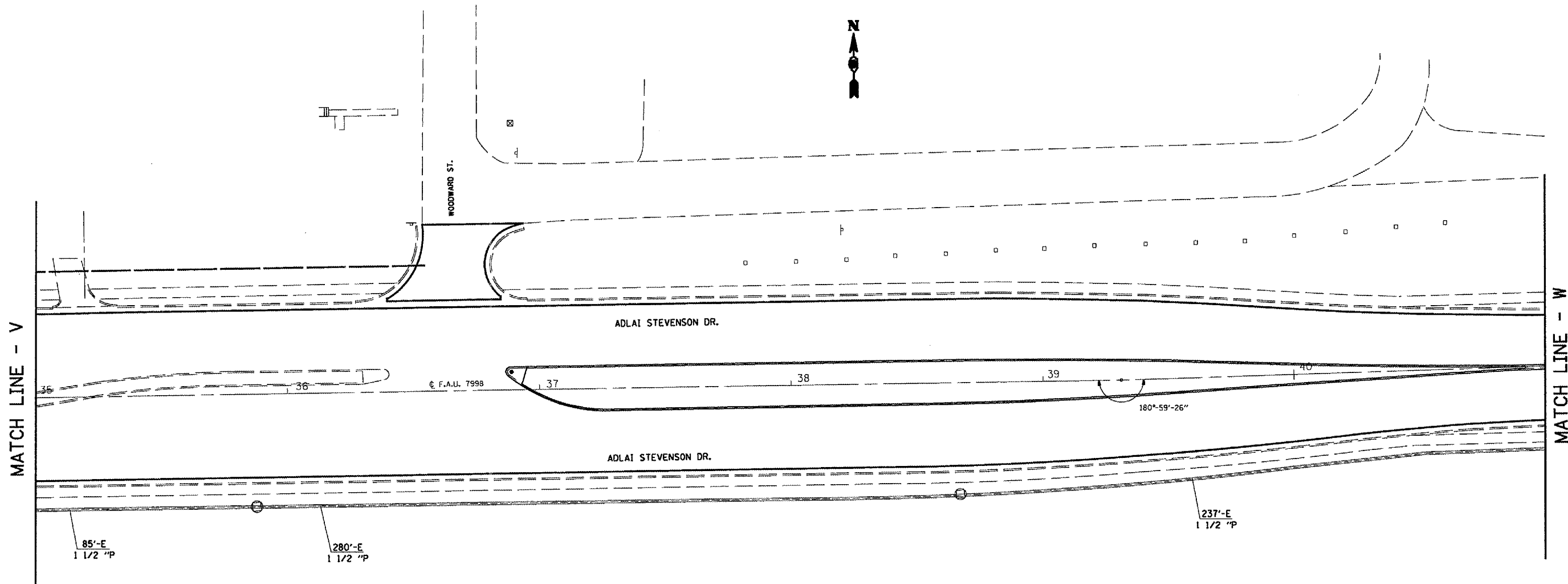

FIBER OPTIC QUANTITIES

QUANTITY	UNIT	ITEM
605.0	FOOT	FIBER OPTIC CABLE IN CONDUIT, NO 62.5/125, 8F

PLOT DATE *
 FILE NAME *
 PLOT SCALE *
 USER NAME *

REVISIONS	
NAME	DATE

ILLINOIS DEPARTMENT OF TRANSPORTATION
PROPOSED FIBER OPTIC
 STEVENSON DR
 D-6 ITS
 SANGAMON COUNTY
 SCALE: VERT. 1" = 20'
 HORIZ. 1" = 20'
 DATE MAY 2005
 DRAWN BY KDA
 CHECKED BY

F.A. RTE.	SECTION	COUNTY	TOTAL SHEETS	SHEET NO.
	D-6 ITS #1	SANGAMON		33
STA.		TO STA.		
FED. ROAD DIST. NO.	ILLINOIS	FED. AID PROJECT		

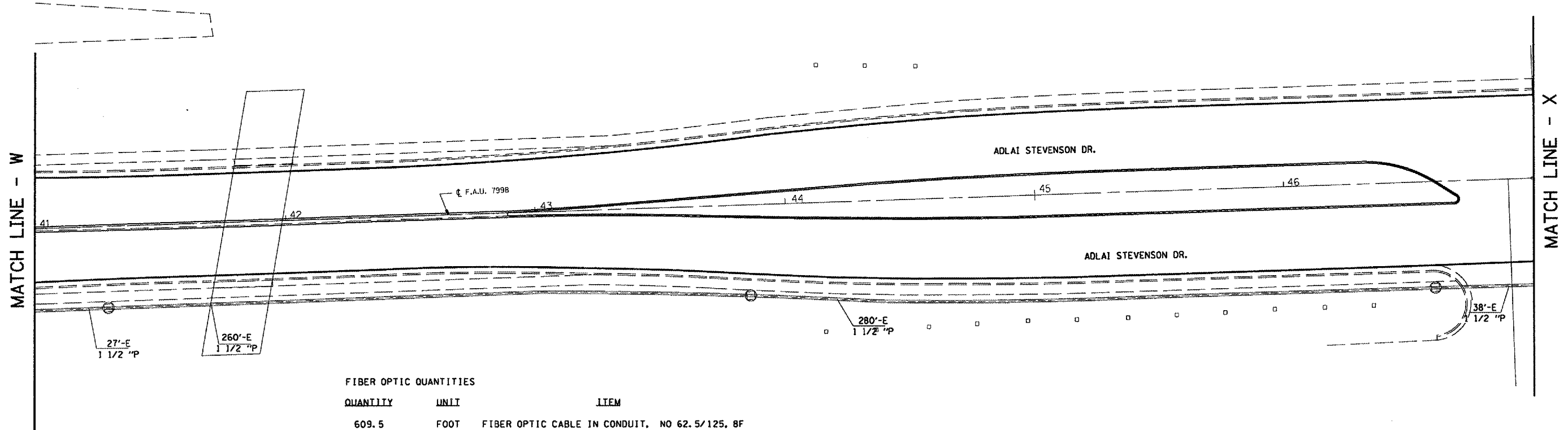

FIBER OPTIC QUANTITIES

QUANTITY	UNIT	ITEM
609.5	FOOT	FIBER OPTIC CABLE IN CONDUIT, NO 62.5/125, 8F

REVISIONS	
NAME	DATE

ILLINOIS DEPARTMENT OF TRANSPORTATION
PROPOSED FIBER OPTIC
 STEVENSON DR
 D-6 ITS
 SANGAMON COUNTY
 SCALE: VERT. 1" = 20'
 HORIZ. 1" = 20'
 DATE MAY 2005
 DRAWN BY KDA
 CHECKED BY

PLOT DATE: * DATE *
 FILE NAME: * FILE *
 PLOT SCALE: * SCALE *
 USER NAME: * USER *

F.A. RTE.	SECTION	COUNTY	TOTAL SHEETS	SHEET NO.
	D-6 ITS #1	SANGAMON		34
STA.		TO STA.		
FED. ROAD DIST. NO.		ILLINOIS FED. AID PROJECT		

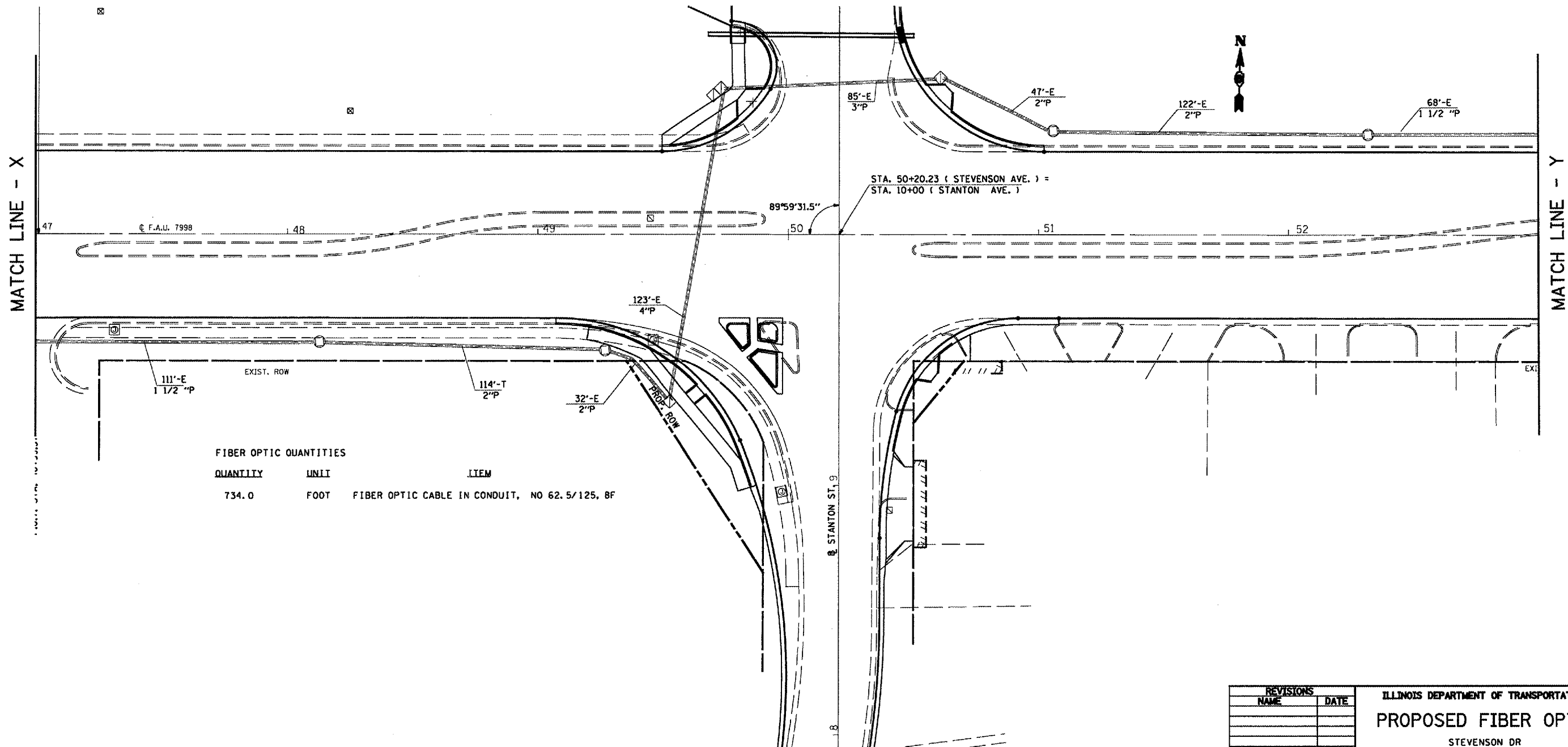

FIBER OPTIC QUANTITIES

QUANTITY	UNIT	ITEM
734.0	FOOT	FIBER OPTIC CABLE IN CONDUIT, NO 62.5/125, 8F

REVISIONS	
NAME	DATE

ILLINOIS DEPARTMENT OF TRANSPORTATION
PROPOSED FIBER OPTIC
 STEVENSON DR
 D-6 ITS
 SANGAMON COUNTY

SCALE: VERT. 1" = 20'
 HORIZ. 1" = 40'
 DATE MAY 2005
 DRAWN BY KDA
 CHECKED BY

PLOT DATE * DATE\$
 FILE NAME * #FILEL\$
 PLOT SCALE * #SCALE\$
 USER NAME * #USER\$

F.A. RTE.	SECTION	COUNTY	TOTAL SHEETS	SHEET NO.
	D-6 ITS #1	SANGAMON		35
STA.		TO STA.		
FED. ROAD DIST. NO.		ILLINOIS FED. AID PROJECT		

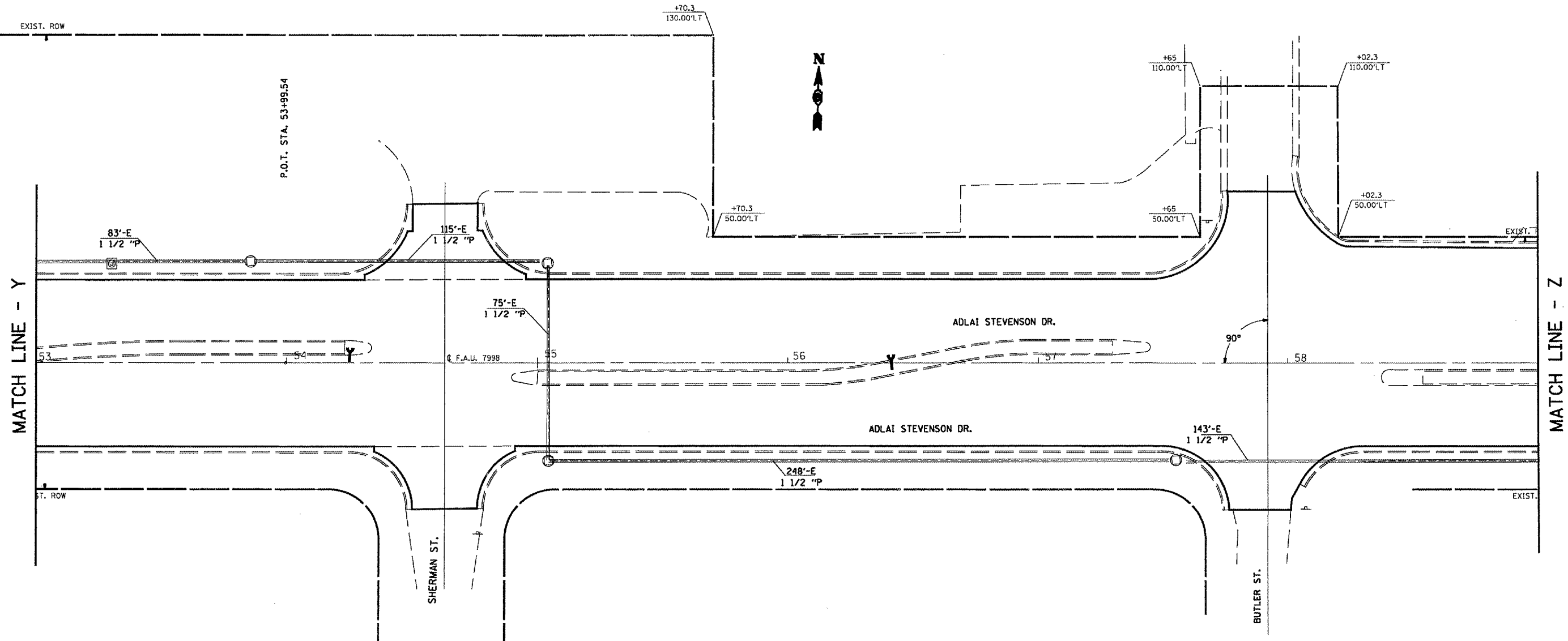

FIBER OPTIC QUANTITIES

QUANTITY	UNIT	ITEM
670.0	FOOT	FIBER OPTIC CABLE IN CONDUIT, NO 62.5/125, 8F

PLOT DATE * DATE
 FILE NAME * FILE
 PLOT SCALE * SCALE
 USER NAME * USER

REVISIONS	
NAME	DATE

ILLINOIS DEPARTMENT OF TRANSPORTATION
PROPOSED FIBER OPTIC
 STEVENSON DR
 D-6 ITS
 SANGAMON COUNTY

SCALE: VERT. _____
 HORIZ. _____
 DATE: MAY 2005

DRAWN BY: KDA
 CHECKED BY: _____

CONTRACT NO. 72A00

F.A. RTE.	SECTION	COUNTY	TOTAL SHEETS	SHEET NO.
	D-6 ITS #1	SANGAMON	36	36
STA.		TO STA.		
FED. ROAD DIST. NO.	ILLINOIS	FED. AID PROJECT		

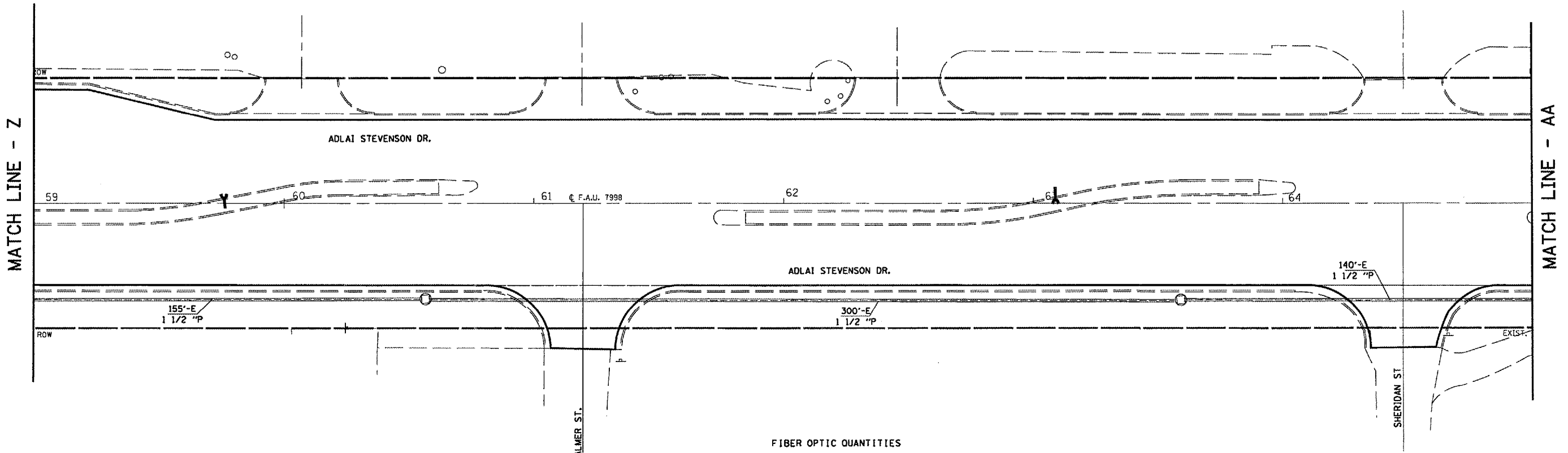

FIBER OPTIC QUANTITIES

QUANTITY	UNIT	ITEM
598.0	FOOT	FIBER OPTIC CABLE IN CONDUIT, NO 62.5/125, 8F

PLOT DATE * DATE *
 FILE NAME * FILE *
 PLOT SCALE * SCALE *
 USER NAME * USER *

REVISIONS	
NAME	DATE

ILLINOIS DEPARTMENT OF TRANSPORTATION
PROPOSED FIBER OPTIC
 STEVENSON DR
 D-6 ITS
 SANGAMON COUNTY
 SCALE: VERT. 1" = 20'
 HORIZ. DATE MAY 2005
 DRAWN BY KDA
 CHECKED BY

F.A. RTE.	SECTION	COUNTY	TOTAL SHEETS	SHEET NO.
	D-6 ITS #1	SANGAMON		37
STA.		TO STA.		
FED. ROAD DIST. NO.	ILLINOIS	FED. AID PROJECT		

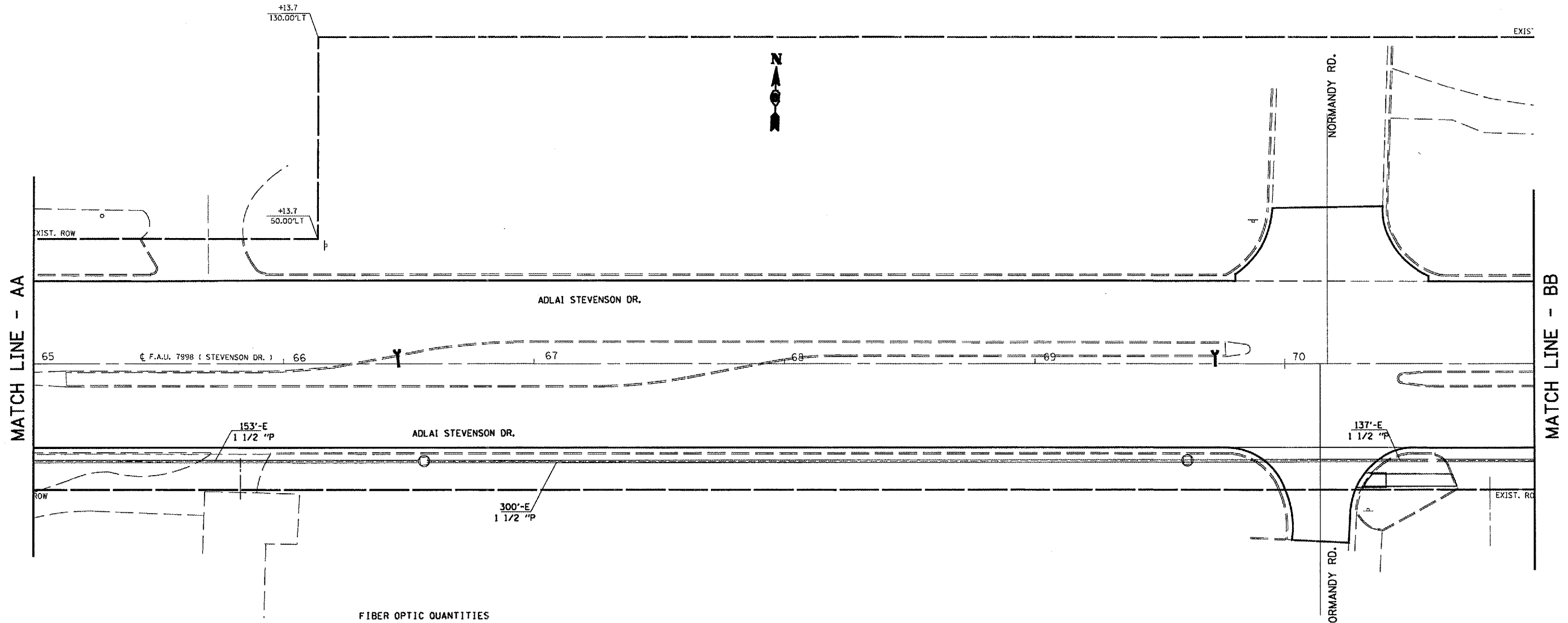

FIBER OPTIC QUANTITIES

QUANTITY	UNIT	ITEM
593.0	FOOT	FIBER OPTIC CABLE IN CONDUIT, NO 62.5/125, 8F

PLOT DATE : 04/27/05
 FILE NAME : 071121A
 PLOT SCALE : 1/8"=1'-0"
 USER NAME : WJG/ENR

REVISIONS	
NAME	DATE

ILLINOIS DEPARTMENT OF TRANSPORTATION
PROPOSED FIBER OPTIC
 STEVENSON DR
 D-6 ITS
 SANGAMON COUNTY

SCALE: VERT. 1" = 20'
 HORIZ. 1" = 40'
 DATE: MAY 2005

DRAWN BY: KDA
 CHECKED BY:

F.A. RTE.	SECTION	COUNTY	TOTAL SHEETS	SHEET NO.
	D-6 ITS #1	SANGAMON		38
STA.		TO STA.		
FED. ROAD DIST. NO.	ILLINOIS	FED. AID PROJECT		

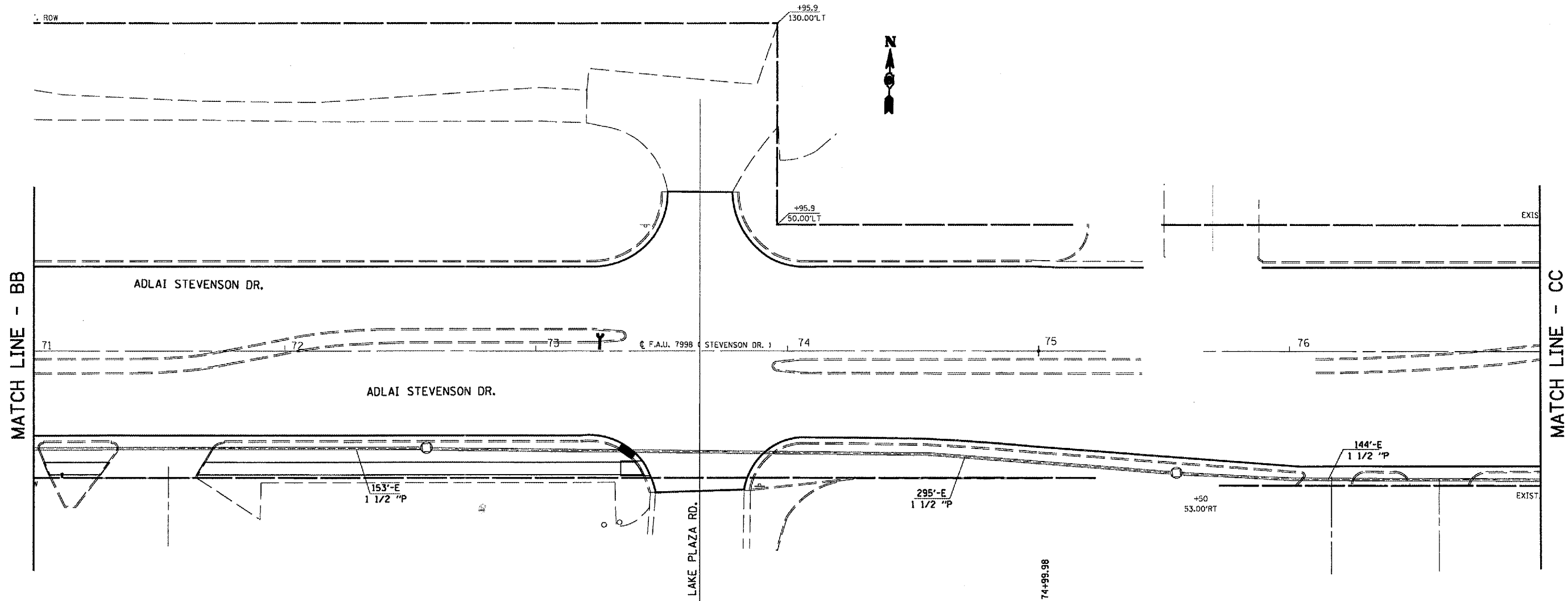

FIBER OPTIC QUANTITIES

QUANTITY	UNIT	ITEM
595.0	FOOT	FIBER OPTIC CABLE IN CONDUIT, NO 62.5/125, 8F

P.O.T. STA. 74+99.98

PLOT DATE: 05/04/05
 FILE NAME: 0511E18
 PLOT SCALE: 1/2000
 USER NAME: KDA

REVISIONS	
NAME	DATE

ILLINOIS DEPARTMENT OF TRANSPORTATION
PROPOSED FIBER OPTIC
 STEVENSON DR
 D-6 ITS
 SANGAMON COUNTY

SCALE: VERT. 1" = 20'
 HORIZ. 1" = 200'
 DATE: MAY 2005

DRAWN BY: KDA
 CHECKED BY:

F.A. RTE.	SECTION	COUNTY	TOTAL SHEETS	SHEET NO.
	D-6 ITS *1	SANGAMON		39
STA.		TO STA.		
FED. ROAD DIST. NO.		ILLINOIS FED. AID PROJECT		

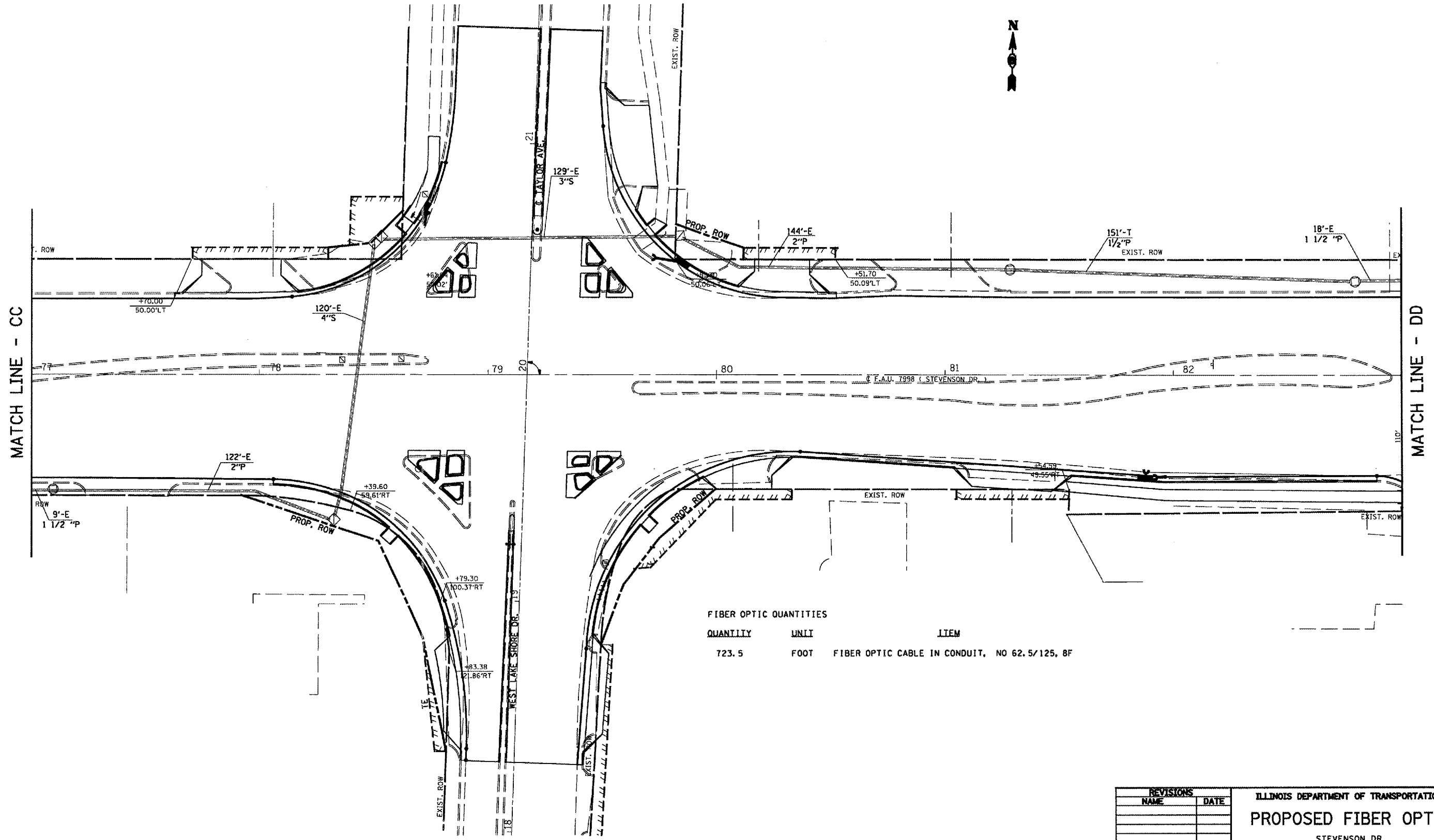

FIBER OPTIC QUANTITIES

QUANTITY	UNIT	ITEM
723.5	FOOT	FIBER OPTIC CABLE IN CONDUIT, NO 62.5/125, 8F

PLOT DATE * DATE *
 FILE NAME * FILE *
 PLOT SCALE * SCALE *
 USER NAME * USER *

REVISIONS	
NAME	DATE

ILLINOIS DEPARTMENT OF TRANSPORTATION
PROPOSED FIBER OPTIC
 STEVENSON DR
 D-6 ITS
 SANGAMON COUNTY

SCALE: VERT. 1" = 20'
 HORIZ. 1" = 20'
 DATE MAY 2005

DRAWN BY KDA
 CHECKED BY

F.A. RTE.	SECTION	COUNTY	TOTAL SHEETS	SHEET NO.
	D-6 (TS #1)	SANGAMON		40
STA.		TO STA.		
FED. ROAD DIST. NO.	ILLINOIS	FED. AID PROJECT		

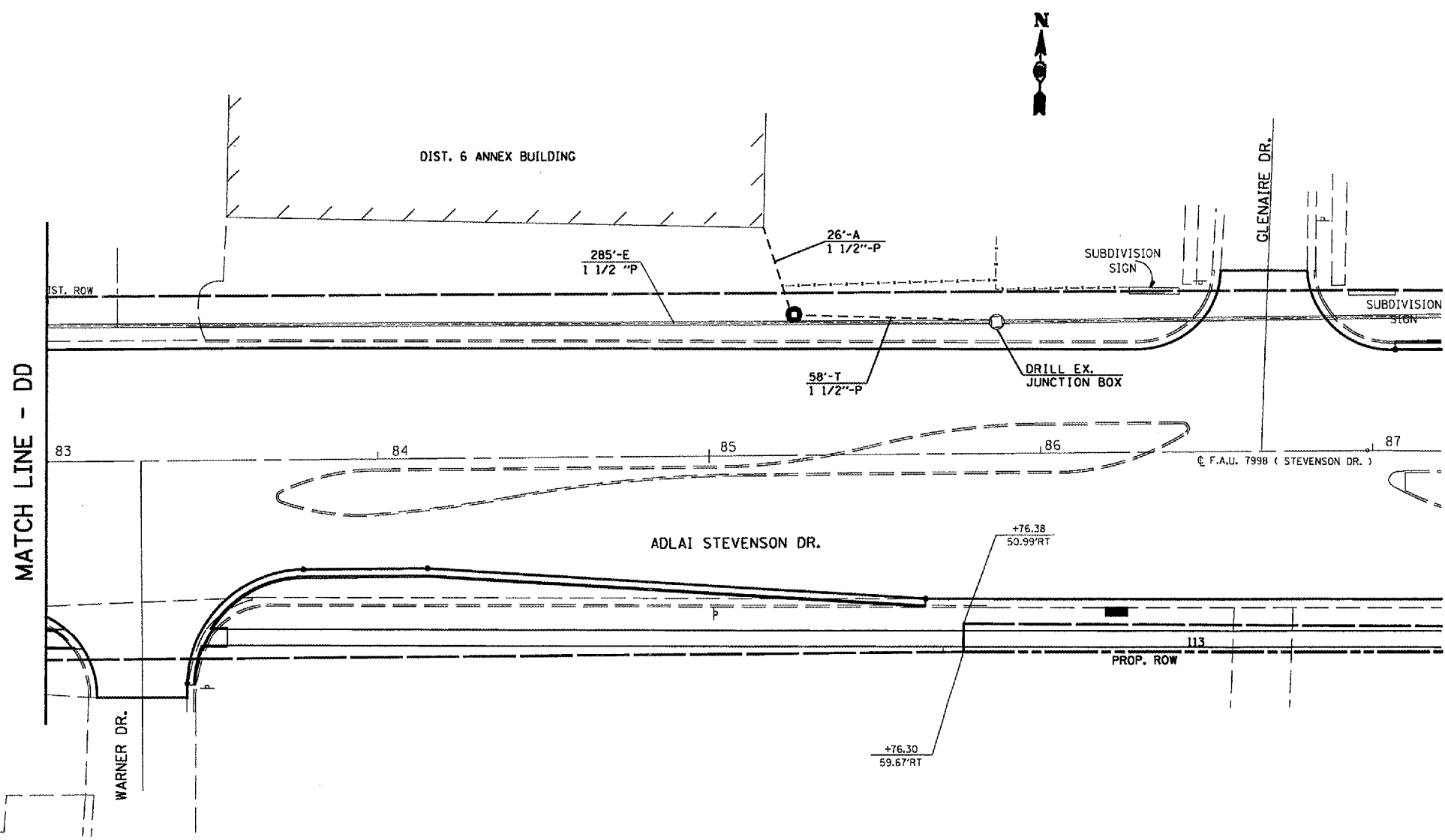

NOTES:

- CONTACT DISTRICT 6 FOR ASSISTANCE IN INSTALLING PROPOSED FIBER OPTIC CABLE TO AND WITHIN DISTRICT 6 ANNEX BUILDING.
- INSTALL 1 1/2" DIA. SCHEDULE 80 PVC CONDUIT ALONG SIDE AND ROOF OF DISTRICT 6 ANNEX BUILDING. CONDUIT SHALL BE MINIMALLY FASTENED TO SIDE OF BUILDING AND ROOF. PAID FOR AS CONDUIT ATTACHED TO STRUCTURE, 1 1/2" DIA., PVC.
- INSTALL PROPOSED FIBER OPTIC CABLE TO DISTRICT 6 ANNEX BUILDING THROUGH PROPOSED PVC CONDUIT. FIBER OPTIC CABLE SHALL BE INSTALLED THROUGH EXISTING WEATHERHEAD ON ROOF. APPROXIMATELY 50' OF FIBER OPTIC CABLE SHALL BE SUSPENDED IN CEILING AND TERMINATED IN PATCH PANEL IN DIST. 6 COMM CENTER. TOTAL LENGTH OF FIBER OPTIC CABLE FROM PROPOSED JUNCTION BOX TO COMMUNICATION CENTER WITHIN DISTRICT 6 OFFICE = 500 FT.

FIBER OPTIC QUANTITIES

QUANTITY	UNIT	ITEM
58.0	FOOT	CONDUIT IN TRENCH, 1 1/2" DIA., PVC
26.0	FOOT	CONDUIT, AUGERED, 1 1/2" DIA., PVC
300.0	FOOT	CONDUIT ATTACHED TO STRUCTURE, 1 1/2" DIA., PVC
1	EACH	JUNCTION BOX (SPECIAL)
1	EACH	DRILL EXISTING JUNCTION BOX
58.0	FOOT	TRENCH AND BACKFILL FOR ELECTRICAL WORK
846.0	FOOT	FIBER OPTIC CABLE IN CONDUIT, NO 62.5/125, 8F

PLOT DATE: * DATE *
 FILE NAME: * #FILE# *
 PLOT SCALE: * #SCALE# *
 USER NAME: * #USER# *

REVISIONS	
NAME	DATE

ILLINOIS DEPARTMENT OF TRANSPORTATION
PROPOSED FIBER OPTIC
 STEVENSON DR
 D-6 ITS
 SANGAMON COUNTY
 SCALE: VERT. 1" = 20'
 HORIZ. 1" = 20'
 DATE: MAY 2005
 DRAWN BY: KDA
 CHECKED BY:

STATE OF ILLINOIS
DEPARTMENT OF TRANSPORTATION

ROUTE NO.	SECTION	COUNTY	SHEETS	SHEET NO.
F.A.I. 55	D-6 ITS #1	SANGAMON	41	SHEETS
FED. ROAD DIST. NO. 7		ILLINOIS	FED. AID PROJECT	

GENERAL NOTES

DESIGN: AASHTO Standard Specifications for Structural Supports for Highway Signs, Luminaires and Traffic Signals. ("AASHTO Specifications")

CONSTRUCTION: Current (at time of letting) Illinois Department of Transportation Standard Specifications for Road and Bridge Construction, Supplemental Specifications and Special Provisions. ("Standard Specifications")

LOADING: 90 M.P.H. WIND VELOCITY

WIND LOADING: 30 p.s.f. normal to Sign Panel Area and Truss elements not behind sign Loading Diagram.

WALKWAY LOADING: Dead load plus 500 lbs. concentrated live load.

DESIGN STRESSES:
Field Units
f_c = 3,500 p.s.i.
f_y = 60,000 p.s.i. (reinforcement)

WELDING: All welds to be continuous unless otherwise shown. All welding to be done in accordance with current AWS D1.1 and D1.2 Structural Welding Codes (Steel and Aluminum) and the Standard Specifications.

MATERIALS: Aluminum Alloys as shown throughout plans. All Structural Steel Pipe shall be ASTM A53 Grade B with a minimum yield of 35,000 p.s.i., or A500 Grade B or C with a minimum yield of 46,000 p.s.i. If A500 pipe is substituted for A53, then the outside diameter shall be as detailed and wall thickness greater than or equal to A53.

All Structural Steel Plates and Shapes shall conform to AASHTO M270 Gr. 36, Gr. 50 or Gr. 50W*. Stainless steel for shims, sleeves and handhole covers shall be ASTM A240, Type 302 or 304, or another alloy suitable for exterior exposure and acceptable to the Engineer. The steel pipe and stiffening ribs at the base plate for the column shall have a minimum longitudinal Charpy V-Notch (CVN) energy of 15 lb.-ft. at 40° F. (Zone 2) before galvanizing.

FASTENERS FOR ALUMINUM TRUSSES: All bolts noted as "high strength" must satisfy the requirements of AASHTO M164 (ASTM A325), or approved alternate, and must have matching lock nuts. Threaded studs for splices (if Members interfere) must satisfy the requirements of ASTM A449, ASTM A193, Grade B7, or approved alternate, and must have matching lock nuts. Bolts and lock nuts not required to be high strength must satisfy the requirements of ASTM A307. All bolts and lock nuts must be hot dip galvanized per AASHTO M232. The lock nuts must have nylon or steel inserts. A stainless steel flat washer conforming to ASTM A240 Type 302 or 304, is required under both head and nut or under both nuts where threaded studs are used. High strength bolt installation shall conform to Article 505.04 (f) (2)d of the IDOT Standard Specifications for Road and Bridge Construction. Rotational capacity ("ROCAP") testing of bolts will not be required.

U-BOLTS AND EYEBOLTS: U-Bolts and Eyebolts must be produced from ASTM A276 Type 304, 304L, 316 or 316L, Condition A, cold finished stainless steel, or an equivalent material acceptable to the Engineer. All nuts for U-Bolts and Eyebolts must be lock nuts equivalent to ASTM A307 with nylon or steel inserts and hot dip galvanized per AASHTO M232. A stainless steel flat washer conforming to ASTM A240, Type 302 or 304, is required under each U-Bolt and Eyebolt lock nut.

GALVANIZING: All Steel Grating, Plates, Shapes and Pipe shall be Hot Dip Galvanized after fabrication in accordance with AASHTO M111. Painting is not permitted.

ANCHOR RODS: Shall conform to AASHTO M314 Gr. 36 or 55 with a minimum Charpy V-Notch (CVN) energy of 15 lb.-ft. at 40° F.

CONCRETE SURFACES: All concrete surfaces above an elevation 6" below the lowest final ground line at each foundation shall be cleaned and coated with Bridge Seat Sealer in accordance with the Standard Specifications.

REINFORCEMENT BARS: Reinforcement Bars designated (E) shall be epoxy coated in accordance with the Standard Specifications.

* If M270 Gr. 50W (M222) steel is proposed, chemistry for plate to be used shall first be approved by the Engineer as suitable for galvanizing and welding.

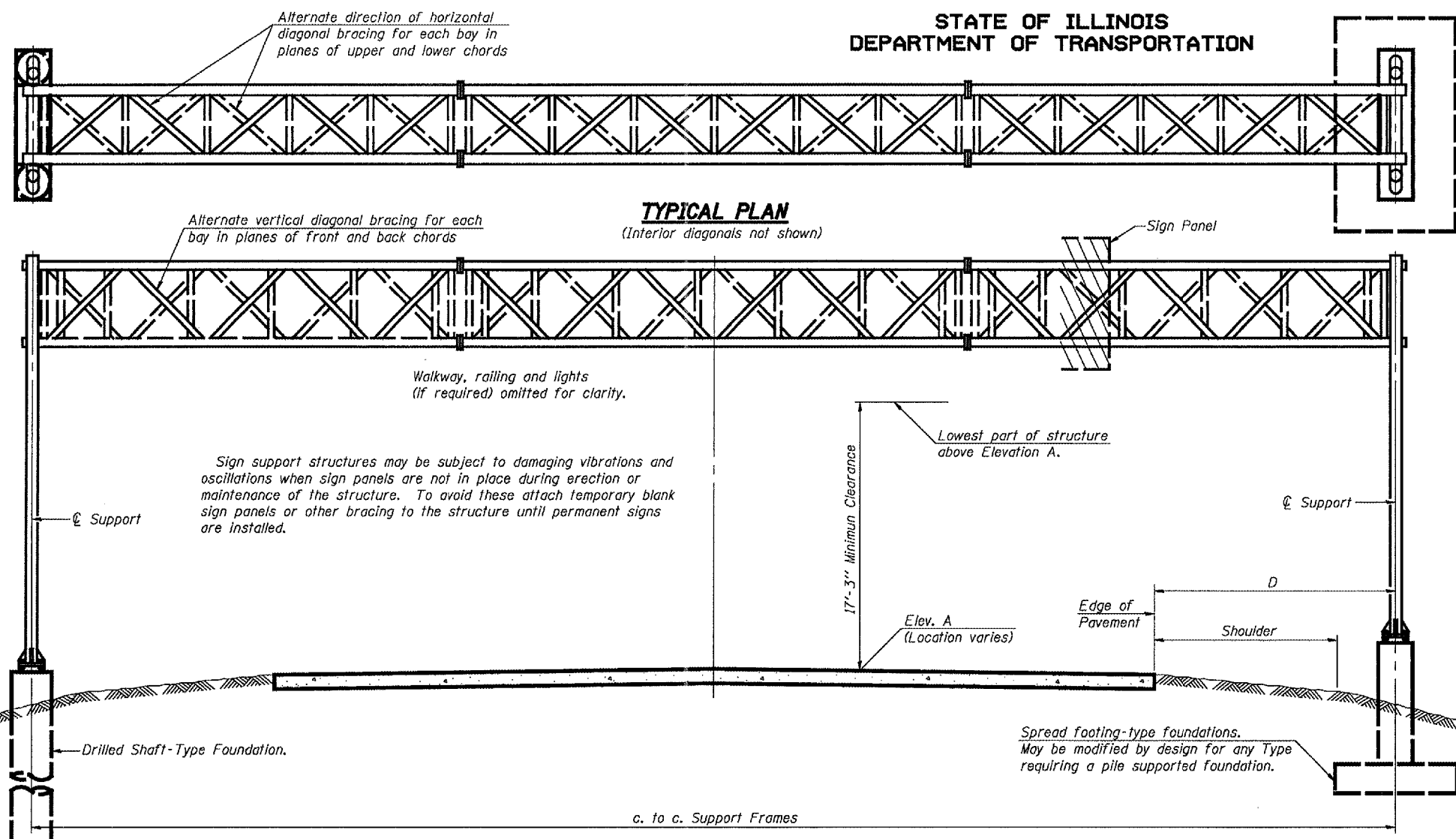

TYPICAL ELEVATION
(Looking at Face of Signs)**)

Elev. A = Elevation at point of minimum clearance to sign, walkway support or truss.

Structure Number	Station	Design Truss Type	c. to c. Supports	Elev. A	Dim. D	Height of Tallest Sign	Total Sign Area
6S0841055R86.9	234+00.00	III-A	110'	599.16	35'-0"		
6S0841055L107.0	202+54.00	III-A	110'	590.50	32'-0"		

**Looking upstation for structures with signs both sides.

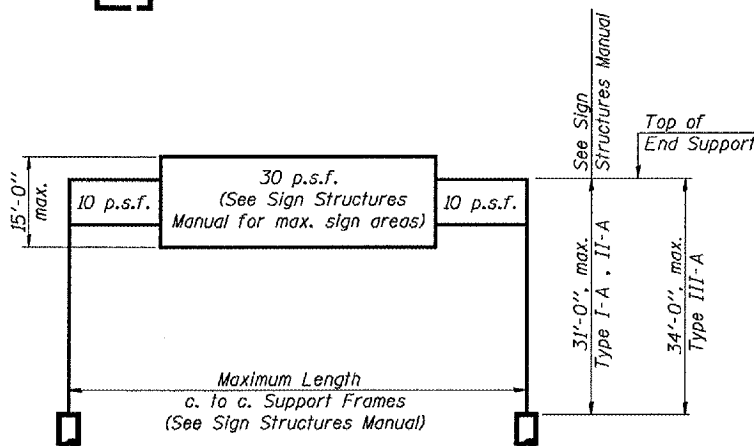

DESIGN WIND LOADING DIAGRAM

Parameters shown are basis for I.D.O.T. Standards and Sign Manual Tables. Installations not within dimensional limits shown require special analysis for all components.

DESIGNED	200
CHECKED	ENGINEER OF BRIDGE DESIGN
DRAWN	ENGINEER OF BRIDGES AND STRUCTURES
CHECKED	

OS-A-1 1-7-05

TOTAL BILL OF MATERIAL

NUMBER	REVISION	DATE

ITEM	UNIT	TOTAL
OVERHEAD SIGN STRUCTURE TYPE I-A (4'-0" x 4'-6")	Foot	
OVERHEAD SIGN STRUCTURE TYPE II-A (4'-6" x 5'-3")	Foot	
OVERHEAD SIGN STRUCTURE TYPE III-A (5'-0" x 7'-0")	Foot	220.0
OVERHEAD SIGN STRUCTURE WALKWAY TYPE A	Foot	21'-6"
CONCRETE FOUNDATIONS	Cu. Yds.	26.0
DRILLED SHAFT CONCRETE FOUNDATIONS	Cu. Yds.	21.2

**OVERHEAD SIGN STRUCTURES
GENERAL PLAN & ELEVATION
ALUMINUM TRUSS & STEEL SUPPORTS**

F.A.I. 55 (I-55)
SECTION D-6 ITS #1
SANGAMON COUNTY

STATE OF ILLINOIS
DEPARTMENT OF TRANSPORTATION

ROUTE NO.	SECTION	COUNTY	SUBS.	SHEET	SHEET NO.
F.A.I. 55	D-6 ITS #1	SANGAMON		42	42
FED. ROAD DIST. NO. 7	BLANKS	FED. AID PROJECT			

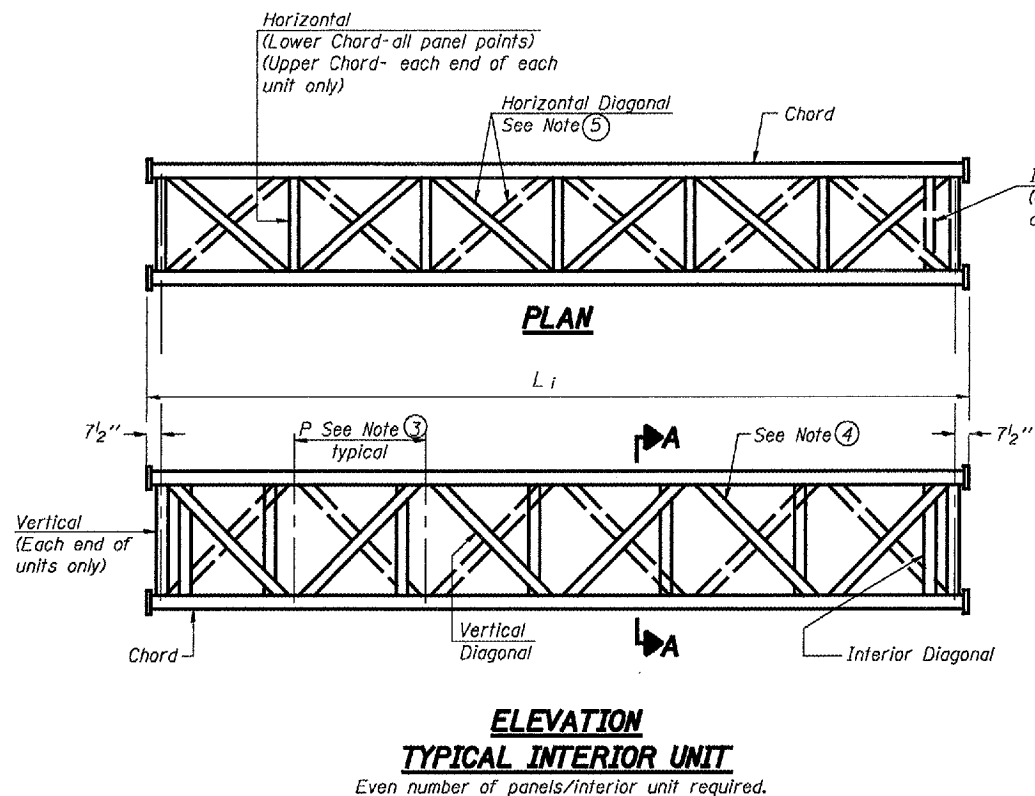

**ELEVATION
TYPICAL INTERIOR UNIT**
Even number of panels/interior unit required.

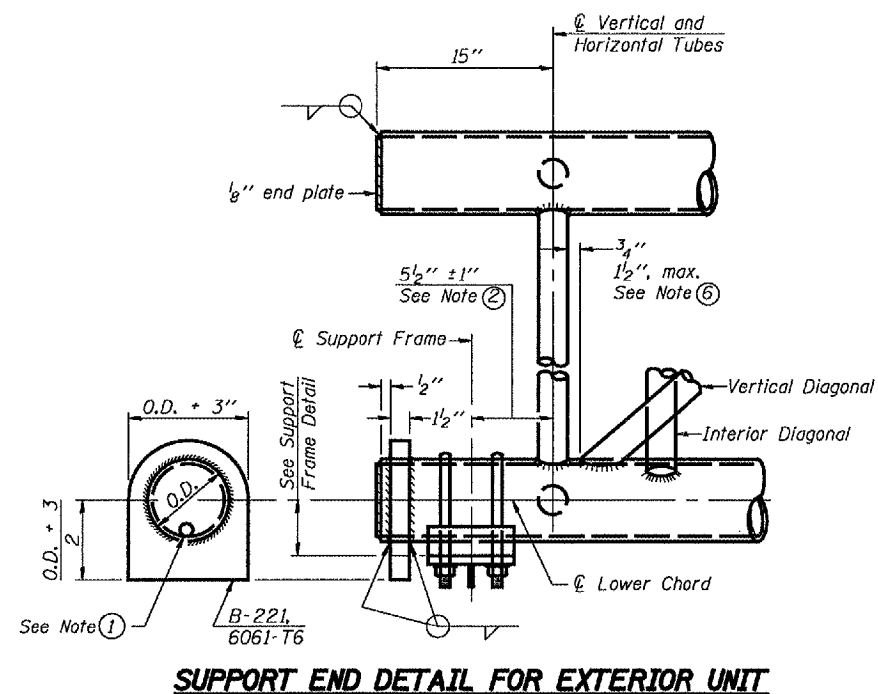

SUPPORT END DETAIL FOR EXTERIOR UNIT

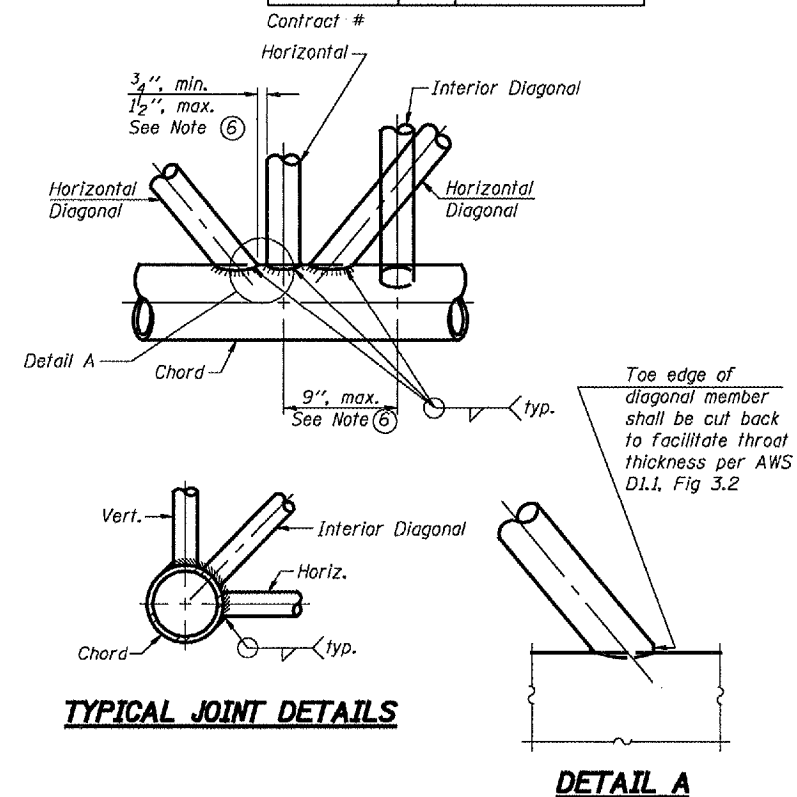

TYPICAL JOINT DETAILS

DETAIL A

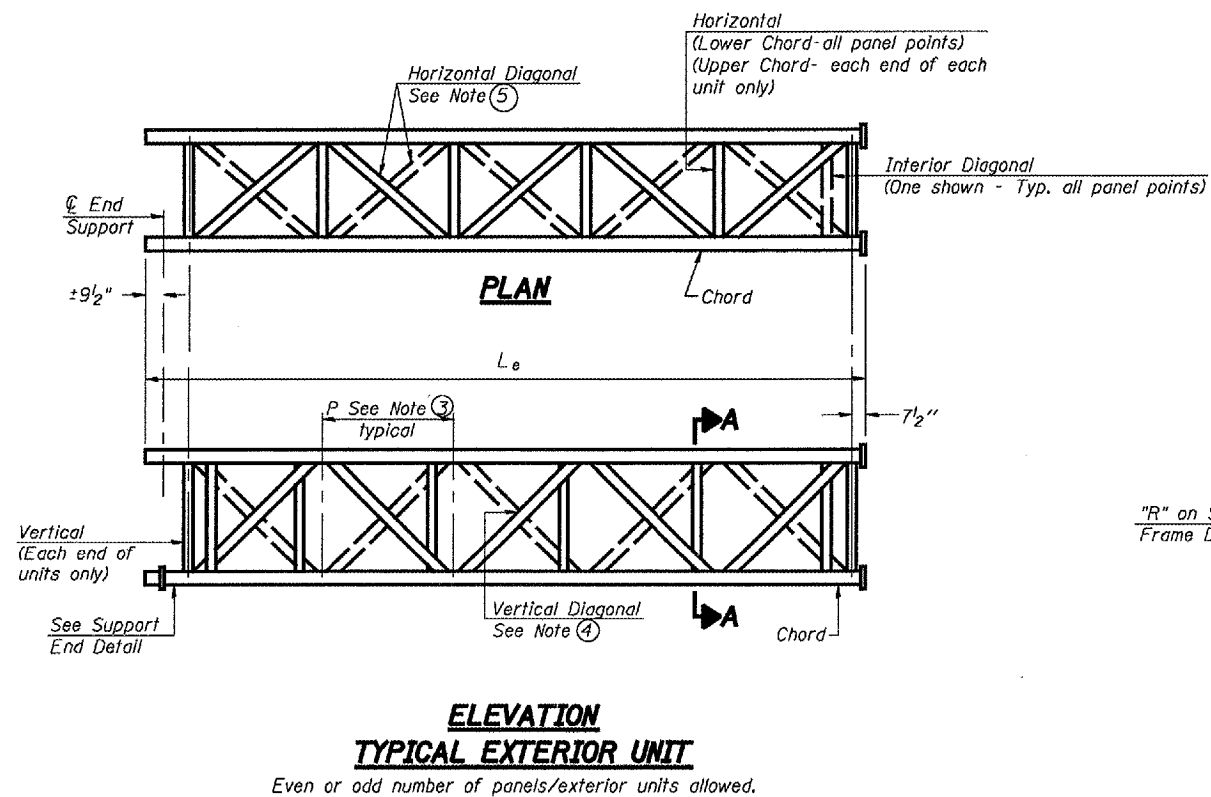

**ELEVATION
TYPICAL EXTERIOR UNIT**
Even or odd number of panels/exterior units allowed.

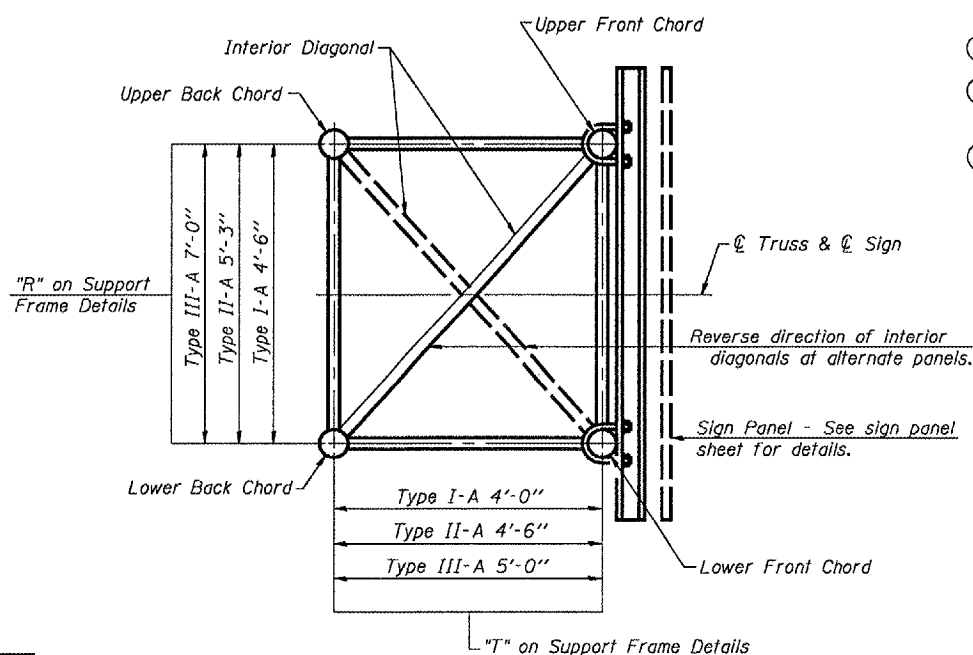

SECTION A-A

- NOTES**
- Contractor may alternatively use standard aluminum drive-fit cap to close end. 1/2" Ø drain hole in end plate/drive-fit cap. (Typ. at ends of all chords)
 - 5 1/2" end dimension may vary by ±1" to provide uniform panel spacing (P).
 - Panel spacing (P) shall be uniform for entire truss and between 4'-0" and 5'-0" for Type I-A or 4'-0" and 5'-6" for Types II-A and III-A.
 - Vertical Diagonals in front and back face shall alternate.
 - Hidden lines show wind bracing alternates direction between planes of top and bottom chords.
 - All diagonals shall be detailed for minimum offset from the panel point based on the following: Offset shall be such as to provide a 3/4" minimum to 1 1/2" maximum clearance between any diagonal and any horizontal or vertical member, and to provide clearance for U-bolt connections of signs or walkway brackets.

**OVERHEAD SIGN STRUCTURES
ALUMINUM TRUSS DETAILS
FOR TRUSS TYPES I-A, II-A and III-A**

F.A.I. 55 (I-55)
SECTION D-6 ITS #1
SANGAMON COUNTY

DESIGNED -	200
CHECKED -	EXAMINED
DRAWN -	ENGINEER OF BRIDGE DESIGN
CHECKED -	PASSED
	ENGINEER OF BRIDGES AND STRUCTURES

NUMBER	REVISION	DATE

STATE OF ILLINOIS
DEPARTMENT OF TRANSPORTATION

ROUTE NO.	SECTION	COUNTY	SHEET NO.	SHEET NO.
F.A.I. 55	D-6 ITS #1	SANGAMON	43	43
FED. ROAD DIST. NO. 7	ILLINOIS	FED. AID PROJECT		

Contract #

TRUSS UNIT TABLE

Structure Number	Station	Design Truss Type	Exterior Units (2)			Interior Unit			Upper & Lower Chord		Verticals; Horizontals; Vertical, Horizontal, and Interior Diagonals				Camber at Midspan	Splicing Flange				
			No. Panels per Unit	Unit Lgth.(L _u)	Panel Lgth.(P)	No. Req'd.	No. Panels per Unit	Unit Lgth.(L _i)	Panel Lgth.(P)	O.D.	Wall	O.D.	Wall	Bolts		Weld Sizes		A	B	
														No./Splice		Dia.	W			W ₁
6S0841055R86.9	234+00.00	III-A	7	39'-2 1/2"	5'-4"	1	6	33'-3"	5'-4"	7"	5/16"	3 1/4"	5/16"	2 13/16"	6	1"	7/16"	5/16"	11 1/2"	15"
6S0841055L107.0	202+54.00	III-A	7	39'-2 1/2"	5'-4"	1	6	33'-3"	5'-4"	7"	5/16"	3 1/4"	5/16"	2 13/16"	6	1"	7/16"	5/16"	11 1/2"	15"

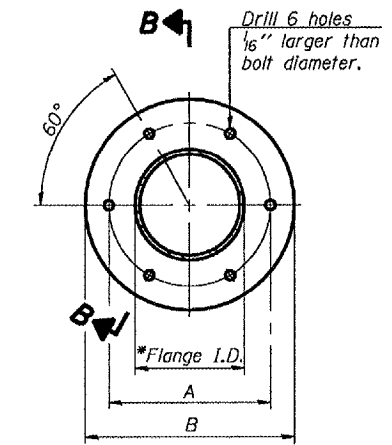

TRUSS TYPES I-A, II-A, & III-A

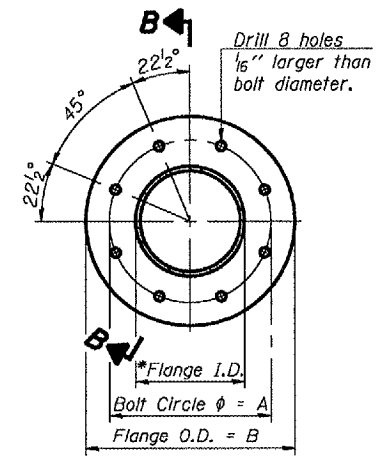

**TRUSS TYPES II-A & III-A
SPlicing FLANGES**

ASTM B221, Alloy 6061-T6
or ASTM B209, Alloy 6061-T651
*To fit O.D. of Chord with maximum gap of 1/16\".

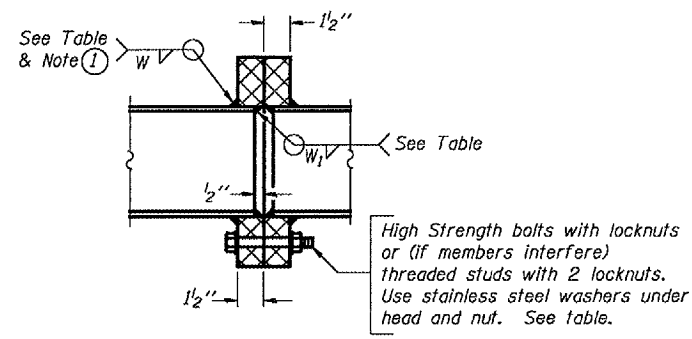

SECTION B-B

① Splicing Flanges shall be attached to each truss unit with the truss shop assembled to camber shown. Truss units shall be in proper alignment and flange surfaces shall be shop bolted into full contact before welding. Sufficient external welds or tacks shall be made to secure flanges until remaining welds are made after disassembly. Adjacent flanges shall be "match marked" to insure proper field assembly.

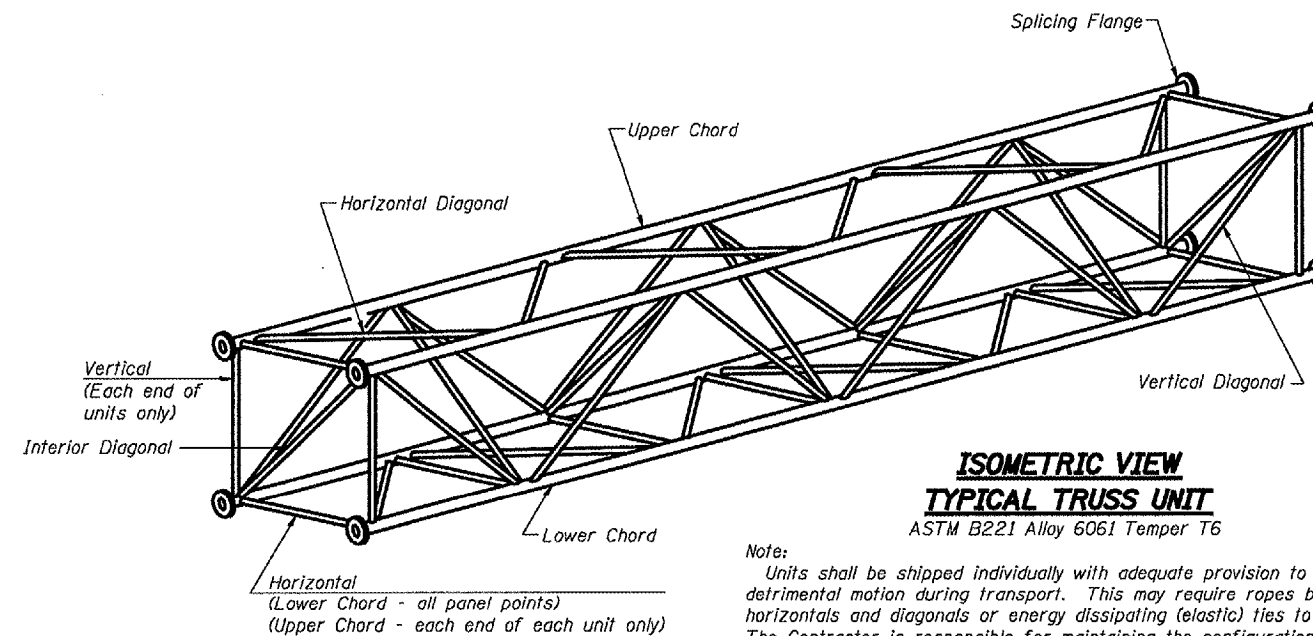

**ISOMETRIC VIEW
TYPICAL TRUSS UNIT**
ASTM B221 Alloy 6061 Temper T6

Note: Units shall be shipped individually with adequate provision to prevent detrimental motion during transport. This may require ropes between horizontals and diagonals or energy dissipating (elastic) ties to the vehicle. The Contractor is responsible for maintaining the configuration and protection of the units.

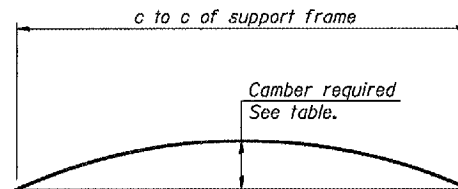

CAMBER DIAGRAM

Camber curve shown is theoretical. Actual camber attained by slope changes at splices between units.

CAMBER ATTAINMENT EXAMPLES:

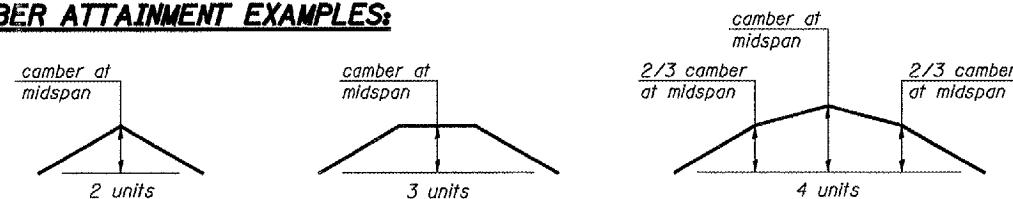

Camber shown is for fabrication only, measured with truss fully supported. (No-load condition)

NUMBER	REVISION	DATE

DESIGNED	200
CHECKED	EXAMINED
DRAWN	ENGINEER OF BRIDGE DESIGN
CHECKED	PASSED
	ENGINEER OF BRIDGES AND STRUCTURES

OS4-A-2

1-7-05

**OVERHEAD SIGN STRUCTURES
ALUMINUM TRUSS DETAILS
FOR TRUSS TYPES I-A, II-A and III-A**

F.A.I. 55 (I-55)
SECTION D-6 ITS #1
SANGAMON COUNTY

STATE OF ILLINOIS
DEPARTMENT OF TRANSPORTATION

* Center of horizontal to center of splice dimension may vary. Verify before drilling holes in mounting tube.

ROUTE NO.	SECTION	COUNTY	SHEET	SET	SHEET NO.
F.A.I. 55	D-6 ITS #1	SANGAMON		AA	
FED. ROAD DIST. NO. 7	ILLINOIS	FED. AID PROJECT			

Contract #

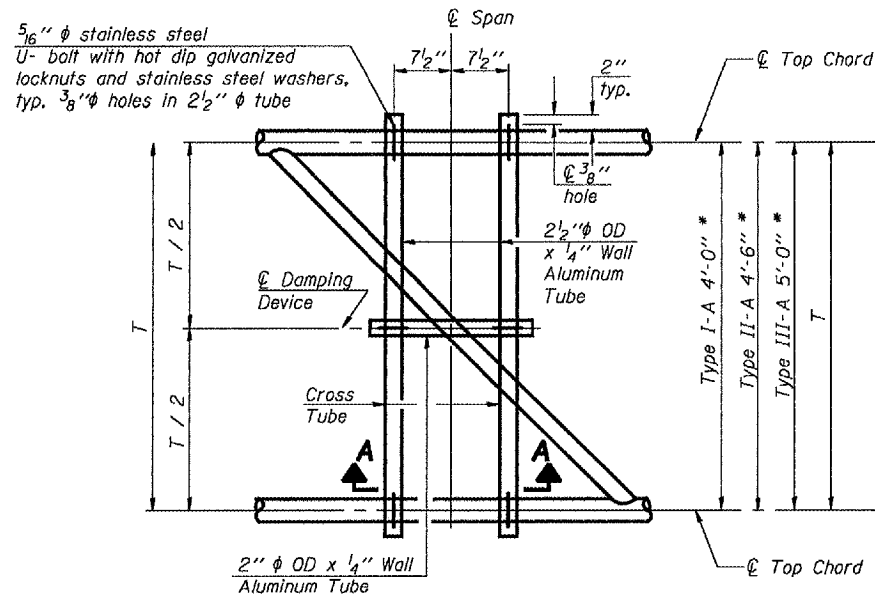

PLAN DETAIL "A"
Span between Panel Points

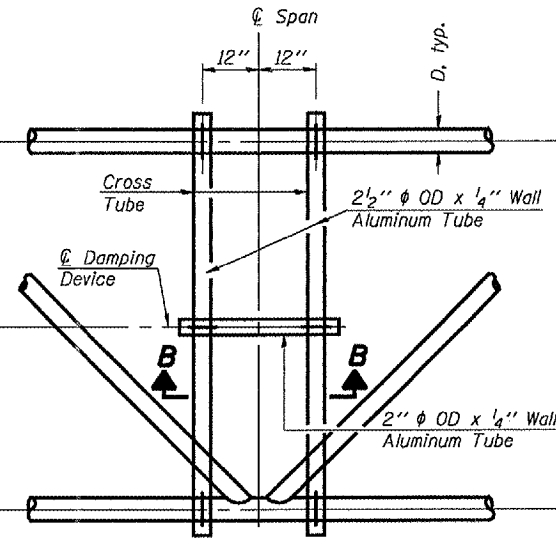

PLAN DETAIL "B"
Span at Panel Point

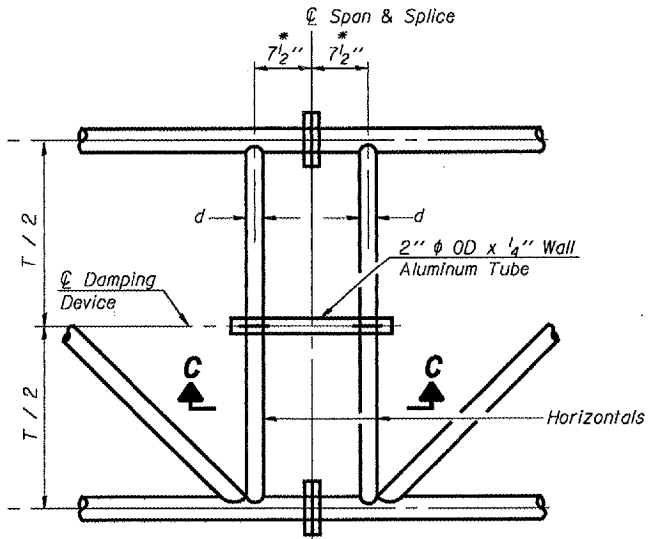

PLAN DETAIL "C"
Span at Chord Splice

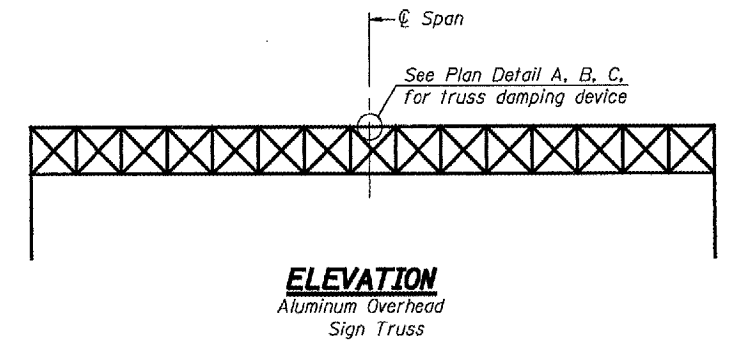

NOTES
Damper: One damper per truss. (31 lbs. Stockbridge-Type Aluminum) Cost included in Overhead Sign Structure...
Materials: Aluminum tubes shall be ASTM B221 alloy 6061 temper T6. Cost included in Overhead Sign Structure...

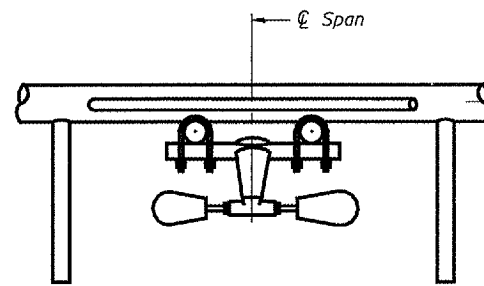

SECTION A-A

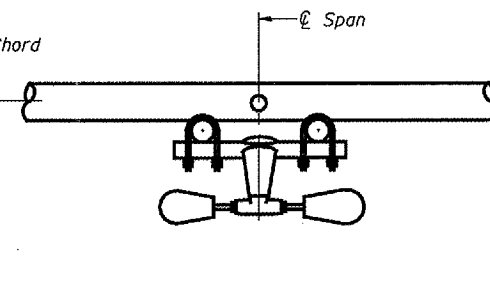

SECTION B-B

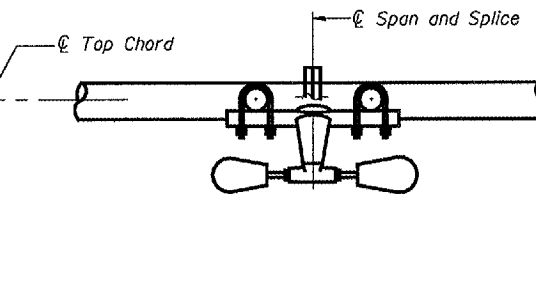

SECTION C-C

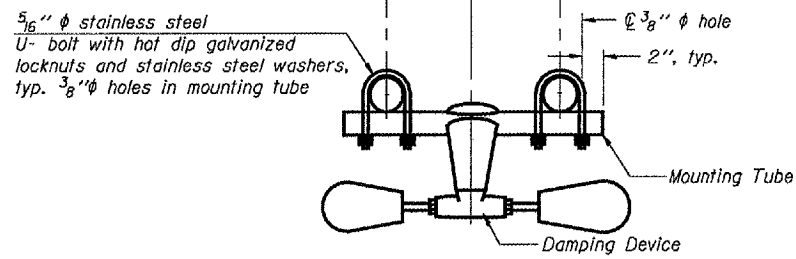

TRUSS DAMPING DEVICE CONNECTION DETAIL
(Typical)

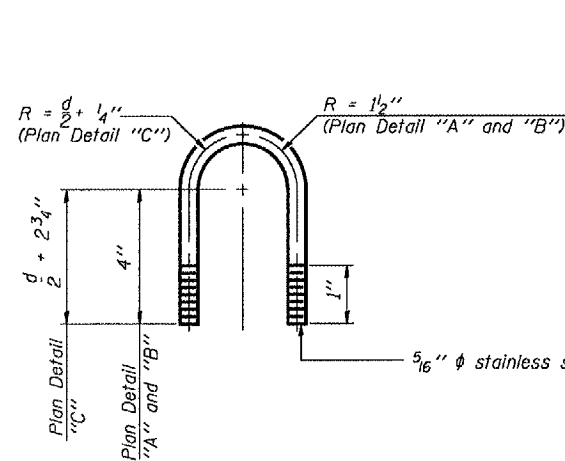

DAMPING DEVICE MOUNTING TUBE U-BOLT DETAIL
(Typical)

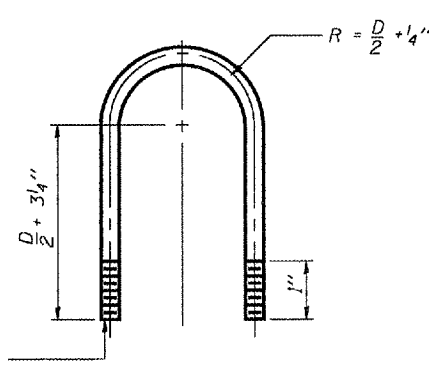

TOP CHORD TO CROSS TUBE U-BOLT DETAIL
(Typical - Detail "A" and "B")

DESIGNED -	200
CHECKED -	EXAMINED
DRAWN -	PASSED
CHECKED -	ENGINEER OF BRIDGES AND STRUCTURES

OS-A-D

1-7-05

OVERHEAD SIGN STRUCTURE DAMPING DEVICE

F.A.I. 55 (I-55)
SECTION D-6 ITS #1
SANGAMON COUNTY

STATE OF ILLINOIS
DEPARTMENT OF TRANSPORTATION

ROUTE NO.	SECTION	COUNTY	ISSUE NO.	SHEET NO.
F.A.I. 55	D-6 ITS #1	SANGAMON		45
FED. ROAD DIST. NO. 7	ILLINOIS	FED. AID PROJECT		SHEETS

Contract #

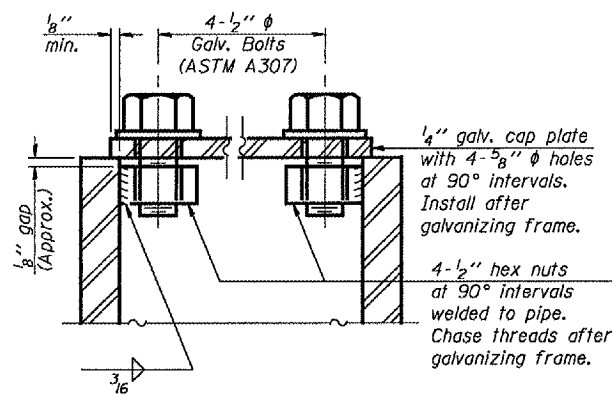
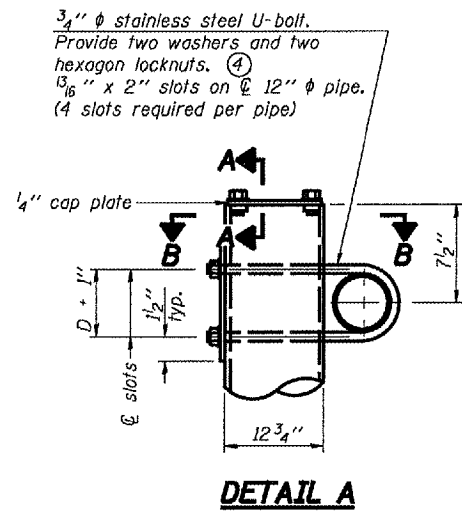

SECTION A-A

As an alternate to bolts, may use galvanized drive-fit caps installed after galvanizing frame.

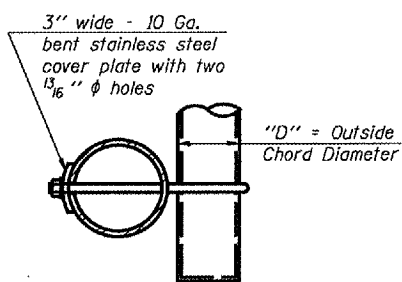

SECTION B-B

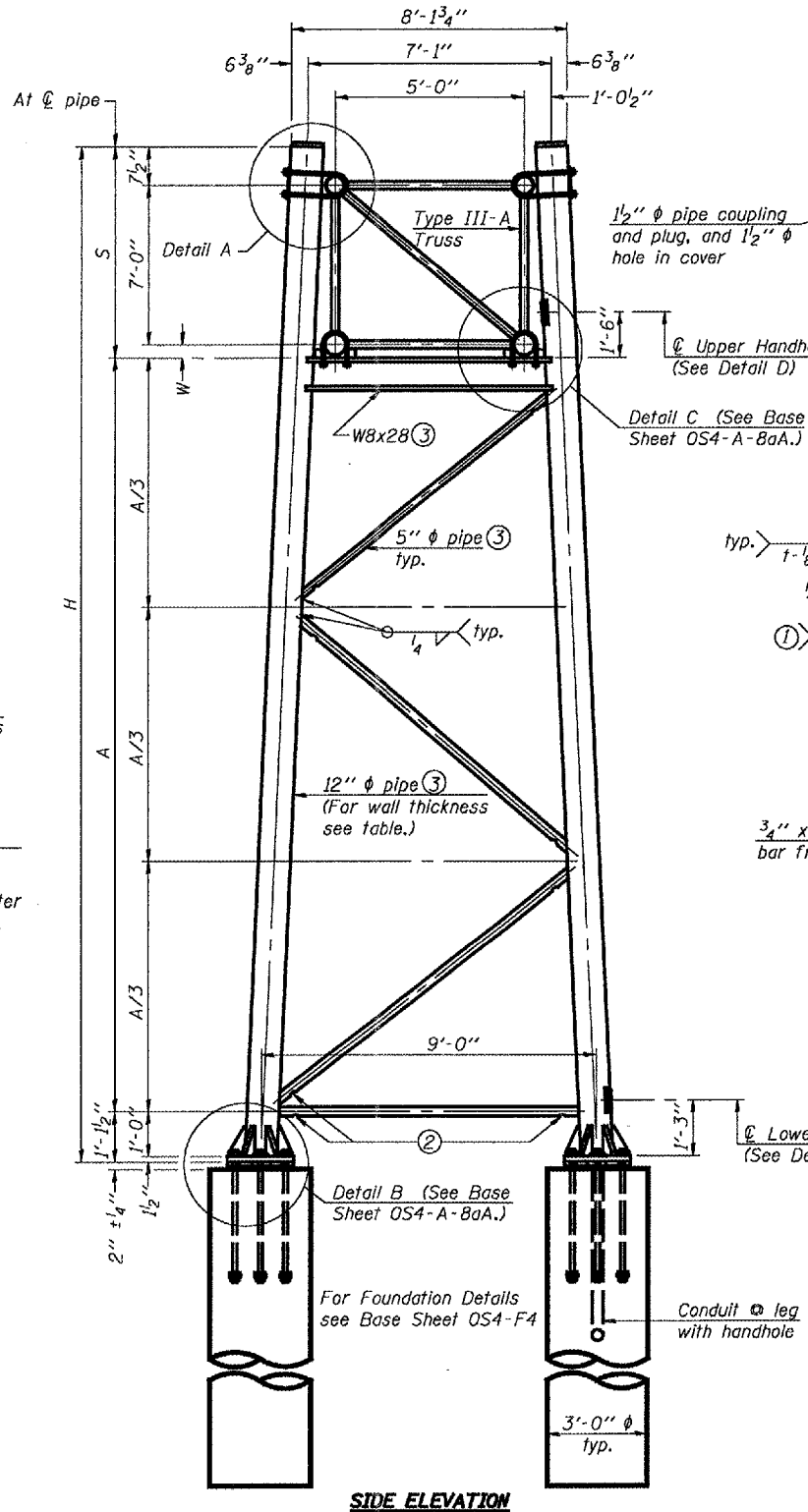

SIDE ELEVATION

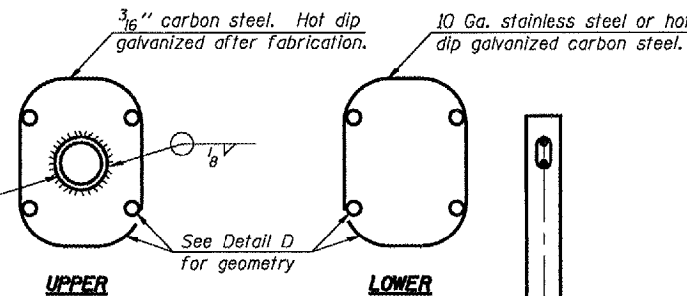

HANDHOLE COVERS

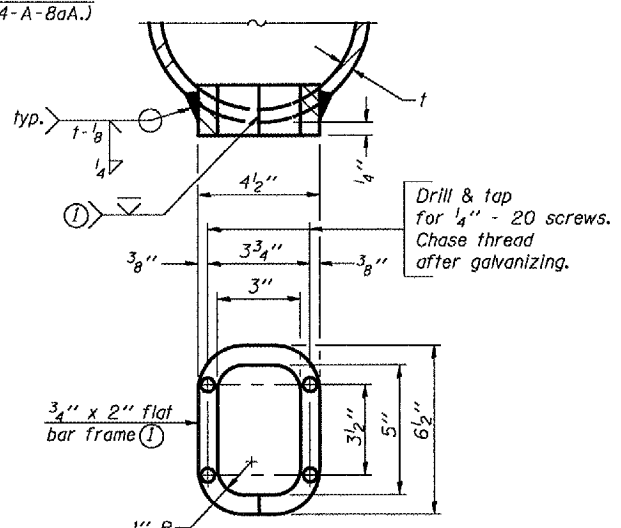

DETAIL D

Provide 6 1/2" x 4 1/2" cover. Provide 4-5/16" diameter holes in cover for 1/4" - 20 round head hot dip galvanized or stainless steel machine screws. (See cover details)

Dimensions		
Truss Chord Nominal Dia.	W	S
7"	4 3/4"	8'-0 1/4"
8 1/2"	5 1/2"	8'-1"
9"	5 3/4"	8'-1 1/4"

TRUSS SUPPORT DETAILS

(12" diameter Pipe - Type III-A Truss)

Support Design Loads: See Base Sheet OS-A-1 for design and loading criteria.
Load combinations checked include deadload plus:
a) 100% wind normal to sign, 20% parallel to sign
b) 60% wind normal to sign, 30% parallel to sign

- In lieu of fabricated handhole frame as shown, may cut from 2" plate (rolling direction vertical). All cut faces to be ground to ANSI Roughness of 500 min or less.
- Galvanizing vent holes of adequate size shall be provided on underside at each end of bracing pipes. Alternately, holes may be provided in wall of pipe column. All vent holes shall be drilled and de-burred, typ.
- Steel pipe, plate, carbon steel handhole covers and rolled sections shall be hot dip galvanized after fabrication. Painting is not permitted. See Base Sheet OS-A-1.
- See General Notes for fasteners.
- Dimensions shown are based on selection criteria in the Sign Structures Manual. Nonstandard applications must have dimensions verified or amended as appropriate.

Structure Number	Station	Support		Pipe Wall Thickness	H	A
		Left	Right			
6S0841055R86.9	234+00.00	X		0.33	28'-2 1/2"	19'-3 1/4"
			X	0.33	27'-4 1/2"	18'-2 3/4"
6S0841055L107.0	202+54.00	X		0.33	26'-1 1/2"	16'-11 3/4"
			X	0.33	25'-2 1/2"	16'-3 1/4"

**OVERHEAD SIGN STRUCTURES
SUPPORT FRAME for TYPE III-A ALUMINUM TRUSS**

F.A.I. 55 (I-55)
SECTION D-6 ITS #1
SANGAMON COUNTY

DESIGNED -	200
CHECKED -	EXAMINED
DRAWN -	PASSED
CHECKED -	ENGINEER OF BRIDGES AND STRUCTURES

NUMBER	REVISION	DATE

STATE OF ILLINOIS
DEPARTMENT OF TRANSPORTATION

ROUTE NO.	SECTION	COUNTY	SHEETS	*SHEET	SHEET NO.
F.A.I. 55	D-6 ITS #1	SANGAMON		46	
FED. ROAD DIST. NO. 7	ILLINOIS	FED. AID PROJECT			

Contract #

Hexagon locknut and washer (top), leveling nut and washer (bottom). Galvanize per AASHTO M232. Nuts shall each be tightened against base plate with 200 lb.-ft. minimum torque.

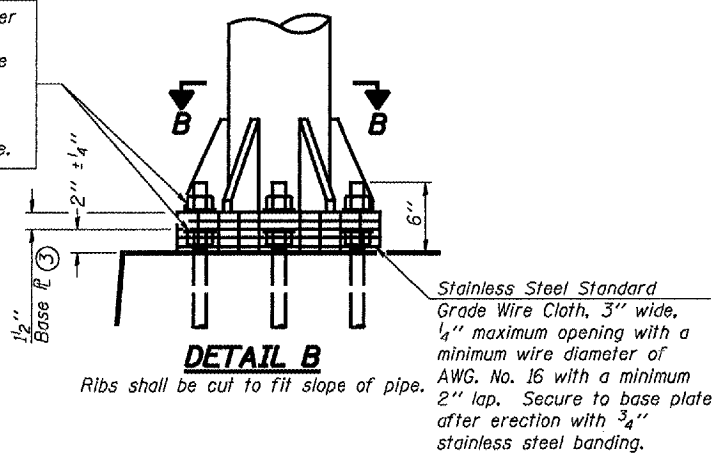

DETAIL B
Ribs shall be cut to fit slope of pipe.

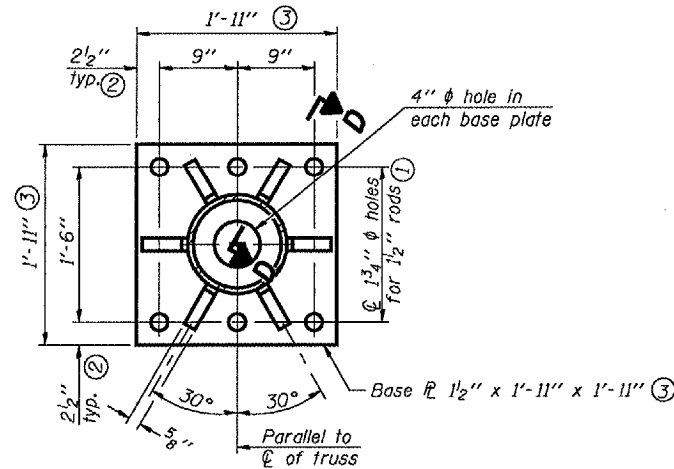

SECTION B-B

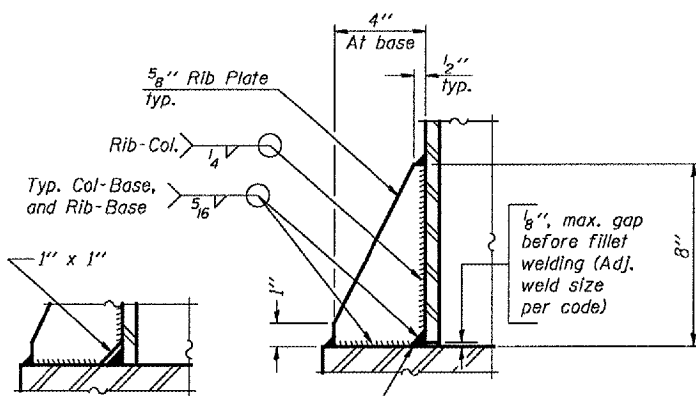

SECTION D-D

** Alternate detail if welding col. to base plate first, then snip inside corner of ribs. Terminate weld on rib 1/4 inch from snip.

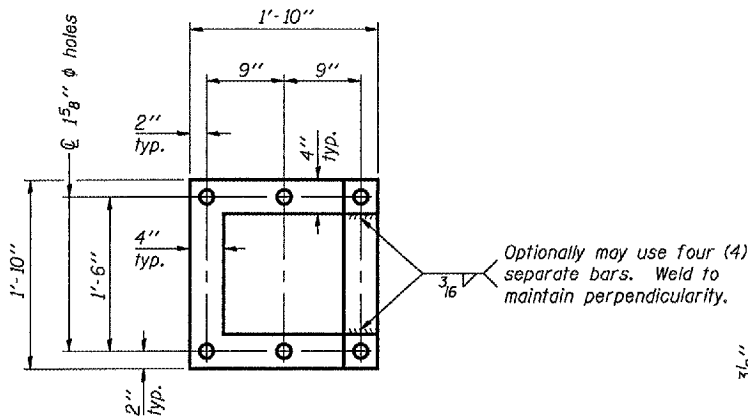

POSITIONING PLATE(S)

At each location, provide 1/4 inch thick positioning plate(s) and six (6) additional nuts to be used with leveling nuts to maintain anchor bolts position during concrete placement.

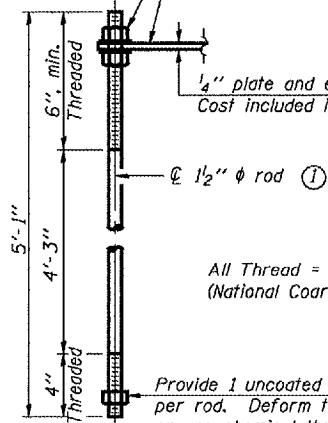

ANCHOR ROD DETAIL

Anchor rods shall conform to AASHTO M314 Grade 36 or 55 and meet Charpy V-Notch (CVN) energy of 15 lb.-ft. at 40° F. Galvanize upper 12 inch per AASHTO M232. No welding shall be permitted on rods.

**TYPE III-A TRUSS
12" PIPE SUPPORT FRAME DETAILS**

Notes:
For Type III-A Truss spans greater than 150 ft. and up to 160 ft.:

- ① 1 3/4 inch rod, 2 inch holes
- ② 2 3/4 inch edge distance
- ③ Base PL 1 5/8 inch x 1-11 1/2 inch x 1-11 1/2 inch

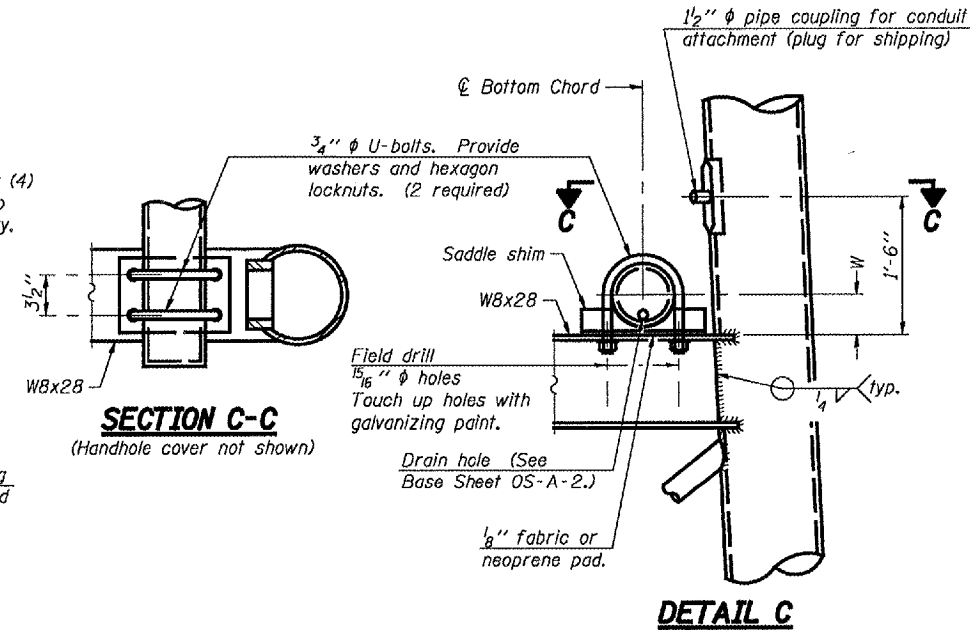

DETAIL C

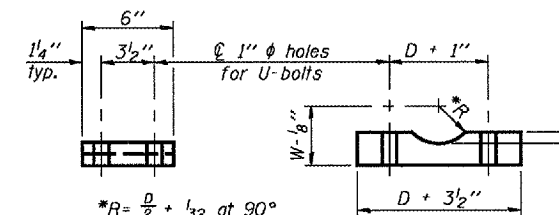

*R = D/2 + 1/32 at 90°
D = Outside Diameter of Chord.
For W, see Base Sheet OS-A-6.

Truss Chord Nominal Dia.	a
7"	1"
8 1/2"	1 1/4"
9"	1 3/8"

SADDLE SHIM DETAIL

ASTM B26 Alloy 356-F
or
ASTM B209 Alloy 6061-T651
(4 required per sign truss)

DESIGNED -	200
CHECKED -	EXAMINED
DRAWN -	ENGINEER OF BRIDGE DESIGN
CHECKED -	PASSED
	ENGINEER OF BRIDGES AND STRUCTURES

1-7-05

NUMBER	REVISION	DATE

OS4-A-8aA

**OVERHEAD SIGN STRUCTURES
SUPPORT FRAME for TYPE III-A ALUMINUM TRUSS**

F.A.I. 55 (I-55)
SECTION D-6 ITS #1
SANGAMON COUNTY

STATE OF ILLINOIS
DEPARTMENT OF TRANSPORTATION

ROUTE NO. F.A.I. 55	SECTION D-6 ITS #1	COUNTY SANGAMON	SHEET NO. 47	SHEET NO. SHEETS
FED. ROAD DIST. NO. 7		ALIGNMENT	FED. AID PROJECT-	

Contract #

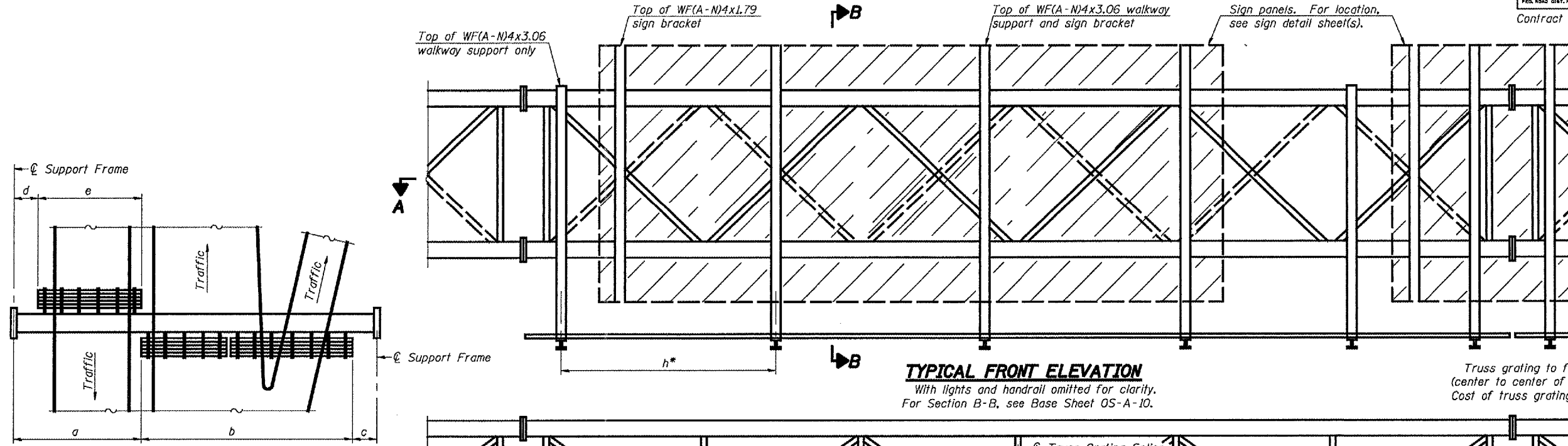

TYPICAL FRONT ELEVATION
With lights and handrail omitted for clarity.
For Section B-B, see Base Sheet OS-A-10.

Truss grating to facilitate inspection shall run full length (center to center of support frames) ±12" on overhead trusses. Cost of truss grating is included in "Overhead Sign Structure".

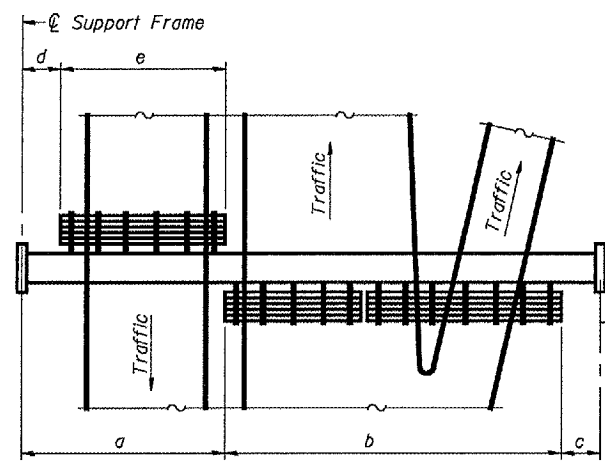

PLAN WALKWAY AND HANDRAIL SKETCH
(Road plan beneath truss varies)

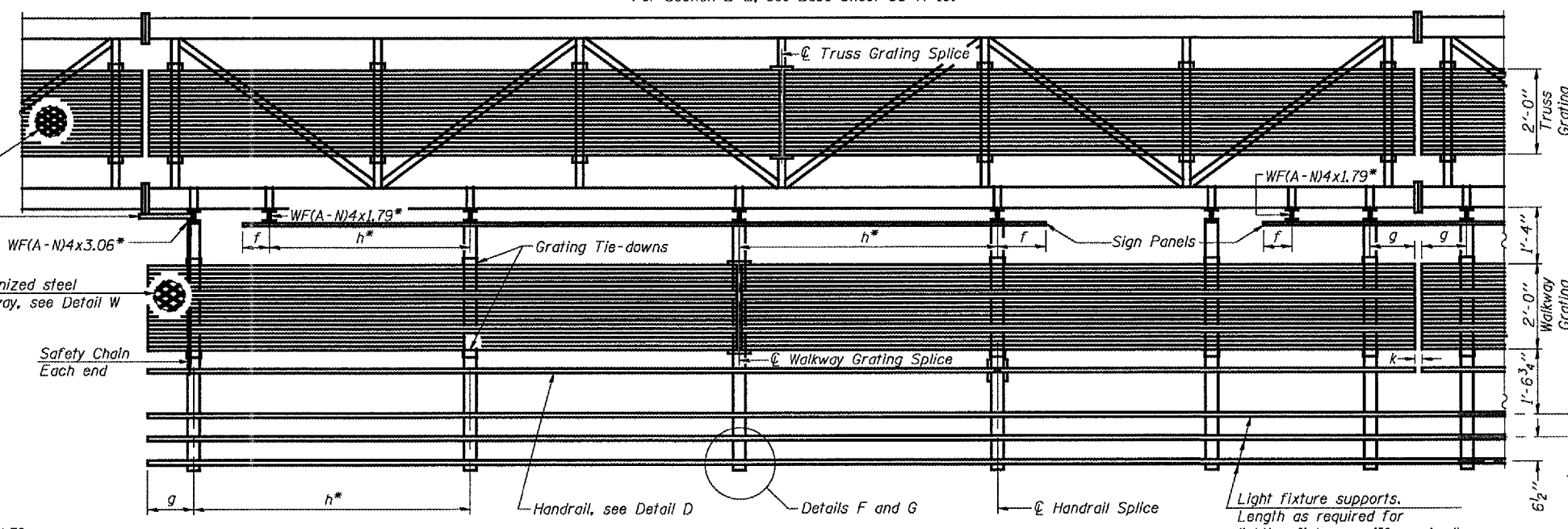

SECTION A-A

Handrail and walkway shall span a minimum of three brackets between splices and/or gap joints. Place all sign and walkway brackets as close to panel points as practical. Grating, handrail and light support splices placed as needed.

Note: Details shown are considered equal alternatives to the Aluminum Walkway on Base Sheet OS-A-9, and may be substituted by Contractor at no change in contract cost.

BRACKET TABLE

Sign Width		Number Brackets Required
Greater Than	Less Than or Equal To	
	8'-0"	2
8'-0"	14'-0"	3
14'-0"	20'-0"	4
20'-0"	26'-0"	5
26'-0"	32'-0"	6

** Alternate angle for safety chain attachment

Walkway and Truss Grating width dimensions are nominal and may vary ±1/2" based on available standard widths.

- Notes:
- * Space walkway brackets WF(A-N)4x3.06 and sign brackets WF(A-N)4x1.79 for efficiency and within limits shown:
 - f = 12" maximum, 4" minimum (End of sign to center of nearest bracket)
 - g = 12" maximum, 4" minimum (End of walkway grating to center of nearest support bracket)
 - h = 6'-0" maximum (center to center of sign and/or walkway support brackets, WF(A-N)4x1.79 or WF(A-N)4x3.06)
 - k = 2" maximum gap between adjacent walkway grating sections and handrail ends
 - ** If walkway bracket at safety chain location is behind sign, add angle to bracket, see Alternate Safety Chain Attachment on Base Sheet OS-A-11.
 - For Details T and W, Section B-B and Grating Splice Details, see Base Sheet OS-A-10.
 - For Details D, F, G and P and Handrail Splice Details, see Base Sheet OS-A-11.

Structure Number	Station	a	b	c	d	e	Walkway Grating and Handrail Lengths
6S0841055R86.9	234+00.00	68'-3"	10'-9"	31'-0"			10'-9"
6S0841055L107.0	202+54.00	71'-3"	10'-9"	28'-0"			10'-9"

**OVERHEAD SIGN STRUCTURES
ALTERNATE WALKWAY DETAILS**

F.A.I. 55 (I-55)
SECTION D-6 ITS #1
SANGAMON COUNTY

DESIGNED -	200
CHECKED -	EXAMINED
DRAWN -	ENGINEER OF BRIDGE DESIGN
CHECKED -	ENGINEER OF BRIDGES AND STRUCTURES

NUMBER	REVISION	DATE

STATE OF ILLINOIS
DEPARTMENT OF TRANSPORTATION

ROUTE NO.	SECTION	COUNTY	TOTAL SHEETS	SHEET NO.	SHEET NO.
F.A.I. 55	D-6 ITS #1	SANGAMON		48	
FED. ROAD DIST. NO. 7	ILLINOIS	FED. AID PROJECT	Contract #		

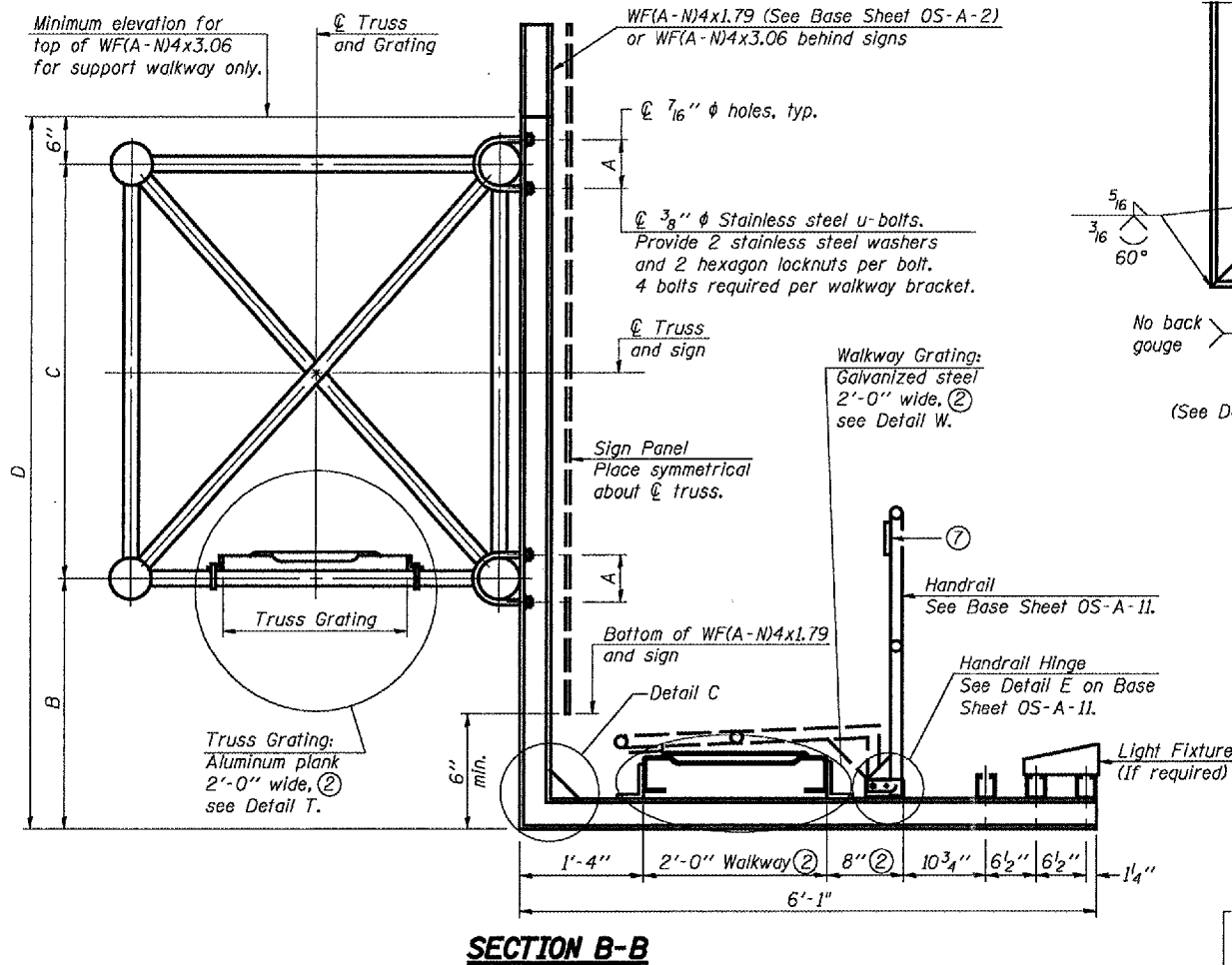

SECTION B-B

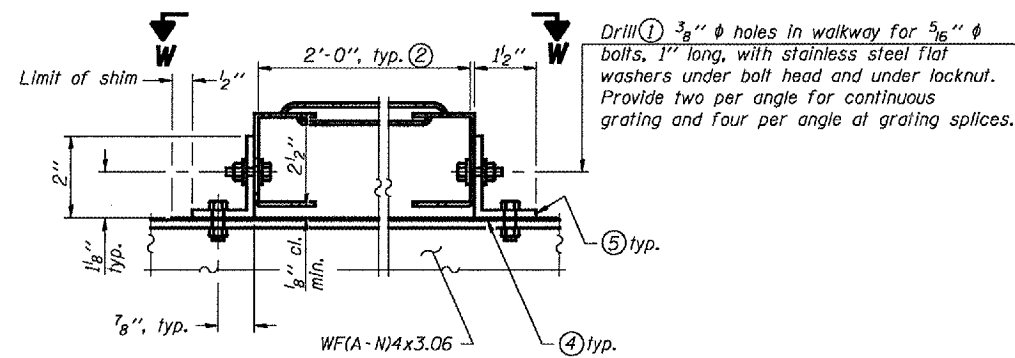

DETAIL W
GALVANIZED STEEL WALKWAY GRATING

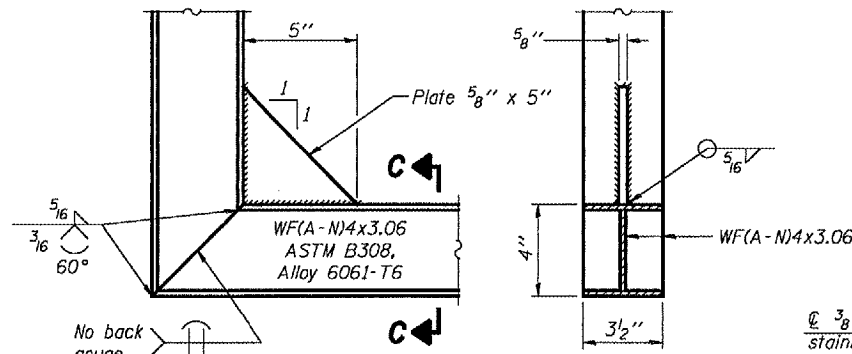

DETAIL C
SECTION C-C

(See Detail P, on Base Sheet OS-A-11.)

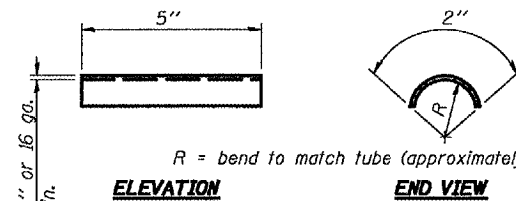

SHIM DETAIL

3/8" phi holes for 5/16" phi steel bolts with two stainless steel washer and hexagon nut per bolt, typ. Provide one per angle at continuous grating or two per angle at grating splices.

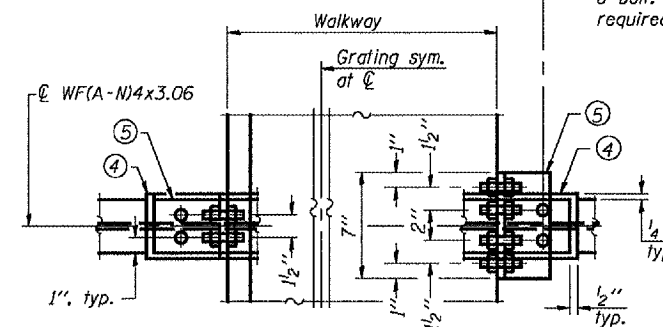

SECTION W-W
WALKWAY GRATING CONTINUOUS AT WALKWAY GRATING SPLICE

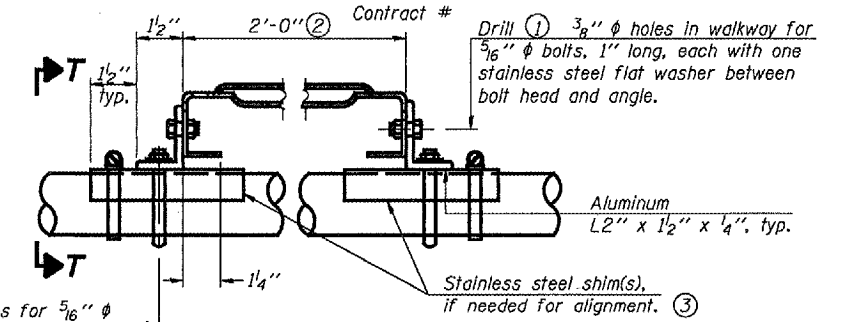

DETAIL T
(Truss grating at horizontal)

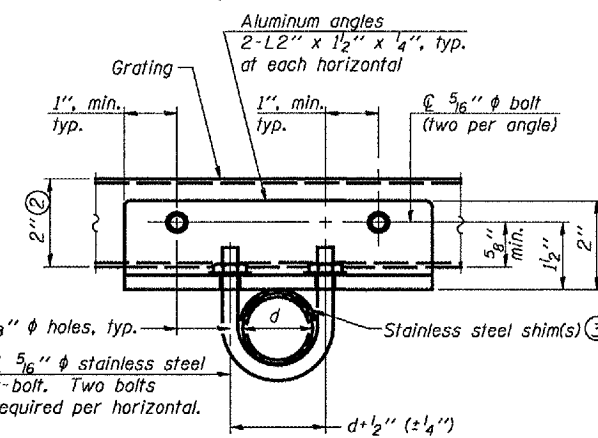

SECTION T-T
(Truss Grating Continuous)

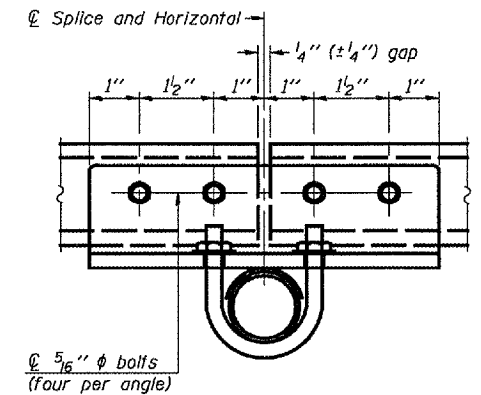

SECTION T-T
(Truss Grating Splice)
Details not shown same as Section T-T. Alternate splice details and locations may be used subject to the Engineer's review and approval.

ALUMINUM TRUSS GRATING

Structure Number	Station	A	B	C	D
650841055R86.9	234+00.00	7 7/16"	1'-3"	7'-0"	8'-9"
650841055L107.0	202+54.00	7 7/16"	1'-3"	7'-0"	8'-9"

- Drilling holes in grating may be done in shop or field, based on Contractor's preference and subject to accurate alignment.
- Perforated or expanded metal grating providing a skid resistant (non-serrated) surface and capable of supporting a 500 pound concentrated load with a 6'-0" clear span. Walkway and truss grating dimensions are nominal and may vary (width ± 1/2", depth ± 1/2") based on available standard sizes. Cut ends of grating shall be free of burrs or hazardous projections and coated with zinc-rich primer or equivalent.
- Stainless steel shims shall be placed under angles at horizontals and horizontal diagonals if needed to compensate for alignment variations and differences in horizontal diagonal pipe sizes beyond adjustment provided by angles. Secure with one stainless steel clamp per location, see "Shim Detail". Thicker shim plates may be used when needed subject to shims performing properly.
- 1/16" (or 16 ga.) x 2 1/2" x 4" stainless steel shim adhered to top of WF(A-N)4x3.06 beneath each galvanized angle. Adhesives for shims shall be suitable for materials joined and full exposure conditions.
- Galvanized steel L2" x 1 1/2" x 1/4", 3 1/2" long with continuous grating, 7 1/2" long at grating splice.
- Details shown are considered equal alternatives to the Aluminum Walkway on Base Sheet OS-A-10 and may be substituted by Contractor at no change in contract cost.
- 1/8" x 1/2" x 2" welded to handrail posts to protect locations that contact grating.

OVERHEAD SIGN STRUCTURES
ALTERNATE WALKWAY DETAILS

F.A.I. 55 (I-55)
SECTION D-6 ITS #1
SANGAMON COUNTY

DESIGNED	200
CHECKED	ENGINEER OF BRIDGE DESIGN
DRAWN	ENGINEER OF BRIDGES AND STRUCTURES
CHECKED	

NUMBER	REVISION	DATE

STATE OF ILLINOIS
DEPARTMENT OF TRANSPORTATION

ROUTE NO.	SECTION	COUNTY	TOTAL SHEETS	SHEET NO.
F.A.I. 55	D-6 ITS #1	SANGAMON	49	49
FED. ROAD DIST. NO. 7	ILLINOIS	FED. AID PROJECT		SHEETS

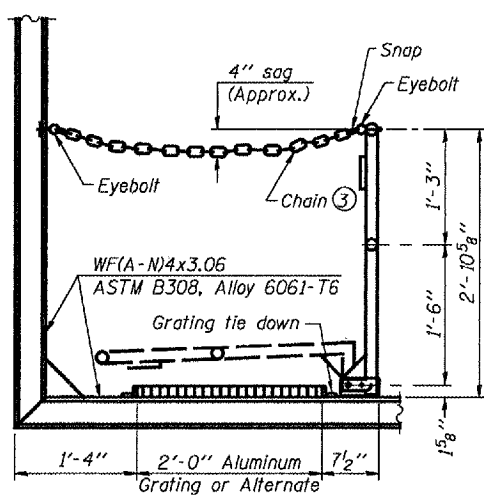

SIDE ELEVATION
(Showing safety chain w/o sign)

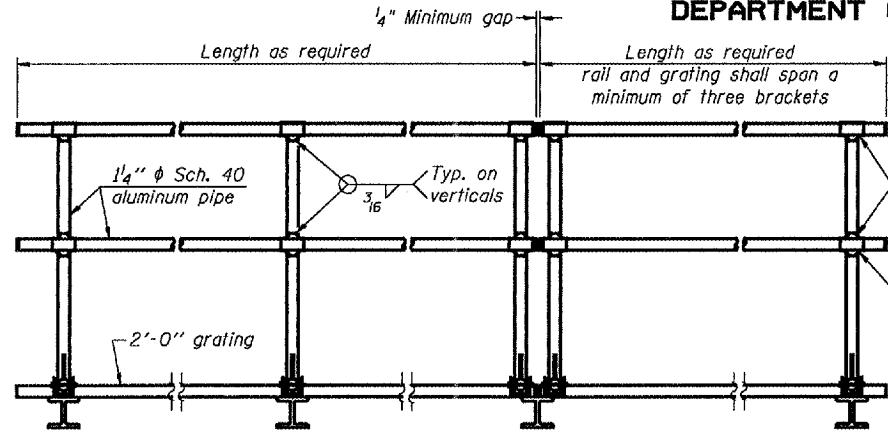

FRONT ELEVATION

HANDRAIL DETAILS

Handrail pipe shall be ASTM B241, Alloy 6063-T6 or Alloy 6061-T6.

- Install standard force-fit end caps or weld 1/8" end plates with 1/8" c.f.w. and grind smooth. (All rail ends)
- Horizontal handrail member shall be continuous thru fitting. Provide 1/16" φ hole in fitting for 3/8" φ bolt. Field drill 1/16" φ hole in horizontal rail member. Provide locknut and two stainless steel washers for bolt. (Use 5/16" eyebolts in 7/16" φ holes on top rail at ends only.)

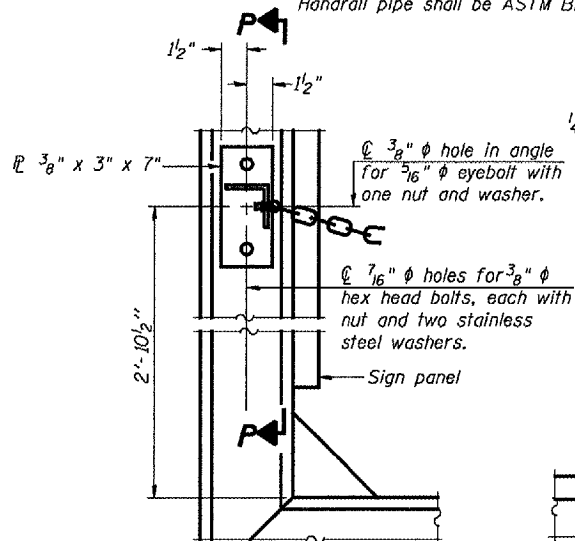
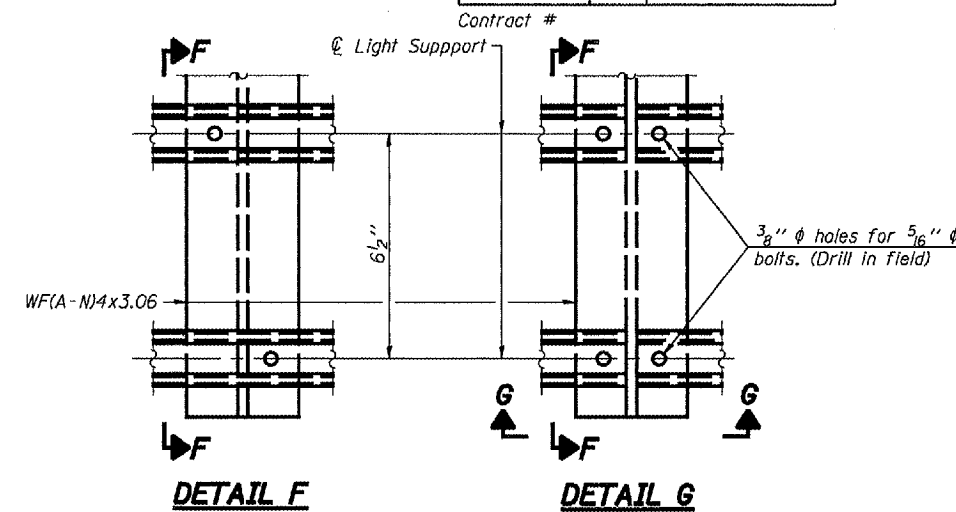

ALTERNATE SAFETY CHAIN ATTACHMENT

(With Sign Present)
Items not shown same as "Side Elevation" of "Handrail Details"

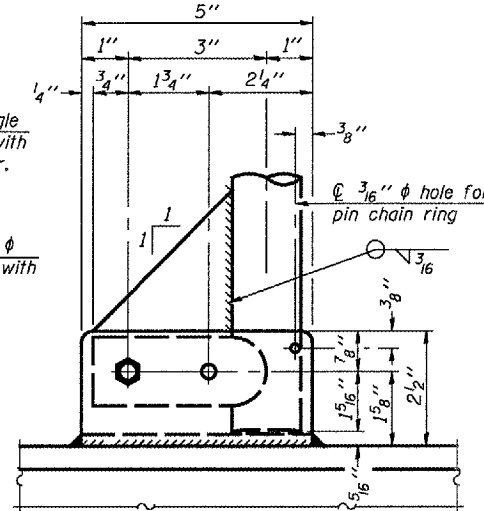

SIDE ELEVATION

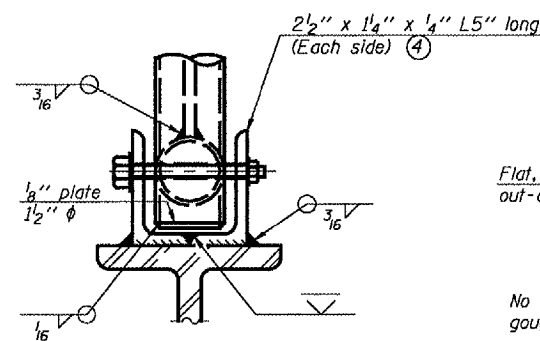

FRONT ELEVATION

See "Elevation" at right for dimensions.

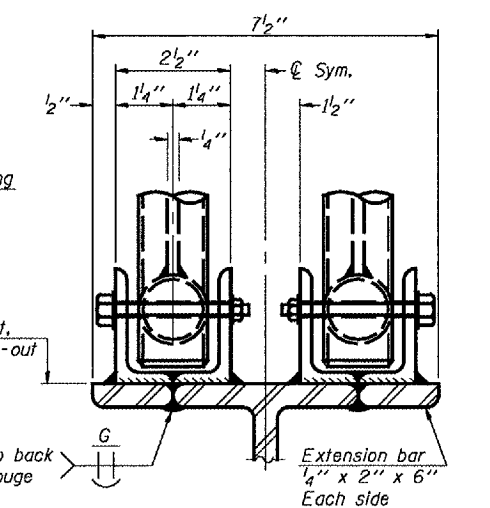

ELEVATION AT HANDRAIL JOINT ④

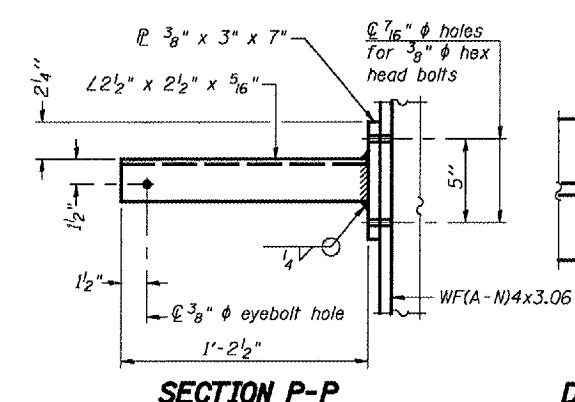

SECTION P-P

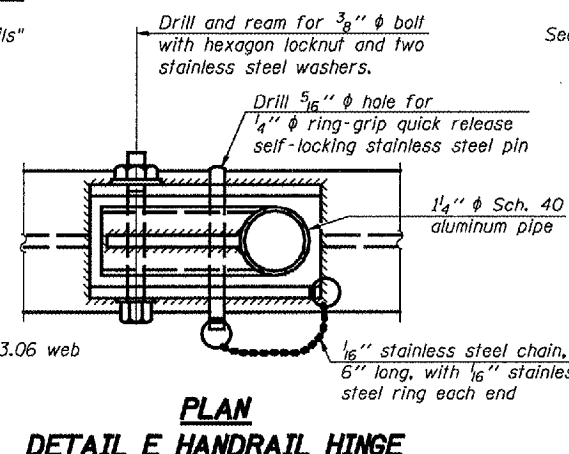

DETAIL E HANDRAIL HINGE

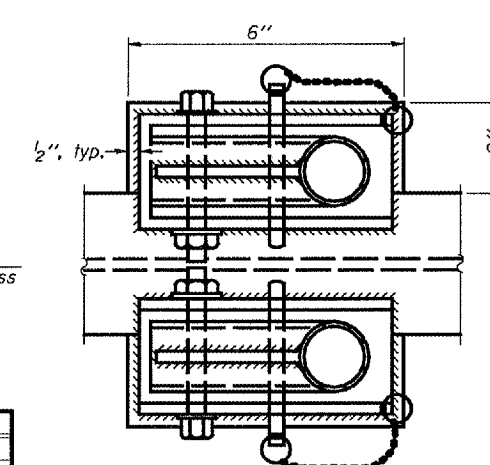

PLAN AT HANDRAIL JOINT

Details not shown same as "PLAN"

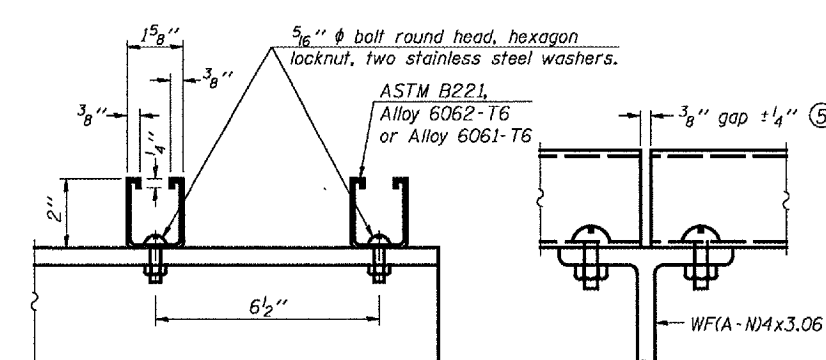

SECTION F-F and SECTION G-G

LIGHTING FIXTURE MOUNTS (IF REQUIRED)

⑤ Field cut ends of light support channels shall be free of burrs or hazardous projections and coated with zinc-rich primer or equivalent.

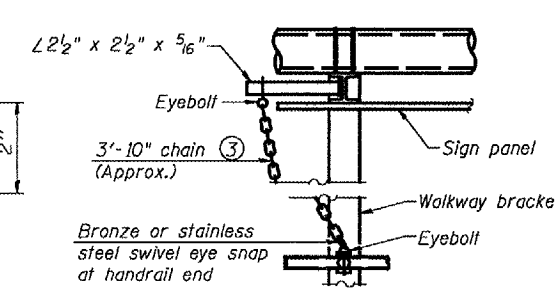

ALTERNATE SAFETY CHAIN ATTACHMENT

Details not shown similar to "Safety Chain" Details (Walkway omitted for clarity)

- 3/16" galvanized steel chain, approximately 12 links per foot. Chain to be hot dip galvanized after manufacture and suitable for prolonged exterior exposure. Alternate materials may be substituted with the Engineer's approval.
- Extrusions may be used in lieu of the details shown, with approval of the Engineer.

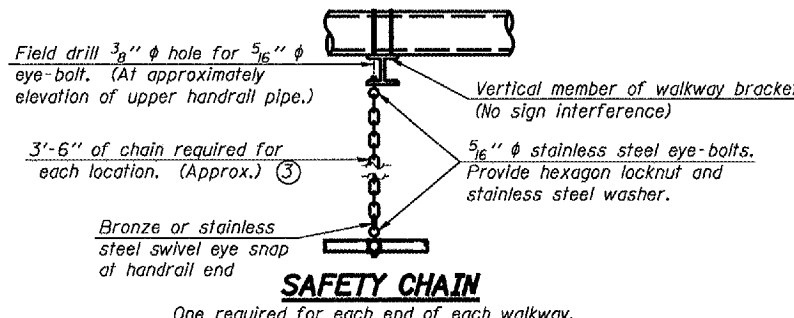

**OVERHEAD SIGN STRUCTURES
ALUMINUM HANDRAIL DETAILS**

F.A.I. 55 (I-55)
SECTION D-6 ITS #1
SANGAMON COUNTY

DESIGNED	200
CHECKED	EXAMINED
DRAWN	PASSED
CHECKED	ENGINEER OF BRIDGE DESIGN
	ENGINEER OF BRIDGES AND STRUCTURES

NUMBER	REVISION	DATE

STATE OF ILLINOIS
DEPARTMENT OF TRANSPORTATION

ROUTE NO.	SECTION	COUNTY	TOTAL SHEETS	SHEET NO.
F.A.I. 55	D-6 ITS #1	SANGAMON	50	50
FED. ROAD DIST. NO. 2	ILLINOIS	FED. AID PROJECT		

Contract #

For anchor rod size and placement, see Support Frame Detail Sheet.

* Anchor rod shall be ground or filed to bright metal at clamp and cable connection location.

BAR LIST - EACH FOUNDATION

Bar	Number	Size	Length	Shape
v ₄ (E)	24	#9	F less 5"	—
#4 bar spiral (E) - see Side Elevation				

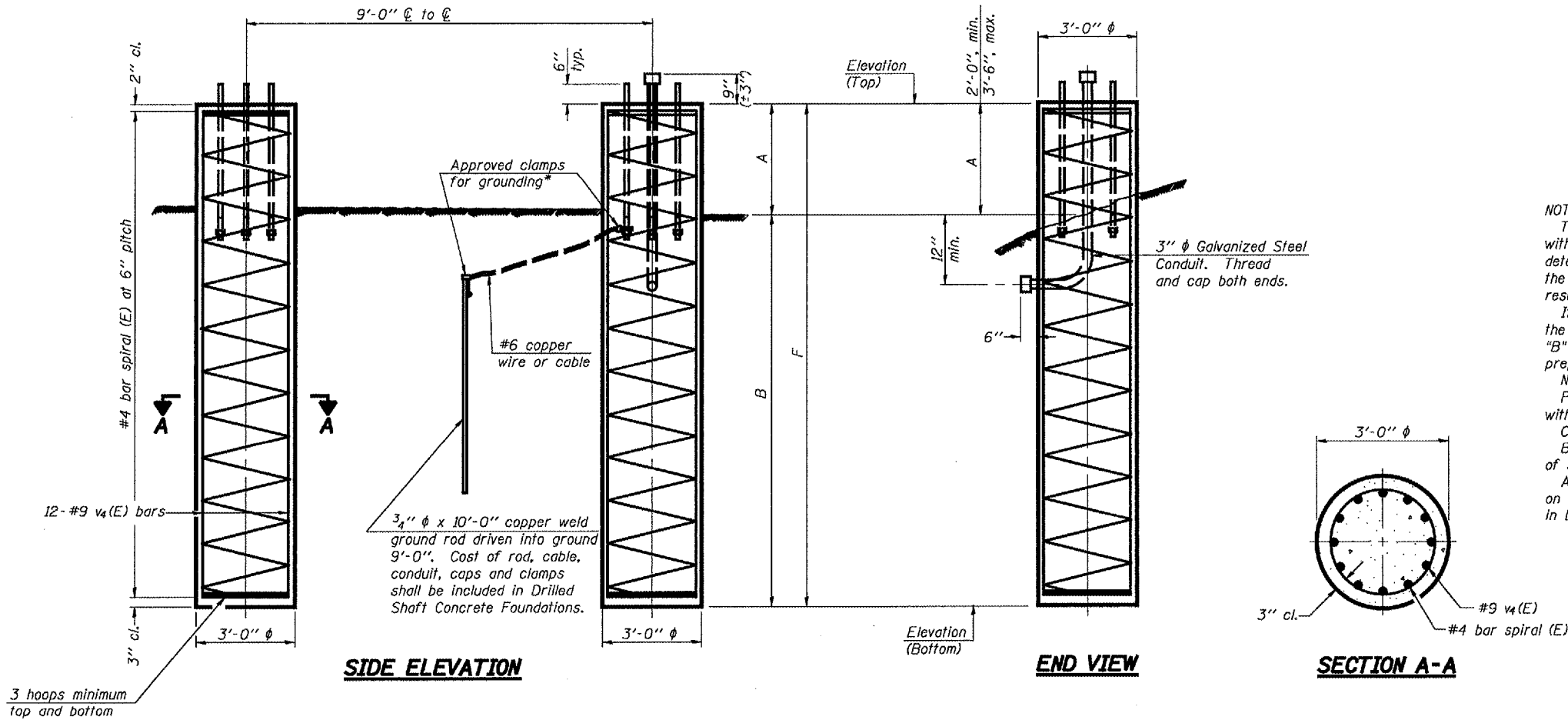

NOTES:

The foundation dimensions shown are based on the presence of mostly cohesive soils with an average Unconfined Compressive Strength (Q_u) of at least 1.25 tsf, which must be determined by previous soil investigations at the jobsite. When other conditions are indicated, the boring data will be included in the plans and the foundation dimensions shown will be the result of site specific designs.

If the conditions encountered are different than those indicated, the Contractor shall notify the Engineer to determine if the foundation dimensions need to be modified. If dimensions "B" or "F" are revised by more than 12" by the Contractor, "as-built" plans shall be prepared and submitted to the District Bureau of Operations for future reference.

No sonotubes or decomposable forms shall be used below the lower conduit entrance. Permanent metal forms or other shielding may not be left in place below that elevation without the Engineer's written permission.

Concrete shall be placed monolithically, without construction joints.

Backfill shall be placed per Article 502 of Standard Specification and prior to erection of support column.

A normal surface finish followed by a Bridge Seat Sealer application will be required on concrete surfaces above the lowest elevation 6" below finished ground line. Cost included in Drilled Shaft Concrete Foundation.

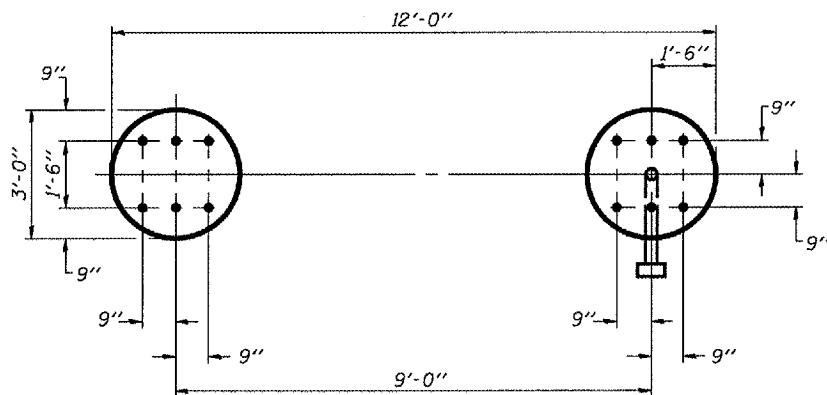

PLAN

Structure Number	Station	Left Foundation			Right Foundation			Class SI Concrete (Cu. Yds.)				
		Elevation Top	Elevation Bottom	A	B	F	Elevation Top		Elevation Bottom	A	B	F
6S0841055R86.9	234+00.00						598.00	577.90	2'-1"	18'-0"	20'-1"	10.62
6S0841055L107.0	202+54.00						591.50	571.17	2'-4"	18'-0"	20'-4"	10.60

DESIGNED	
CHECKED	
DRAWN	
CHECKED	

EXAMINED	200
PASSED	ENGINEER OF BRIDGE DESIGN
	ENGINEER OF BRIDGES AND STRUCTURES

NUMBER	REVISION	DATE

**DETAILS FOR 12" ϕ SUPPORT FRAME
TYPE III-A TRUSS**

**OVERHEAD SIGN STRUCTURES
DRILLED SHAFT DETAILS**

F.A.I. 55 (I-55)
SECTION D-6 ITS #1
SANGAMON COUNTY

STATE OF ILLINOIS
DEPARTMENT OF TRANSPORTATION

ROUTE NO.	SECTION	COUNTY	SHEET NO.	SHEET NO.
F.A.I. 55	D-6 ITS #1	SANGAMON	51	SHEETS
FED. ROAD DIST. NO. 7	ILLINOIS	FED. AID PROJECT		

* Anchor rod shall be ground or filed to bright metal at clamp and cable connection location.

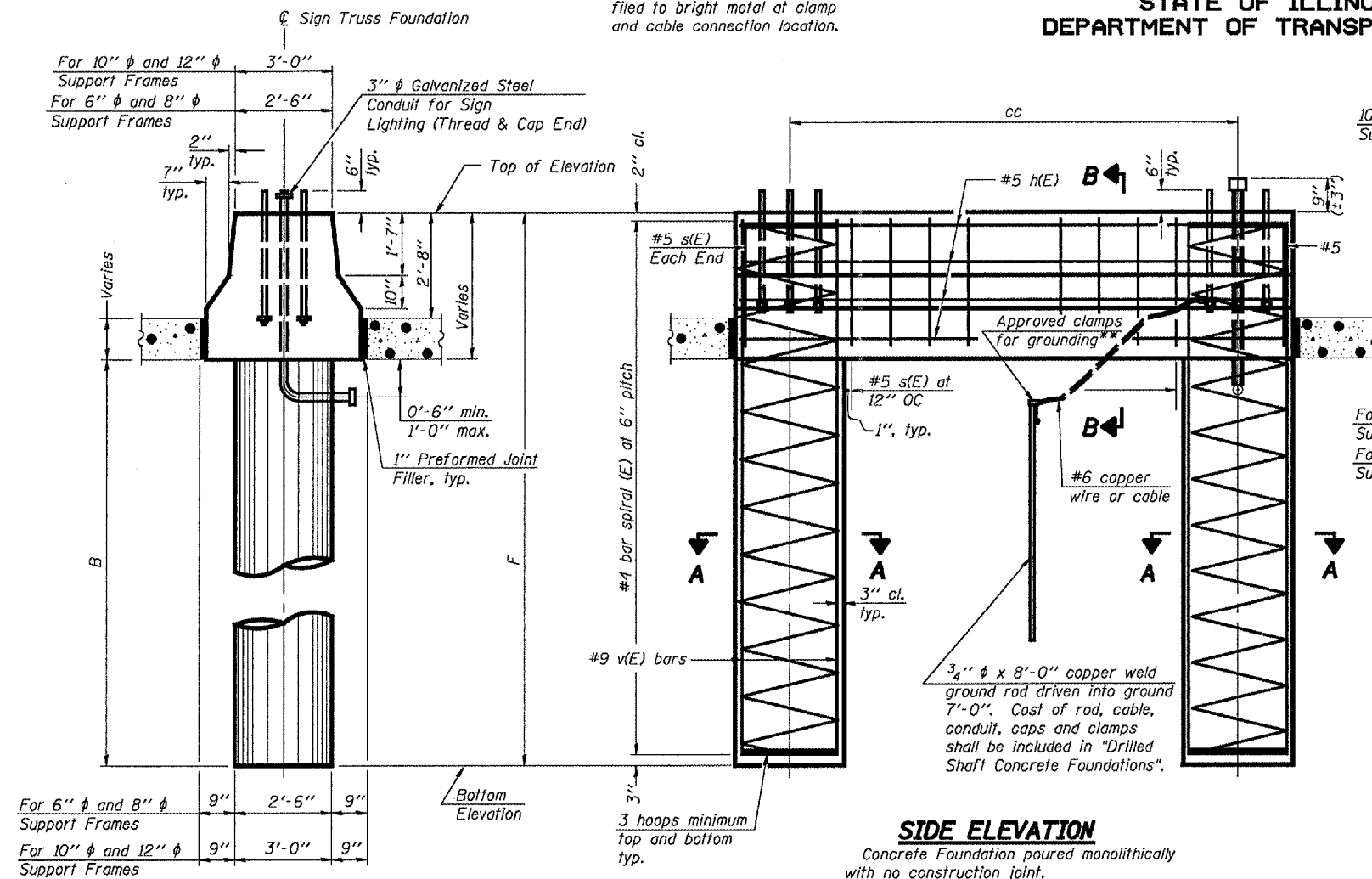

SIDE ELEVATION

Concrete Foundation poured monolithically with no construction joint.

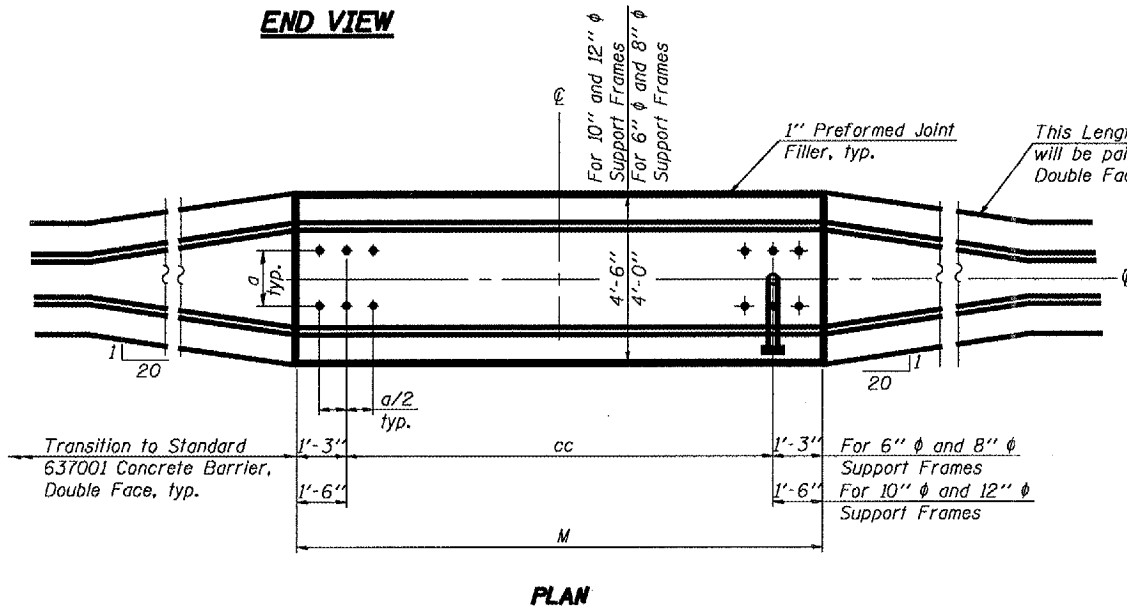

PLAN

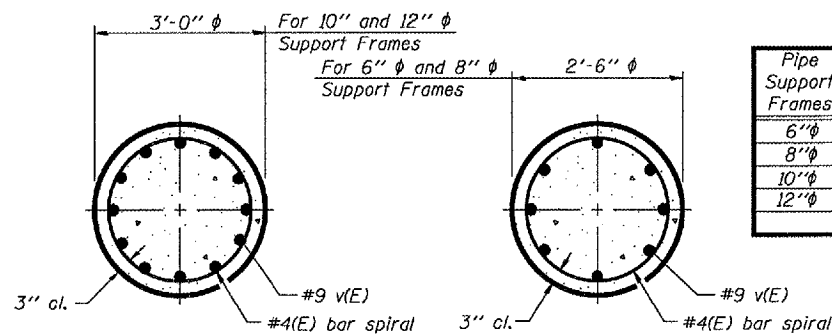

SECTION A-A

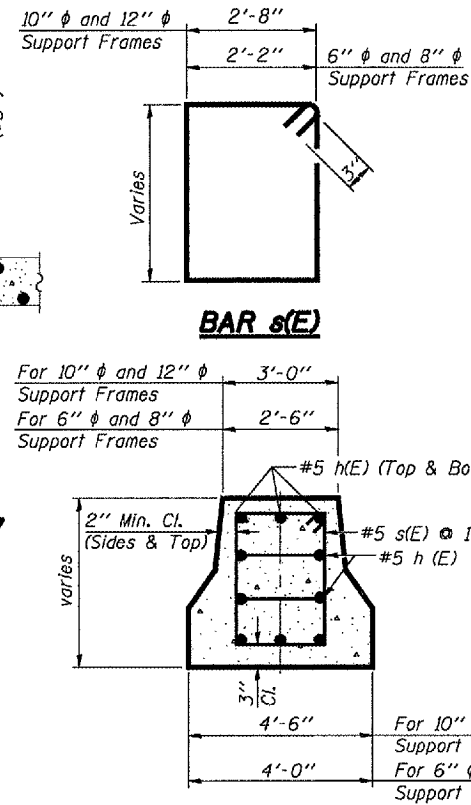

SECTION B-B

NOTES:

The foundation dimensions shown are based on the presence of mostly cohesive soils with an average unconfined compressive strength (Q_u) of at least 1.25 tsf, which must be determined by previous soil investigations at the jobsite. When other conditions are indicated, the boring data will be included in the plans and the foundation dimensions shown will be the result of site specific designs.

If the conditions encountered are different than those indicated, the Contractor shall notify the Engineer to determine if the foundation dimensions need to be modified. If dimensions "B" or "F" are revised by more than 12" by the Contractor, "as-built" plans shall be prepared and submitted to the District Bureau of Operations for future reference.

No sonotubes or decomposable forms shall be used below the lower conduit entrance. Permanent metal forms or other shielding may not be left in place below that elevation without the Engineer's written permission.

Concrete shall be placed monolithically, without construction joints. Backfill shall be placed per Article 502 of Standard Specification and prior to erection of support column.

A normal surface finish followed by a Bridge Seat Sealer application will be required on concrete surfaces above the lowest elevation 6" below finished ground line. Cost included in Drilled Shaft Concrete Foundation.

BAR LIST - EACH FOUNDATION

Bar	Number	Size	Length	Shape
h(E)	10	#5	M less 4"	—
s(E)	Varies	#5	Varies	□
v(E)	16	#9	F less 0'-5"	—
v(E)	24	#9	F less 0'-5"	—

6" ϕ and 8" ϕ Support Frame
10" ϕ and 12" ϕ Support Frame

#4(E) bar spiral - see Side Elevation

Structure Number	Station	Left Foundation				Right Foundation				Class SI Concrete (Cu. Yds.)
		Elevation Top	Elevation Bottom	B	F	Elevation Top	Elevation Bottom	B	F	
6S084I055R86.9	234+00.00	597.17	576.00	18'-0"	21'-2"					13.0
6S084I055L107.0	202+54.00	590.58	569.42	18'-0"	21'-2"					13.0

Pipe Support Frames	cc	M	a	a/2
6" ϕ	7'-0"	9'-6"	0'-11"	5 1/2"
8" ϕ	7'-6"	10'-0"	1'-1 1/2"	6 3/4"
10" ϕ	8'-3"	10'-9"	1'-3"	7 1/2"
12" ϕ	9'-0"	12'-0"	1'-6"	9"

**OVERHEAD SIGN STRUCTURES
MEDIAN SUPPORT FOUNDATION DETAILS**

F.A.I. 55 (I-55)
SECTION D-6 ITS #1
SANGAMON COUNTY

DESIGNED: _____
CHECKED: _____
DRAWN: _____
CHECKED: _____

200
EXAMINED: _____
PASSED: _____
ENGINEER OF BRIDGE DESIGN
ENGINEER OF BRIDGES AND STRUCTURES

OS4-MED 1-7-05

F.A.P. RTE.	SECTION	COUNTY	TOTAL SHEETS	SHEET NO.
	D-6 ITS #1	SANGAMON		52
STA.	TO STA.			
FED. ROAD DIST. NO.	ILLINOIS	FED. AID PROJECT		

GENERAL NOTES

1. THE 10:1 SLOPE CONTROLS NOSE OF ATTENUATOR BASE ELEVATION.
2. ATTENUATOR BASE GRADE PARALLELS EDGE OF PAVEMENT GRADE.
3. SLOPE ADJACENT TO ATTENUATOR BASE SHALL BE 10:1 OR FLATTER.
4. ANY EARTHWORK, INCLUDING GRADING, COMPACTION, AND SEEDING ASSOCIATED WITH THE INSTALLATION OF THE ATTENUATOR BASE IS CONSIDERED INCLUDED IN THE PRICE OF THE ATTENUATOR BASE.
5. ANY EXISTING DRAINAGE STRUCTURES LOCATED WITHIN THE WORKING AREA SHALL BE MODIFIED OR LEFT IN PLACE. WHERE THE EXISTING DRAINAGE STRUCTURES ARE TO REMAIN IN PLACE, THE SLOPES ARE TO BE CONSTRUCTED AS DIRECTED BY THE ENGINEER.
6. ATTENUATOR BASE THICKNESS SHALL BE ACCORDING TO THE MANUFACTURER'S SPECIFICATIONS.

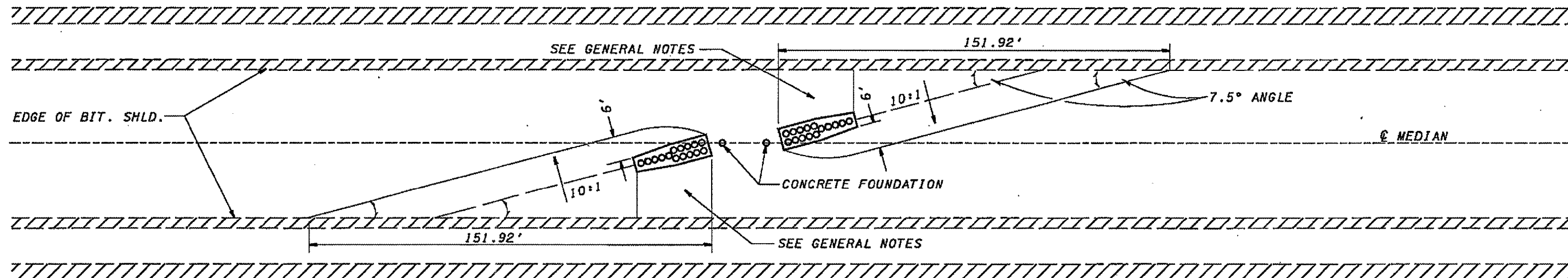

INERTIAL BARRIER LAYOUT AND GRADING PLAN

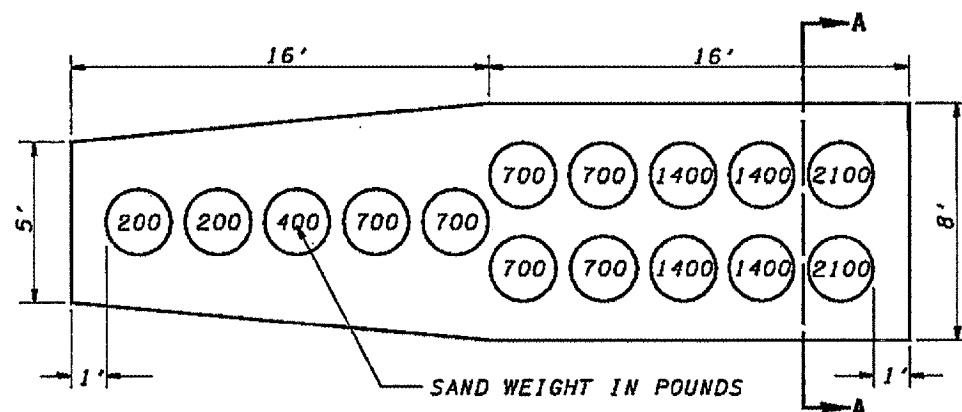

INERTIAL BARRIER MODULE ARRAY AND ATTENUATOR BASE PLAN

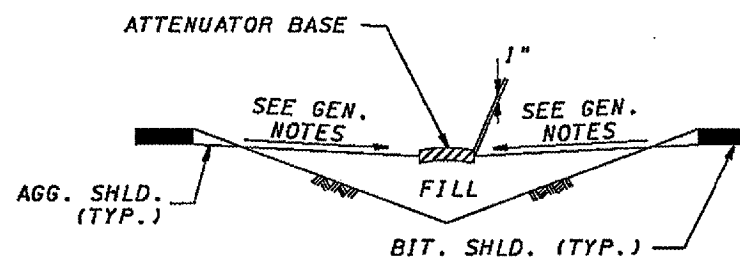

SECTION A - A

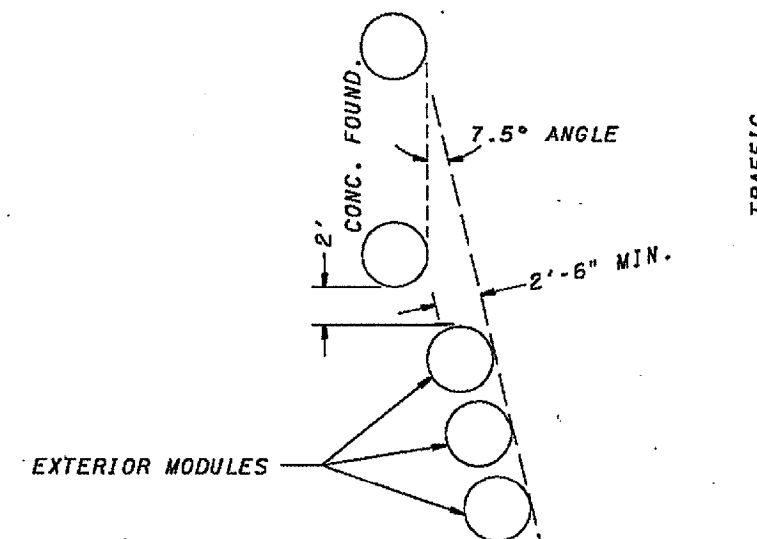

EXTERIOR MODULE LAYOUT

QUANTITIES

ITEM	UNIT	TOTAL
IMPACT ATTENUATOR (NON-REDIRECTIVE), TEST LEVEL 3	EACH	4
ATTENUATOR BASE	SQ. YD.	51.6

REVISIONS		ILLINOIS DEPARTMENT OF TRANSPORTATION
NAME	DATE	
		<p align="center">INERTIAL BARRIER INSTALLATION DETAILS</p> <p>SCALE: VERT. _____ HORIZ. _____ DATE _____ DRAWN BY _____ CHECKED BY _____</p>

F.A. RY.	SECTION	COUNTY	TOTAL SHEETS	SHEET NO.
	D-6 ITS #1	SANGAMON		53
STA.	TO STA.			
FED. ROAD DIST. NO.	ILLINOIS FED. AID PROJECT			

NOTES:

1. THE CONTRACTOR SHALL SUBMIT DETAIL PLANS AND CALCULATIONS OF CCTV ARM AND MOUNTING HARDWARE FOR THE POLE FOR APPROVAL BY THE ENGINEER.
2. MOUNTING BRACKET DETAILS MAY VARY DEPENDING UPON EQUIPMENT MANUFACTURER.
3. INSTALL GROUNDING SYSTEM IN ACCORDANCE WITH SECTION 807 OF THE IDOT STANDARD SPECIFICATIONS.
4. CONTRACTOR SHALL CONTACT ENGINEER DURING CAMERA INSTALLATION TO DETERMINE ACTUAL CAMERA HEIGHT IN FIELD

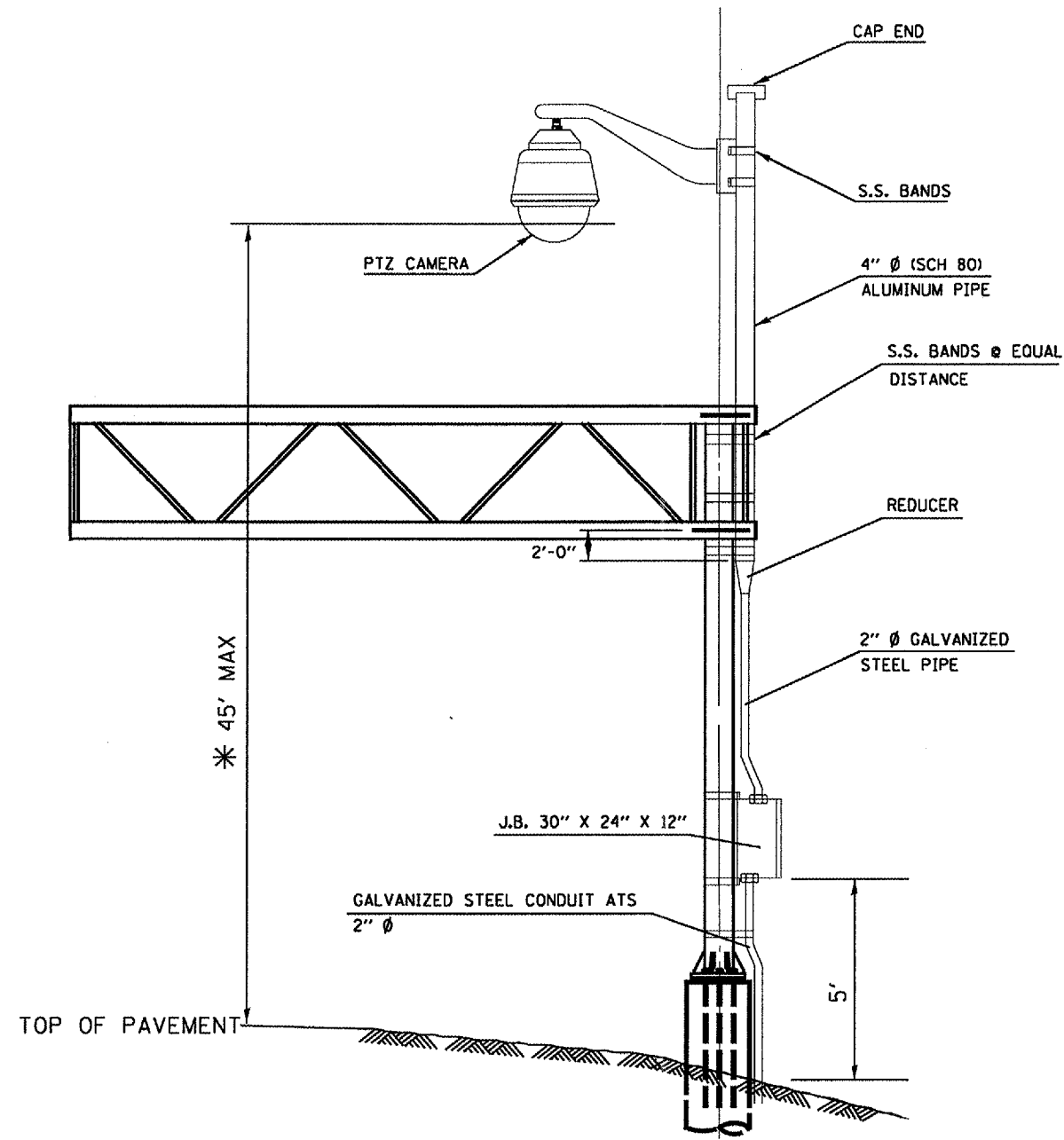

TYPICAL ELEVATION
NOT TO SCALE

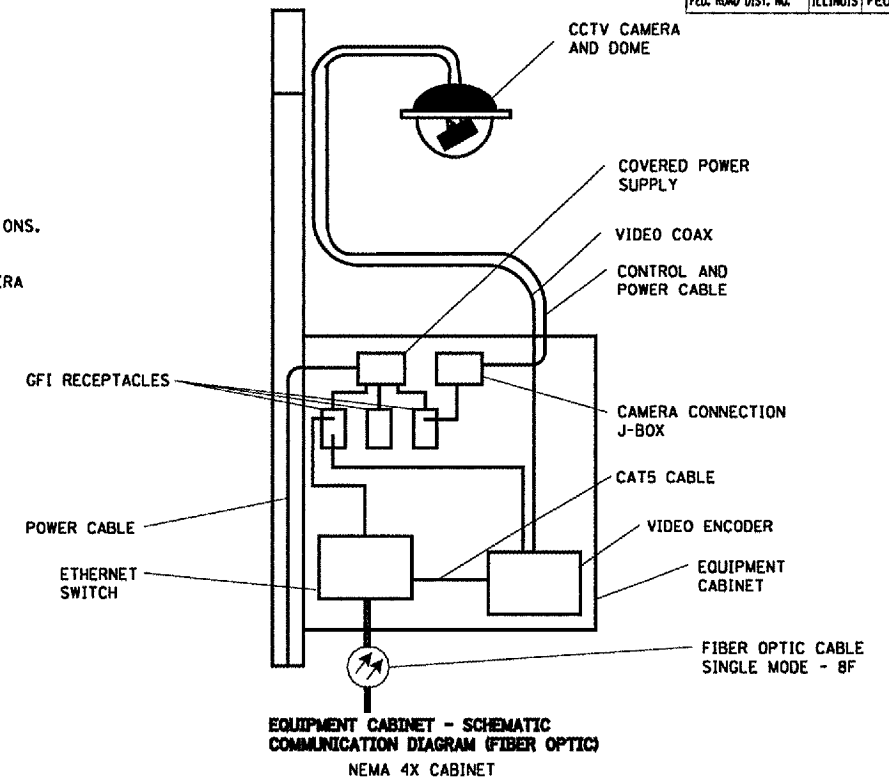

EQUIPMENT CABINET - SCHEMATIC COMMUNICATION DIAGRAM (FIBER OPTIC)
NEMA 4X CABINET

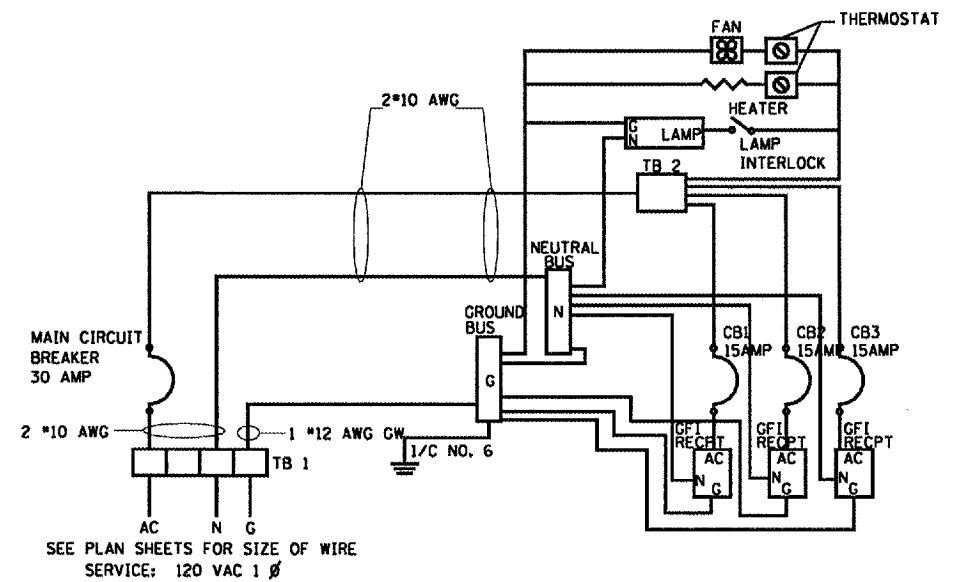

EQUIPMENT CABINET - WIRING DIAGRAM
NEMA 4X CABINET

PLOT DATE * * DATE *
 FILE NAME * * FILE *
 PLOT SCALE * * SCALAR *
 USER NAME * * USER *

REVISIONS	DATE

ILLINOIS DEPARTMENT OF TRANSPORTATION
CCTV SYSTEM MOUNTING AND WIRING DETAILS
 D-6 ITS
 SANGAMON COUNTY
 SCALE: VERT. NOT TO SCALE DRAWN BY KDA
 DATE MAY 2005 CHECKED BY

F.A. RTE.	SECTION	COUNTY	TOTAL SHEETS	SHEET NO.
	D-6 ITS #1	SANGAMON		54
STA.		TO STA.		
FED. ROAD DIST. NO.	ILLINOIS	FED. AID PROJECT		

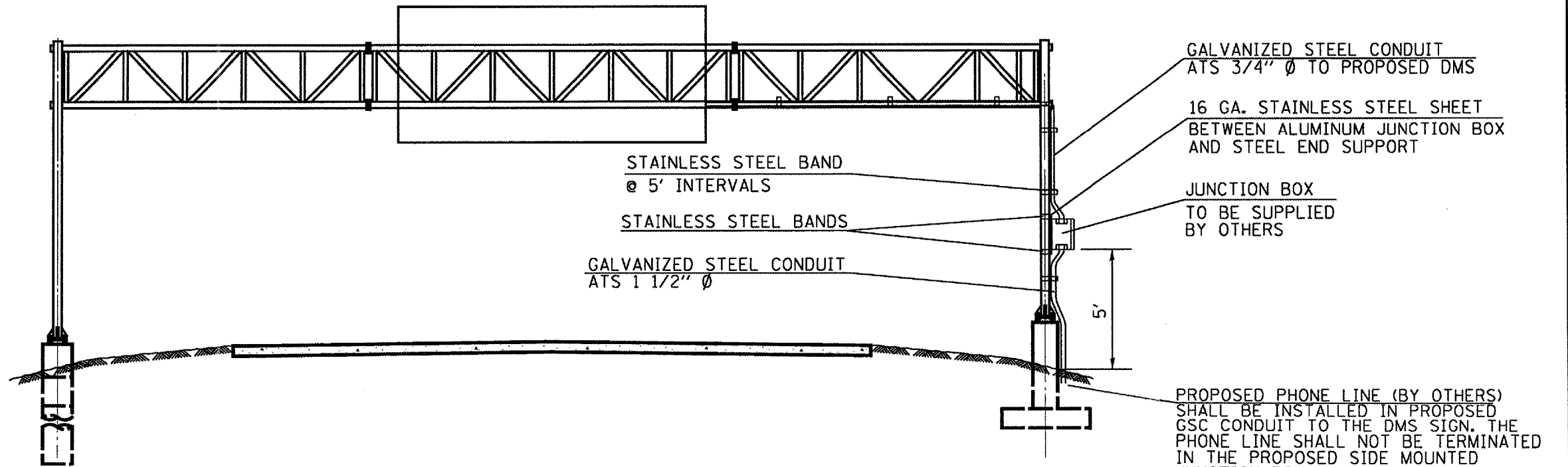

TYPICAL ELEVATION
NOT TO SCALE

REVISIONS	
NAME	DATE

ILLINOIS DEPARTMENT OF TRANSPORTATION
**DMS MOUNTING
 AND WIRING DETAILS**
 D-6 ITS
 SANGAMON COUNTY
 SCALE: VERT. NOT TO SCALE DRAWN BY KDA
 DATE CHECKED BY

PLOT DATE * DATE*
 FILE NAME * FILE#*
 PLOT SCALE * SCALE*
 USER NAME * USER*

Rev.

F.A. RTE.	SECTION	COUNTY	TOTAL SHEETS	SHEET NO.
	D-6 ITS #1	SANGAMON		55
STA.		TO STA.		
FED. ROAD DIST. NO.	ILLINOIS	FED. AID PROJECT		

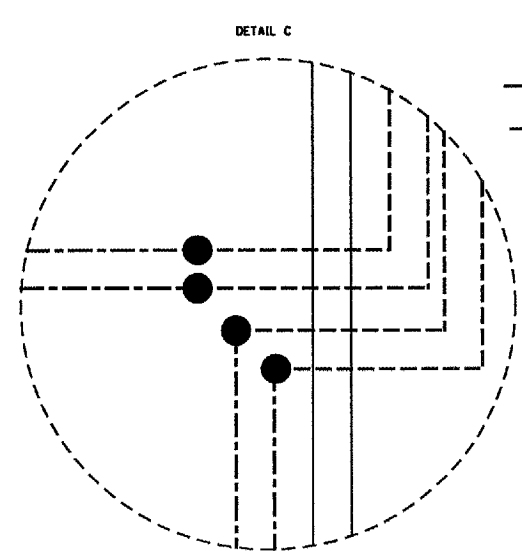
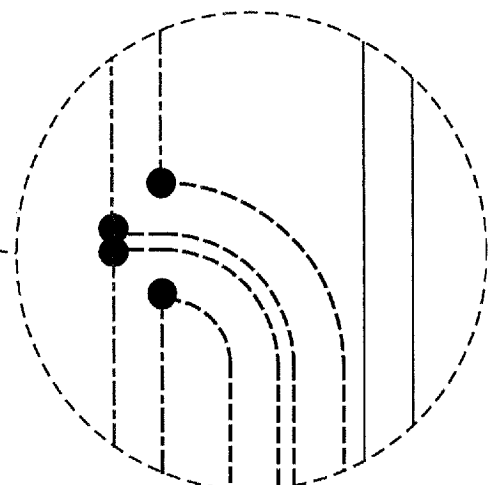
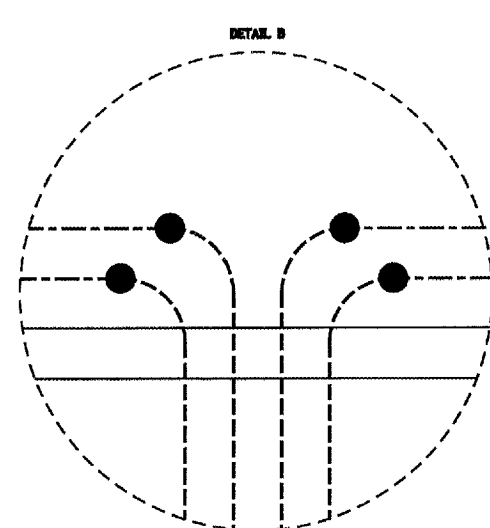
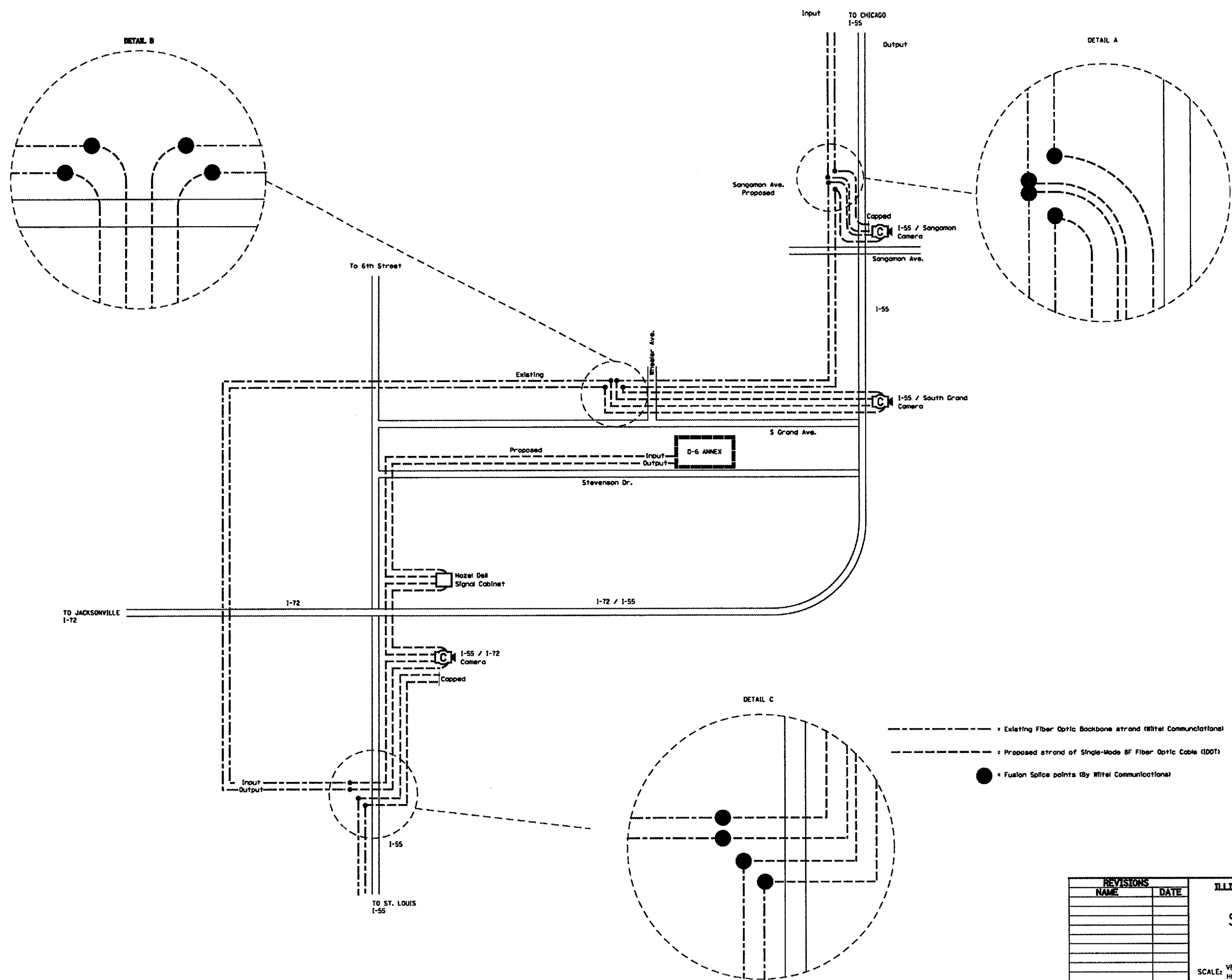

- - - - - Existing Fiber Optic Backbone strand (Mital Communications)
- - - - - Proposed strand of Single-Mode 8F Fiber Optic Cable (100T)
- Fusion Splice points (By Mital Communications)

PLOT DATE * @DATE
 FILE NAME * @FILEL
 PLOT SCALE * @SCALE
 USER NAME * @USER

REVISIONS	
NAME	DATE

ILLINOIS DEPARTMENT OF TRANSPORTATION
FIBER OPTIC SYSTEM SCHEMATIC
 D-6 ITS
 SANGAMON COUNTY
 SCALE: VERT. NOT TO SCALE DRAWN BY KDA
 DATE CHECKED BY

F.A. RTE.	SECTION	COUNTY	TOTAL SHEETS	SHEET NO.
	D-6 ITS #1	SANGAMON		56
STA.		TO STA.		
FED. ROAD DIST. NO.	ILLINOIS FED. AID PROJECT			

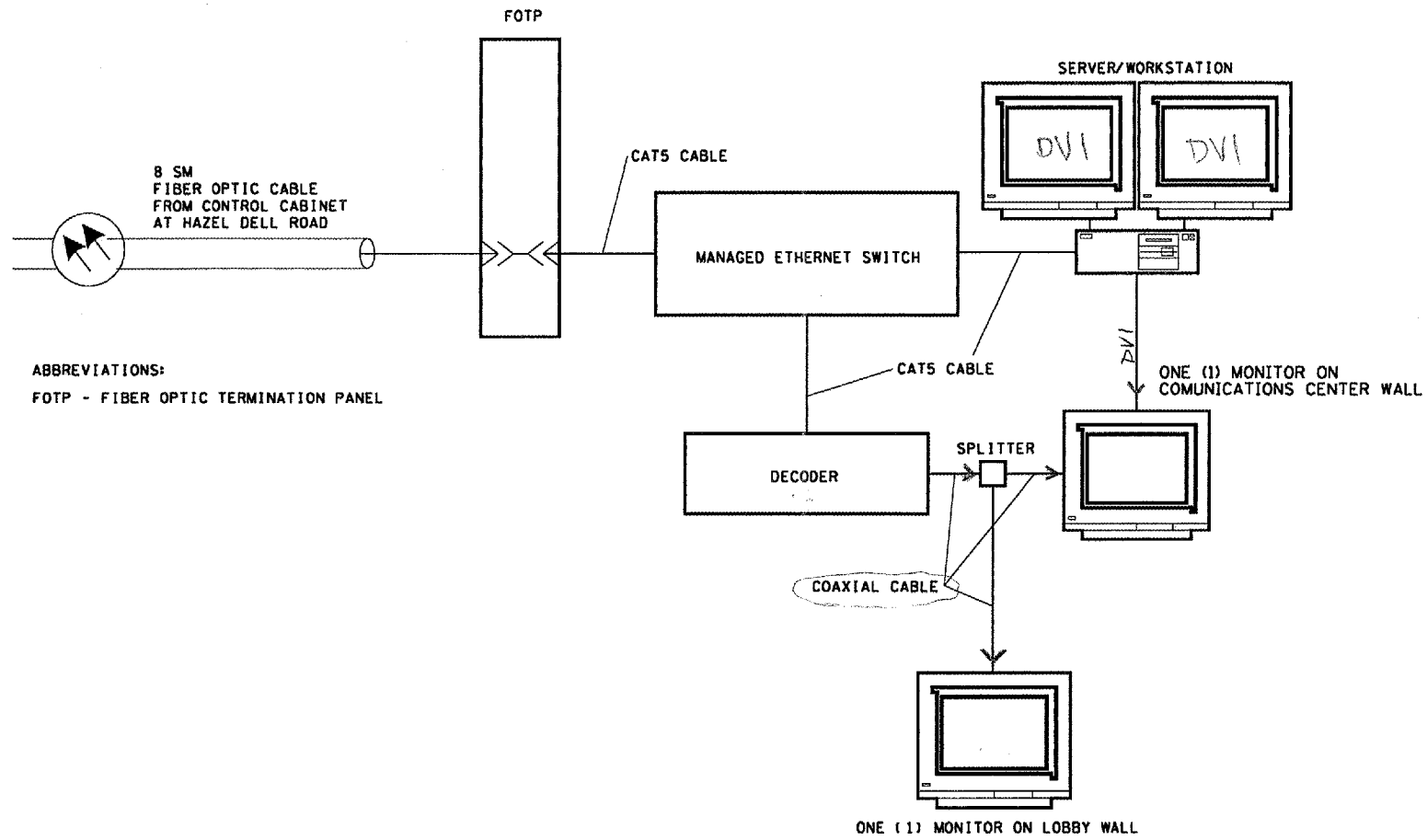

ABBREVIATIONS:
FOTP - FIBER OPTIC TERMINATION PANEL

COMMUNICATION CENTER CONNECTION DETAIL

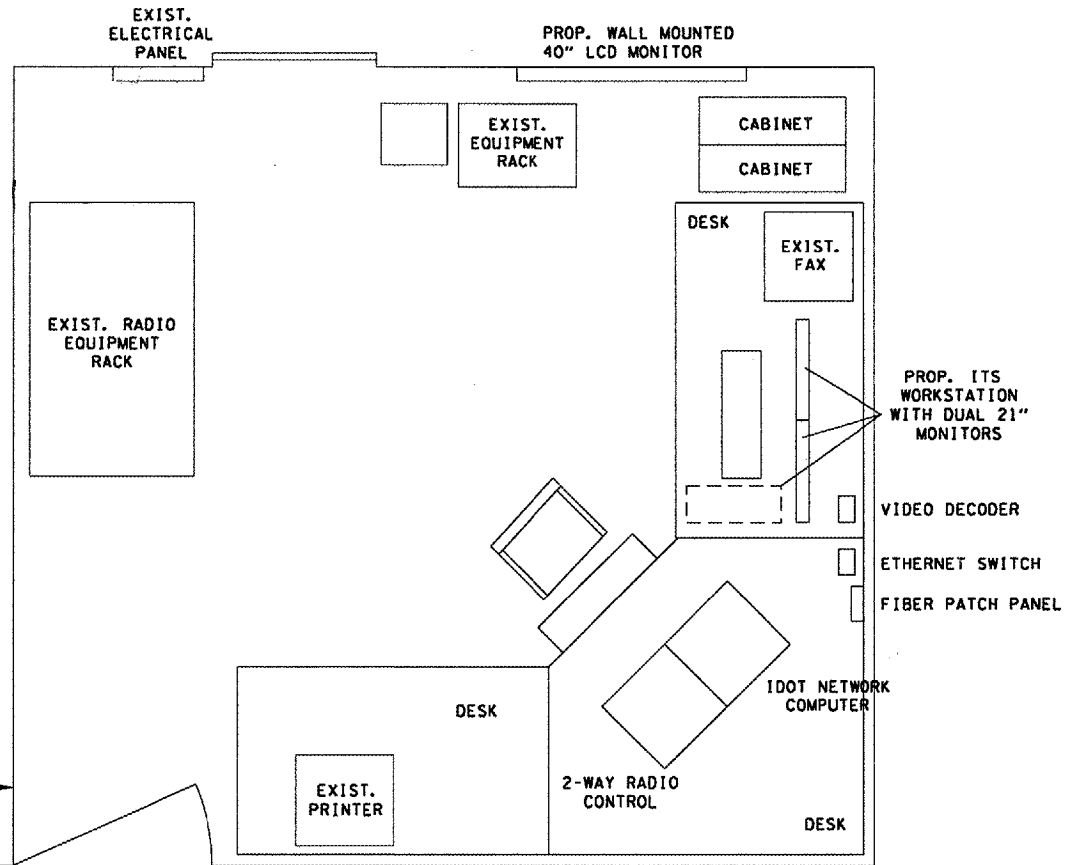

APPROX. 75 FT.

- NOTES:
1. ALL ITEMS SHOWN TO BE INCLUDED IN THE COST OF 'COMMUNICATIONS CENTER' PAY ITEM.

COMMUNICATION CENTER ROOM DETAIL

PROP. WALL MOUNTED 30\"/>

REVISIONS	
NAME	DATE

ILLINOIS DEPARTMENT OF TRANSPORTATION
COMMUNICATION CENTER SYSTEM SCHEMATIC

D-6 ITS
SANGAMON COUNTY
SCALE: VERT. NOT TO SCALE
HORIZ. DATE
DRAWN BY: KDA
CHECKED BY: