

- DOWEL BASKET NOTES**
- #9 GA. WIRE SPACER BAR ARC WELDED TO THE BOTTOM OF TOP SPACER BAR (MAY BE MECHANICALLY ATTACHED IN LIEU OF WELDING); 3 REQUIRED PER UNIT. THIS WIRE MUST BE CUT OR REMOVED PRIOR TO PAVING.
 - DOWEL BAR DIAMETER, LENGTH & SPACING SHALL BE AS SHOWN IN TABLE 2 OF JOINING DETAILS SHEET.
 - DOWELS SHALL BE EPOXY COATED FULL LENGTH OF DOWEL IMMEDIATELY PRIOR TO PAVING, THE FREE END OF EACH DOWEL SHALL BE LUBRICATED OR OILED, FOR HALF THE LENGTH OF THE DOWEL.

REVISIONS		
NUMBER	BY	DATE

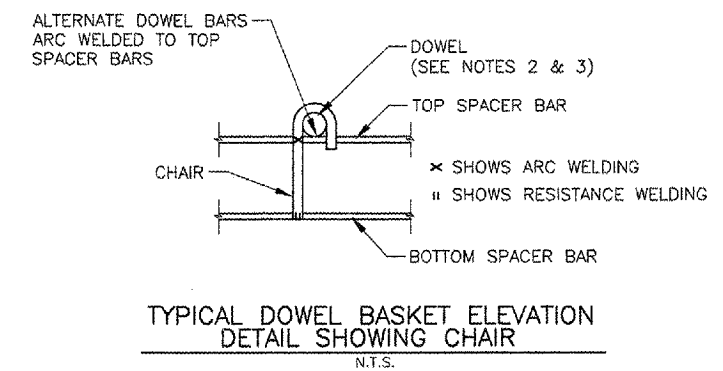
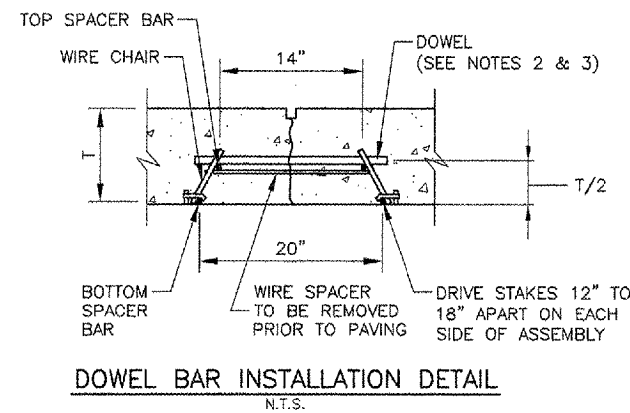
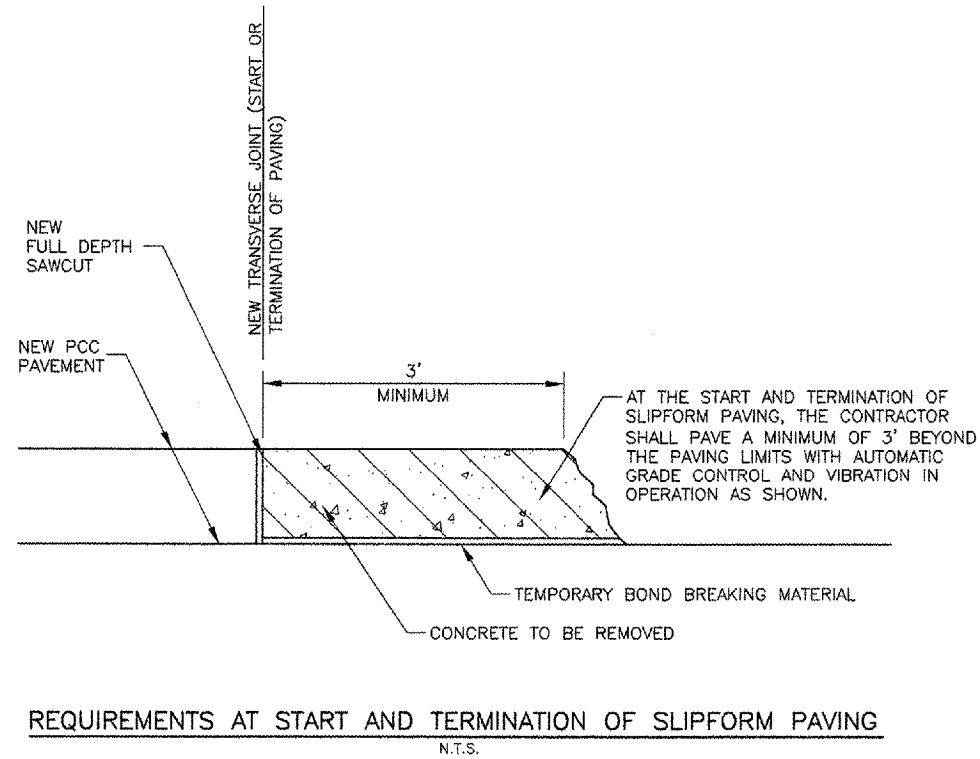
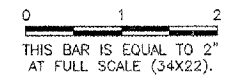

DOWEL BASKET DETAILS

UNIVERSITY OF ILLINOIS
 WILLARD AIRPORT
 REHABILITATE AIR CARRIER RAMP
 PAVING AND MISCELLANEOUS DETAILS
 SHEET 1

© Copyright CMT, Inc.
CMT
 CRAWFORD, MURPHY & TILLY, INC.
 CONSULTING ENGINEERS
 License No. 984-000613

DESIGN BY:	CMT
DRAWN BY:	CMT
CHECKED BY:	SMS
APPROVED BY:	<i>[Signature]</i>
DATE:	06/10/2005
JOB No:	03059-03-00
IL PROJECT:	CM-3449
A.I.P. PROJECT:	3-17-0016-22
SHEET	32 OF 58 SHEETS