

Hexagon locknut and washer (top), leveling nut and washer (bottom). Galvanize per AASHTO M232. Nuts shall each be tightened against base plate with 200 lb.-ft. minimum torque.

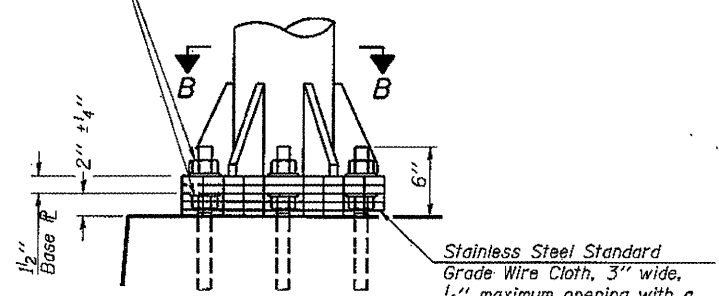

DETAIL B

Ribs shall be cut to fit slope of pipe.
Stainless Steel Standard Grade Wire Cloth, 3" wide, 1/4" maximum opening with a minimum wire diameter of AWG. No. 16 with a minimum 2" lap. Secure to base plate after erection with 3/4" stainless steel banding.

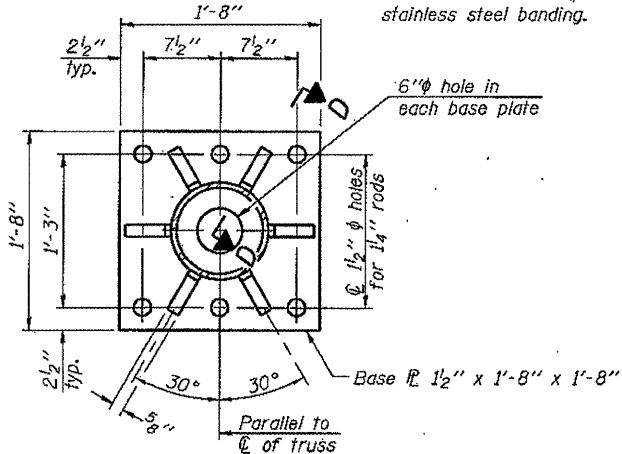

SECTION B-B

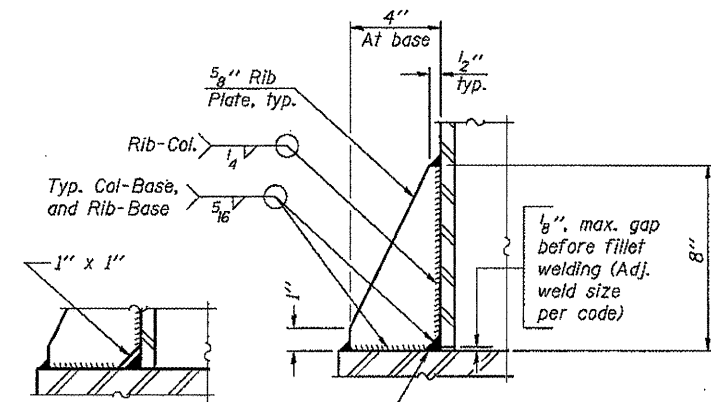

SECTION D-D

** Alternate detail if welding col. to base plate first, then snip inside corner of ribs. Terminate weld on rib 1/4" from snip.
No snip req'd. at rib inside corner if placed before col. to base plate welding.

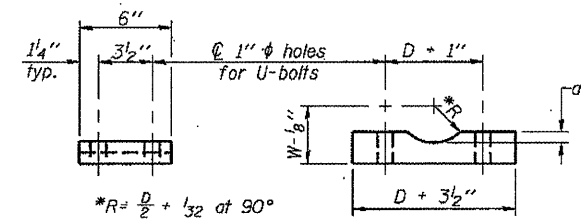

SADDLE SHIM DETAIL

ASTM B26 Alloy 356-F or ASTM B209 Alloy 6061-T651 (4 required per sign truss)

Truss Chord Nominal Dia.	a
5"	3/4"
5 1/2"	13/16"
6"	7/8"
6 1/2"	15/16"
7"	1"

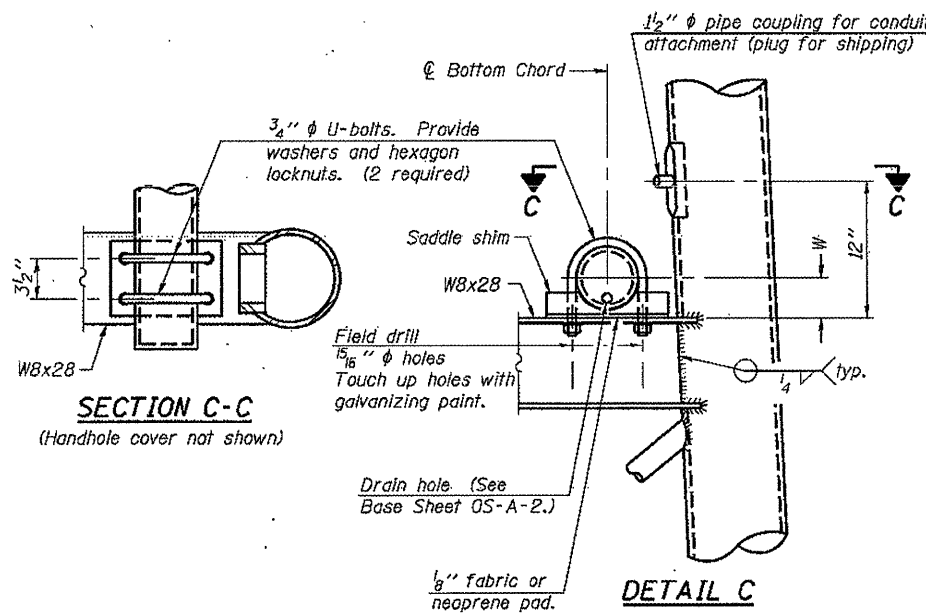

SECTION C-C
(Handhole cover not shown)

DETAIL C

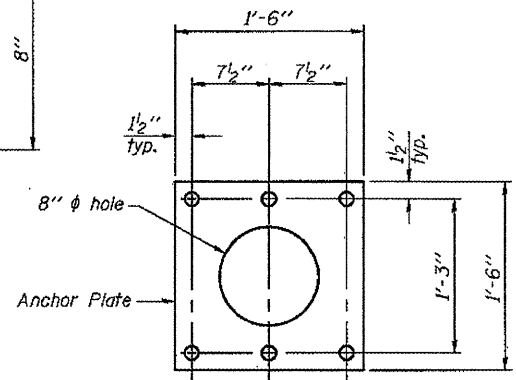

Anchor Plate

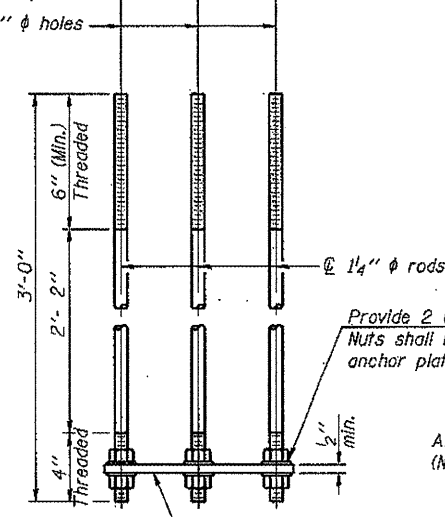

ANCHOR ROD DETAIL
Spread Footing Foundation

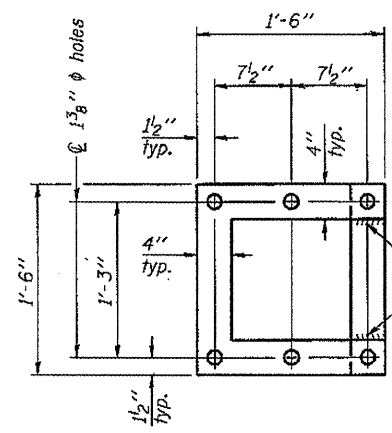

POSITIONING PLATE(S)

At each location, provide 1/4" thick positioning plate(s) and six (6) additional nuts to be used with leveling nuts to maintain anchor bolts position during concrete placement.

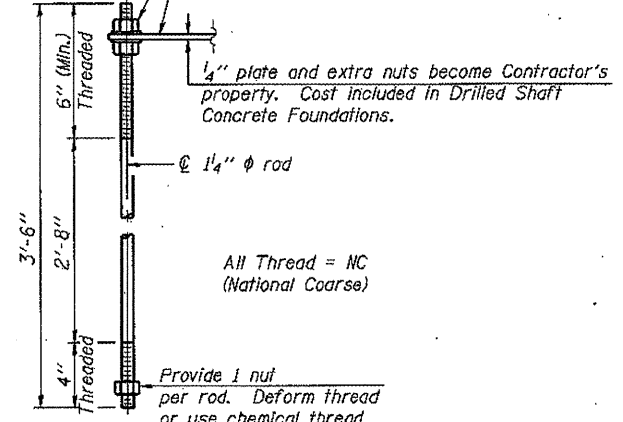

ANCHOR ROD DETAIL
Drilled Shaft Foundation

Anchor rods shall conform to ASTM F1554 Grade 105. Galvanize upper 12" minimum per AASHTO M232. No welding shall be permitted on rods.

10" PIPE SUPPORT FRAME DETAILS

OS-A-6A

1-20-11

FILE NAME =	USER NAME =	DESIGNED -	REVISED -
		CHECKED -	REVISED -
		DRAWN -	REVISED -
		CHECKED -	REVISED -

STATE OF ILLINOIS
DEPARTMENT OF TRANSPORTATION

OVERHEAD SIGN STRUCTURES
SUPPORT FRAME DETAILS - ALUMINUM TRUSS

F.A. RTE.	SECTION	COUNTY	TOTAL SHEETS	SHEET NO.
Various	D-1 DVD SIGN STR. REPL. 12-02	VARIOUS	39	11
			CONTRACT NO. 46175	
(ILLINOIS) FED. AID PROJECT				