

DRIVEWAY SCHEDULE

STREET	STATION	OFF	L/R	DRIVEWAY TYPE	DRIVEWAY WIDTH	RADIUS	Ⓐ	Ⓑ	Ⓓ	DRIVEWAY PAVEMENT ①	PAVEMENT OUTSIDE R.O.W. ②
MCLEAN BLVD	59+96.64	41.6'	LT	CE	30.0'	15'	59+81.88	60+11.41	26.4'	PCC	HMA
MCLEAN BLVD	61+26.66	46.2'	LT	CE	30.0'	5'	61+11.83	61+41.48	1.0'	PCC	HMA
MCLEAN BLVD	62+44.82	40.0'	LT	CE	35.0'	5'	62+27.37	62+62.30	1.0'	PCC	HMA
FLEETWOOD DR	302+44.20	32.1'	RT	CE	31.8'	15'	302+28.28	302+60.12	1.0'	HMA	-
FLEETWOOD DR	304+24.31	33.1'	RT	CE	36.0'	15'	304+06.28	304+42.35	0.0'	HMA	-
FLEETWOOD DR	304+78.53	40.7'	LT	CE	25.0'	15'	304+66.32	304+91.26	10.0'	HMA	HMA
FLEETWOOD DR	306+12.13	30.8'	RT	CE	25.9'	15'	305+99.18	306+25.09	4.5'	PCC	HMA
FLEETWOOD DR	306+27.09	44.6'	LT	CE	29.5'	15'	306+12.32	306+41.86	21.0'	PCC	HMA
FLEETWOOD DR	306+98.36	47.3'	LT	CE	35.0'	15'	306+80.86	307+15.86	10.3'	PCC	HMA
FLEETWOOD DR	307+10.56	39.3'	RT	CE	18.0'	15'	307+01.58	307+19.53	6.8'	PCC	HMA
FLEETWOOD DR	307+77.84	43.7'	RT	CE	35.2'	15'	307+60.23	307+95.44	4.0'	PCC	HMA
FLEETWOOD DR	308+26.07	48.0'	LT	CE	32.8'	15'	308+09.65	308+42.48	6.6'	PCC	HMA
WELD RD	6+19.85	48.9'	RT	CE	23.8'	15'	6+07.95	6+31.76	0.0'	HMA	-
WELD RD	7+32.60	49.0'	RT	CE	24.4'	15'	7+20.39	7+44.71	0.0'	HMA	-
WELD RD	9+02.39	49.3'	RT	CE	36.3'	15'	8+84.23	9+20.55	0.0'	HMA	-
WELD RD	10+22.21	49.9'	RT	CE	28.3'	15'/20'	10+08.07	10+36.36	0.0'	HMA	-
WELD RD	11+73.29	48.1'	RT	CE	28.0'	-	11+59.31	11+87.27	0.0'	HMA	-
WELD RD	14+54.79	44.2'	RT	CE	19.4'	-	14+45.02	14+64.56	0.0'	HMA	-
WELD RD	15+65.12	39.9'	RT	CE	34.4'	-	15+47.80	15+82.44	0.0'	HMA	-
WELD RD	16+26.21	36.4'	RT	CE	22.5'	15'	16+14.90	16+32.51	0.0'	HMA	-
WELD RD	17+15.89	32.0'	RT	CE	25.6'	15'	17+03.01	12+28.76	0.0'	HMA	-
SHEPARD DR	21+94.89	34.1'	RT	CE	37.6'	-	21+77.46	22+12.33	0.0'	HMA	-
SHEPARD DR	22+52.67	33.5'	RT	CE	22'	15'	22+42.67	22+62.67	0.0'	PCC	-
SHEPARD DR	28+14.85	34.3'	LT	CE	27'	16'	28+01.35	28+28.35	0.0'	PCC	-
SHEPARD DR	28+91.04	34.3'	LT	CE	16.1'	-	28+83.00	28+99.00	0.0'	PCC	-
SHEPARD DR	29+43.74	34.4'	LT	CE	21.8'	13'	29+32.80	29+54.67	0.0'	HMA	-
SHEPARD DR	29+78.63	26.1'	RT	CE	25.2'	4.8'	29+66.02	29+91.24	0.0'	HMA	-

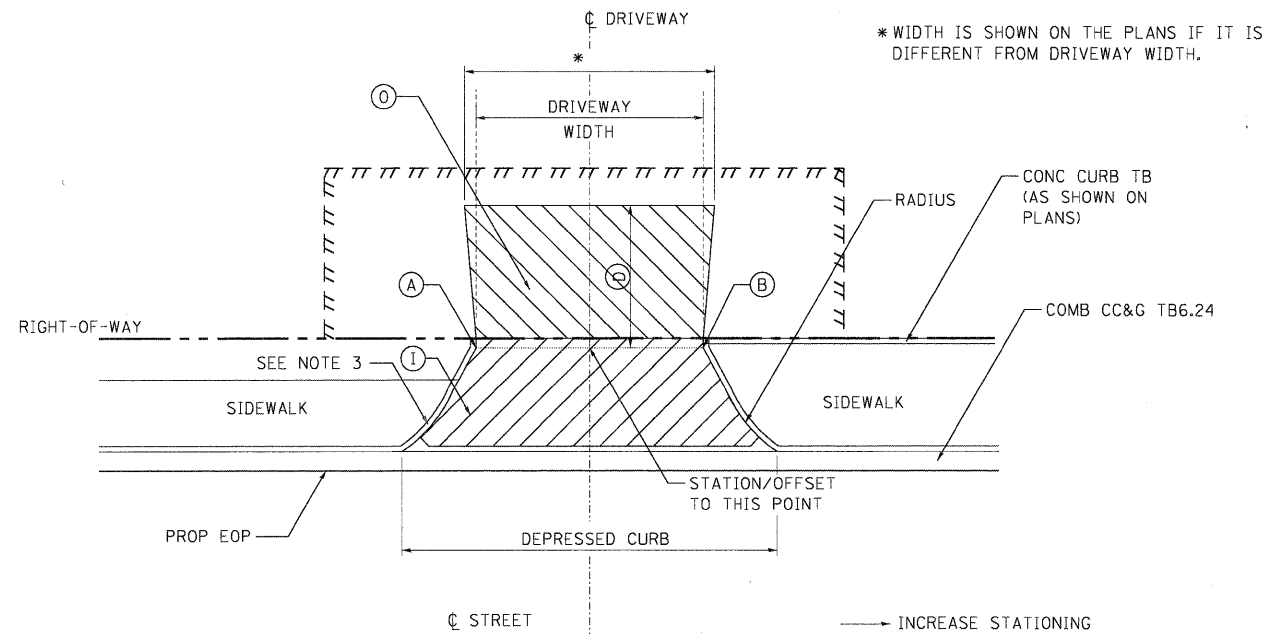
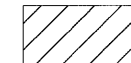
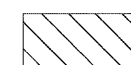

 DRIVEWAY PAVEMENT TYPE INSIDE R.O.W. ①
 DRIVEWAY PAVEMENT TYPE OUTSIDE R.O.W. ②

TYPICAL COMMERCIAL URBAN DRIVEWAY

- NOTES:**
- ALL DRIVEWAYS SHALL BE IN ACCORDANCE WITH IDOT DISTRICT ONE STANDARDS BD-01 AND BD-02 AND THE LATEST EDITION OF THE HANDBOOK FOR POLICY ON PERMITS FOR ACCESS DRIVEWAYS TO STATE HIGHWAYS.
 - ALL THE DRIVEWAY PAVEMENT THICKNESSES FOR PCC AND HMA SHALL BE IN ACCORDANCE WITH IDOT DISTRICT ONE STANDARDS BD-01 AND BD-02.
 - SEE PLANS FOR WHETHER THE CURB IS PRESENT OR NOT. THE CURB SHALL BE "CONC CURB TB" UNLESS OTHERWISE SPECIFIED ON THE PLANS.

11/15/2011 10:58:11 AM \\S:\0044\LAN\VAULT\IDTRANS\07\2282\23779\081\CIVIL\CAD\606\98\SHEET\01606\98\51T\ROAD\DET\081.DOC