

DATE	
BY	
DESIGNED	
DRAWN	
CHECKED	
DATE	
REVISIONS	
NO.	

DATE	
BY	
DESIGNED	
DRAWN	
CHECKED	
DATE	
REVISIONS	
NO.	

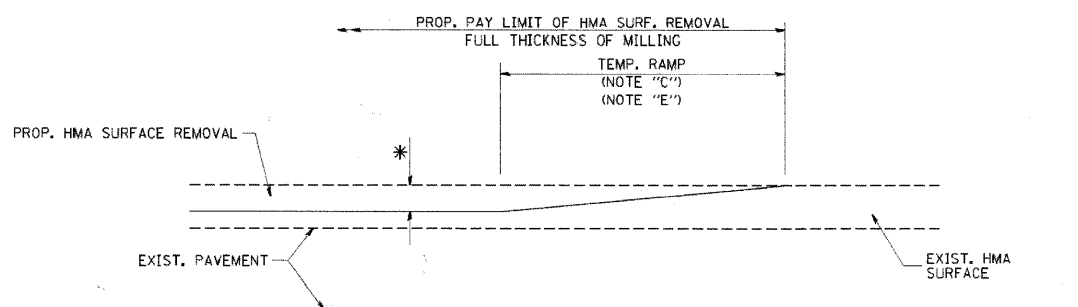

MILLED TEMPORARY RAMP
(FOR BUTT JOINT AND HMA TAPER SEE DETAIL BELOW)

OPTION 1

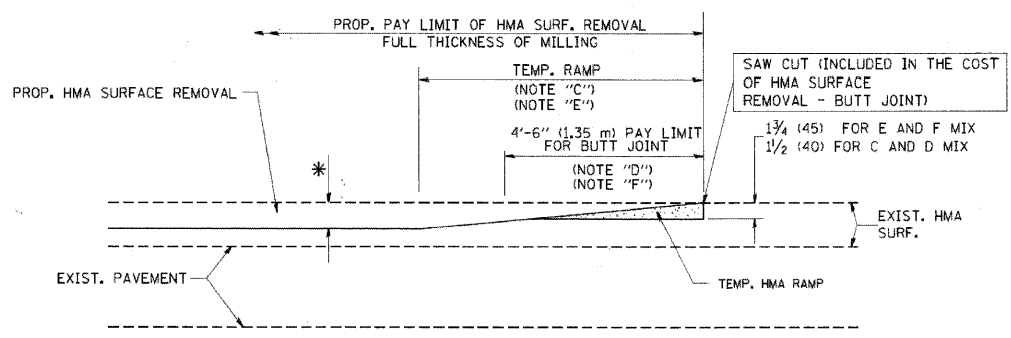

HMA CONSTRUCTED TEMPORARY RAMP
(FOR BUTT JOINT AND HMA TAPER SEE DETAIL BELOW)

OPTION 2

TYPICAL TEMPORARY RAMP

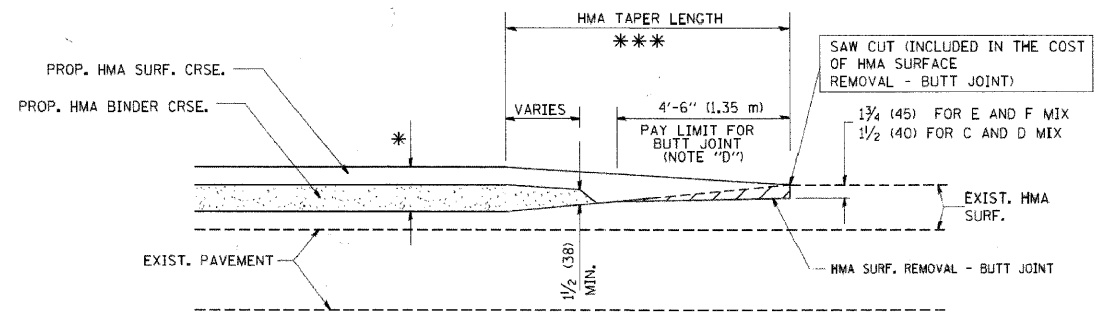

BUTT JOINT AND HMA TAPER

TYPICAL BUTT JOINT AND HMA TAPER FOR MILLING AND RESURFACING

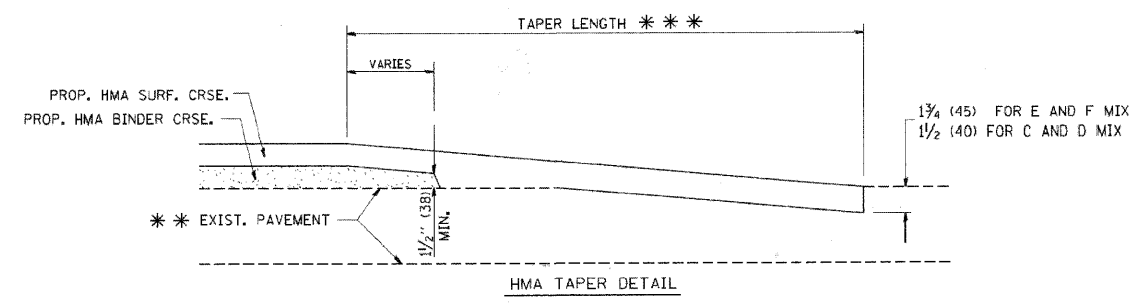
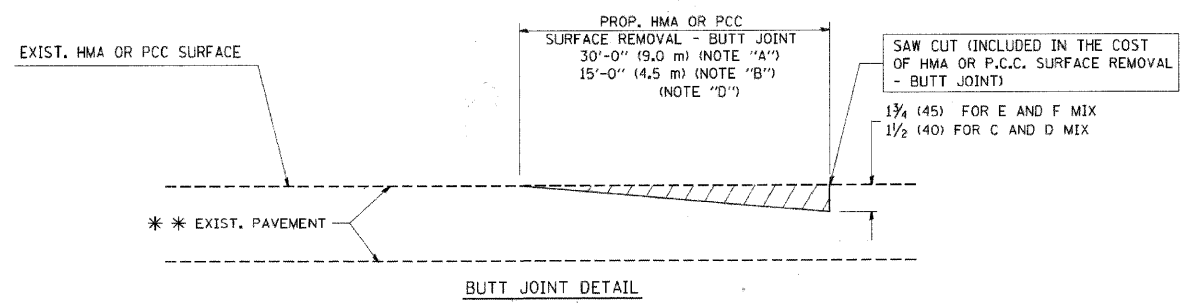

TYPICAL BUTT JOINT AND HMA TAPER FOR RESURFACING ONLY

*** PC CONCRETE, HMA OR HMA RESURFACED PAVEMENT.

NOTES

- A: MAINLINE ROADWAYS AND MAJOR SIDE ROADS.
- B: MINOR SIDE ROADS.
- C: THE TEMP. RAMP SHALL BE CONSTRUCTED IMMEDIATELY UPON REMOVAL OF THE EXISTING HMA SURFACE.
- D: THE BUTT JOINT SHALL BE CONSTRUCTED IMMEDIATELY PRIOR TO PLACING THE PROPOSED HMA COURSES.
- E: TAPER THE TEMP. RAMP AT A RATE OF 3'-0" (900 mm) PER 1 INCH (25 mm) OF MILLING THICKNESS.
- F: INSTALLATION AND REMOVAL OF THE 4'-6" (1.35 m) TEMP. RAMP IS INCLUDED IN COST OF HMA SURFACE REMOVAL - BUTT JOINT
- G: SEE ARTICLE 406.08 AND 406.14 OF THE STANDARD SPECIFICATIONS FOR "HMA AND/OR PCC SURFACE REMOVAL, BUTT JOINT".
- * SEE TYPICAL SECTIONS FOR MILLING THICKNESS.
- *** 20'-0" (6.1 m) PER 1 (25) RESURFACING (NOTE "A")
10'-0" (3.0 m) PER 1 (25) RESURFACING (NOTE "B")

BASIS OF PAYMENT:

THE BUTT JOINT WILL BE PAID FOR AT THE CONTRACT UNIT PRICE PER SQUARE YARD (SQUARE METER) FOR "HOT-MIX ASPHALT SURFACE REMOVAL - BUTT JOINT" OR FOR "PORTLAND CEMENT CONCRETE SURFACE REMOVAL - BUTT JOINT".

ALL DIMENSIONS ARE IN INCHES (MILLIMETERS) UNLESS OTHERWISE SHOWN.

FILE NAME =	USER NAME =	DESIGNED -	REVISED -
W:\cbstst01\22x34\bd32.dgn	gaglianob	M. DE YONG	R. SHAH 10-25-94
		DRAWN -	REVISED -
		A. ABBAS 03-21-97	
		CHECKED -	REVISED -
		M. GOMEZ 04-06-01	
		DATE -	REVISED -
		06-13-90	R. BORO 01-01-07

STATE OF ILLINOIS DEPARTMENT OF TRANSPORTATION

BUTT JOINT AND HMA TAPER DETAILS

SCALE: NONE	SHEET NO. 1 OF 1 SHEETS	STA. TO STA.	F.A. RTE.	SECTION	COUNTY	TOTAL SHEETS	SHEET NO.
			BD400-05	BD32			
			CONTRACT NO.				
			FED. ROAD DIST. NO. 1 ILLINOIS		FED. AID PROJECT		

FILE NAME =	USER NAME =	DESIGNED	REVISED
D1353887-SHT-DET-06.DGN	molopez		
		DRAWN -	REVISED -
		BH	
		CHECKED -	REVISED -
		DW	
		DATE -	REVISED -
		03-28-2011	

FILE NAME =	USER NAME =	DESIGNED	REVISED
D1353887-SHT-DET-06.DGN	molopez		
		DRAWN -	REVISED -
		BH	
		CHECKED -	REVISED -
		DW	
		DATE -	REVISED -
		03-28-2011	

STATE OF ILLINOIS DEPARTMENT OF TRANSPORTATION

VILLAGE OF BURR RIDGE JOLIET RD AT MADISON ST MISCELLANEOUS DETAILS

SCALE:	SHEET NO. OF SHEETS	STA. TO STA.	F.A.U RTE.	SECTION	COUNTY	TOTAL SHEETS	SHEET NO.
			2674	06-00034-00-PV		69	54
			CONTRACT NO. 63581				
			FED. ROAD DIST. NO. ILLINOIS		FED. AID PROJECT		