

PLAN
(For skews $\leq 30^\circ$)

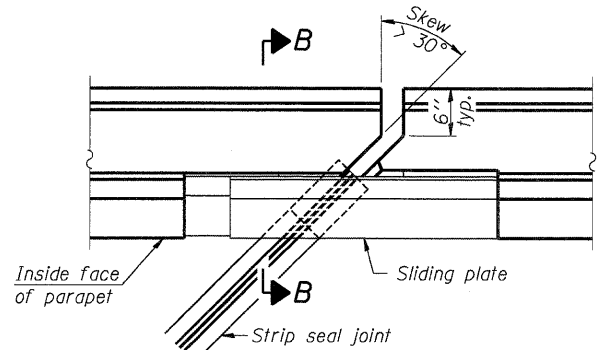

PLAN
(For skews $> 30^\circ$) Showing point block West Parapet - North Abutment only

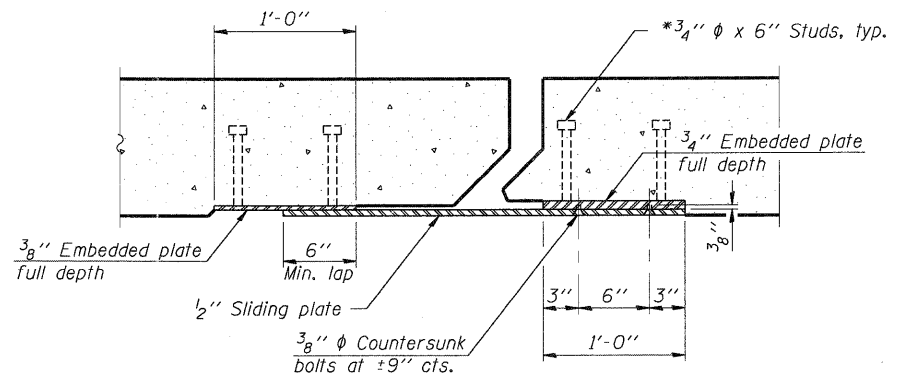

SECTION C-C

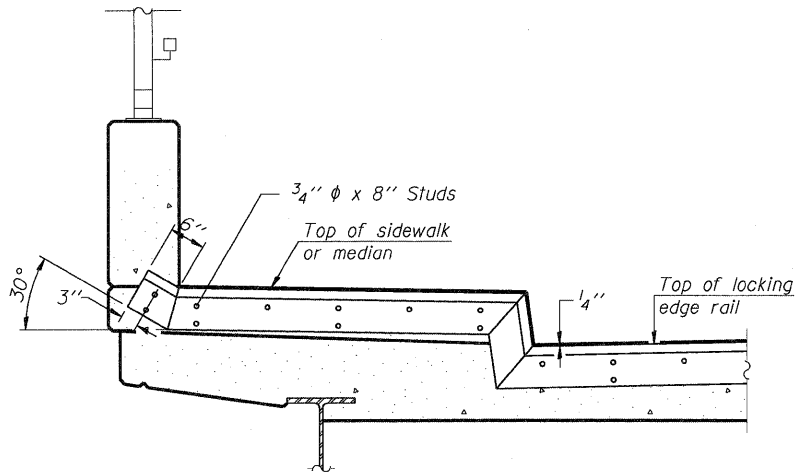

TYPICAL END TREATMENT AT SIDEWALK OR MEDIAN

Shorter plates with a single row of studs at 12" cts. may be necessary on medians which are shallower than 9". See manufacturer's recommendation.

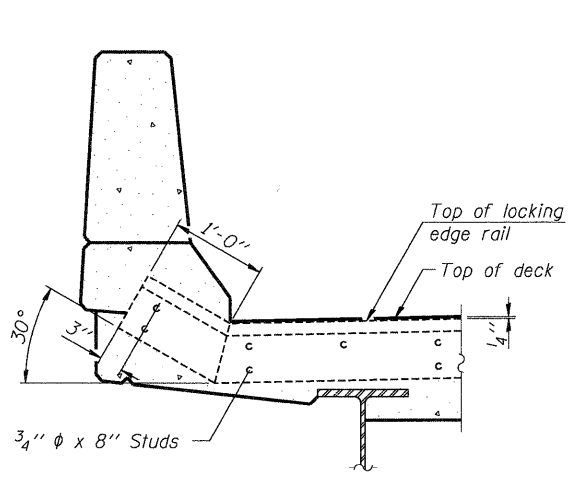

SECTION A-A

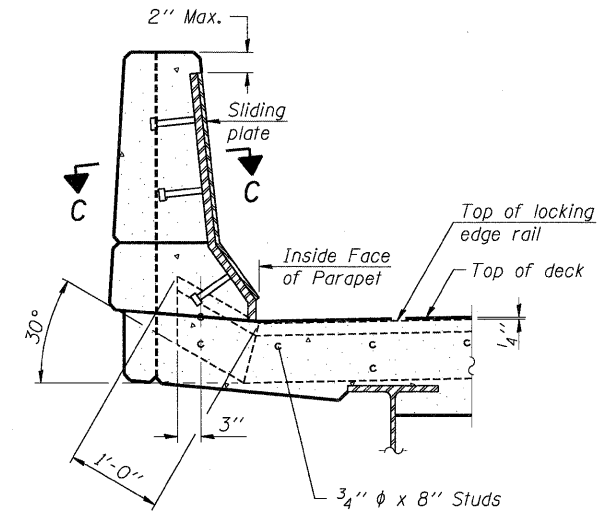

SECTION B-B

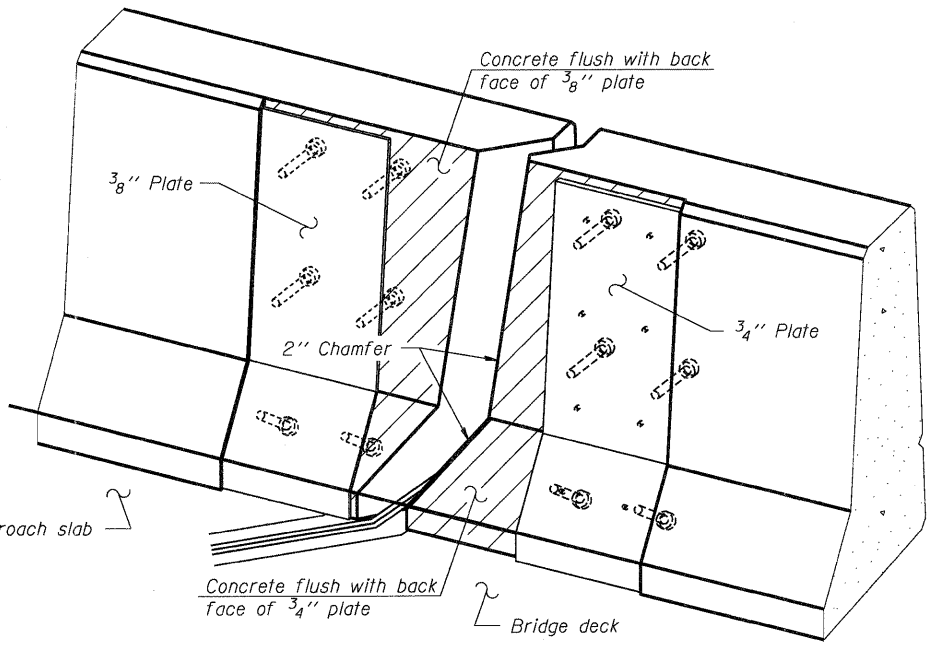

TRIMETRIC VIEW
(Showing back plates only)

Notes:

The strip seal shall be made continuous and shall have a minimum thickness of 1/4". The configuration of the strip seal shall match the configuration of the Locking Edge Rails. Open or "webbed" strip seal gland configurations are not permitted. The gland shall be sized for a maximum rated movement of 4 inches.

The Locking Edge Rails depicted are conceptual only, except for the minimum dimensions shown. The actual configuration of the Locking Edge Rails and matching strip seal may vary from manufacturer to manufacturer. Flanged edge rails will not be allowed. Locking Edge Rails may be spliced at slope discontinuities.

The manufacturer's recommended installation methods shall be followed.

The joint opening and deck dimensions detailed on the superstructure are based on a rolled rail expansion joint. If the Contractor elects to use the welded rail expansion joint, the opening and deck dimensions shall be modified according to the dimensions detailed on this sheet. Required modifications shall be made at no additional cost to the State.

All steel components shall be galvanized after fabrication according to Article 520.03 of the Standard Specifications.

Maximum space between rail segments at stage lines shall be 3/16", sealed with a suitable sealant.

Parapet plates and anchorage studs for skews > 30 degrees included in the cost of Preformed Joint Strip Seal.

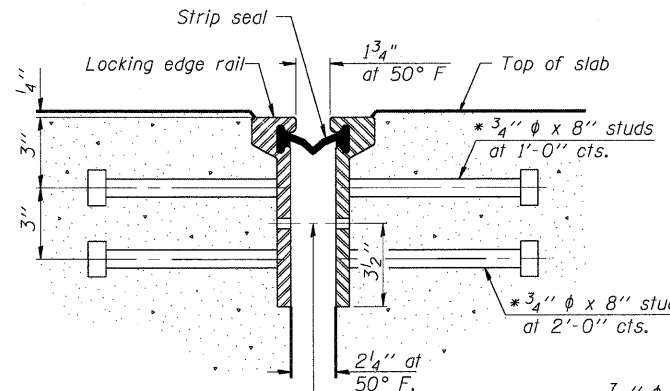

SECTION THRU ROLLED RAIL JOINT

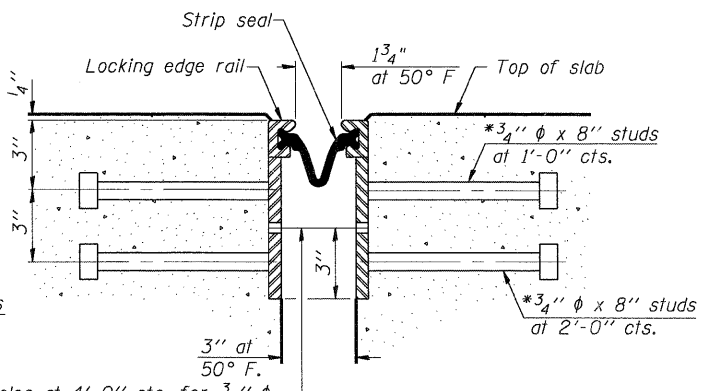

SECTION THRU WELDED RAIL JOINT

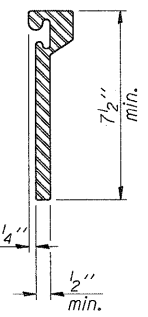

ROLLED EXTRUDED RAIL

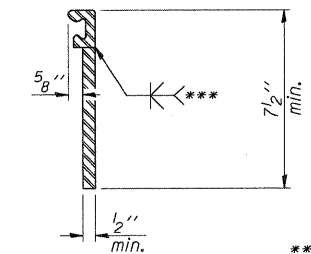

WELDED RAIL

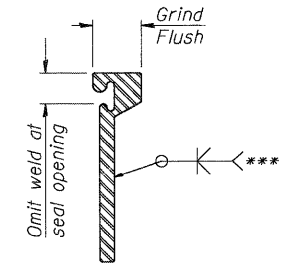

LOCKING EDGE RAIL SPLICE

The inside of the locking edge rail groove shall be free of weld residue. Rolled rail shown, welded rail similar.

*** Back gouge not required if complete joint penetration is verified by mock-up.

LOCKING EDGE RAILS

BILL OF MATERIAL

Item	Unit	Total
Preformed Joint Strip Seal	Foot	141

* Granular or solid flux filled headed studs conforming to Article 1006.32 of the Std. Specs., automatically end welded.

EJ-SSJ

7-1-10

10/20/10 CONN-99-001 E.D.G. NEWMARKO \S-0044\VAL\J.D. TRAVIS 87-2202-20668-001\STRUCT\CONV\01 DESIGN\0820329\SHEET 0820329-CONV-10-001-SHT-ELJ.DD

FILE NAME =	USER NAME = \$USER\$	DESIGNED - TCG	REVISED -	STATE OF ILLINOIS DEPARTMENT OF TRANSPORTATION IL 3 OVER TRRA & ST. CLAIR AVENUE	EXPANSION JOINT DETAILS SCALE: SHEET NO. SB-22 OF SB-63 STA. 1679+16.65 TO STA.			F.A.P. RTE.	SECTION	COUNTY	TOTAL SHEETS	SHEET NO.
#FILE#	PLOT SCALE = \$SCALE\$	DRAWN - TCG	REVISED -					998	82-2-IHVB-1	ST. CLAIR	345	214
TENG	PLOT DATE = \$DATE\$	CHECKED - JLR	REVISED -					SN 082-0329		CONTRACT NO. 76D05		
TENG & ASSOCIATES, INC. ENGINEERS/ARCHITECTS/PLANNERS CHICAGO, ILLINOIS	DATE - 05/13/11	REVISED -						FED. ROAD DIST. NO.	ILLINOIS FED. AID PROJECT			