

**PARTIAL FRAMING PLAN (SPANS 1 THRU 3)**

Notes: All skew lines are 30° to centerline of roadway.  
 All skew lines intersect diaphragms at mid-point between girders  
 Diaphragm and Field Splice spacing are along the centerline of roadway.

\*Typical dimension for 7'-3" girder spacing.

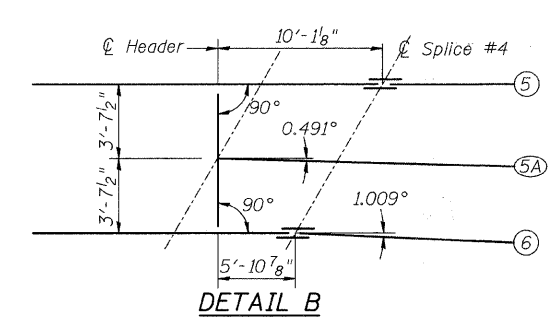
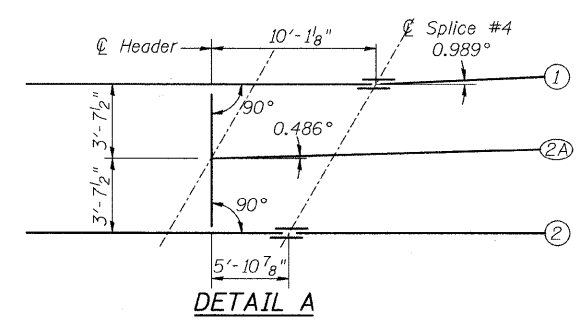

DESIGNED	JOH
CHECKED	BAN
DRAWN	TC
CHECKED	JOH

**FRAMING PLAN - SPANS 1 THRU 3  
 STRUCTURE NO. 099-4105**

SHEET NO. 29 60 SHEETS	RTE.	SECTION	COUNTY	TOTAL SHEETS	SHEET NO.
	TR 55	90-16103-01-BR	WILL	255	173
	SN 099-4105		CONTRACT NO. 83126		
FED. ROAD DIST. NO. 7 ILLINOIS			FED. AID PROJECT BRS-		