

**LOCATION 1 – US 45/2**

WILL COUNTY LINE TO MANTENO RD

MIX DESIGN - ALL LOCATIONS					
MIX	PG GRADE	DESIGN AIR VOIDS	MIX COMPOSITION	FRICTION AGG	DENSITY CONTROL
HMA SURFACE	PG 64-22	4.0% @N70	IL 9.5	MIXTURE D	CORES

**SEE SCHEDULES FOR WIDTHS AND LOCATIONS OF MILLING AND RESURFACING**

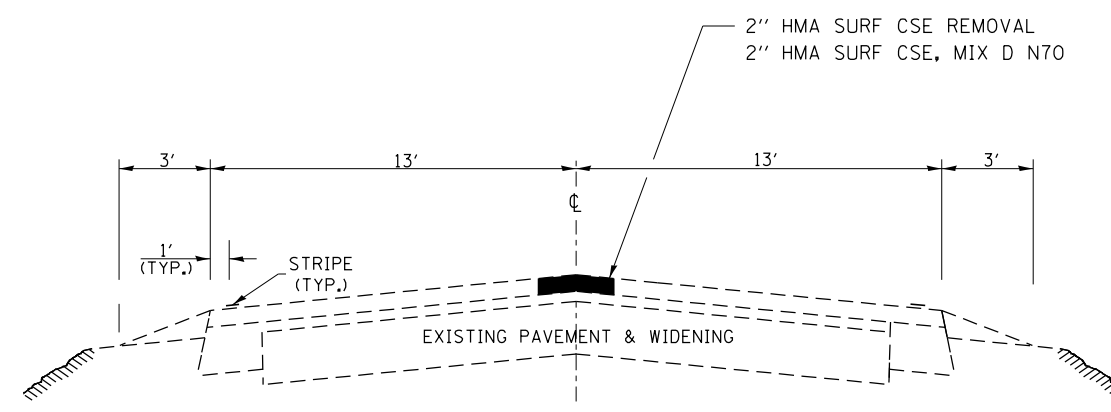

**LOCATION 2 – IL 114**

IL 1/17 TO INDIANA STATE LINE

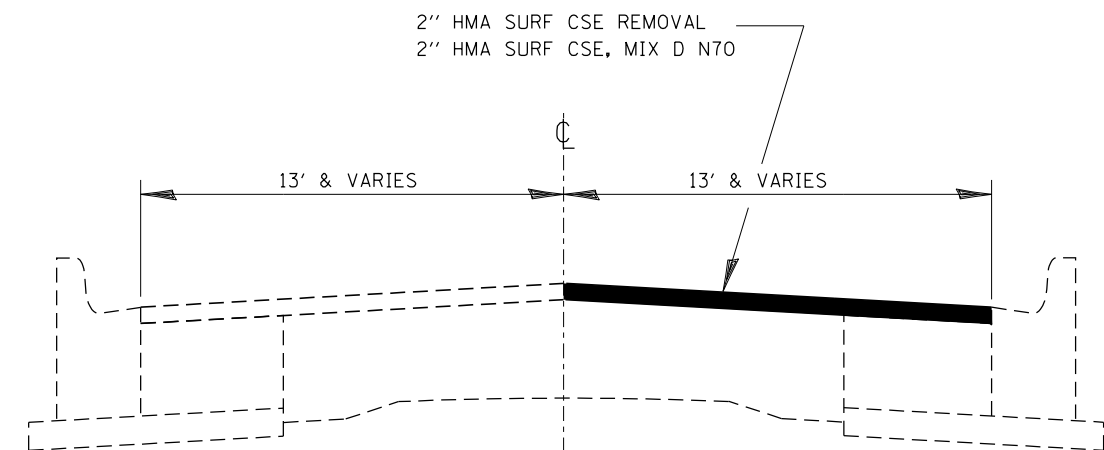

**LOCATION 2 – IL 114**

IL 1/17 TO INDIANA STATE LINE

• INTERMITTENT SPRING ROAD REPAIR 2014-6

FILE NAME =	USER NAME = carpenterdj	DESIGNED -	REVISED -
c:\pwork\pwork\carpenterdj\d0387881\03xxxxx-shr-typicol.dgn		DRAWN -	REVISED -
	PLOT SCALE = 100.0000' / in.	CHECKED -	REVISED -
\$MODELNAME\$	PLOT DATE = 6/25/2014	DATE -	REVISED -

**STATE OF ILLINOIS  
DEPARTMENT OF TRANSPORTATION**

**TYPICAL SECTIONS**

SCALE: SHEET OF SHEETS STA. TO STA.

F.A.P. RTE.	SECTION	COUNTY	TOTAL SHEETS	SHEET NO.
VAR	•	KANKAKEE	10	5
CONTRACT NO. 66D91				
ILLINOIS FED. AID PROJECT				