

MILLED TEMPORARY RAMP  
(FOR BUTT JOINT AND HMA TAPER SEE DETAIL BELOW)

OPTION 1

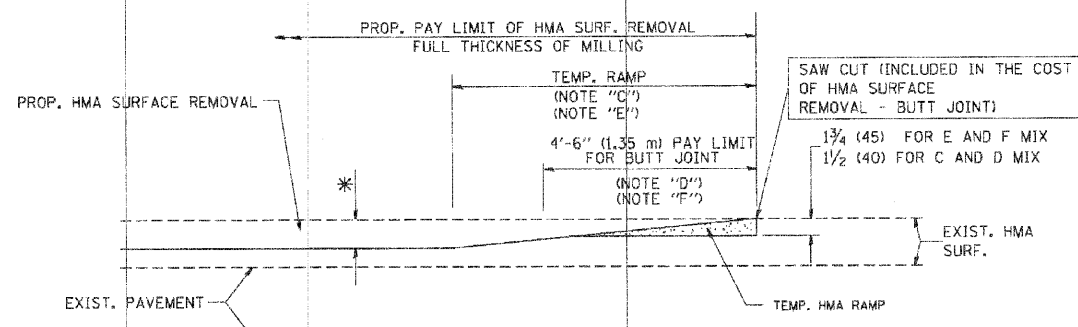

HMA CONSTRUCTED TEMPORARY RAMP  
(FOR BUTT JOINT AND HMA TAPER SEE DETAIL BELOW)

OPTION 2  
TYPICAL TEMPORARY RAMP

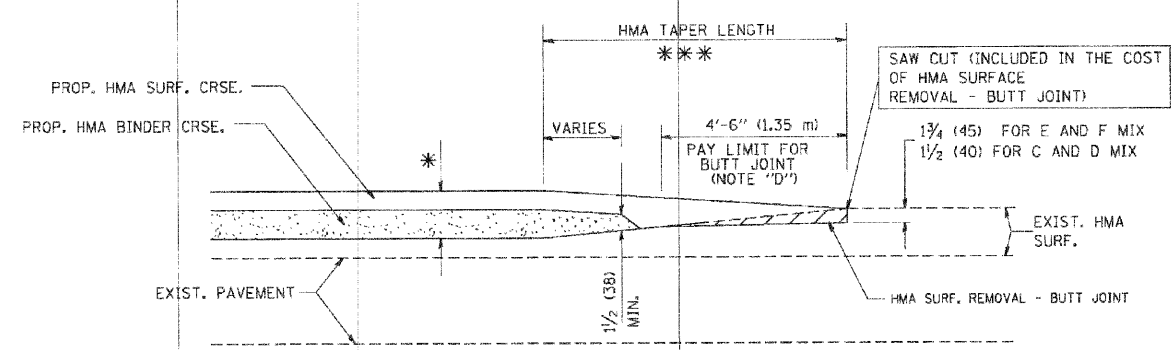

BUTT JOINT AND  
HMA TAPER

TYPICAL BUTT JOINT AND HMA TAPER  
FOR MILLING AND RESURFACING

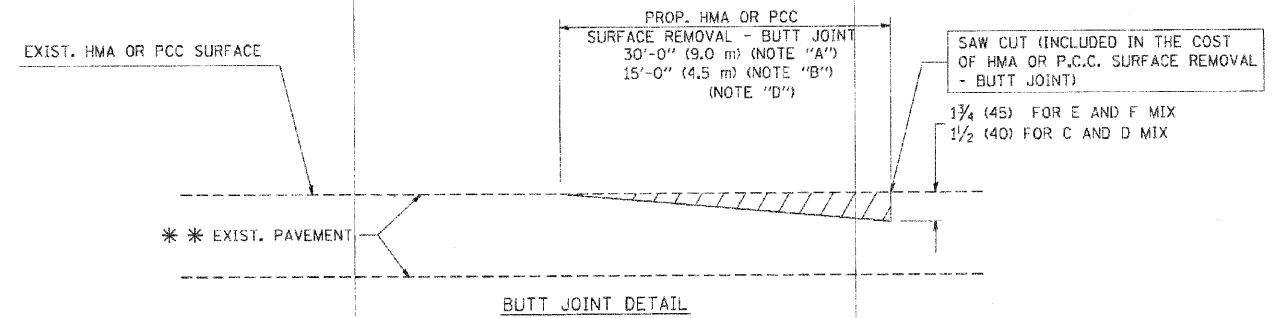

BUTT JOINT DETAIL

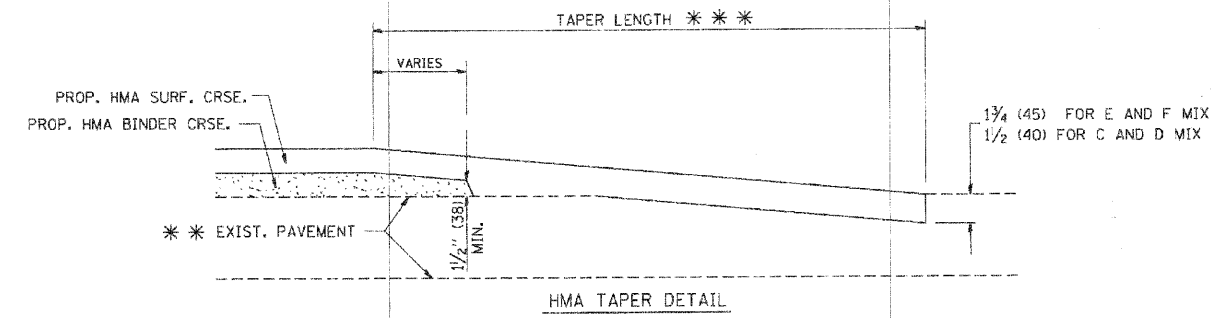

HMA TAPER DETAIL

TYPICAL BUTT JOINT AND HMA TAPER  
FOR RESURFACING ONLY

\*\*\* PC CONCRETE, HMA OR HMA RESURFACED PAVEMENT.

NOTES

- A: MAINLINE ROADWAYS AND MAJOR SIDE ROADS.
  - B: MINOR SIDE ROADS.
  - C: THE TEMP. RAMP SHALL BE CONSTRUCTED IMMEDIATELY UPON REMOVAL OF THE EXISTING HMA SURFACE.
  - D: THE BUTT JOINT SHALL BE CONSTRUCTED IMMEDIATELY PRIOR TO PLACING THE PROPOSED HMA COURSES.
  - E: TAPER THE TEMP. RAMP AT A RATE OF 3'-0" (900 mm) PER 1 INCH (25 mm) OF MILLING THICKNESS.
  - F: INSTALLATION AND REMOVAL OF THE 4'-6" (1.35 m) TEMP. RAMP IS INCLUDED IN COST OF HMA SURFACE REMOVAL - BUTT JOINT
  - G: SEE ARTICLE 406.08 AND 406.14 OF THE STANDARD SPECIFICATIONS FOR "HMA AND/OR PCC SURFACE REMOVAL, BUTT JOINT".
- \* SEE TYPICAL SECTIONS FOR MILLING THICKNESS.
- \*\*\* 20'-0" (6.1 m) PER 1 (25) RESURFACING (NOTE "A")  
10'-0" (3.0 m) PER 1 (25) RESURFACING (NOTE "B")

BASIS OF PAYMENT:

THE BUTT JOINT WILL BE PAID FOR AT THE CONTRACT UNIT PRICE PER SQUARE YARD (SQUARE METER) FOR "HOT-MIX ASPHALT SURFACE REMOVAL - BUTT JOINT" OR FOR "PORTLAND CEMENT CONCRETE SURFACE REMOVAL - BUTT JOINT".

ALL DIMENSIONS ARE IN INCHES (MILLIMETERS) UNLESS OTHERWISE SHOWN.

COPYRIGHT © 2010 ENGINEERING ENTERPRISES, INC.

FILE NAME =	USER NAME = goglienobts	DESIGNED - M. DE YONG	REVISED - R. SHAH 10-25-94
W:\projects\122\34\bd32.dgn		DRAWN -	REVISED - A. ABBAS 03-21-97
	PLOT SCALE = 50.2000' / IN.	CHECKED -	REVISED - M. GOWEZ 04-06-01
	PLOT DATE = 1/4/2009	DATE = 06-13-90	REVISED - R. BORO 01-01-07

STATE OF ILLINOIS  
DEPARTMENT OF TRANSPORTATION

SCALE: NONE	SHEET NO. 1 OF 1 SHEETS	STA. TO STA.
-------------	-------------------------	--------------

F.A.U. R.T.E.	SECTION	COUNTY	TOTAL SHEETS	SHEET NO.
3794	10-00048-00-BB	KENDALL	13	13
BD400-05 BD32		CONTRACT NO. 63498		
FED. ROAD DIST. NO. 1 ILLINOIS/FED. AID PROJECT				

Plotted: June 8, 2010 @ 3:42 PM By: Larry Noon -- Tab: 13 BD-32 22x34

Path: \\SOS\PROJ\100930\DWG\DWG\_FINAL\_ENG\100930-01R