

STATE OF ILLINOIS  
DEPARTMENT OF TRANSPORTATION

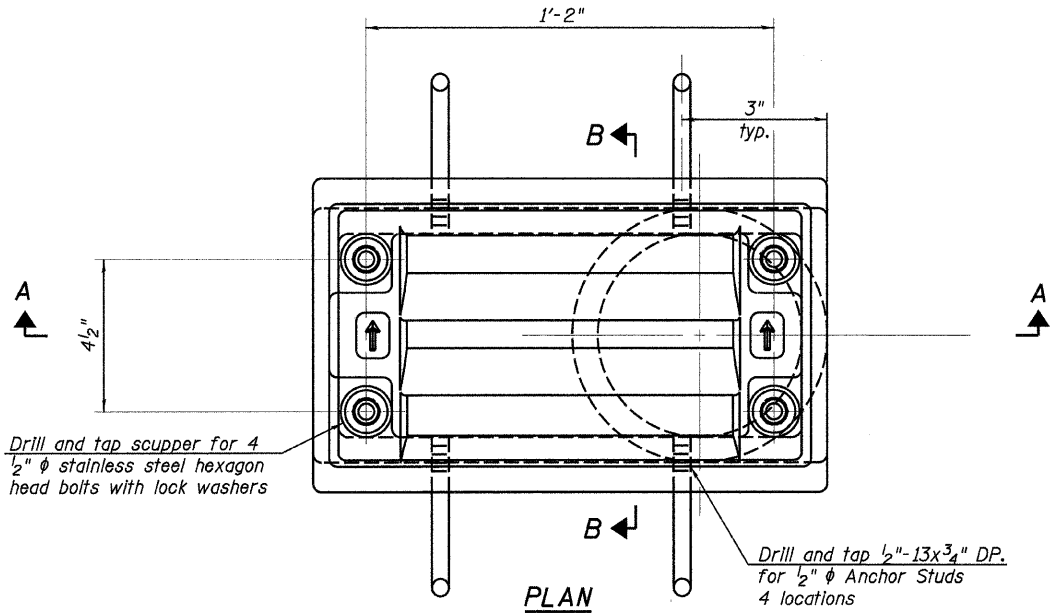

PLAN

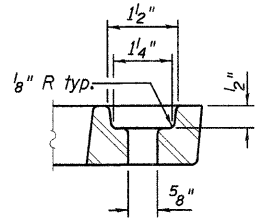
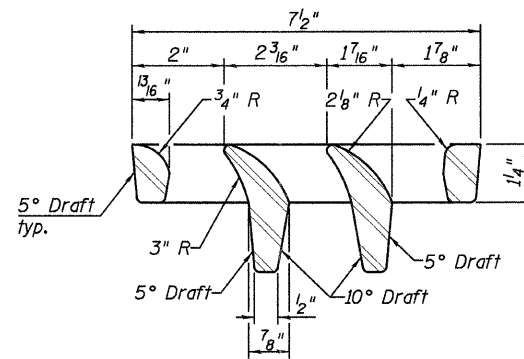

BOLT HOLE DETAIL

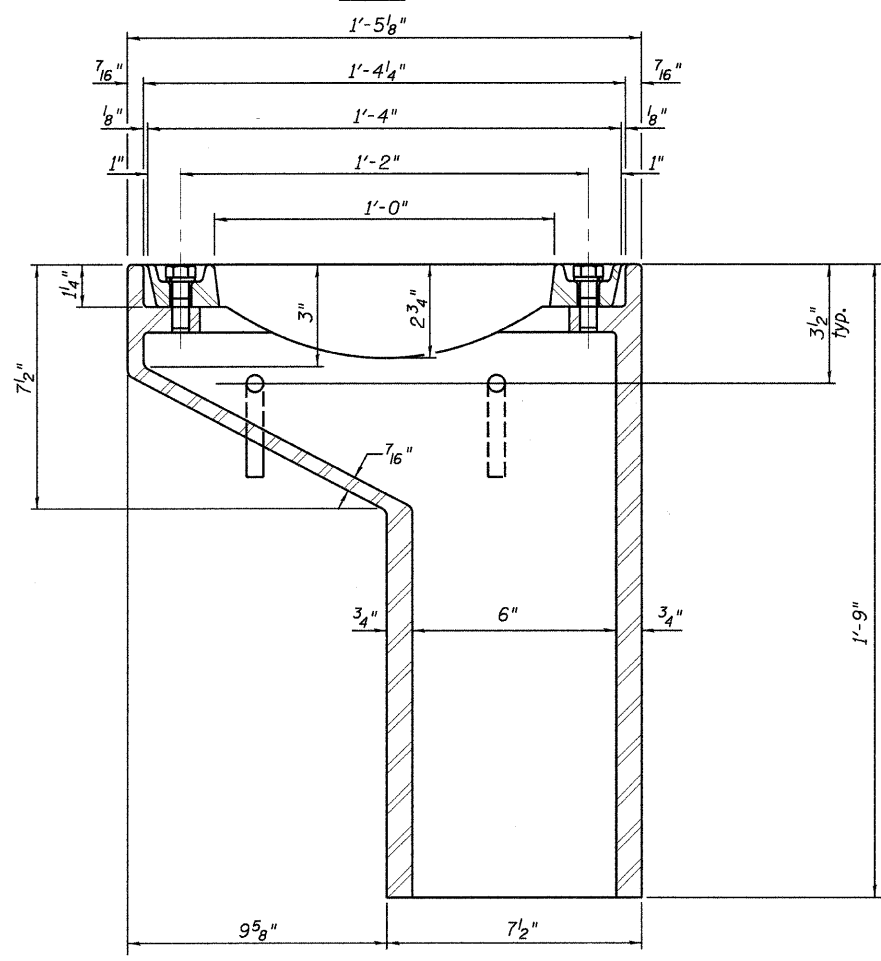

SECTION A-A

See sheet 14 for scupper location relative to parapet.

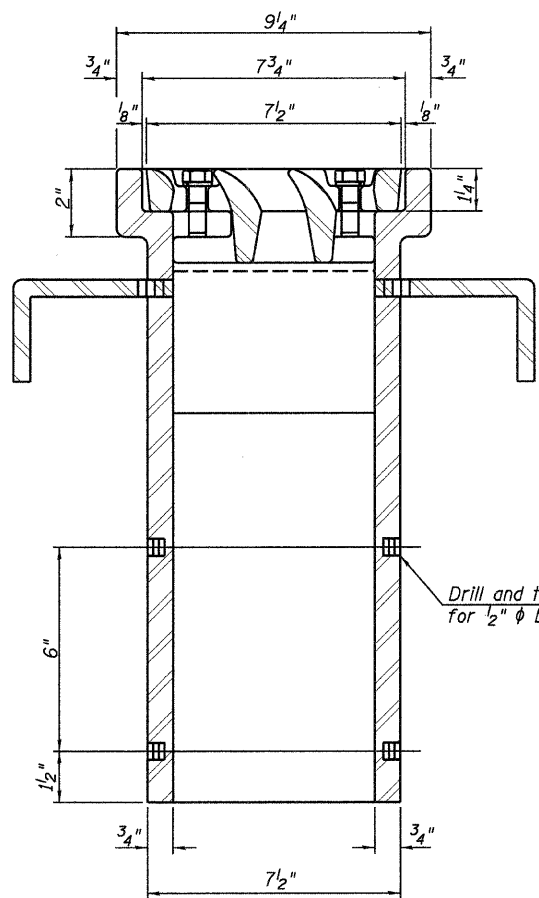

SECTION B-B

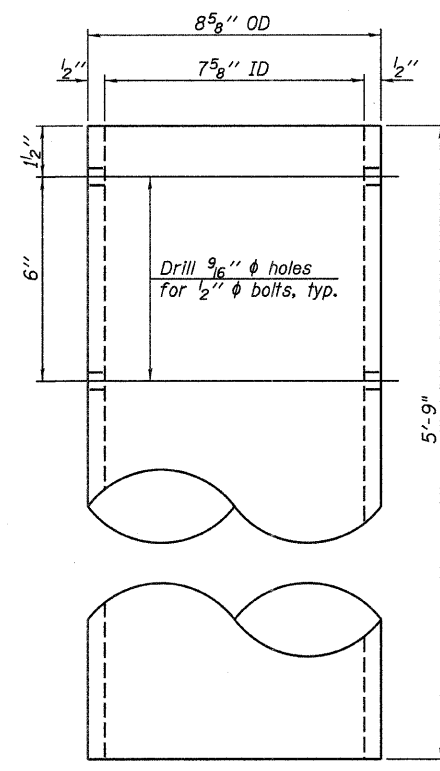

DOWNSPOUT

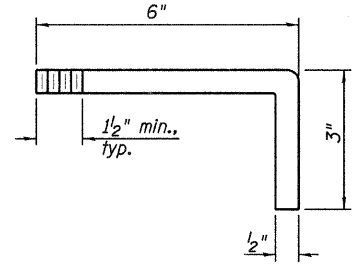

ANCHOR STUD DETAIL

BILL OF MATERIAL

ITEM	UNIT	QUANTITY
Drainage Scupper, DS-11	Each	4

DRAINAGE SCUPPER, DS-11  
STRUCTURE NO. 032-0115

DESIGNED - CMM
CHECKED - JSD
DRAWN - GJS
CHECKED - JSD

DS-11 10-1-08

**LOCHNER**  
H.W. LOCHNER, INC.  
CONSULTING ENGINEERS & PLANNERS  
20 NORTH WACKER DRIVE SUITE 1200  
CHICAGO, IL 60606

SHEET NO. 18 OF 31 SHEETS	RTE.	SECTION	COUNTY	TOTAL SHEETS	SHEET NO.
	*	(32, 47-4) HBK-4 & (G)N	GRUNDY	351	300
	CONTRACT NO. 66408				
FED. ROAD DIST. NO. _ ILLINOIS FED. AID PROJECT					
* FAI 80 & FAS 297 / FAU 392					

T:\2608-br\1s\struc\0320058-66408-018-SP01.dgn