

* See Superstructure Details.

SECTION
(Showing dimensions)

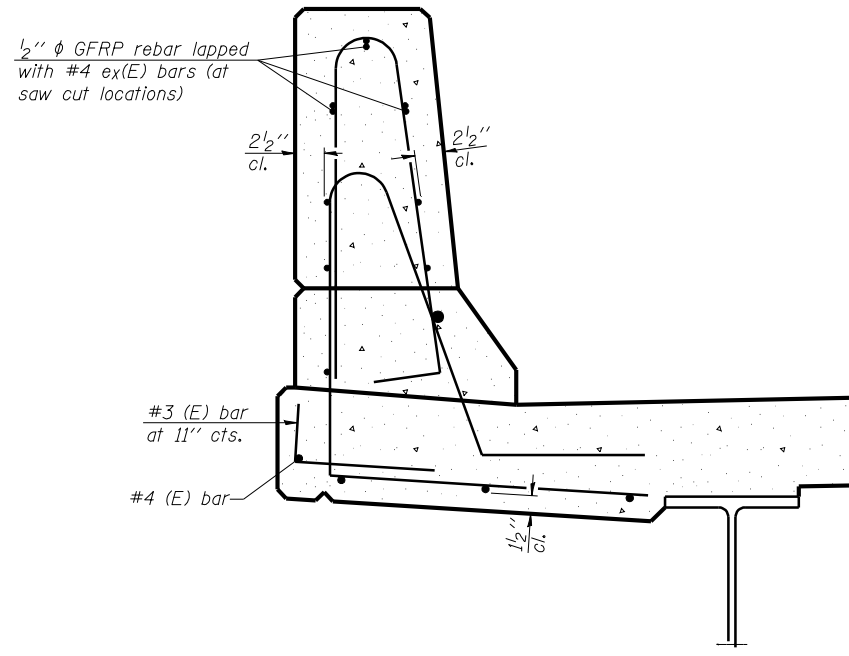

SECTION
(Showing reinforcement clearances for slip forming and additional reinforcement bars)

GENERAL NOTES
 All dimensions shall remain the same as shown on superstructure details, except dimensions A and B which are to be revised as shown to provide additional clearance. Additional concrete needed to revise dimension A and B = 0.0165 cu. yds./ft. of parapet.
 Place aluminum sheet in curb portion at and near piers. Full thickness saw cut at all joint locations in lieu of cork joint filler.
 Steel superstructure shown. Other superstructure types similar.

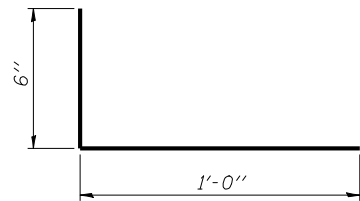

#3 (E) BAR

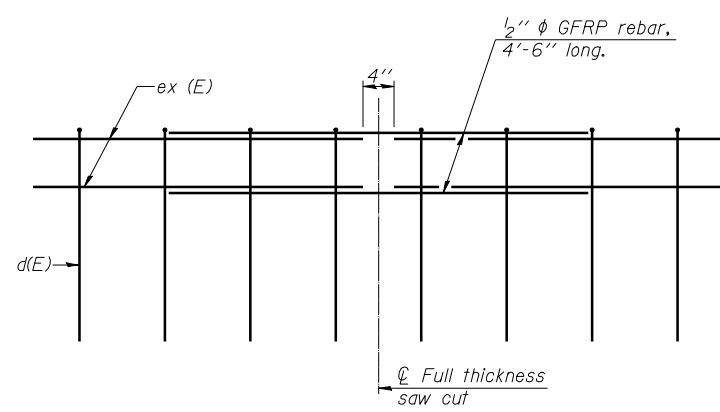

GFRP REBAR STIFFENING DETAIL
(Place as shown in parapet section at each parapet joint location.)

**CONCRETE PARAPET
SLIPFORMING OPTION
S.N. 084-0521**

F.A.P. RTE.	SECTION	COUNTY	TOTAL SHEETS	SHEET NO.
662	H(RS-10,B-2)	SANGAMON	84	72
CONTRACT NO. 72A73				
FED. ROAD DIST. NO.	ILLINOIS FED. AID PROJECT			