

LEGEND

	HOT-MIX ASPHALT SURFACE REMOVAL		COMBINATION CURB AND GUTTER REMOVAL OR GUTTER REMOVAL		APPROACH PAVEMENT REMOVAL
	PAVEMENT REMOVAL		PAVED SHOULDER REMOVAL		ISLAND REMOVAL
	DRIVEWAY PAVEMENT REMOVAL		MEDIAN SURFACE REMOVAL		
TREE REMOVAL (UNITS) X					

NOTE: DRAINAGE ITEM REMOVALS ARE INDICATED ON DRAINAGE SHEETS.

ALL BASELINES FOR EXISTING RAMPS PRESENTED ON THESE REMOVAL SHEETS ARE EXISTING ALIGNMENTS FOR CONTROL POINTS. SEE HORIZONTAL CONTROL SHEETS.

FILE NAME = S:\Projects\403-00072_51-70\dgn\Fayette\removal.plt	USER NAME = paul	DESIGNED - JWS	REVISED -	STATE OF ILLINOIS DEPARTMENT OF TRANSPORTATION	REMOVAL PLAN, FAYETTE AVENUE		F.A.I. RTE. 57/70	SECTION (25-3)I-6	COUNTY EFFINGHAM	TOTAL SHEETS 839	SHEET NO. 305	
PLOT SCALE = 40.0000' / IN.	CHECKED - BRM	DATE - 11-16-07	REVISED -		SCALE: 1"=20'	SHEET NO. 1 OF 20 SHEETS	STA. 32+71.37 TO STA. 36+25.00	CONTRACT NO. 74293				
PLOT DATE = 6/24/2010					FED. ROAD DIST. NO. ILLINOIS FED. AID PROJECT							

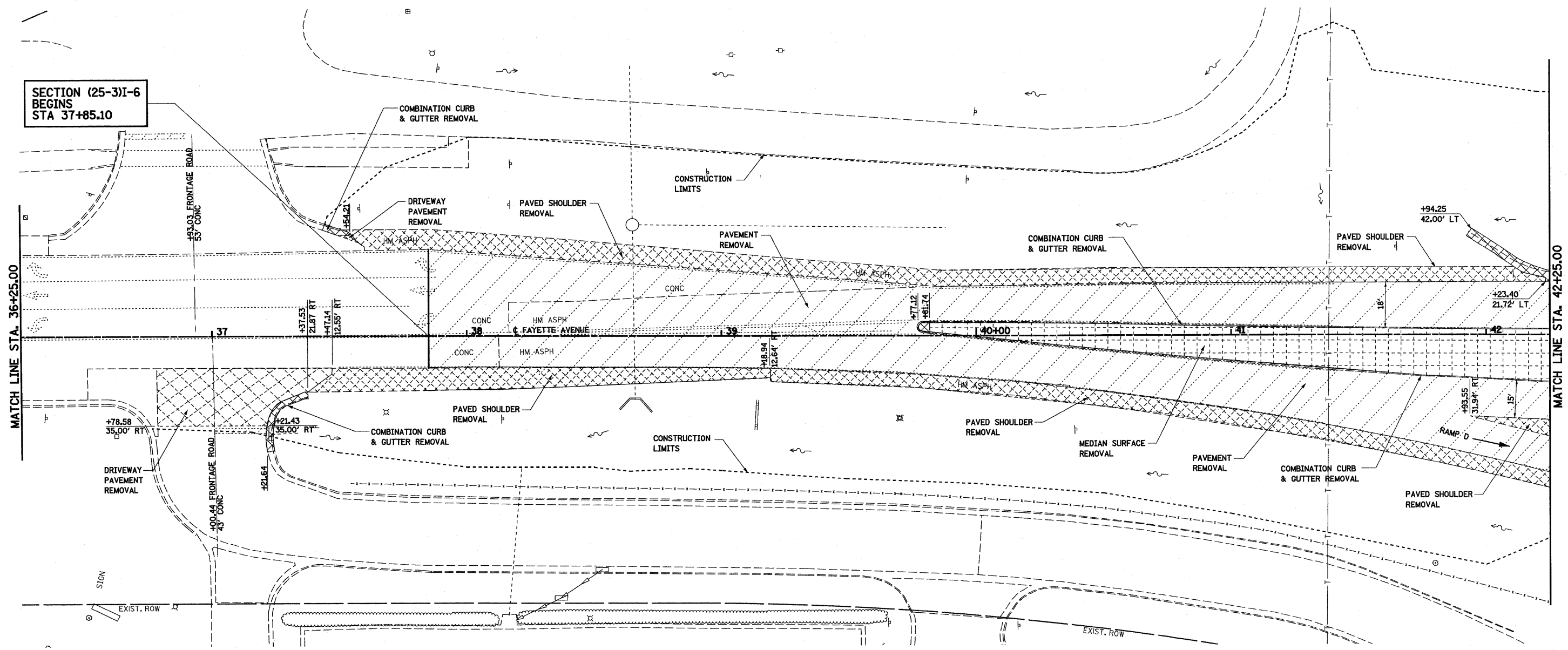

SECTION (25-3)I-6
BEGINS
STA 37+85.10

MATCH LINE STA. 36+25.00

MATCH LINE STA. 42+25.00

LEGEND



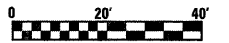

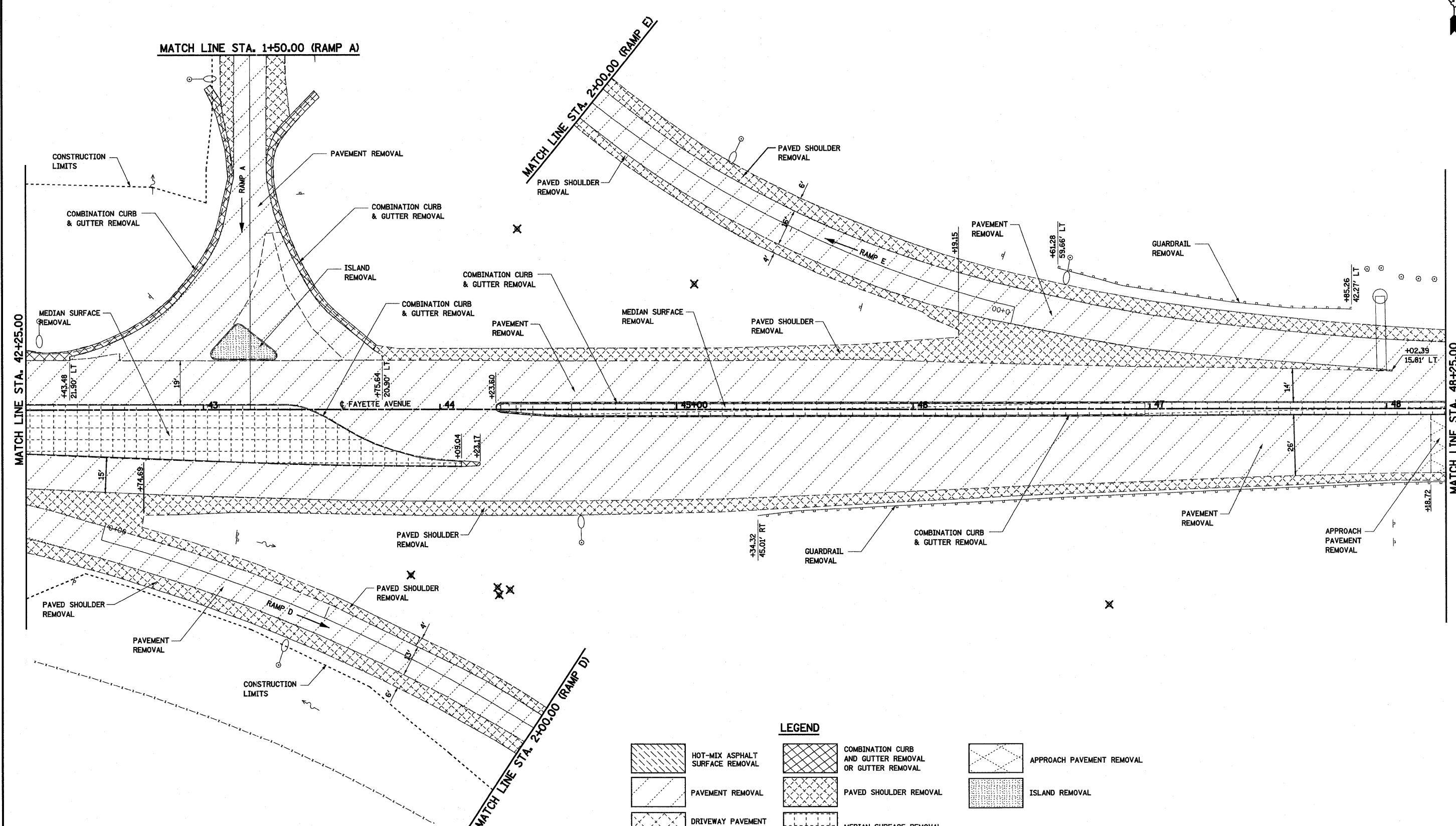

- HOT-MIX ASPHALT SURFACE REMOVAL
 - COMBINATION CURB AND GUTTER REMOVAL OR GUTTER REMOVAL
 - APPROACH PAVEMENT REMOVAL
 - PAVEMENT REMOVAL
 - PAVED SHOULDER REMOVAL
 - ISLAND REMOVAL
 - DRIVEWAY PAVEMENT REMOVAL
 - MEDIAN SURFACE REMOVAL
- TREE REMOVAL (UNITS) X



FILE NAME =	USER NAME = paul	DESIGNED - JWS	REVISED -	STATE OF ILLINOIS DEPARTMENT OF TRANSPORTATION	REMOVAL PLAN, FAYETTE AVENUE	F.A.T. RTE.	SECTION	COUNTY	TOTAL SHEETS	SHEET NO.		
S:\Projects\403-00072.51-70\dm\Fayette\Removal\plan.dgn						57/70	(25-3)I-6	EFFINGHAM	839	306		
PLOT SCALE = 40.0000' / IN.						CONTRACT NO. 74293						
PLOT DATE = 6/24/2010				DATE - 11-16-07	REVISED -	SCALE:		SHEET NO. 2 OF 20 SHEETS		STA. 36+25.00 TO STA. 42+25.00	FED. ROAD DIST. NO.	ILLINOIS FED. AID PROJECT

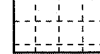

LEGEND

 HOT-MIX ASPHALT SURFACE REMOVAL	 COMBINATION CURB AND GUTTER REMOVAL OR GUTTER REMOVAL	 APPROACH PAVEMENT REMOVAL
 PAVEMENT REMOVAL	 PAVED SHOULDER REMOVAL	 ISLAND REMOVAL
 DRIVEWAY PAVEMENT REMOVAL	 MEDIAN SURFACE REMOVAL	
TREE REMOVAL (UNITS) X		

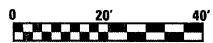

FILE NAME = S:\Projects\403-00072-57-70\gn\FayetteRemoval.pln	USER NAME = paul	DESIGNED - JWS	REVISED -
PLOT SCALE = 40.0000' / IN.	DRAWN - PDB	CHECKED - BRM	REVISED -
PLOT DATE = 6/24/2010	DATE - 11-16-07		REVISED -





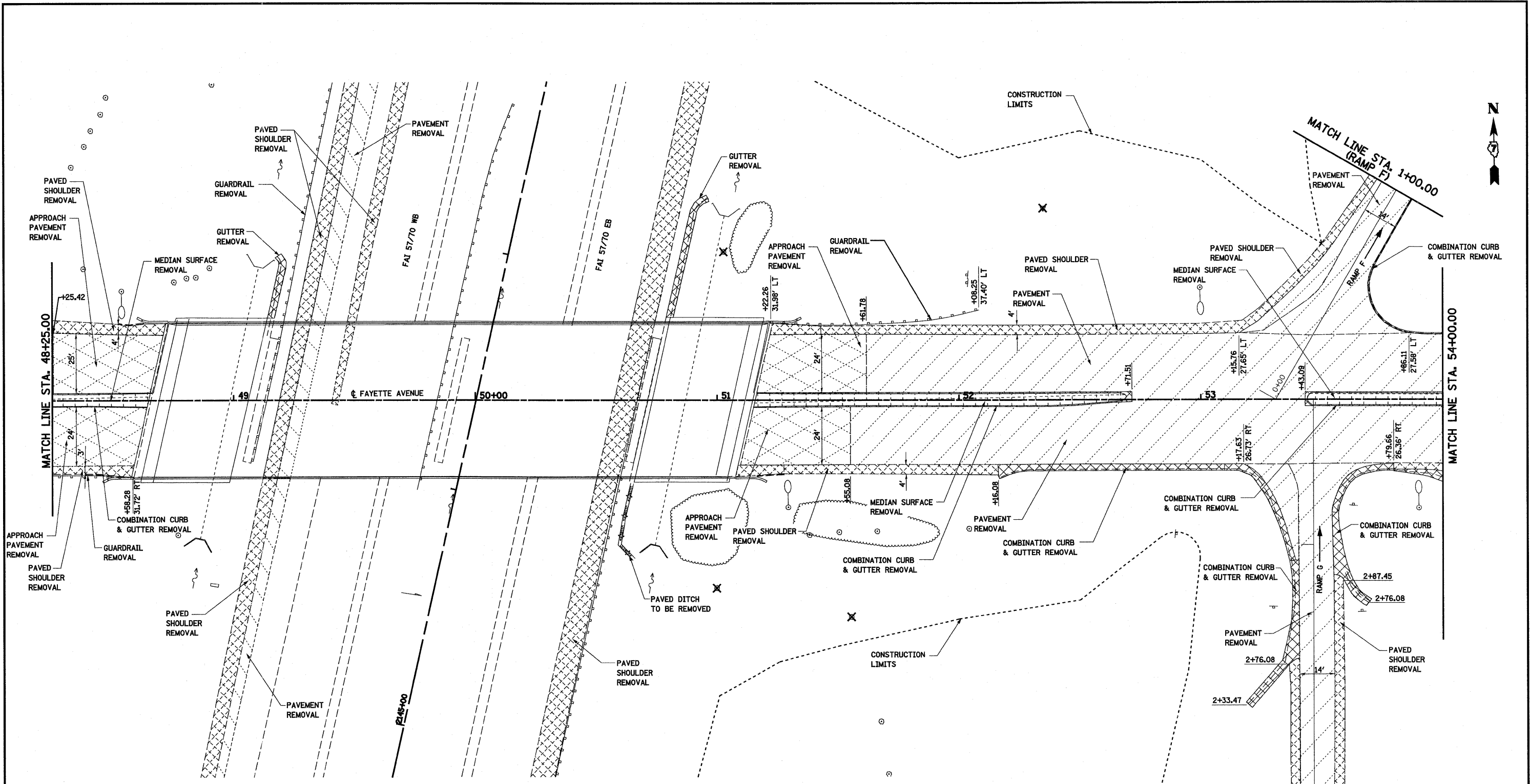

**STATE OF ILLINOIS
DEPARTMENT OF TRANSPORTATION**

REMOVAL PLAN, FAYETTE AVENUE
SCALE: 1"=20' SHEET NO. 3 OF 20 SHEETS STA. 42+25.00 TO STA. 48+25.00

F.A.I. RTE. 57/70	SECTION (25-3)-6	COUNTY EFFINGHAM	TOTAL SHEETS 839	SHEET NO. 307
CONTRACT NO. 74293				
FED. ROAD DIST. NO. ILLINOIS FED. AID PROJECT				

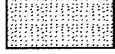

LEGEND

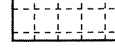

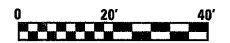

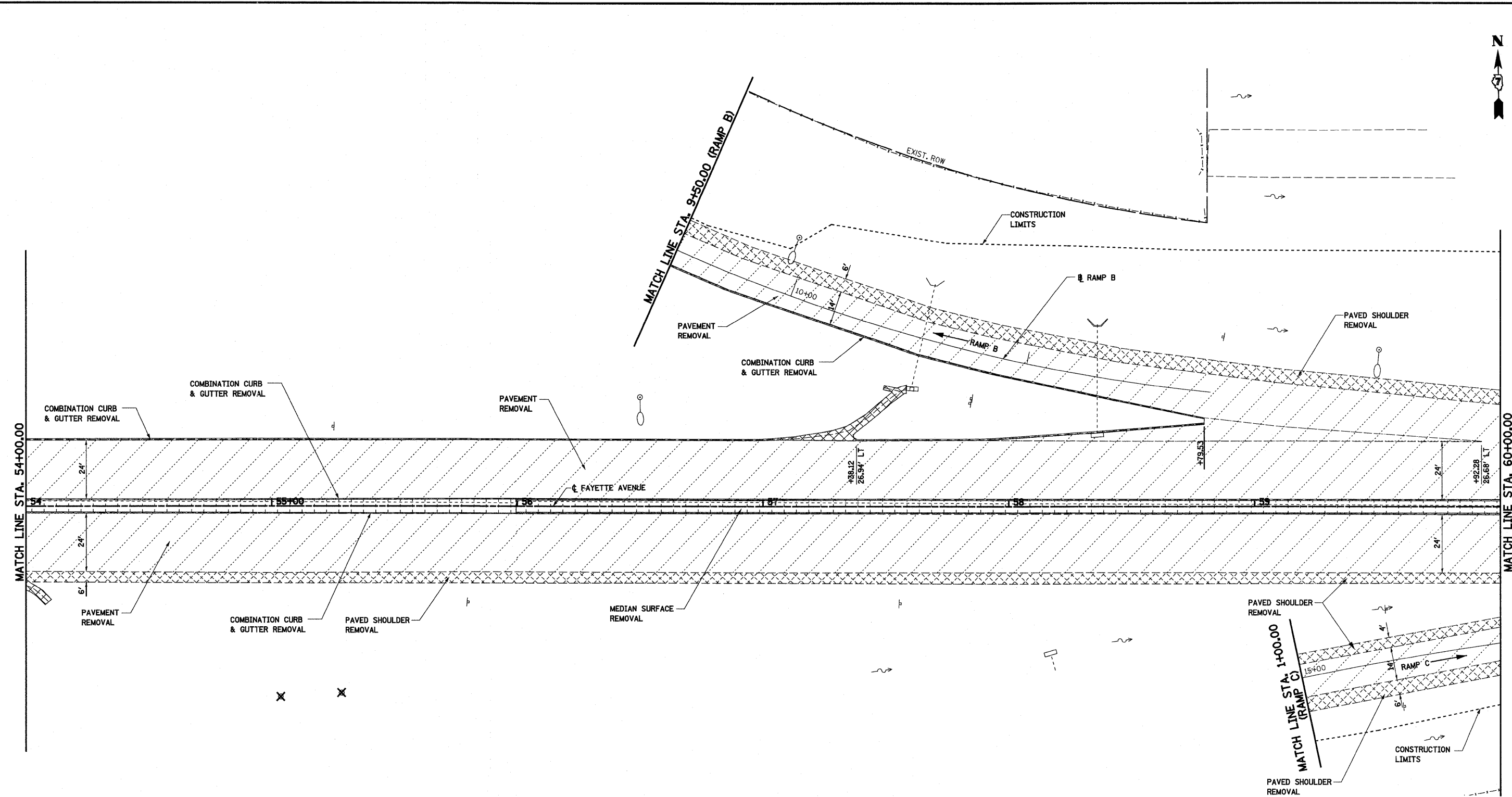

- | | | |
|---|---|---|
|  HOT-MIX ASPHALT SURFACE REMOVAL |  COMBINATION CURB AND GUTTER REMOVAL OR GUTTER REMOVAL |  APPROACH PAVEMENT REMOVAL |
|  PAVEMENT REMOVAL |  PAVED SHOULDER REMOVAL |  ISLAND REMOVAL |
|  DRIVEWAY PAVEMENT REMOVAL |  MEDIAN SURFACE REMOVAL | |
- TREE REMOVAL (UNITS) X

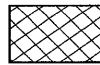

FILE NAME =	USER NAME = paul	DESIGNED - JWS	REVISED -	STATE OF ILLINOIS DEPARTMENT OF TRANSPORTATION	REMOVAL PLAN, FAYETTE AVENUE		F.A.I. RTE. 57/70	SECTION (25-3)I-6	COUNTY EFFINGHAM	TOTAL SHEETS 839	SHEET NO. 308	
S:\V\Projects\403-00072-57-70\sgn\FayetteRemoval.plt.dgn		DRAWN - PDB	REVISED -		SCALE: 1"=20'	SHEET NO. 4 OF 20 SHEETS	STA. 48+25.00 TO STA. 54+00.00	CONTRACT NO. 74293				
		CHECKED - BRM	REVISED -									
		DATE - 11-16-07	REVISED -									



LEGEND

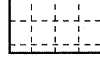

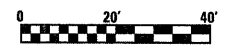

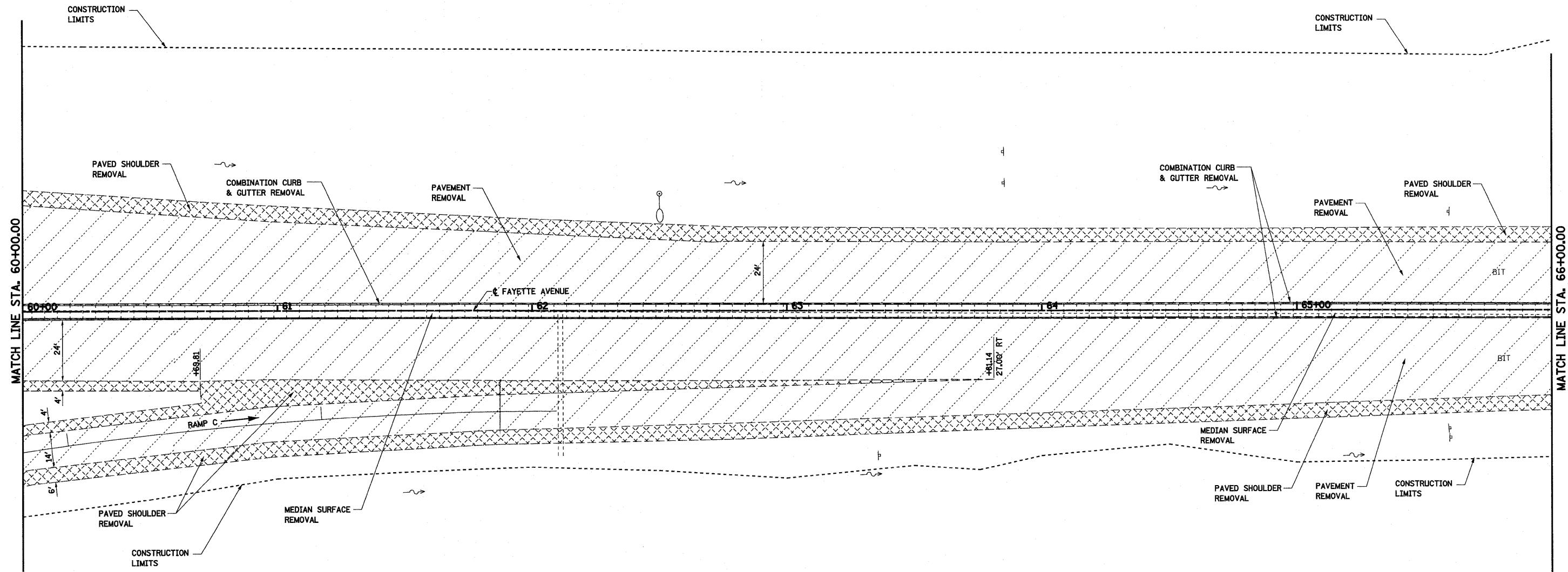

- | | | |
|---|---|---|
|  HOT-MIX ASPHALT SURFACE REMOVAL |  COMBINATION CURB AND GUTTER REMOVAL OR GUTTER REMOVAL |  APPROACH PAVEMENT REMOVAL |
|  PAVEMENT REMOVAL |  PAVED SHOULDER REMOVAL |  ISLAND REMOVAL |
|  DRIVEWAY PAVEMENT REMOVAL |  MEDIAN SURFACE REMOVAL | |
| TREE REMOVAL (UNITS) X | | |



FILE NAME = S:\Projects\403-00072-51-70\dm\Fayette\removal.plt	USER NAME = paul	DESIGNED - JWS	REVISED -	STATE OF ILLINOIS DEPARTMENT OF TRANSPORTATION	REMOVAL PLAN, FAYETTE AVENUE			F.A.I. RTE. 57/70	SECTION (25-3)I-6	COUNTY EFFINGHAM	TOTAL SHEETS 839	SHEET NO. 309			
PLOT SCALE = 40,0000' / IN.	CHECKED - BRM	DATE - 11-16-07	REVISED -					SCALE: 1"=20'	SHEET NO. 5 OF 20 SHEETS	STA. 54+00.00 TO STA. 60+00.00	CONTRACT NO. 74293				
PLOT DATE = 6/24/2010	DATE - 11-16-07	REVISED -						FED. ROAD DIST. NO. ILLINOIS FED. AID PROJECT							

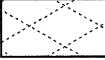
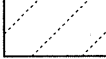

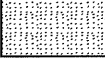
LEGEND

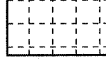
- | | | |
|---|---|---|
|  HOT-MIX ASPHALT SURFACE REMOVAL |  COMBINATION CURB AND GUTTER REMOVAL OR GUTTER REMOVAL |  APPROACH PAVEMENT REMOVAL |
|  PAVEMENT REMOVAL |  PAVED SHOULDER REMOVAL |  ISLAND REMOVAL |
|  DRIVEWAY PAVEMENT REMOVAL |  MEDIAN SURFACE REMOVAL | |
- TREE REMOVAL (UNITS) X

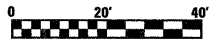

FILE NAME = S:\Projects\403-00072-51-70\dgn\Fayette\removal_plan.dgn	USER NAME = paul	DESIGNED - JWS	REVISED -	STATE OF ILLINOIS DEPARTMENT OF TRANSPORTATION	REMOVAL PLAN, FAYETTE AVENUE		F.A.I. RTE. 57/70	SECTION (25-3)I-6	COUNTY EFFINGHAM	TOTAL SHEETS 839	SHEET NO. 310			
PLOT SCALE = 40,0000' / IN.	DRAWN - PDB	CHECKED - BRM	REVISED -				SCALE: 1"=20'		SHEET NO. 6 OF 20 SHEETS		STA. 60+00.00 TO STA. 66+00.00		CONTRACT NO. 74293	
PLOT DATE = 5/24/2010	DATE - 11-16-07	REVISED -	REVISED -				FED. ROAD DIST. NO.		ILLINOIS FED. AID PROJECT					

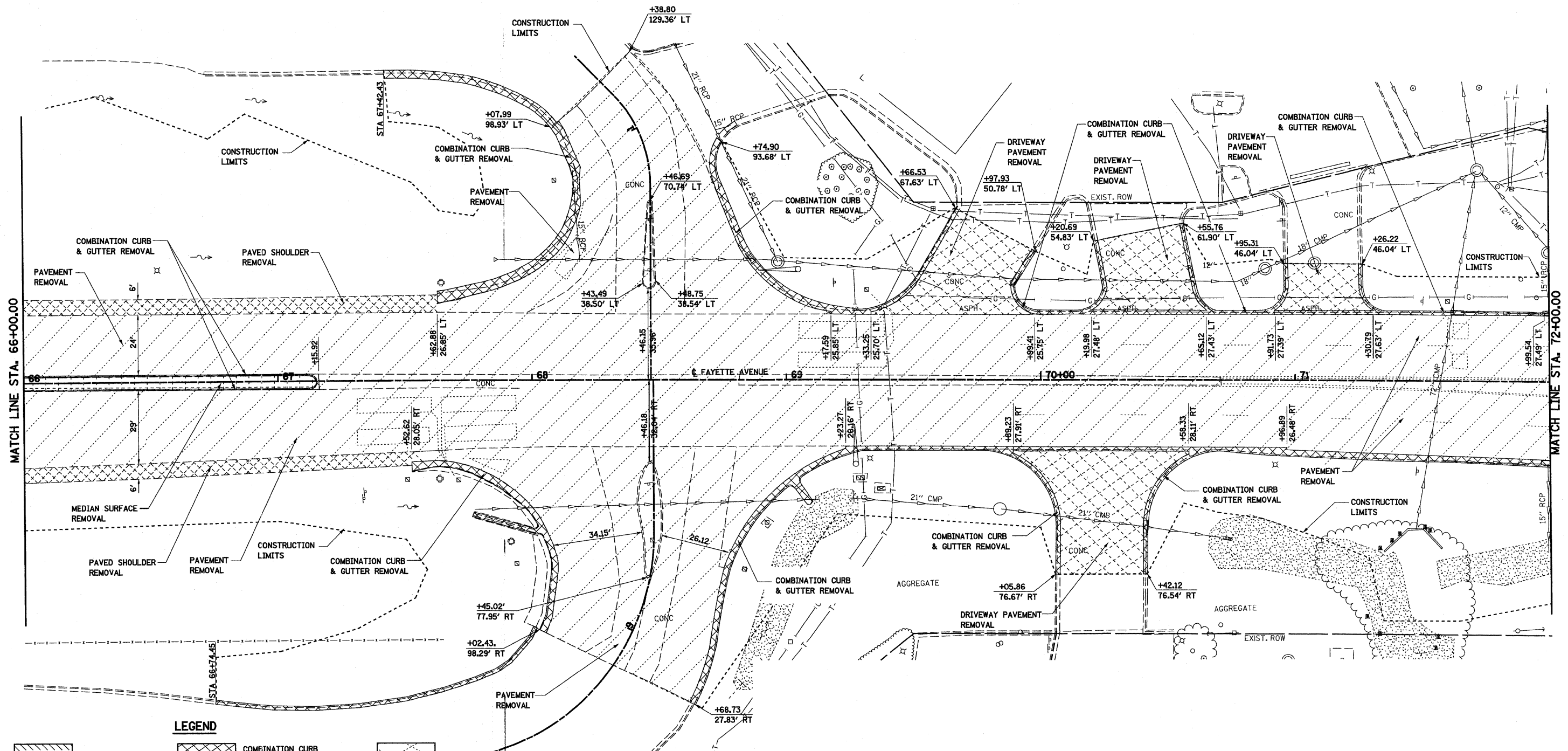

- HOT-MIX ASPHALT SURFACE REMOVAL
 - PAVEMENT REMOVAL
 - DRIVEWAY PAVEMENT REMOVAL
 - COMBINATION CURB AND GUTTER REMOVAL OR GUTTER REMOVAL
 - PAVED SHOULDER REMOVAL
 - MEDIAN SURFACE REMOVAL
 - APPROACH PAVEMENT REMOVAL
 - ISLAND REMOVAL
- TREE REMOVAL (UNITS) X

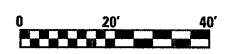



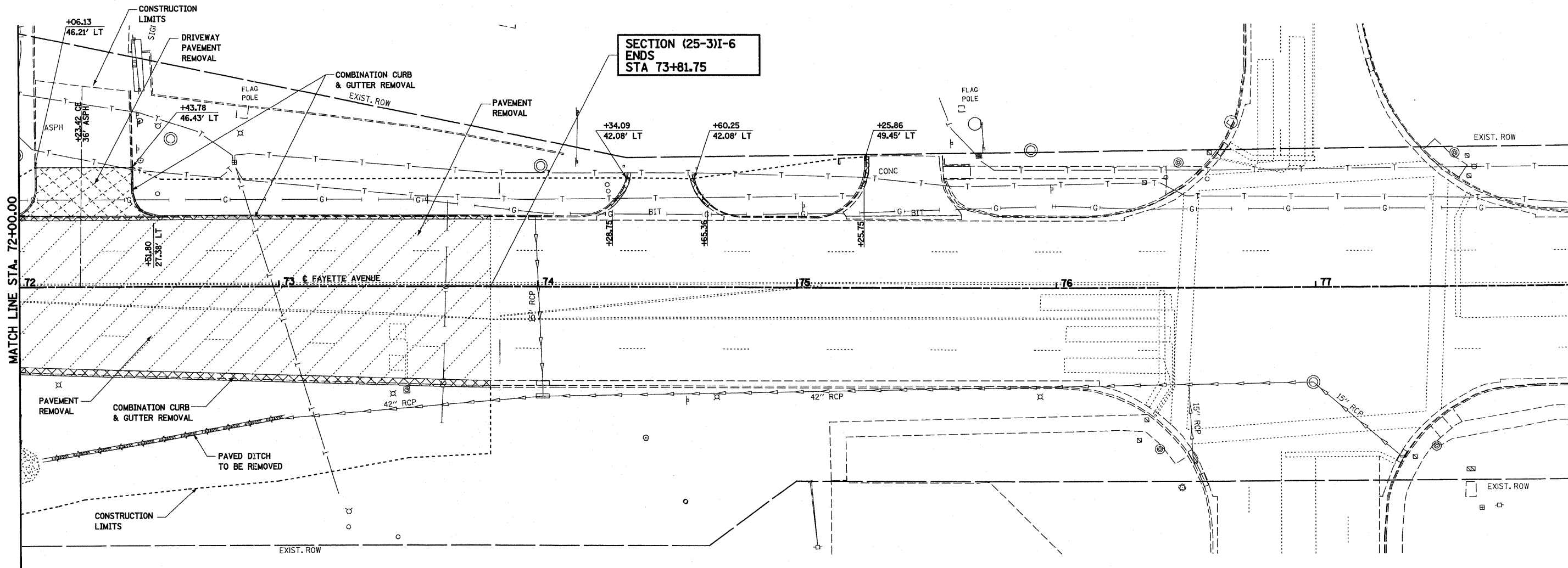



FILE NAME =	USER NAME = paul	DESIGNED - JWS	REVISED -	STATE OF ILLINOIS DEPARTMENT OF TRANSPORTATION	REMOVAL PLAN, FAYETTE AVENUE	F.A.I. RTE.	SECTION	COUNTY	TOTAL SHEETS	SHEET NO.		
S:\Projects\403-00072-51-70\dgn\FayetteRemoval.pln						57/70	(25-3)1-6	EFFINGHAM	839	311		
PLOT SCALE = 40,0000' / IN.						CONTRACT NO. 74293						
PLOT DATE = 6/24/2010						FED. ROAD DIST. NO. ILLINOIS FED. AID PROJECT						
DATE - 11-16-07				SCALE: 1"=20'		SHEET NO. 7 OF 20 SHEETS		STA. 66+00.00 TO STA. 72+00.00				

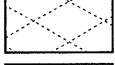

**SECTION (25-3)I-6
ENDS
STA 73+81.75**

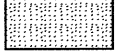
LEGEND



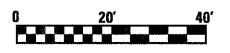

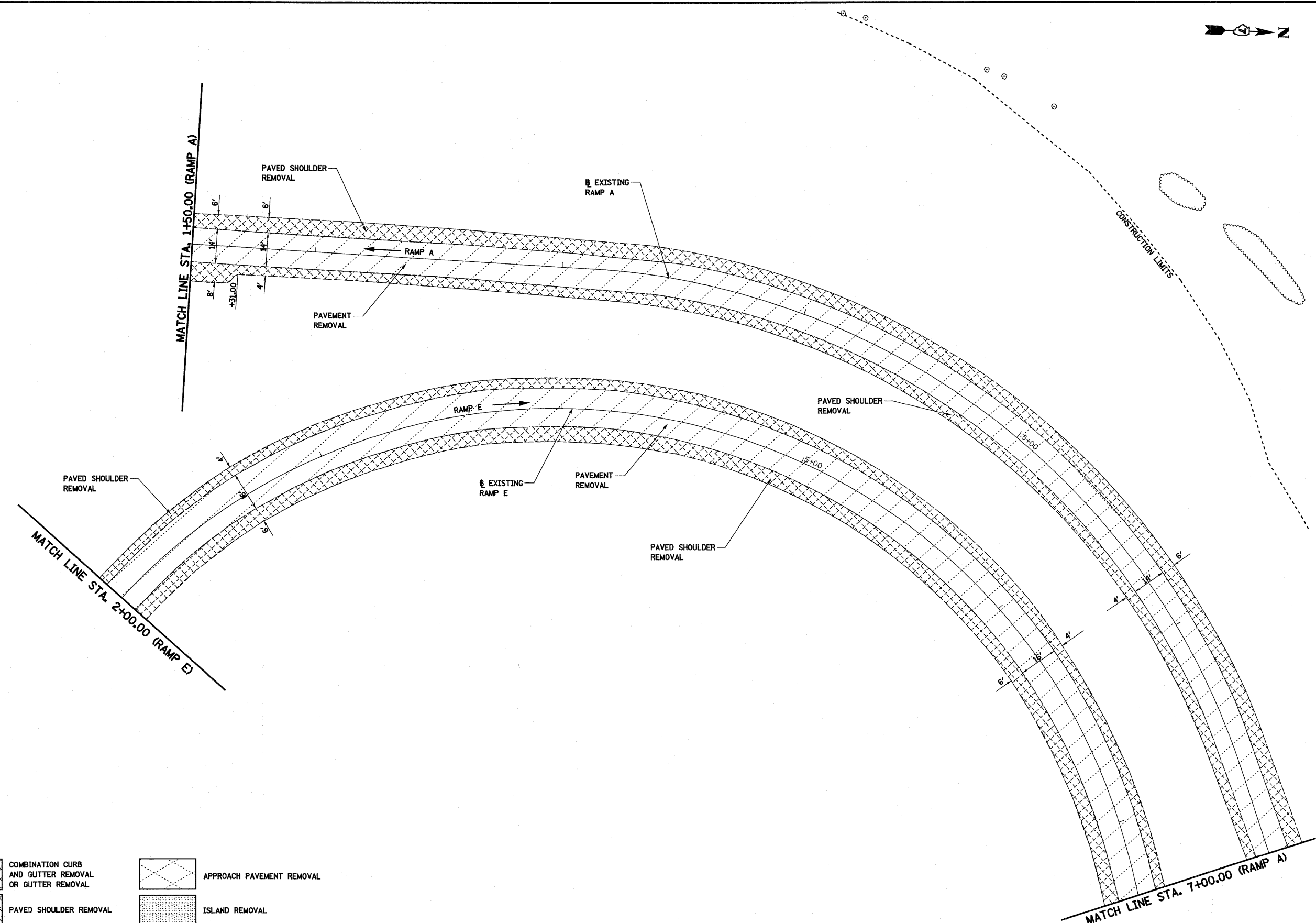

- | | | |
|---|---|---|
|  HOT-MIX ASPHALT SURFACE REMOVAL |  COMBINATION CURB AND GUTTER REMOVAL OR GUTTER REMOVAL |  APPROACH PAVEMENT REMOVAL |
|  PAVEMENT REMOVAL |  PAVED SHOULDER REMOVAL |  ISLAND REMOVAL |
|  DRIVEWAY PAVEMENT REMOVAL |  MEDIAN SURFACE REMOVAL | |
| TREE REMOVAL (UNITS) X | | |



FILE NAME = S:\Projects\403-00072-57-70\sgn\Fayette\removal.pln	USER NAME = paul	DESIGNED - JWS	REVISIONS -	STATE OF ILLINOIS DEPARTMENT OF TRANSPORTATION	REMOVAL PLAN, FAYETTE AVENUE			F.A.I. RTE. 57/70	SECTION (25-3)I-6	COUNTY EFFINGHAM	TOTAL SHEETS 839	SHEET NO. 312
PLOT SCALE = 40.0000' / IN.	PLOT DATE = 6/24/2010	DRAWN - PDB	REVISIONS -		SCALE: 1"=20'	SHEET NO. 8 OF 20 SHEETS	STA. 72+00.00 TO STA. 73+81.75	CONTRACT NO. 74293				
		CHECKED - BRM	REVISIONS -		FED. ROAD DIST. NO. ILLINOIS FED. AID PROJECT							
		DATE - 11-16-07	REVISIONS -									

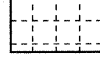

LEGEND

- | | | |
|---|---|---|
|  HOT-MIX ASPHALT SURFACE REMOVAL |  COMBINATION CURB AND GUTTER REMOVAL OR GUTTER REMOVAL |  APPROACH PAVEMENT REMOVAL |
|  PAVEMENT REMOVAL |  PAVED SHOULDER REMOVAL |  ISLAND REMOVAL |
|  DRIVEWAY PAVEMENT REMOVAL |  MEDIAN SURFACE REMOVAL | |
| TREE REMOVAL (UNITS) X | | |

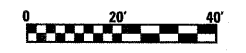

FILE NAME =	USER NAME = paul	DESIGNED - JWS	REVISED -	STATE OF ILLINOIS DEPARTMENT OF TRANSPORTATION	REMOVAL RAMP A AND E, FAYETTE AVENUE	F.A.1 RTE.	SECTION	COUNTY	TOTAL SHEETS	SHEET NO.	
S:\Project\403-00072-57-70\dgn\FayetteRemoval.dgn		DRAWN - PDB	REVISED -			57/70	(25-3)I-6	EFFINGHAM	839	313	
PLOT SCALE = 40.0000' / IN.		CHECKED - BRM	REVISED -			CONTRACT NO. 74293					
PLOT DATE = 6/24/2010		DATE - 11-16-07	REVISED -			SCALE: 1"=20'		SHEET NO. 9 OF 20 SHEETS		STA. 1+50.00 TO STA. 7+00.00	

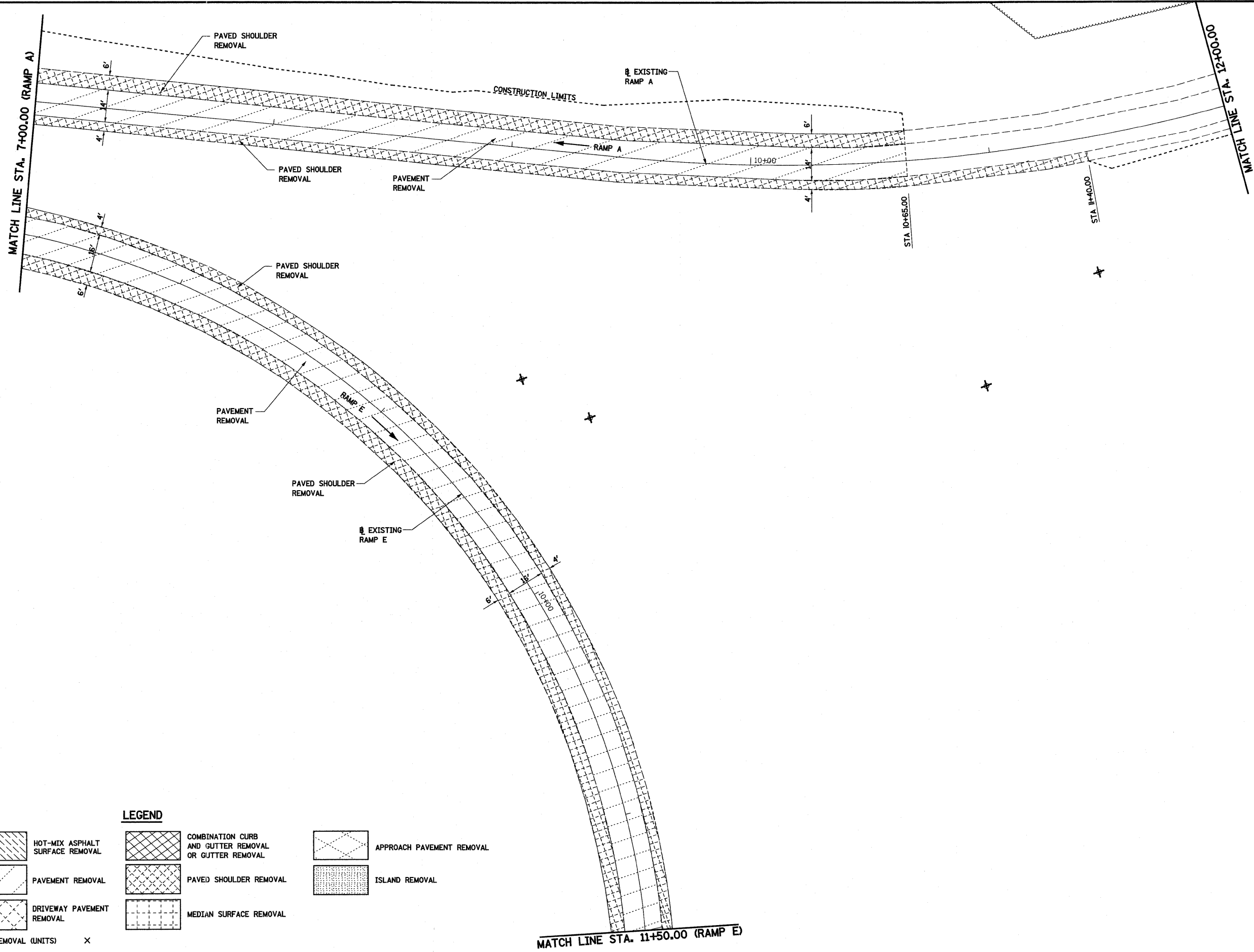

LEGEND

- HOT-MIX ASPHALT SURFACE REMOVAL
- PAVEMENT REMOVAL
- DRIVEWAY PAVEMENT REMOVAL
- TREE REMOVAL (UNITS) X
- COMBINATION CURB AND GUTTER REMOVAL OR GUTTER REMOVAL
- PAVED SHOULDER REMOVAL
- MEDIAN SURFACE REMOVAL
- APPROACH PAVEMENT REMOVAL
- ISLAND REMOVAL

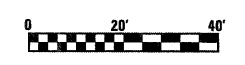

FILE NAME =	USER NAME = paul	DESIGNED - JWS	REVISED -	STATE OF ILLINOIS DEPARTMENT OF TRANSPORTATION	REMOVAL, RAMPS A AND E, FAYETTE AVENUE	F.A. RTE.	SECTION	COUNTY	TOTAL SHEETS	SHEET NO.		
S:\Projects\403-00072-51-10\dgn\Fayette\removal_2018.dgn						57/70	(25-3)I-6	EFFINGHAM	839	314		
PLOT SCALE = 40,0000' / IN.						CONTRACT NO. 74293						
PLOT DATE = 6/24/2018						DATE - 11-16-07	SCALE: 1"=20'	SHEET NO. 10 OF 20 SHEETS	STA. 7+00.00 TO STA. 12+00.00	FED. ROAD DIST. NO. ILLINOIS FED. AID PROJECT		

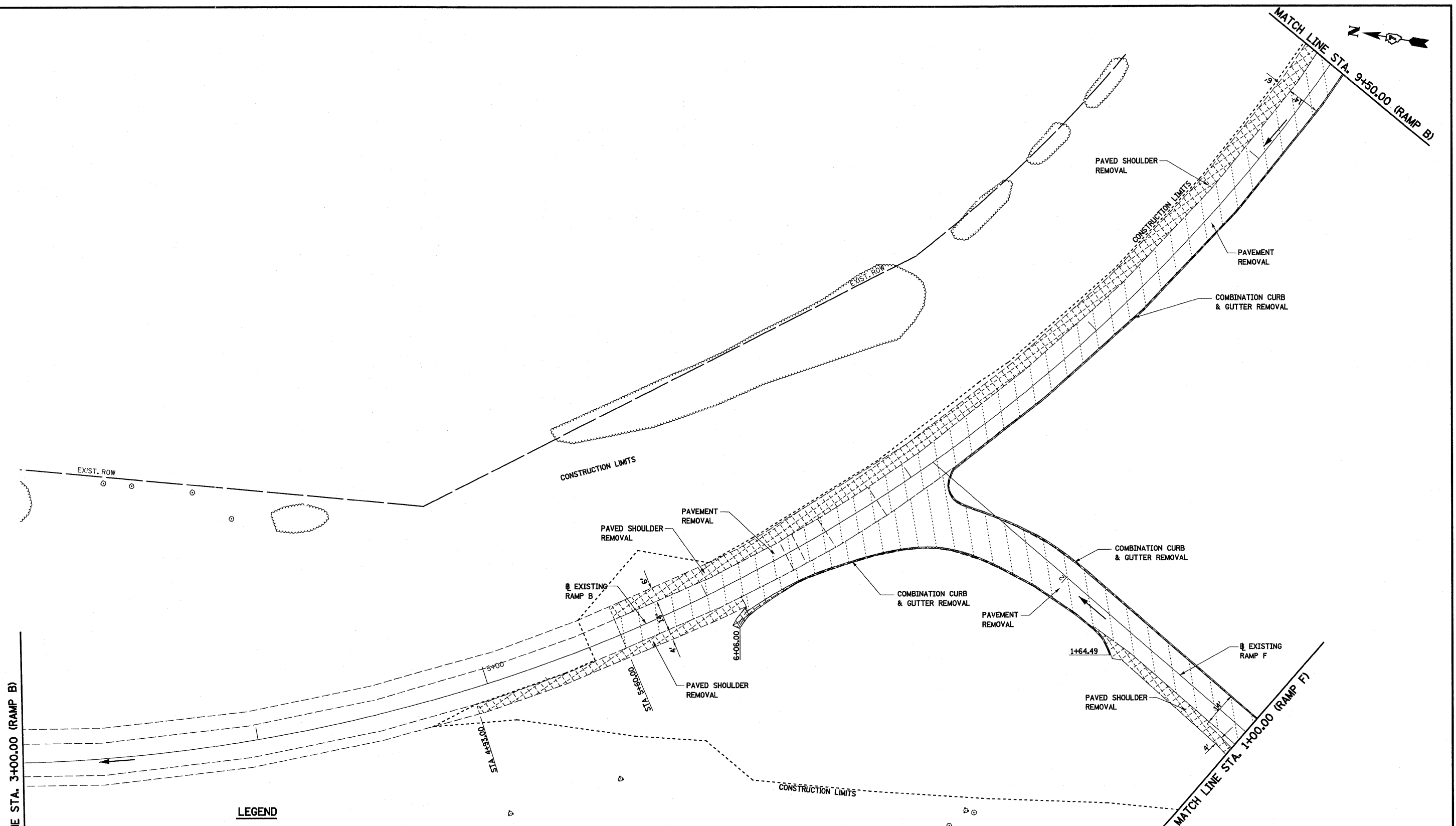

LEGEND

	HOT-MIX ASPHALT SURFACE REMOVAL		COMBINATION CURB AND GUTTER REMOVAL OR GUTTER REMOVAL		APPROACH PAVEMENT REMOVAL
	PAVEMENT REMOVAL		PAVED SHOULDER REMOVAL		ISLAND REMOVAL
	DRIVEWAY PAVEMENT REMOVAL		MEDIAN SURFACE REMOVAL		

TREE REMOVAL (UNITS) X

NOTE: STATIONING OF RAMP F IS REVERSED

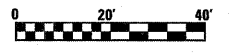

FILE NAME =	USER NAME = paul	DESIGNED - JWS	REVISED -	STATE OF ILLINOIS DEPARTMENT OF TRANSPORTATION	REMOVAL, RAMPS B AND F, FAYETTE AVENUE			F.A. RTE.	SECTION	COUNTY	TOTAL SHEETS	SHEET NO.	
S:\Projects\403-00072-57-70\dgn\FayetteRemoval.dgn		DRAWN - PDB	REVISED -					57/70	(25-3)1-6	EFFINGHAM	839	315	
PLOT SCALE = 40,0000' / IN.		CHECKED - BRM	REVISED -					CONTRACT NO. 74293					
PLOT DATE = 6/24/2010		DATE - 11-06-07	REVISED -					ILLINOIS FED. AID PROJECT					

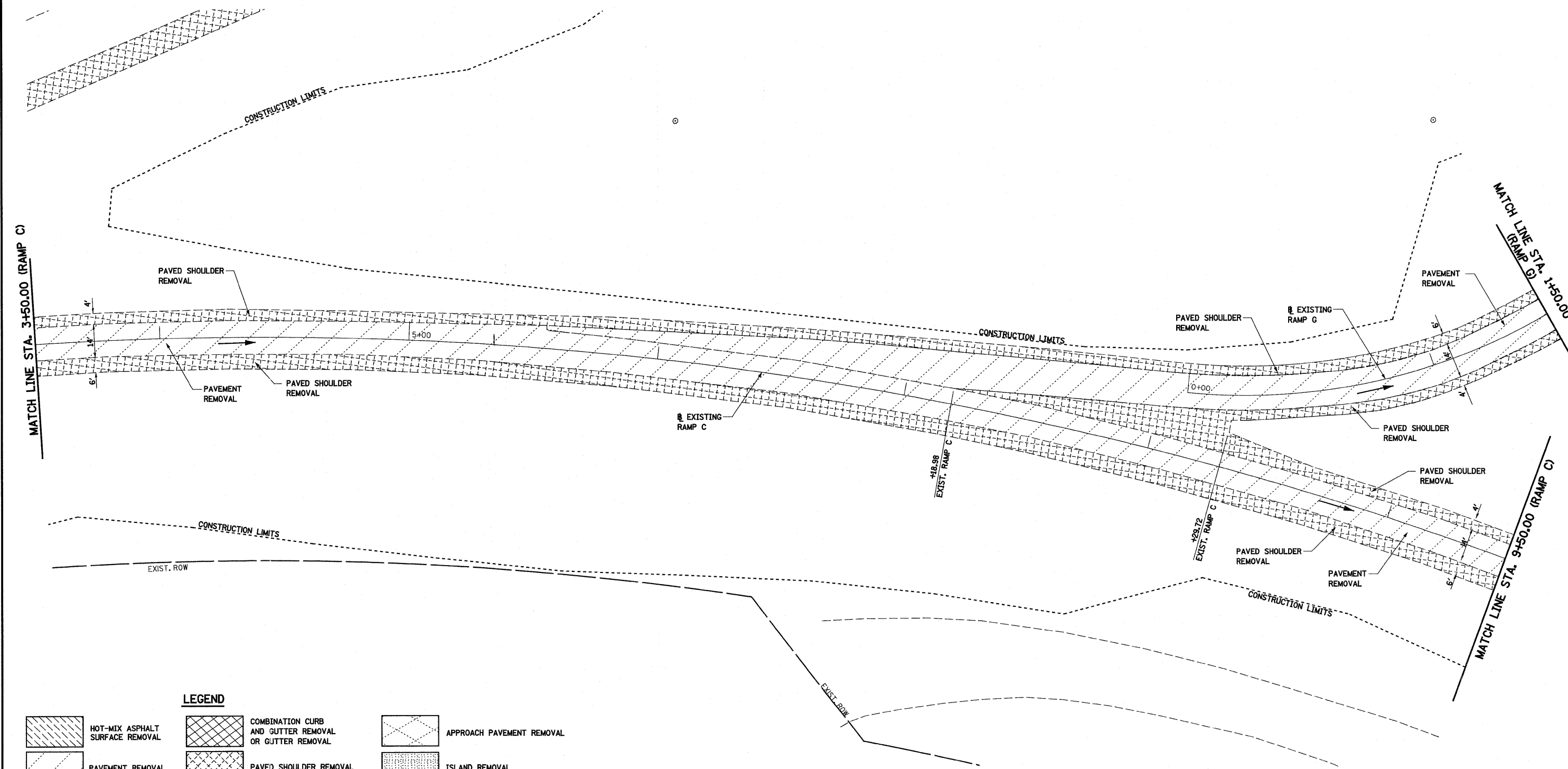
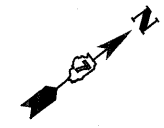

LEGEND



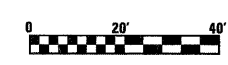

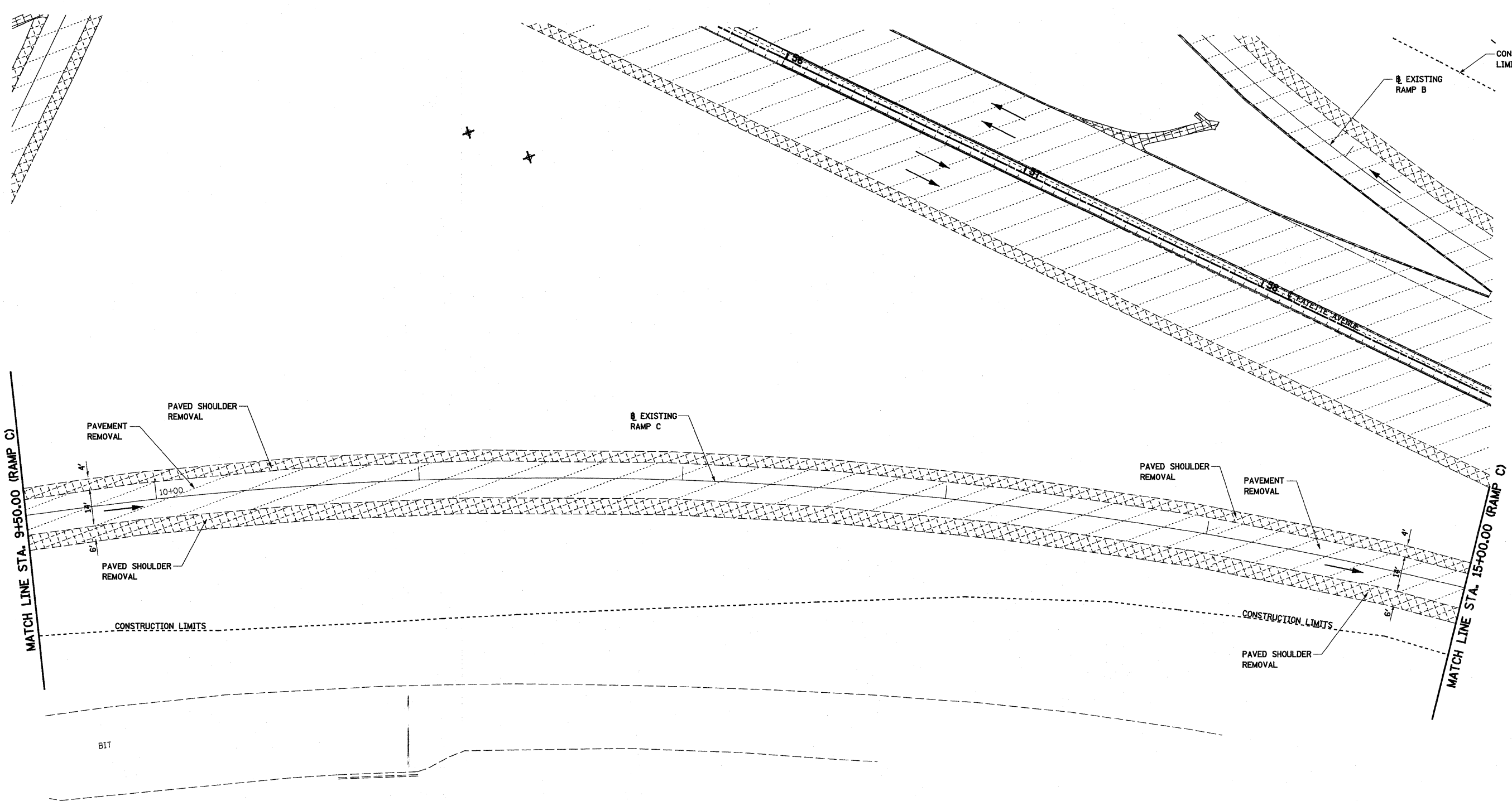

- | | | | | | |
|----------------------|---------------------------------|--|---|--|---------------------------|
| | HOT-MIX ASPHALT SURFACE REMOVAL | | COMBINATION CURB AND GUTTER REMOVAL OR GUTTER REMOVAL | | APPROACH PAVEMENT REMOVAL |
| | PAVEMENT REMOVAL | | PAVED SHOULDER REMOVAL | | ISLAND REMOVAL |
| | DRIVEWAY PAVEMENT REMOVAL | | MEDIAN SURFACE REMOVAL | | |
| TREE REMOVAL (UNITS) | X | | | | |



FILE NAME =	USER NAME = paul	DESIGNED - JWS	REVISED -	STATE OF ILLINOIS DEPARTMENT OF TRANSPORTATION	REMOVAL, RAMPS C AND G, FAYETTE AVENUE	F.A. RTE.	SECTION	COUNTY	TOTAL SHEETS	SHEET NO.
S:\Projects\403-00072-57-70\dgn\Fayette\removal_20.dgn	PLOT SCALE = 40.0000' / IN.	DRAWN - PDB	REVISED -			57/70	(25-3)I-6	EFFINGHAM	839	316
PLOT DATE = 6/24/2010	DATE - 11-16-07	CHECKED - BRM	REVISED -			CONTRACT NO. 74293				
			REVISED -			SCALE: 1"=20'	SHEET NO. 12 OF 20 SHEETS	STA. 3+50.00 TO STA. 9+50.00	FED. ROAD DIST. NO.	ILLINOIS FED. AID PROJECT

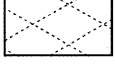

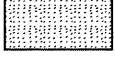
LEGEND

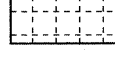
- | | | |
|---|---|---|
|  HOT-MIX ASPHALT SURFACE REMOVAL |  COMBINATION CURB AND GUTTER REMOVAL OR GUTTER REMOVAL |  APPROACH PAVEMENT REMOVAL |
|  PAVEMENT REMOVAL |  PAVED SHOULDER REMOVAL |  ISLAND REMOVAL |
|  DRIVEWAY PAVEMENT REMOVAL |  MEDIAN SURFACE REMOVAL | |
- TREE REMOVAL (UNITS) X

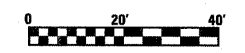

FILE NAME =	USER NAME = paul	DESIGNED - JWS	REVISED -	STATE OF ILLINOIS DEPARTMENT OF TRANSPORTATION	REMOVAL, RAMP C, FAYETTE AVENUE			F.A. RTE.	SECTION	COUNTY	TOTAL SHEETS	SHEET NO.
S:\Projects\483\07-17-07\Drawings\483\483-28-13.dwg		DRAWN - PDB	REVISED -		57/70	(25-3)I-6	EFFINGHAM	839	317			
	PLOT SCALE = 40,0000' / IN.	CHECKED - BRM	REVISED -		CONTRACT NO. 74293							
	PLOT DATE = 6/24/2010	DATE - 11-06-07	REVISED -		SCALE: 1"=20'	SHEET NO. 13 OF 20 SHEETS	STA. 9+50.00 TO STA. 15+00.00	FED. ROAD DIST. NO.	ILLINOIS FED. AID PROJECT			

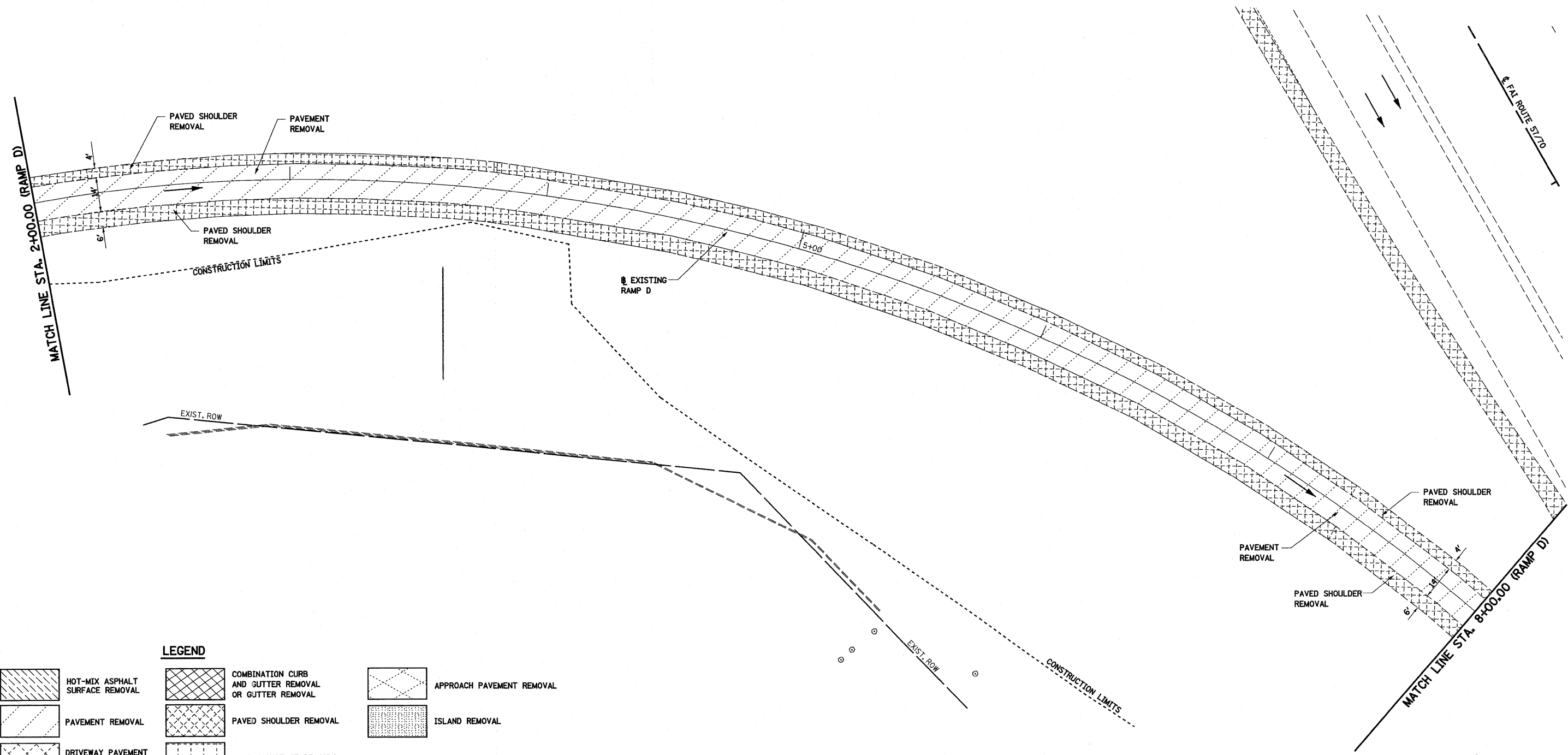
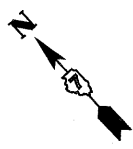



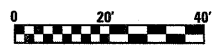

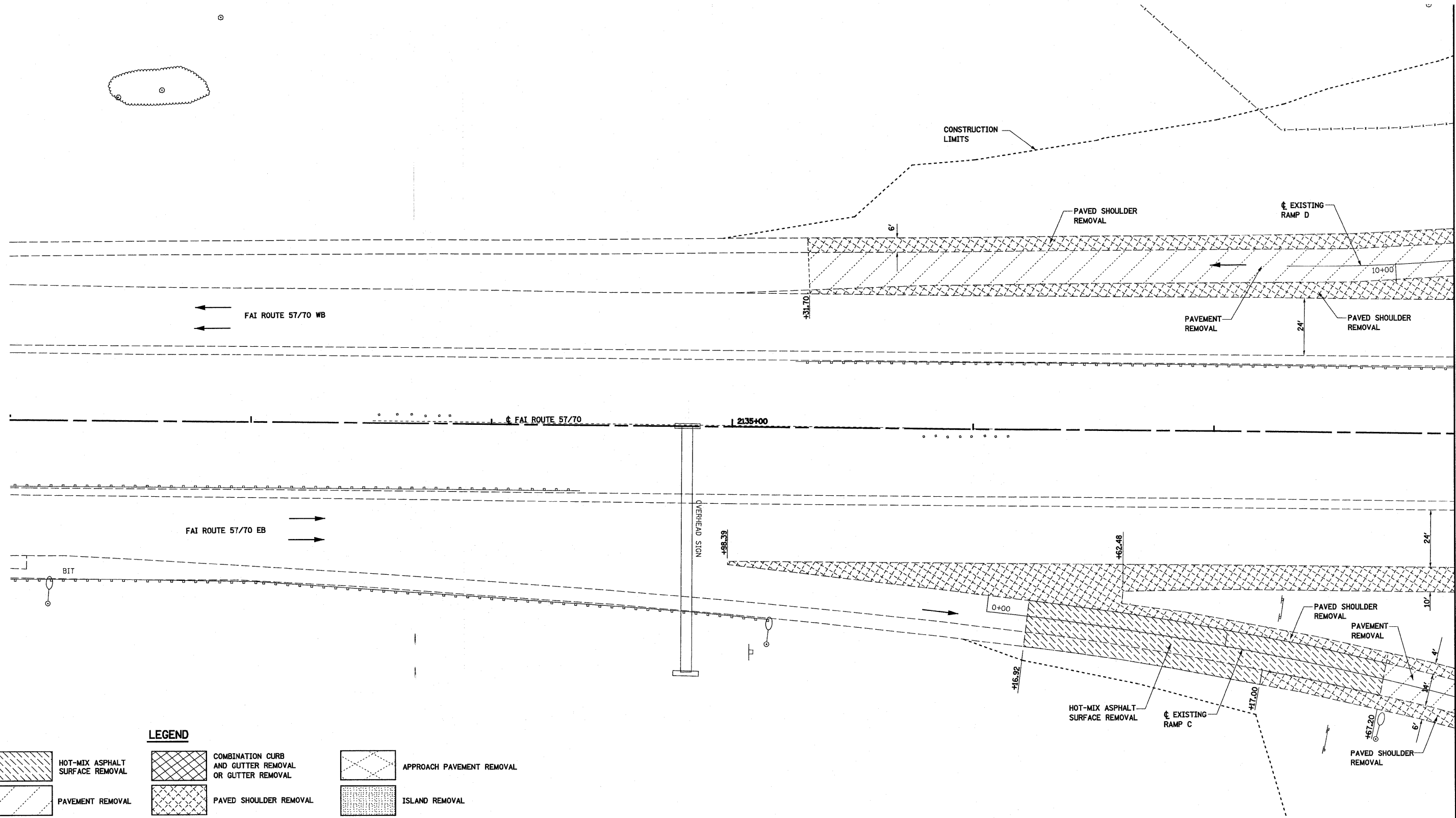

LEGEND			
	HOT-MIX ASPHALT SURFACE REMOVAL		COMBINATION CURB AND GUTTER REMOVAL OR GUTTER REMOVAL
	PAVEMENT REMOVAL		PAVED SHOULDER REMOVAL
	DRIVEWAY PAVEMENT REMOVAL		ISLAND REMOVAL
	TREE REMOVAL (UNITS) X		APPROACH PAVEMENT REMOVAL
			MEDIAN SURFACE REMOVAL



FILE NAME =	USER NAME = paul	DESIGNED - JWS	REVISED -	STATE OF ILLINOIS DEPARTMENT OF TRANSPORTATION	REMOVAL, RAMP D, FAYETTE AVENUE			F.A. RTE.	SECTION	COUNTY	TOTAL SHEETS	SHEET NO.
S:\projects\183-00072-57-70\paul\records\28_Ramp.dgn		DRAWN - PDB	REVISED -		57/70	(25-3)1-6	EFFINGHAM	839	318			
	PLOT SCALE = 40,00000 ' / IN.	CHECKED - BRM	REVISED -		CONTRACT NO. 74293							
	PLOT DATE = 6/24/2010	DATE - 11-16-07	REVISED -		SCALE: 1"=20'	SHEET NO. 14 OF 20 SHEETS	STA. 2+00.00 TO STA. 8+00.00	FED. ROAD DIST. NO.	ILLINOIS FED. AID PROJECT			

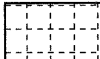

LEGEND

- | | | |
|---|---|---|
|  HOT-MIX ASPHALT SURFACE REMOVAL |  COMBINATION CURB AND GUTTER REMOVAL OR GUTTER REMOVAL |  APPROACH PAVEMENT REMOVAL |
|  PAVEMENT REMOVAL |  PAVED SHOULDER REMOVAL |  ISLAND REMOVAL |
|  DRIVEWAY PAVEMENT REMOVAL |  MEDIAN SURFACE REMOVAL | |
| TREE REMOVAL (UNITS) X | | |

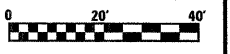

FILE NAME = S:\Projects\403-00072_57-70\dgn\Foyer\removal_20.570.dgn	USER NAME = paul	DESIGNED - JWS	REVISED -	STATE OF ILLINOIS DEPARTMENT OF TRANSPORTATION	REMOVAL, FAI 57/70		F.A.I. RTE. 57/70	SECTION (25-3)1-6	COUNTY EFFINGHAM	TOTAL SHEETS 839	SHEET NO. 319	
PLOT SCALE = 40.0000' / IN.	DRAWN - PDB	CHECKED - BRM	REVISED -		SCALE: 1"=20'	SHEET NO. 15 OF 20 SHEETS	STA. 2135+20.87 TO STA. 2138+00.00	CONTRACT NO. 74293				
PLOT DATE = 6/24/2010	DATE - 11-16-07	REVISED -			FED. ROAD DIST. NO. ILLINOIS FED. AID PROJECT							

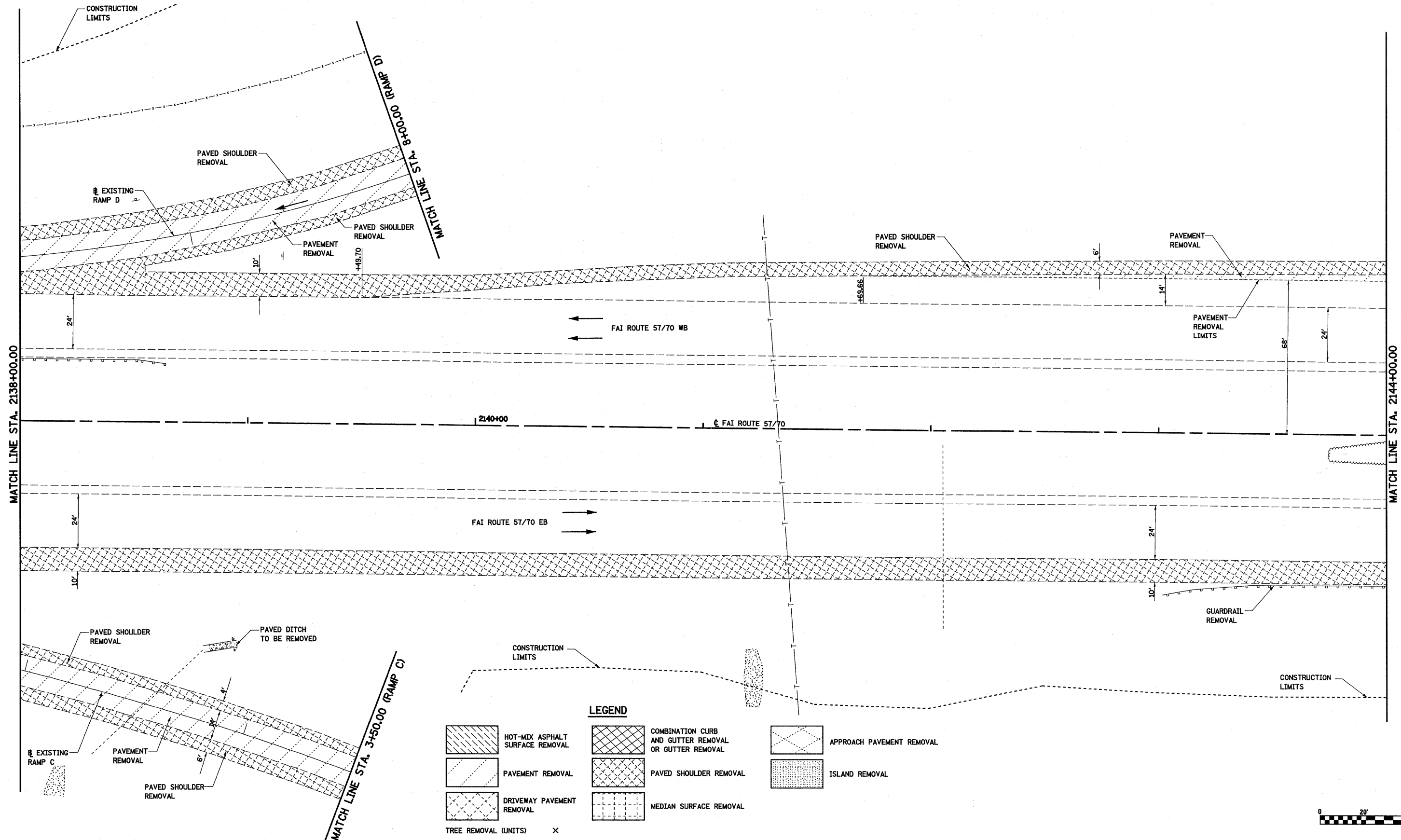

LEGEND

	HOT-MIX ASPHALT SURFACE REMOVAL		COMBINATION CURB AND GUTTER REMOVAL OR GUTTER REMOVAL		APPROACH PAVEMENT REMOVAL
	PAVEMENT REMOVAL		PAVED SHOULDER REMOVAL		ISLAND REMOVAL
	DRIVEWAY PAVEMENT REMOVAL		MEDIAN SURFACE REMOVAL		

TREE REMOVAL (UNITS) X

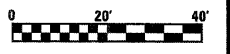

FILE NAME =	USER NAME = paul	DESIGNED - JWS	REVISED -	STATE OF ILLINOIS DEPARTMENT OF TRANSPORTATION	REMOVAL, FAI 57/70		F.A.I. RTE. 57/70	SECTION (25-3)1-6	COUNTY EFFINGHAM	TOTAL SHEETS 839	SHEET NO. 320	
SA\Projects\403-00072.57-70\dgn\Fayette\removal.20.570.dgn	PLOT SCALE = 40,0000' / IN.	DRAWN - PDB	REVISED -		SCALE: 1"=20'	SHEET NO. 16 OF 20 SHEETS	STA. 2138+00.00 TO STA. 2144+00.00	CONTRACT NO. 74293				
	PLOT DATE = 6/24/2010	CHECKED - BRM	REVISED -		FED. ROAD DIST. NO. (ILLINOIS) FED. AID PROJECT							
		DATE - 11-16-07	REVISED -									

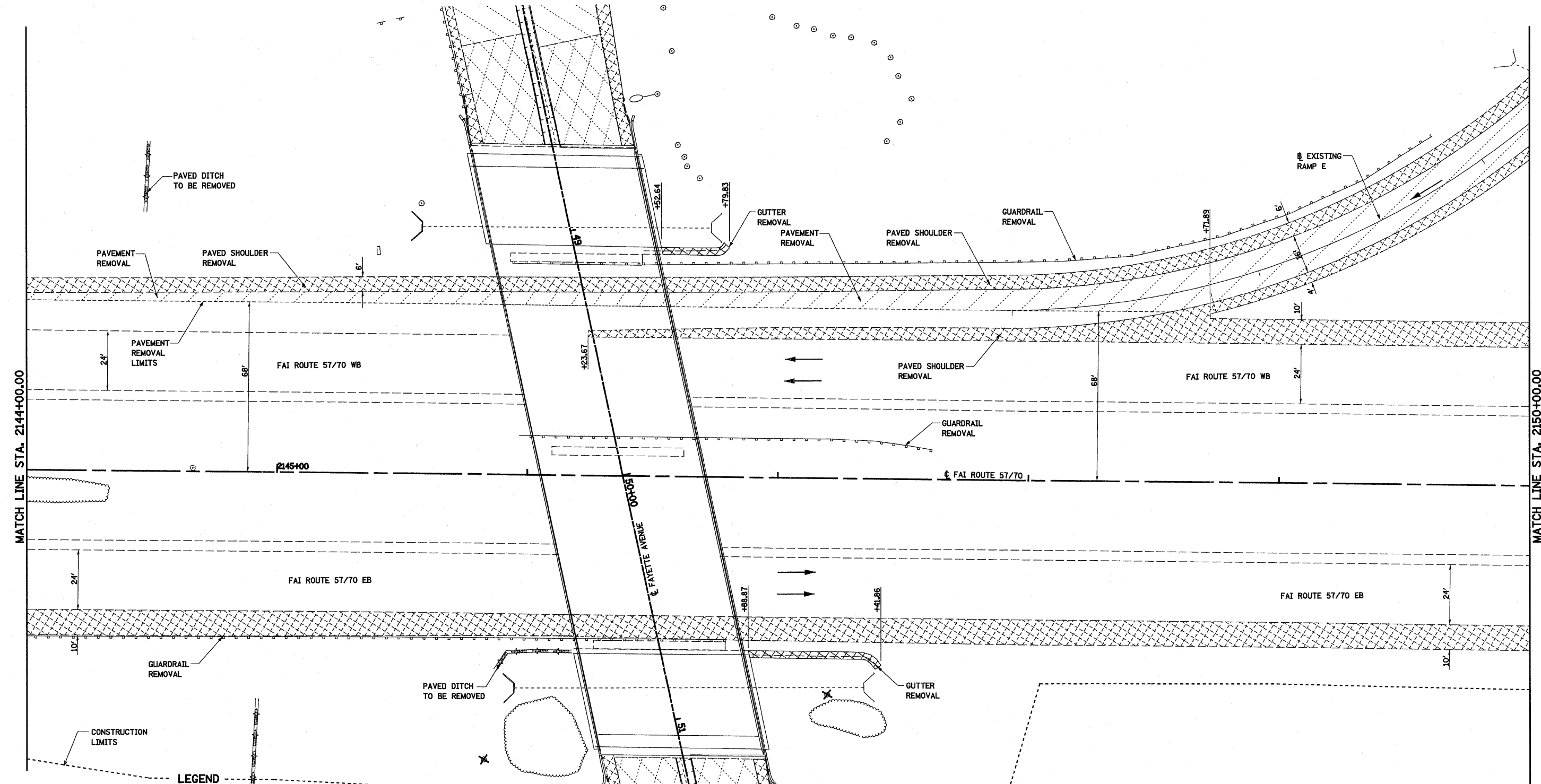

LEGEND

	HOT-MIX ASPHALT SURFACE REMOVAL		COMBINATION CURB AND GUTTER REMOVAL OR GUTTER REMOVAL		APPROACH PAVEMENT REMOVAL
	PAVEMENT REMOVAL		PAVED SHOULDER REMOVAL		ISLAND REMOVAL
	DRIVEWAY PAVEMENT REMOVAL		MEDIAN SURFACE REMOVAL		

TREE REMOVAL (UNITS) X

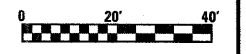

FILE NAME = S:\Projects\403-00072-57-70\dgn\Fayette\removal_20.970.dgn	USER NAME = paul	DESIGNED - JWS	REVISED -	STATE OF ILLINOIS DEPARTMENT OF TRANSPORTATION	REMOVAL, FAI 57/70			F.A.I. RTE. 57/70	SECTION (25-3)I-6	COUNTY EFFINGHAM	TOTAL SHEETS 839	SHEET NO. 321
	PLOT SCALE = 40.00000' / IN.	DRAWN - PDB	REVISED -		SCALE: 1"=20'	SHEET NO. 17 OF 20 SHEETS	STA. 2144+00.00 TO STA. 2150+00.00	CONTRACT NO. 74293				
	PLOT DATE = 6/24/2018	CHECKED - BRM	REVISED -		FED. ROAD DIST. NO. ILLINOIS FED. AID PROJECT							
		DATE - 11-16-07	REVISED -									



MATCH LINE STA. 11+50.00
(RAMP E)
EXISTING RAMP E

MATCH LINE STA. 12+00.00
(RAMP A)

PAVED DITCH TO BE REMOVED

PAVED SHOULDER REMOVAL

MATCH LINE STA. 2150+00.00

MATCH LINE STA. 2156+00.00

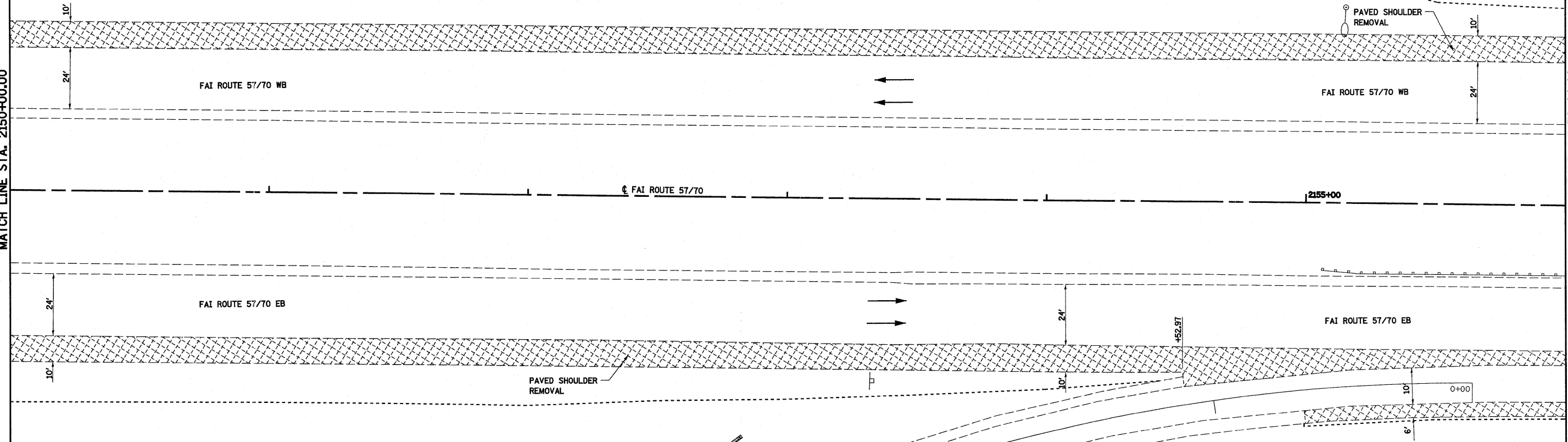

LEGEND

- HOT-MIX ASPHALT SURFACE REMOVAL
 - COMBINATION CURB AND GUTTER REMOVAL OR GUTTER REMOVAL
 - APPROACH PAVEMENT REMOVAL
 - PAVED SHOULDER REMOVAL
 - ISLAND REMOVAL
 - PAVEMENT REMOVAL
 - PAVED SHOULDER REMOVAL
 - DRIVEWAY PAVEMENT REMOVAL
 - MEDIAN SURFACE REMOVAL
- TREE REMOVAL (UNITS) X



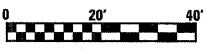



MATCH LINE STA. 3+00.00
(RAMP B)

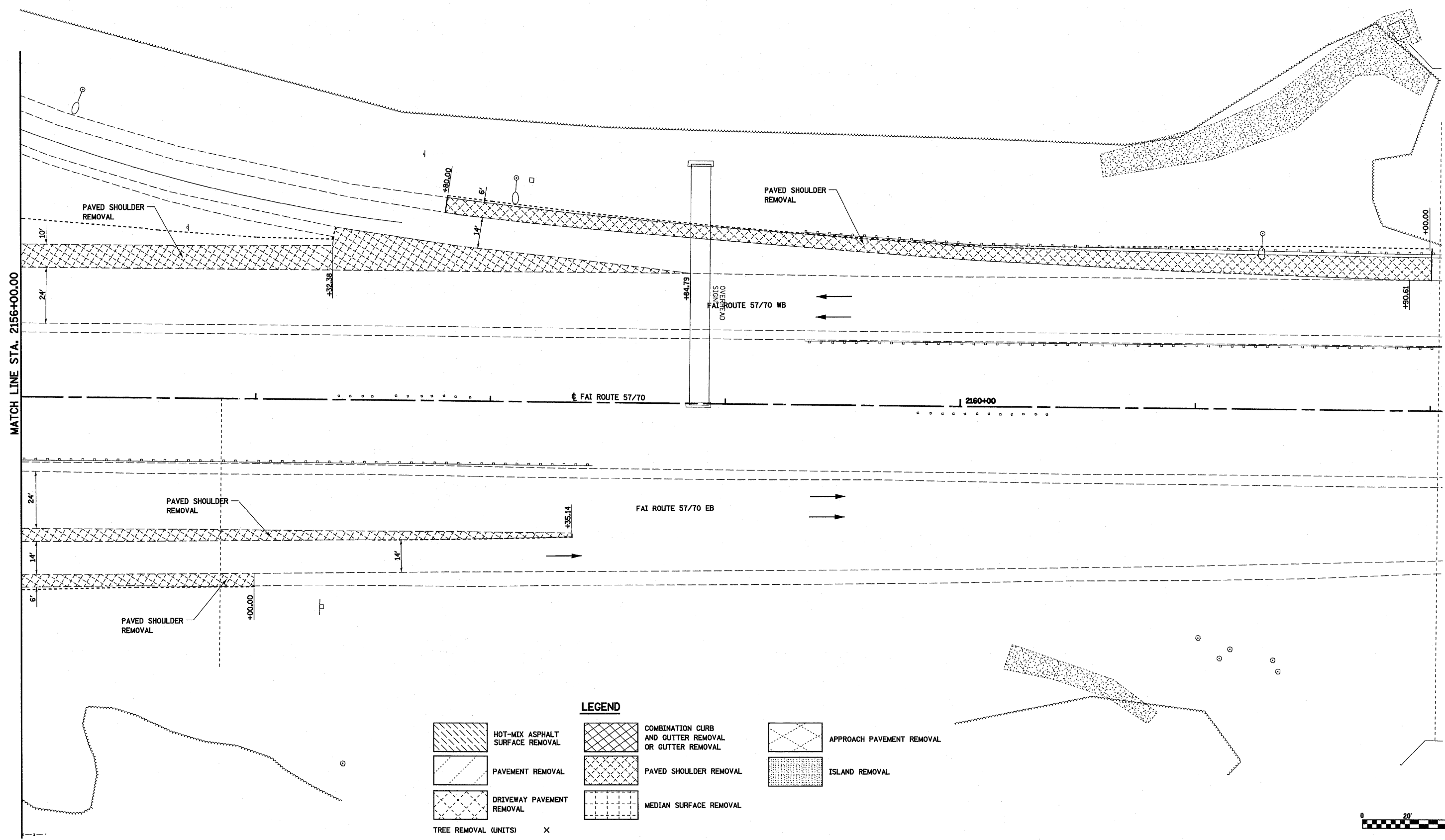

FILE NAME =	USER NAME = paul	DESIGNED - JWS	REVISED -	STATE OF ILLINOIS DEPARTMENT OF TRANSPORTATION	REMOVAL, FAI 57/70	F.A.I. RTE.	SECTION	COUNTY	TOTAL SHEETS	SHEET NO.	
S:\Projects\403-00072-57-70\dgn\Fayette\resoval_20.070.dgn	PLOT SCALE = 40,0000' / IN.	DRAWN - PDB	REVISED -			57/70	(25-3)I-6	EFFINGHAM	839	322	
PLOT DATE = 6/24/2018	DATE - 11-16-07	CHECKED - BRM	REVISED -			CONTRACT NO. 74293					
			REVISED -			ILLINOIS FED. AID PROJECT					

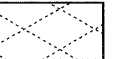
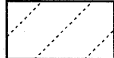
SCALE: 1"=20' SHEET NO. 18 OF 20 SHEETS STA. 2150+00.00 TO STA. 2156+00.00

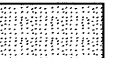

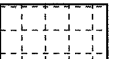
- | | | | | | |
|---|---------------------------------|---|---|---|---------------------------|
|  | HOT-MIX ASPHALT SURFACE REMOVAL |  | COMBINATION CURB AND GUTTER REMOVAL OR GUTTER REMOVAL |  | APPROACH PAVEMENT REMOVAL |
|  | PAVEMENT REMOVAL |  | PAVED SHOULDER REMOVAL |  | ISLAND REMOVAL |
|  | DRIVEWAY PAVEMENT REMOVAL |  | MEDIAN SURFACE REMOVAL | | |
| | TREE REMOVAL (UNITS) X | | | | |

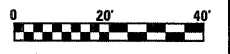

FILE NAME =	USER NAME = paul	DESIGNED - JWS	REVISED -	STATE OF ILLINOIS DEPARTMENT OF TRANSPORTATION	REMOVAL, FAI 57/70	F.A.I. RTE.	SECTION	COUNTY	TOTAL SHEETS	SHEET NO.	
S:\Projects\403-00072-57-70\dm\paul\faistte\removal.20.570.dgn		DRAWN - PDB	REVISED -			57/70	(25-3)I-6	EFFINGHAM	839	323	
PLOT SCALE = 40.0000' / IN.		CHECKED - BRM	REVISED -			SCALE: 1"=20'		SHEET NO. 19 OF 20 SHEETS		STA. 2156+00.00 TO STA. 2162+00.00	
PLOT DATE = 6/24/2010		DATE - 11-16-07	REVISED -			FED. ROAD DIST. NO. ILLINOIS FED. AID PROJECT					
						CONTRACT NO. 74293					

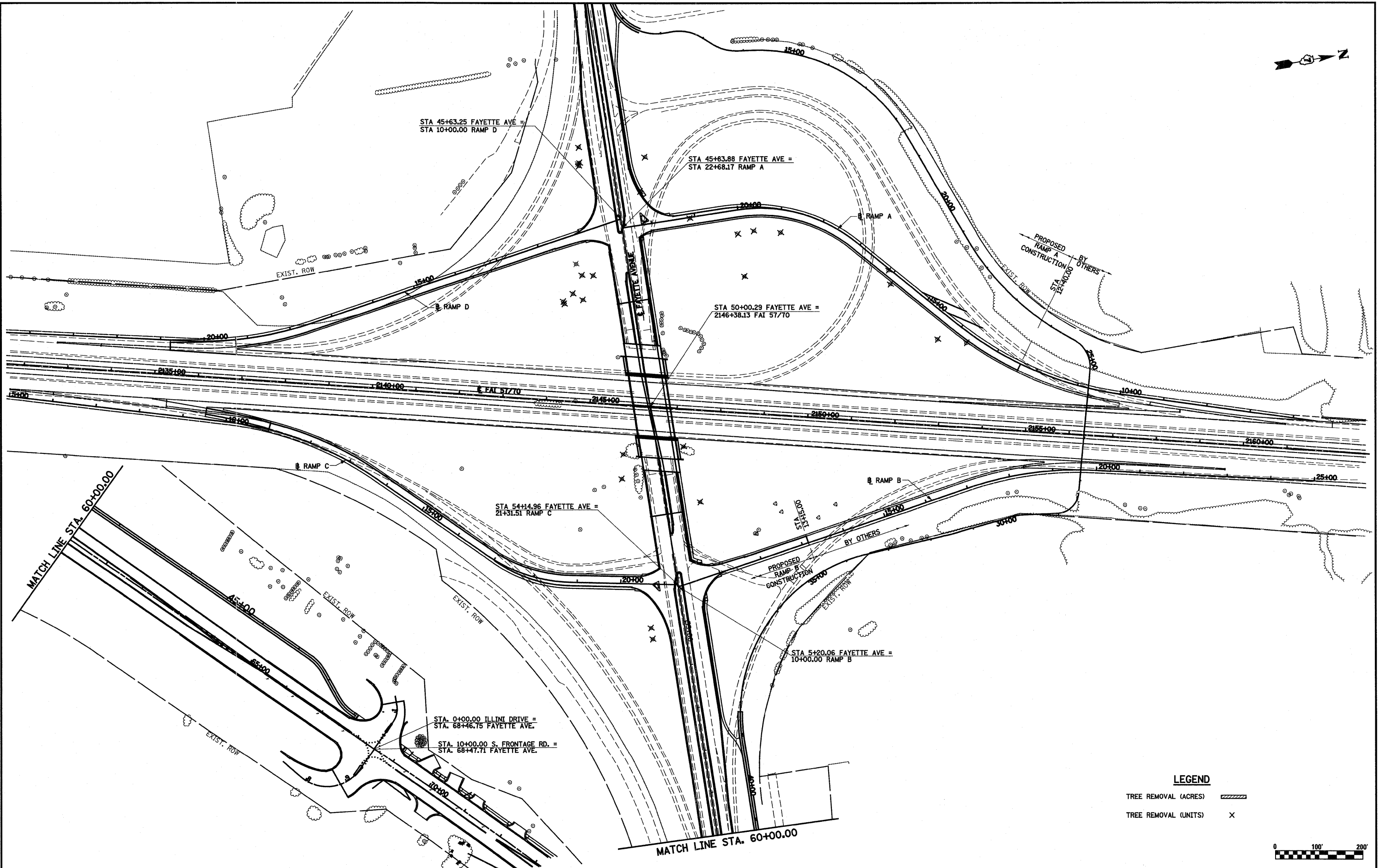

- TREE REMOVAL (ACRES)
- TREE REMOVAL (UNITS)

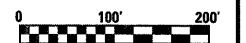

FILE NAME =	USER NAME = paul	DESIGNED - JWS	REVISED -
S:\Projects\403-00072.51-70\dgn\Fayette\tree removal.dgn		DRAWN - PDB	REVISED -
	PLOT SCALE = 200.0000' / IN.	CHECKED - BRM	REVISED -
	PLOT DATE = 6/24/2010	DATE - 11-16-08	REVISED -

**STATE OF ILLINOIS
DEPARTMENT OF TRANSPORTATION**

TREE REMOVAL	
SCALE: 1"=100'	SHEET NO. 20 OF 20 SHEETS
STA. 32+71.37 TO STA. 73+81.75	

F.A.I. RTE.	SECTION	COUNTY	TOTAL SHEETS	SHEET NO.
57/70	(25-3)I-6	EFFINGHAM	839	324
CONTRACT NO. 74293				
FED. ROAD DIST. NO. ILLINOIS FED. AID PROJECT				

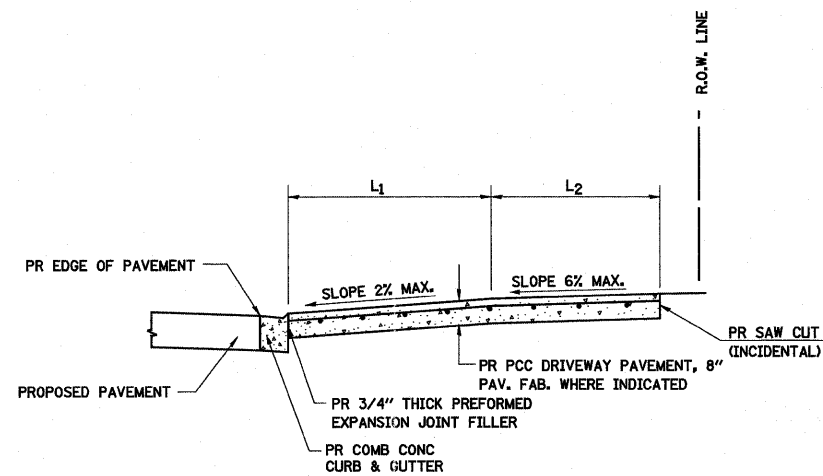

**SECTION A-A
FOR EX PC CONC CE**

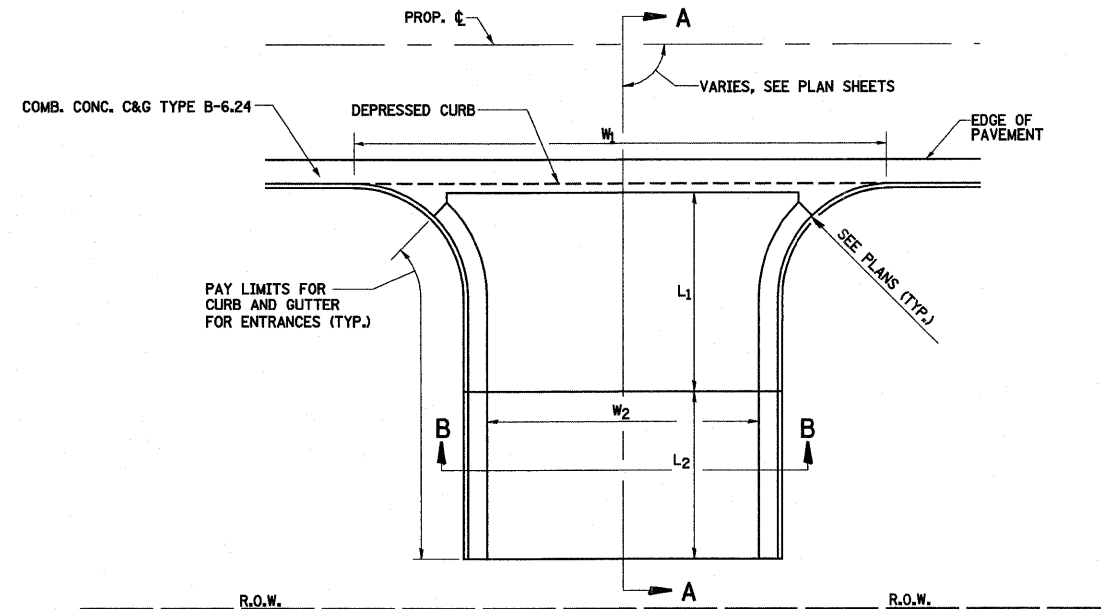

**PLAN - URBAN PE & CE
RADIUS RETURNS**

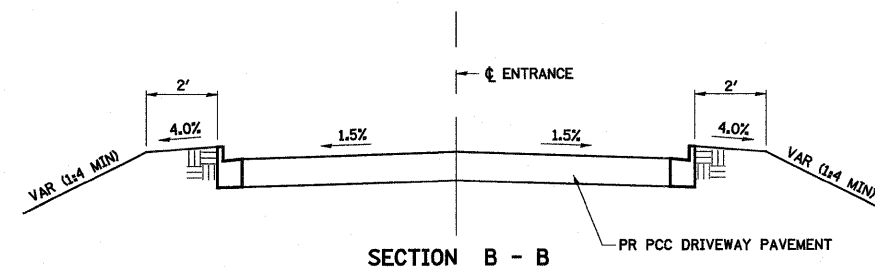

SECTION B - B

ENTRANCE SCHEDULE

LOCATION	TYPE	L1	L2	W1	W2	PORTLAND CEMENT CONCRETE DRIVEWAY PAVEMENT, 8 INCH (SQ YD)	AGGREGATE FOR TEMPORARY ACCESS (TON)	PAVEMENT FABRIC (SQ YD)	PROTECTIVE COAT (SQ YD)
37+00.44	F. R.	10.1'	8.7'	66.1'	42.7'	103	46	103	103
70+23.20	CE	10.0'	28.0'	91.0'	30.9'	161		161	161
SUBTOTAL						264	46	264	264
TOTAL						264*	46*	264*	264*

*NOT A TOTAL QUANTITY

GENERAL NOTES:

1. THE COMBINATION CONCRETE GUTTER SHALL HAVE A DEPRESSED CURB THROUGH THE ENTRANCE.
2. THE COST OF FURNISHING AND INSTALLING THE 3/4" PREFORMED EXPANSION JOINT FILLER AND REINFORCEMENT BARS SHALL BE INCLUDED IN THE COST OF P.C.C. DRIVEWAY PAVEMENT.
3. THE REMOVAL AND DISPOSAL OF THE DRIVEWAY PAVEMENT STRUCTURE, INCLUDING SURFACE, BASE, AND SUB-BASE, SHALL BE INCLUDED IN THE CONTRACT UNIT PRICE FOR "DRIVEWAY PAVEMENT REMOVAL."

FILE NAME =	USER NAME = paul	DESIGNED - JWS	REVISED -	STATE OF ILLINOIS DEPARTMENT OF TRANSPORTATION	ENTRANCE DETAILS, FAYETTE AVE.			F.A.I. RTE.	SECTION	COUNTY	TOTAL SHEETS	SHEET NO.	
S:\Projects\403-00072-57-70\ dgn\Fayette\entrance.dwg		DRAWN - PDB	REVISED -		SCALE: 1"=20'	SHEET NO. 1 OF 2 SHEETS	STA.	TO STA.	57/70	(25-3) I-6	EFFINGHAM	839	325
PLOT SCALE = 40,0000' / IN.		CHECKED - BRM	REVISED -		CONTRACT NO. 74293								
PLOT DATE = 6/24/2010		DATE - 11-05-07	REVISED -		FED. ROAD DIST. NO. ILLINOIS FED. AID PROJECT								

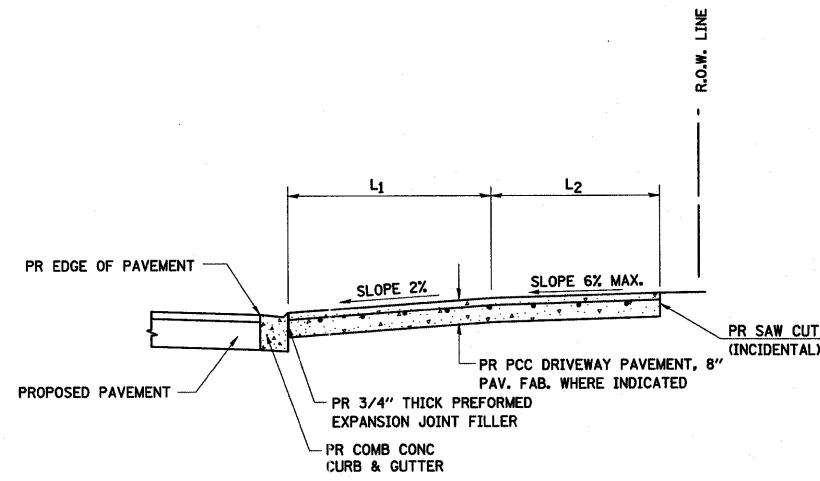

**SECTION A-A
FOR EX PC CONC CE**

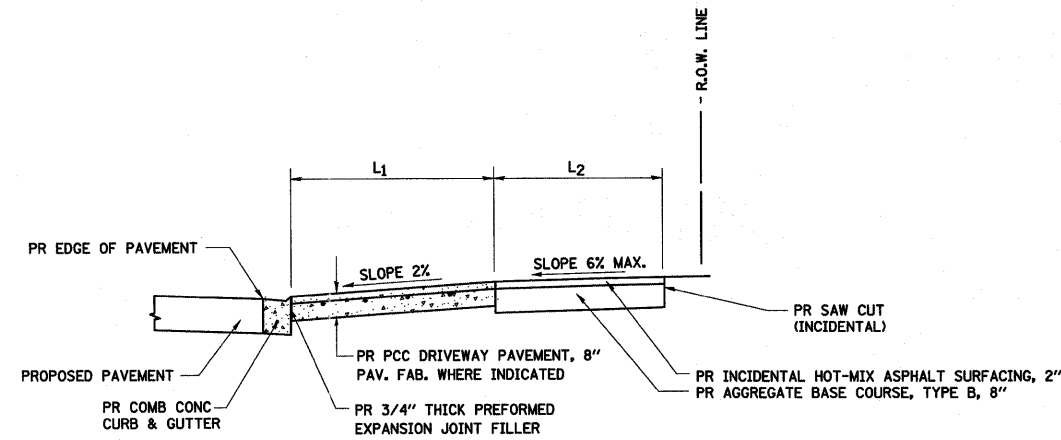

**SECTION A-A
FOR EX ASPHALT CE**

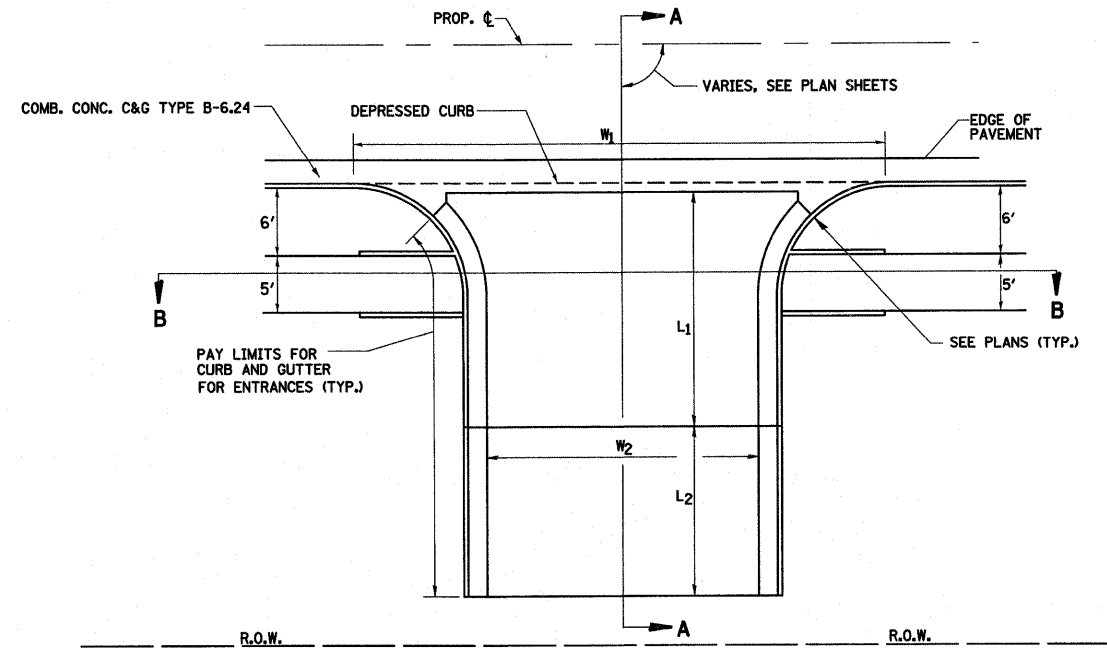

**PLAN - URBAN PE & CE
RADIUS RETURNS**

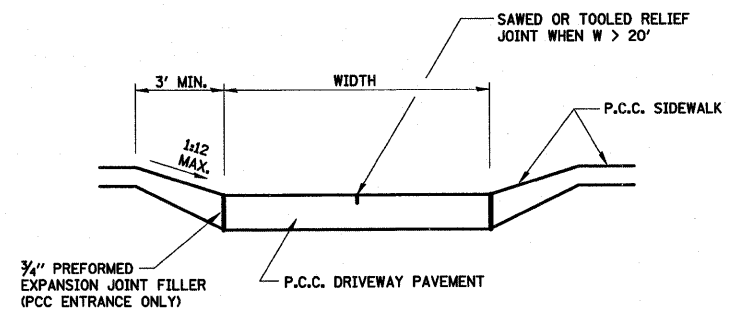

SECTION B-B

ENTRANCE SCHEDULE

LOCATION	TYPE	L1	L2	W1	W2	PORTLAND CEMENT CONCRETE DRIVEWAY PAVEMENT, 8 INCH (SQ YD)	BITUMINOUS MATERIALS (PRIME COAT) (GALLON)	INCIDENTAL HOT-MIX ASPHALT SURFACING (TON)	AGGREGATE BASE COURSE, TYPE B, 8" (SQ YD)	PAVEMENT FABRIC (SQ YD)	AGGREGATE FOR TEMPORARY ACCESS (TON)	PROTECTIVE COAT (SQ YD)
STATION												
69+64.35	CE	13.4'	21.7'	63.8'	30.5'	125				125		125
70+44.51	CE	11.7'	18.7'	56.0'	30.7'	107				107		107
71+11.10	CE	11'	6.5'	60.5'	25.6'	58				58	26	58
72+23.42	CE	11'	6.7'	72.6'	32.6'	51	9.3	3	25	51		51
SUBTOTAL						341	9	3	25	341	26	341
TOTAL						341*	9*	3*	25*	341*	26*	341*

*NOT A TOTAL QUANTITY

GENERAL NOTES:

1. THE COMBINATION CONCRETE GUTTER SHALL HAVE A DEPRESSED CURB THROUGH THE ENTRANCE.
2. THE COST OF FURNISHING AND INSTALLING THE 3/4" PREFORMED EXPANSION JOINT FILLER AND REINFORCEMENT BARS SHALL BE INCLUDED IN THE COST OF P.C.C. DRIVEWAY PAVEMENT.
3. THE REMOVAL AND DISPOSAL OF THE DRIVEWAY PAVEMENT STRUCTURE, INCLUDING SURFACE, BASE, AND SUB-BASE, SHALL BE INCLUDED IN THE CONTRACT UNIT PRICE FOR "DRIVEWAY PAVEMENT REMOVAL."

**PROP. FAYETTE RAMP A
CURVE C53**
 PI STA. = 12+14.41
 $\Delta = 31^\circ 30' 34''$ (RT)
 $D = 7^\circ 32' 20''$
 $R = 760.00'$
 $T = 214.41'$
 $L = 417.96'$
 $E = 29.67'$
 $e = 8.00\%$
 $T.R. = 48'$
 $S.E. RUN = 255'$
 $P.C. STA. = 10+00.00$
 $P.T. STA. = 14+17.96$

**PROP. FAYETTE RAMP A
CURVE C54**
 PI STA. = 18+64.45
 $\Delta = 48^\circ 09' 41''$ (LT)
 $D = 16^\circ 22' 13''$
 $R = 350.00'$
 $T = 156.42'$
 $L = 294.20'$
 $E = 33.36'$
 $e = 7.90\%$
 $T.R. = 39'$
 $S.E. RUN = 205'$
 $P.C. STA. = 17+08.03$
 $P.T. STA. = 20+02.23$

**PROP. FAYETTE RAMP B
CURVE C51**
 PI STA. = 18+49.11
 $\Delta = 21^\circ 34' 00''$ (RT)
 $D = 7^\circ 32' 20''$
 $R = 760.00'$
 $T = 144.75'$
 $L = 286.07'$
 $E = 13.66'$
 $e = 8.00\%$
 $T.R. = 48'$
 $S.E. RUN = 255'$
 $P.C. STA. = 17+04.36$
 $P.T. STA. = 19+90.43$

**PROP. FAYETTE RAMP C
CURVE C51**
 PI STA. = 11+88.04
 $\Delta = 27^\circ 47' 40''$ (RT)
 $D = 7^\circ 32' 20''$
 $R = 760.00'$
 $T = 188.04'$
 $L = 368.68'$
 $E = 22.92'$
 $e = 8.00\%$
 $T.R. = 48'$
 $S.E. RUN = 255'$
 $P.C. STA. = 10+00.00$
 $P.T. STA. = 13+68.68$

**PROP. FAYETTE RAMP C
CURVE C52**
 PI STA. = 17+86.90
 $\Delta = 33^\circ 27' 19''$ (LT)
 $D = 16^\circ 22' 13''$
 $R = 350.00'$
 $T = 105.19'$
 $L = 204.37'$
 $E = 15.47'$
 $e = 7.90\%$
 $T.R. = 39'$
 $S.E. RUN = 205'$
 $P.C. STA. = 16+81.71$
 $P.T. STA. = 18+86.08$

**PROP. FAYETTE RAMP D
CURVE C50**
 PI STA. = 18+94.07
 $\Delta = 21^\circ 27' 44''$ (RT)
 $D = 7^\circ 32' 20''$
 $R = 760.00'$
 $T = 144.03'$
 $L = 284.69'$
 $E = 13.53'$
 $e = 8.00\%$
 $T.R. = 48'$
 $S.E. RUN = 255'$
 $P.C. STA. = 17+50.04$
 $P.T. STA. = 20+34.73$

**PROP. RAMP C TERMINAL TIE-IN
CURVE TFAYRC-1**
 PI STA. = 10+25.30
 $\Delta = 5^\circ 59' 03''$ (RT)
 $D = 4^\circ 00' 07''$
 $R = 1,431.68'$
 $T = 74.83'$
 $L = 149.53'$
 $E = 1.95'$
 $e = 1.95\%$
 $P.C. STA. = 9+50.47$
 $P.T. STA. = 11+00.00$

**PROP. RAMP D TERMINAL TIE-IN
CURVE TFAYRD-1**
 PI STA. = 20+02.71
 $\Delta = 6^\circ 21' 58''$ (RT)
 $D = 4^\circ 14' 39''$
 $R = 1,350.00'$
 $T = 75.08'$
 $L = 150.00'$
 $E = 2.09'$
 $e = 2.09\%$
 $P.C. STA. = 19+27.63$
 $P.T. STA. = 20+77.63$

RADIUS OF CURVE FEET	SPACING ON CURVE FEET
LESS THAN 100	20
100 - 174	30
175 - 224	35
225 - 274	40
275 - 349	50
350 - 449	55
450 - 549	65
550 - 649	70
650 - 749	75
750 - 849	80
850 - 949	85
950 - 1049	90
1050 - 1299	100
1300 - 1999	125
2000 - 2999	150
3000 - 3999	175
4000 OR GREATER	400

TABLE A

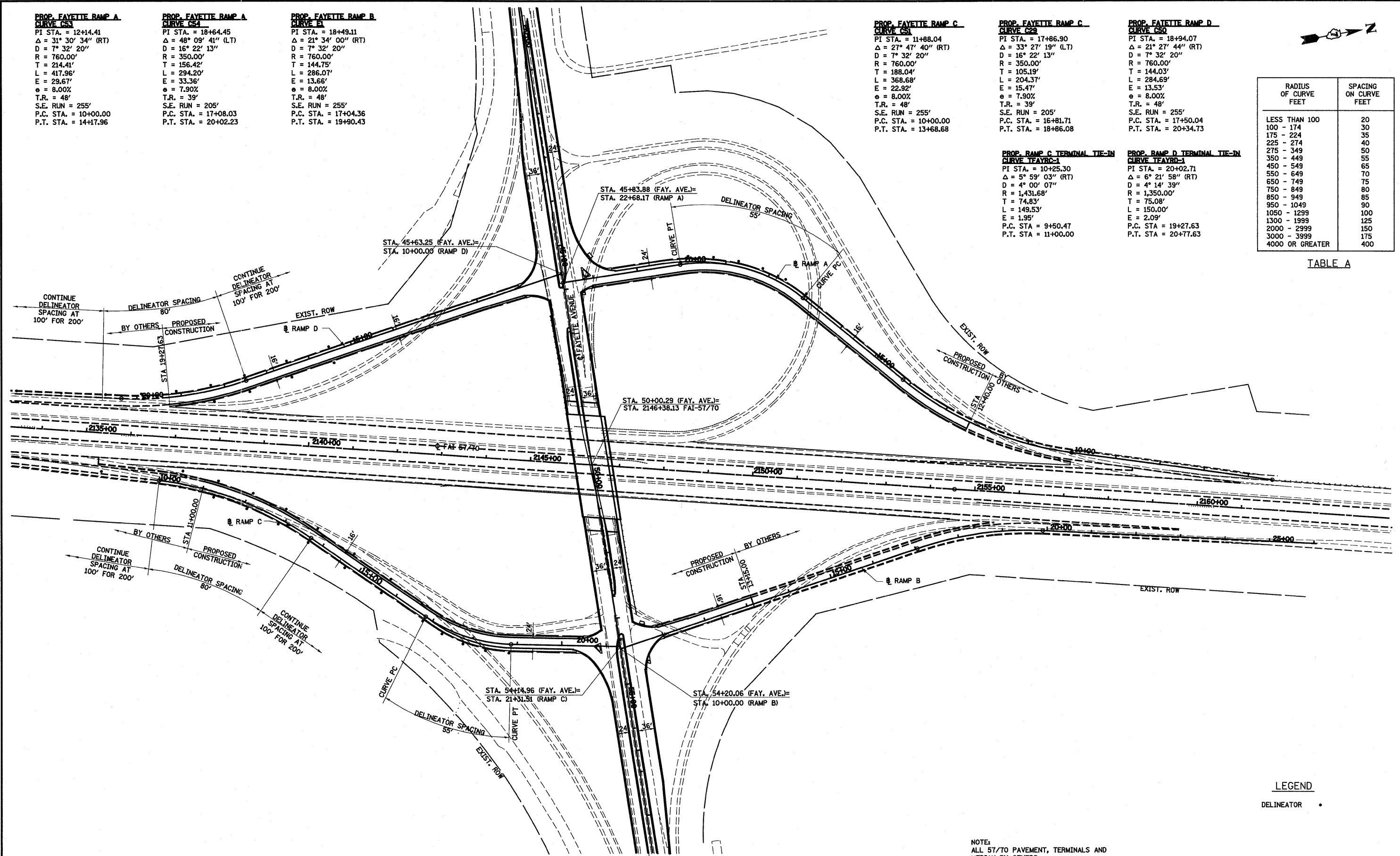

LEGEND

DELINATOR

NOTE:
 ALL 57/70 PAVEMENT, TERMINALS AND
 MEDIAN BY OTHERS.



FILE NAME =	USER NAME = paul	DESIGNED - ESW	REVISED -	STATE OF ILLINOIS DEPARTMENT OF TRANSPORTATION	DELINATOR DETAIL, FAYETTE AVENUE	F.A.I. RTE.	SECTION	COUNTY	TOTAL SHEETS	SHEET NO.	
6/24/2010		DRAWN - PDB	REVISED -			57/70	(25-3)I-6	EFFINGHAM	839	327	
PLOT SCALE = 200.0000' / IN.		CHECKED - BRM	REVISED -			CONTRACT NO. 74293					
PLOT DATE = 6/24/2010		DATE - 11-06-08	REVISED -			ILLINOIS FED. AID PROJECT					

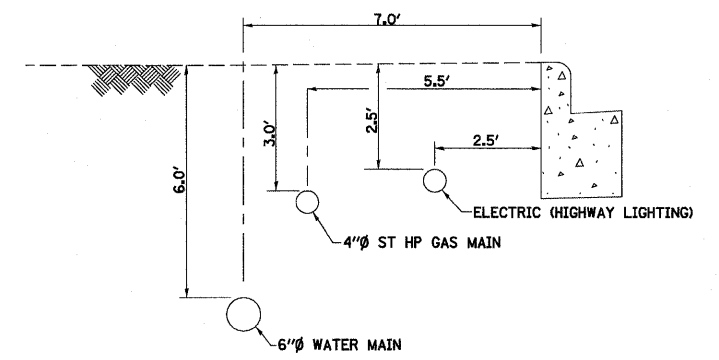
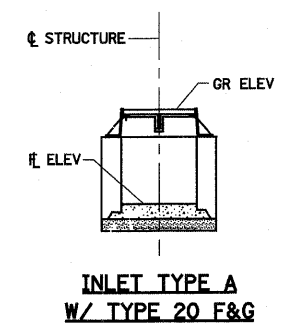
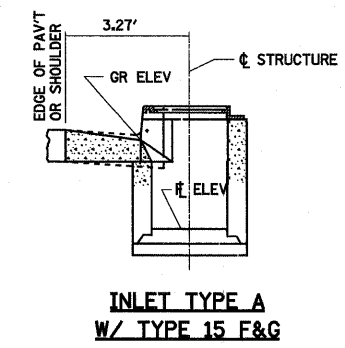
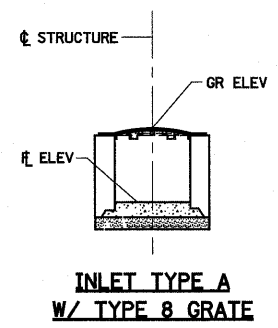
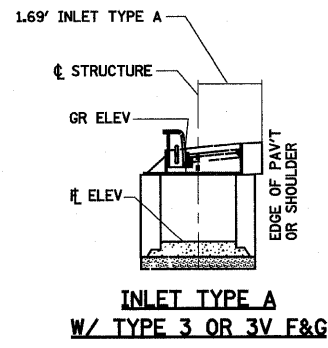

UTILITY SECTION AT LT. STA 70+80.00

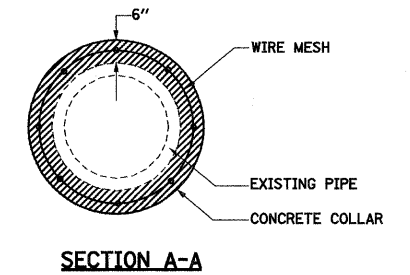
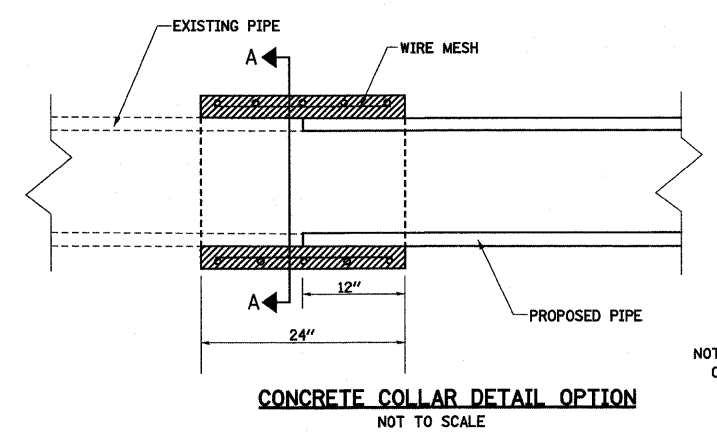
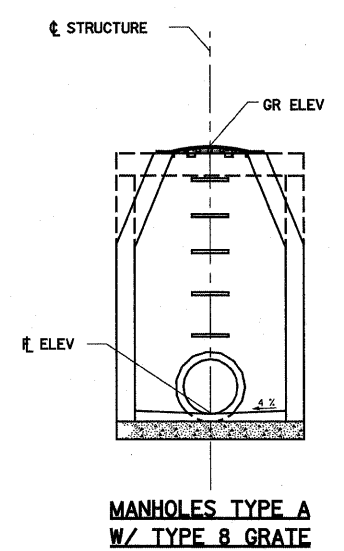
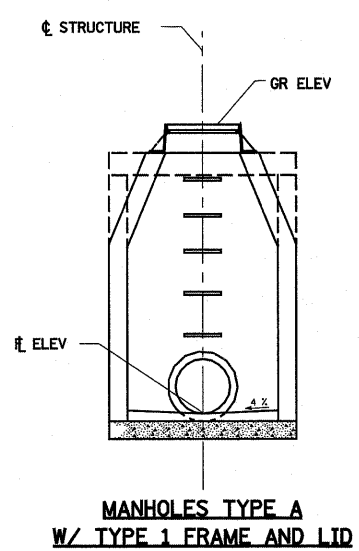
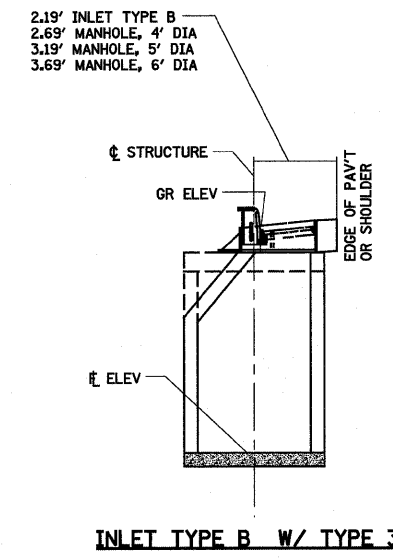

NOTE:
CLASS SI CONCRETE SHALL BE USED.

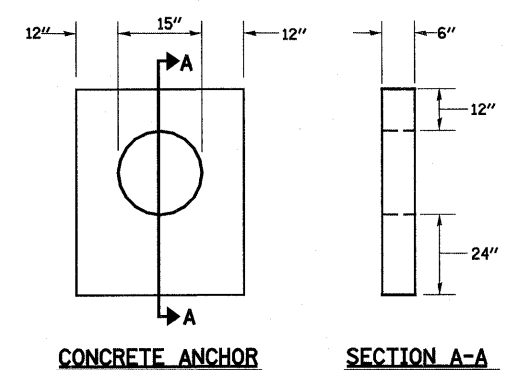
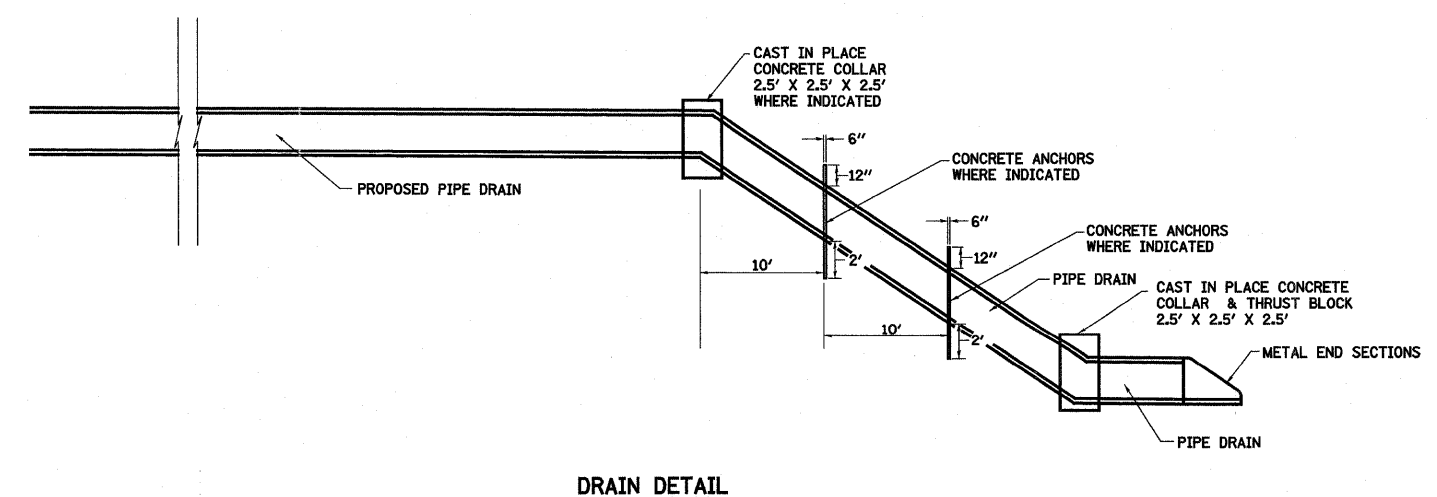

FILE NAME =	USER NAME = paul	DESIGNED - JWS	REVISED -	STATE OF ILLINOIS DEPARTMENT OF TRANSPORTATION	MISCELLANEOUS DETAILS		F.A.I. RTE.	SECTION	COUNTY	TOTAL SHEETS	SHEET NO.
S:\Projects\403-00072-51-70\dgn\miscellaneous\miscellaneous.dgn	PLOT SCALE = 100.0000' / IN.	DRAWN - PDB	REVISED -				57/70	(25-31I-6 & (25-3HB-2)B	EFFINGHAM	839	328
	PLOT DATE = 6/24/2018	CHECKED - BRM	REVISED -		SCALE: SHEET NO. 1 OF 1 SHEETS STA. TO STA.		FED. ROAD DIST. NO. ILLINOIS FED. AID PROJECT		CONTRACT NO. 74293		
		DATE - 11-05-07	REVISED -								

STATE OF ILLINOIS
DEPARTMENT OF TRANSPORTATION

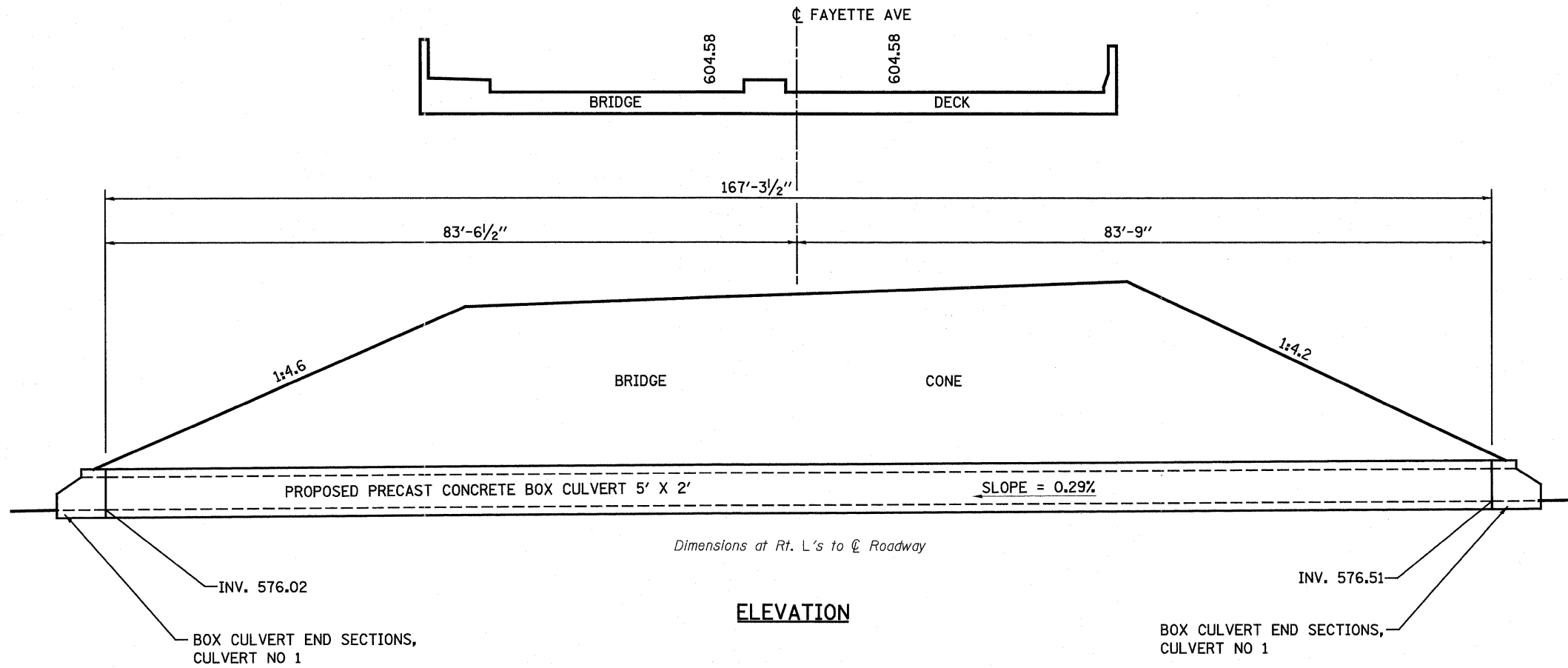

ELEVATION

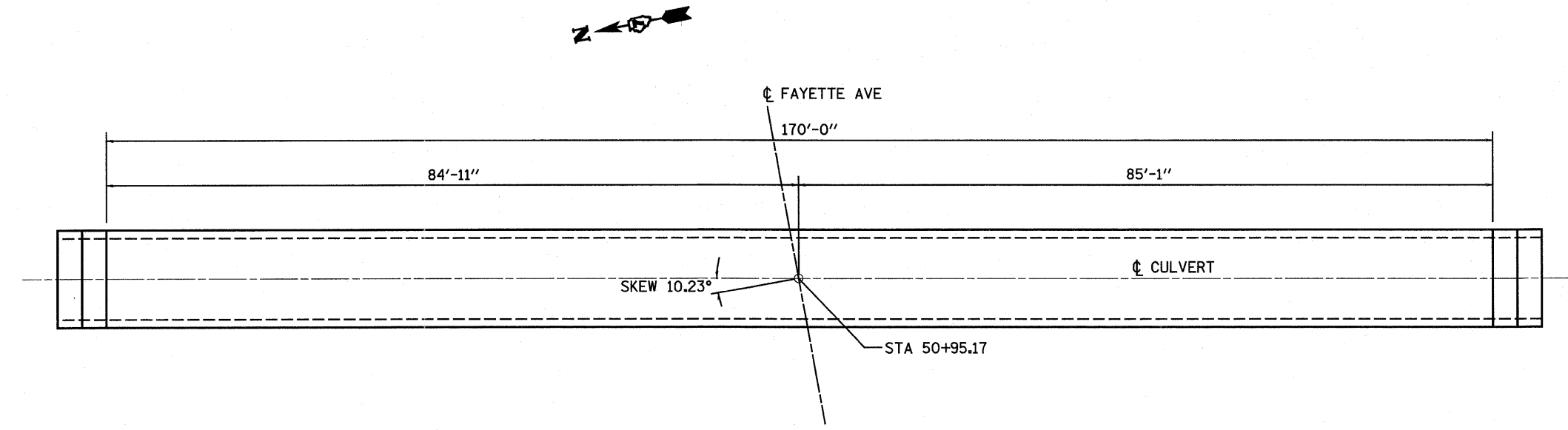

PLAN

DESIGNED	-	RCB
CHECKED	-	JWS
DRAWN	-	RCB
CHECKED	-	BRM

BOX CULVERT DETAILS
PRECAST CONCRETE BOX CULVERT
STA 50+95.17
FAYETTE AVENUE

SHEET NO. 1 OF 1 SHEETS	F.A.I. RTE.	SECTION	COUNTY	TOTAL SHEETS	SHEET NO.
	57/70	(25-3)I-6	EFFINGHAM	839	329
			CONTRACT NO. 74293		
FED. ROAD DIST. NO.		ILLINOIS FED. AID PROJECT			

Bench Mark: Chiseled "□" on east crash wall under Fayette Avenue on North Bound of I-57/70 Sta. 2146+48.00 65 Rt. Elev. 583.44

Existing Structure: #025-0023 Built in 1960 as F.A.I. Route 7 Section 25-3HB-1 & 25-3HF-1. 251'-0" Bk. to Bk. of abutments and 65'-8" Out to Out Width. The structure consists of an R.C. deck on WF beams with 2 spans continuous and 2 simple end spans supported on pile bent spill through abutments and on reinforced concrete columns with spread footing. Traffic to be maintained at all times utilizing stage construction.

No salvage.

STATE OF ILLINOIS
DEPARTMENT OF TRANSPORTATION

** See Sheet 3 of 38 for Transverse Limits of Protective Shield.

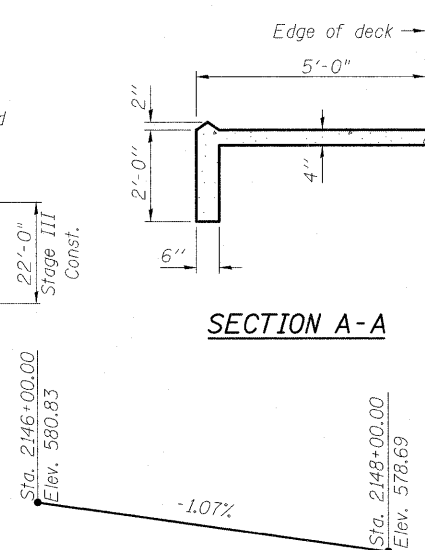
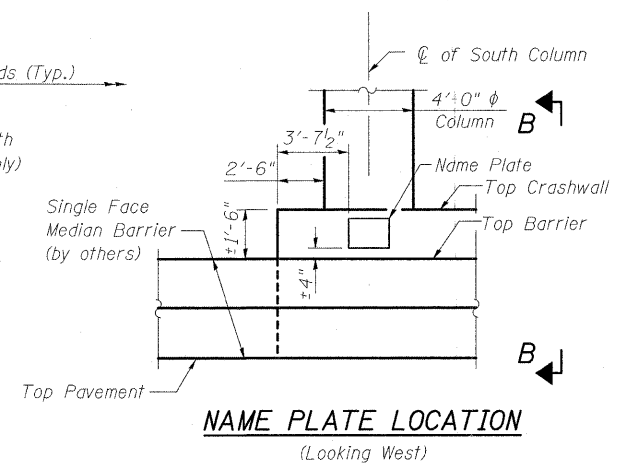
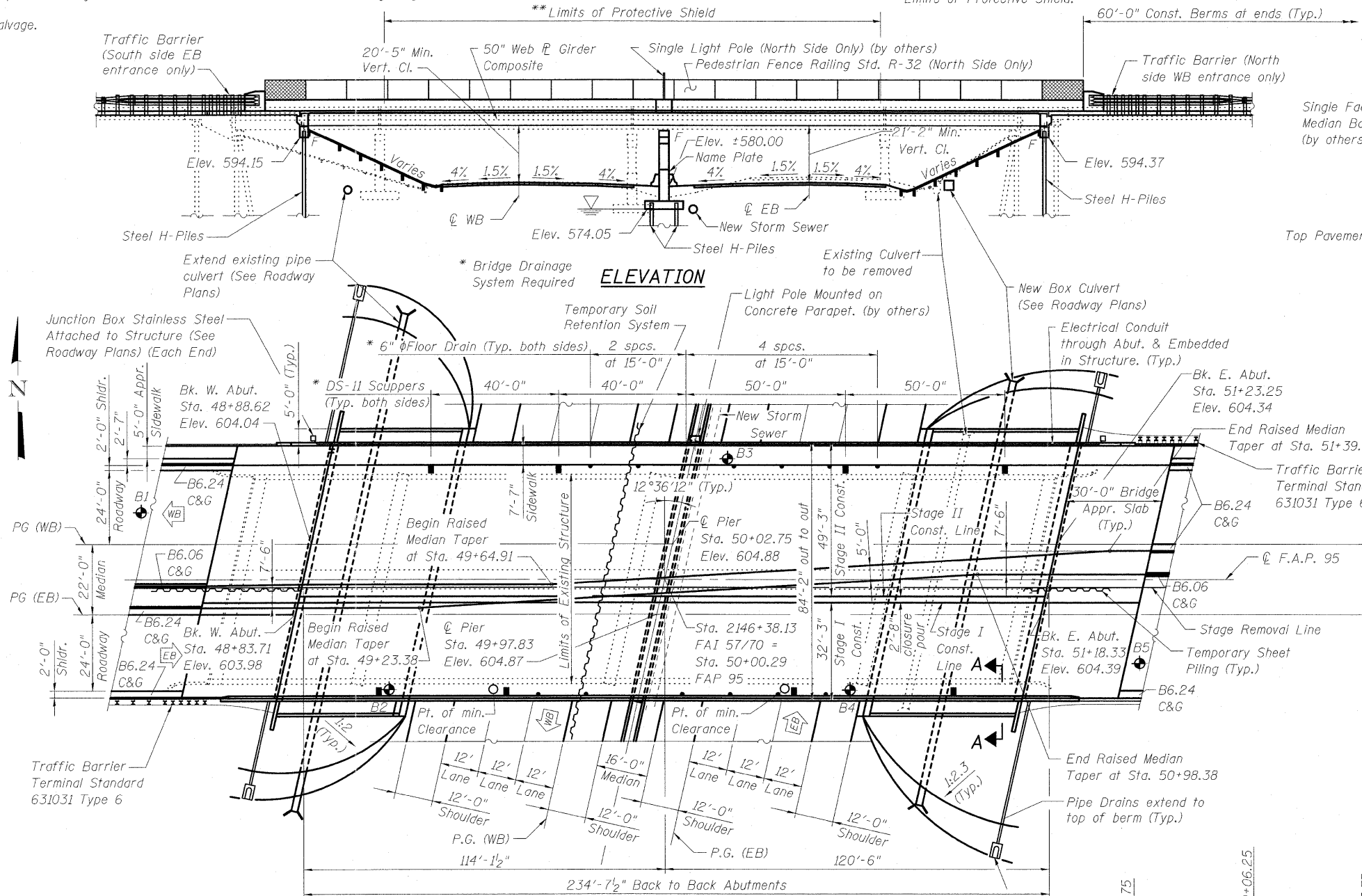

PROFILE GRADE
(EB & WB F.A.I. I-57/70 Route 70)

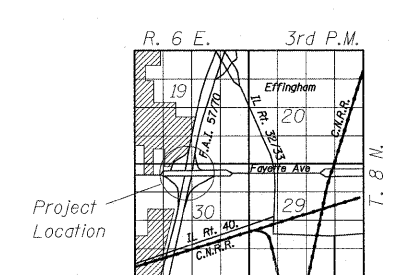

LOCATION SKETCH

INDEX OF SHEETS

1. General Plan & Elevation
2. General Data
3. Stage Construction Details
4. Temporary Shoring Details
5. Temporary Concrete Barrier for Stage Construction
- 6.-11. Top of Slab Elevations
12. West Approach Pavement Top of Slab Elevations
13. East Approach Pavement Top of Slab Elevations
- 14.-15. Superstructure
- 16.-17. Superstructure Details
18. Bridge Fence Railing Parapet Mounted
19. Concrete Parapet Slipforming Option
20. Drainage Scupper, DS-II
- 21.-22. Drainage System
23. West Bridge Approach Slab Details
24. East Bridge Approach Slab Details
25. Bridge Approach Slab Details
26. West Abutment Diaphragm Details
27. East Abutment Diaphragm Details
28. Structural Steel
29. Structural Steel & Bearing Details
- 29B. Structural Steel Crossframe Details
30. West Abutment Details
31. East Abutment Details
- 32.-32B. Pier Details
33. HP Pile Details
34. Bar Splicer Assembly & Mechanical Splicer Details
- 35.-38. Boring Logs

LOADING HL-93

Allow 50#/sq. ft. for future wearing surface.

DESIGN SPECIFICATIONS

2007 AASHTO LRFD Bridge Design Specifications
4th edition with 2008 and 2009 Interims

DESIGN STRESSES

FIELD UNITS

$f'_c = 3,500$ psi
 $f_y = 60,000$ psi (Reinforcement)
 $f_y = 50,000$ psi (M270 Grade 50) primary members
 $f_y = 36,000$ psi (M270 Grade 36)

SEISMIC DATA

Seismic Performance Zone (SPZ) = 1
 Design Spectral Acceleration at 1.0 sec. (S_{D1}) = 0.15
 Design Spectral Acceleration at 0.2 sec. (S_{D5}) = 0.36
 Soil Site Class = C

STATION 2146+38.13
 BUILT 20__ BY
 STATE OF ILLINOIS
 F.A.I. 57/70 SEC. (25-3HB-2)B
 LOADING HL-93
 STR. NO. 025-0106

NAME PLATE

See Std. 515001

GENERAL PLAN & ELEVATION

FAYETTE AVENUE OVER

F.A.I. ROUTE 57/70

F.A.P.-95 SECTION (25-3B-2)B

EFFINGHAM COUNTY

STATION 2146+38.13

STRUCTURE NO. 025-0106

APPROVED
FOR STRUCTURAL ADEQUACY ONLY

Robert E. Anderson (TDP)
ENGINEER OF BRIDGES AND STRUCTURES

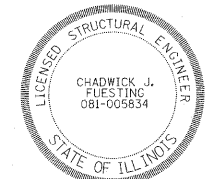

EXP. 11-30-2010
Chadwick J. Flesting
8/12/2010

DESIGNED	A.C.S.
CHECKED	B.B.
DRAWN	W.J.S.
CHECKED	C.J.F.

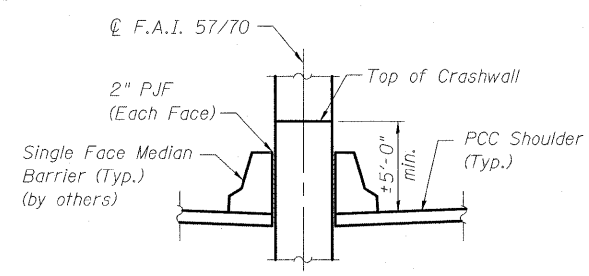

SECTION B-B

Illinois Design Firm Number 184.001670

BERNARDIN
LOCHMUELLER &
ASSOCIATES, INC.



3 Oak Drive
Maryville, IL 62452-5655
Local (618) 338-4665
Fax 618-338-4666

SHEET NO. 1 38 SHEETS	F.A.I. RTE. 57/70	SECTION (25-3HB-2)B	COUNTY EFFINGHAM	TOTAL SHEETS 839	SHEET NO. 330
	SN 025-0106		CONTRACT NO. 74293		
FED. ROAD DIST. NO. 7 ILLINOIS FED. AID PROJECT					

18029-43 AM 8/12/2010 10:25:05:10:57:01:0:0:0

STATE OF ILLINOIS
DEPARTMENT OF TRANSPORTATION

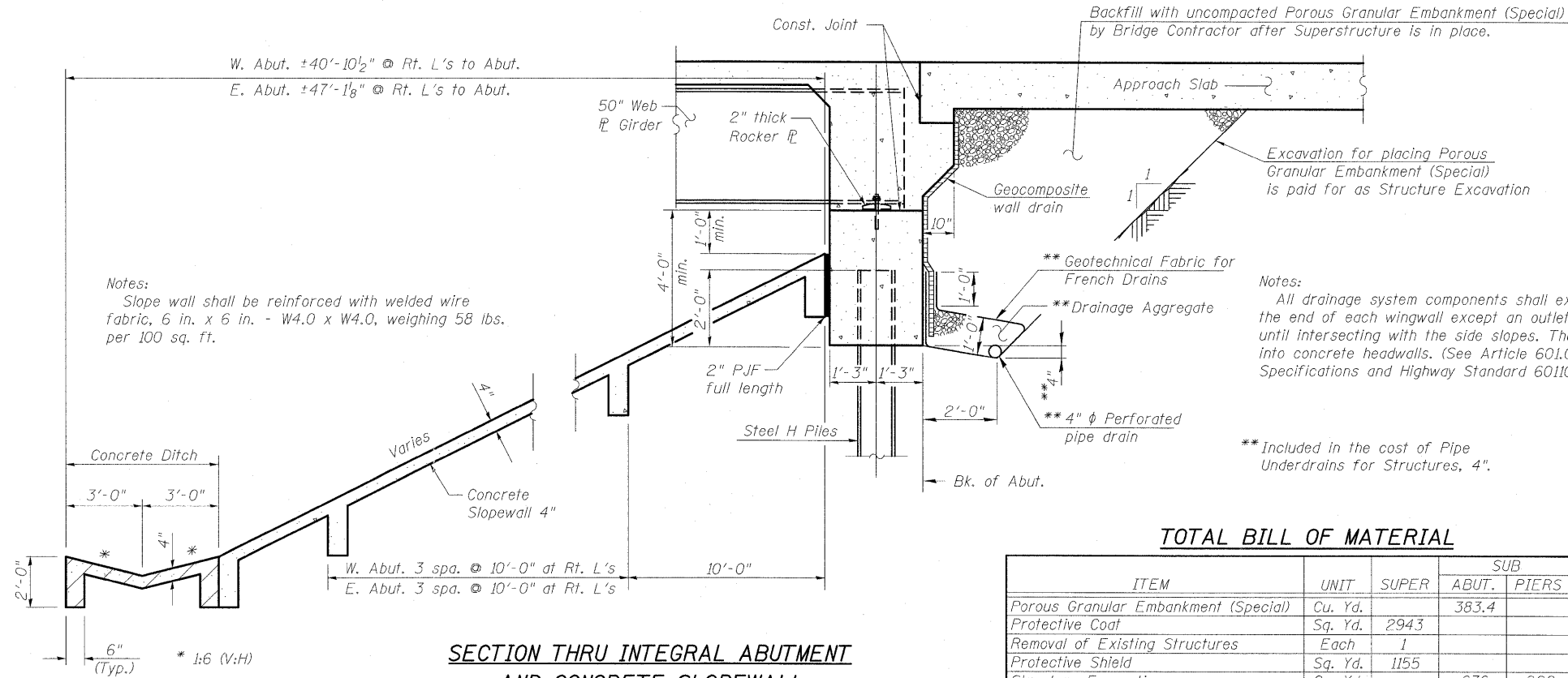

**SECTION THRU INTEGRAL ABUTMENT
AND CONCRETE SLOPEWALL**

(Horiz. dim. @ Rt. L's)

Concrete Ditch by Others

GENERAL NOTES

Fasteners shall be AASHTO M164 Type 1, mechanically galvanized bolts. Bolts $\frac{7}{8}$ in. ϕ , holes $\frac{15}{16}$ in. ϕ , unless otherwise noted.
Calculated weight of Structural Steel = 597,101 pounds (M270 Grade 50), 38,070 pounds (M270 Grade 36).

No field welding is permitted except as specified in the contract documents. Reinforcement bars shall conform to the requirements of ASTM A 706 Gr 60. See Special Provisions.

Reinforcement bars designated (E) shall be epoxy coated.

If the Contractor elects to use cantilever forming brackets on the exterior beams or girders, the brackets shall be placed at the same locations as required for the hardwood blocks in Article 503.06(b) of the Standard Specifications. If additional cantilever forming brackets are required, hardwood blocking shall be wedged between the exterior and first interior beam at each of these additional bracket locations.

Bearing seat surfaces shall be constructed or adjusted to the designated elevations within a tolerance of $\frac{1}{8}$ inch (0.01 ft.). Adjustment shall be made either by grinding the surface or by shimming the bearings.

The existing structural steel coating contains lead. The Contractor shall take appropriate precautions to deal with the presence of lead on this project.

The Inorganic Zinc Rich Primer / Acrylic / Acrylic Paint System shall be used for shop and field painting of new structural steel except where otherwise noted. The color of the final finish coat for all interior steel surfaces shall be gray, Munsell No. 5B 7/1. The color of the final finish coat for the exterior and bottom flange of the fascia beams shall be Gray, Munsell No. 5B 7/1. See Special Provision for "Cleaning and Painting New Metal Structures".

The embankment configuration shown shall be the minimum that must be placed and compacted prior to construction of the abutments.

Slipforming of North Parapet is not allowed.

Slipforming of 57/70 Median Parapets is not allowed.

Concrete Sealer shall be applied to the designated areas of the pier.

TOTAL BILL OF MATERIAL

ITEM	UNIT	SUPER	SUB		TOTAL
			ABUT.	PIERS	
Porous Granular Embankment (Special)	Cu. Yd.		383.4		383.4
Protective Coat	Sq. Yd.	2943			2943
Removal of Existing Structures	Each	1			1
Protective Shield	Sq. Yd.	1155			1155
Structure Excavation	Cu. Yd.		636	228	864
Floor Drains	Each	12			12
Concrete Structures	Cu. Yd.		134.2	260.2	394.4
Concrete Superstructure	Cu. Yd.	982.9			982.9
Bridge Deck Grooving	Sq. Yd.	2342			2342
Concrete Encasement	Cu. Yd.		12		12
Furnishing and Erecting Structural Steel	L. Sum	1			1
Stud Shear Connectors	Each	7740			7740
Reinforcement Bars, Epoxy Coated	Pound	225740	13920	43705	283365
Bar Splicers	Each	2204	31	73	2308
Bridge Fence Railing	Foot	257			257
Slope Wall, 4 Inch	Sq. Yd.		898		898
Furnishing Steel Piles HP 12x63	Foot		1200	884	2084
Driving Piles	Foot		1200	884	2084
Test Pile Steel, HP 12x63	Each		4	2	6
Pile Shoes	Each		30	26	56
Temporary Sheet Piling	Sq. Ft.		1429		1429
Name Plates	Each	1			1
Anchor Bolts, 1"	Each		40		40
Anchor Bolts, 1 1/4"	Each			20	20
Concrete Sealer	Sq. Ft.			2573	2573
Geocomposite Wall Drain	Sq. Yd.		179.1		179.1
Pipe Underdrains for Structures, 4"	Foot		202		202
Drainage System	L. Sum	1			1
Drainage Scuppers, DS-11	Each	8			8
Temporary Soil Retention System	Sq. Ft.			687	687
Mechanical Splicers	Each			482	482
Temporary Support System	L. Sum			1	1

DESIGNED	A.C.S.
CHECKED	B.B.
DRAWN	W.J.S.
CHECKED	C.J.F.

GENERAL DATA
STRUCTURE NO. 025-0106



**BERNARDIN
LOCHMUELLER &
ASSOCIATES, INC.**

3 Oak Drive
Maryville, IL 62462-5685
Local (618) 368-4005
Fax 618-368-4666

SHEET NO. 2	F.A.I. RTE.	SECTION	COUNTY	TOTAL SHEETS	SHEET NO.
	57/70	(25-3HB-2)B	EFFINGHAM	839	331
38 SHEETS	SN 025-0106		CONTRACT NO. 74293		
FED. ROAD DIST. NO. 7 ILLINOIS FED. AID PROJECT					

STATE OF ILLINOIS
DEPARTMENT OF TRANSPORTATION

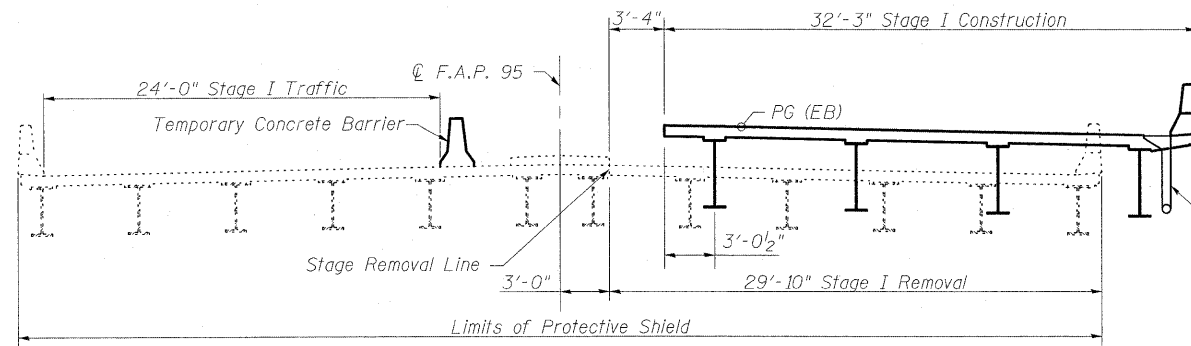

STAGE I CONSTRUCTION
(Looking East)

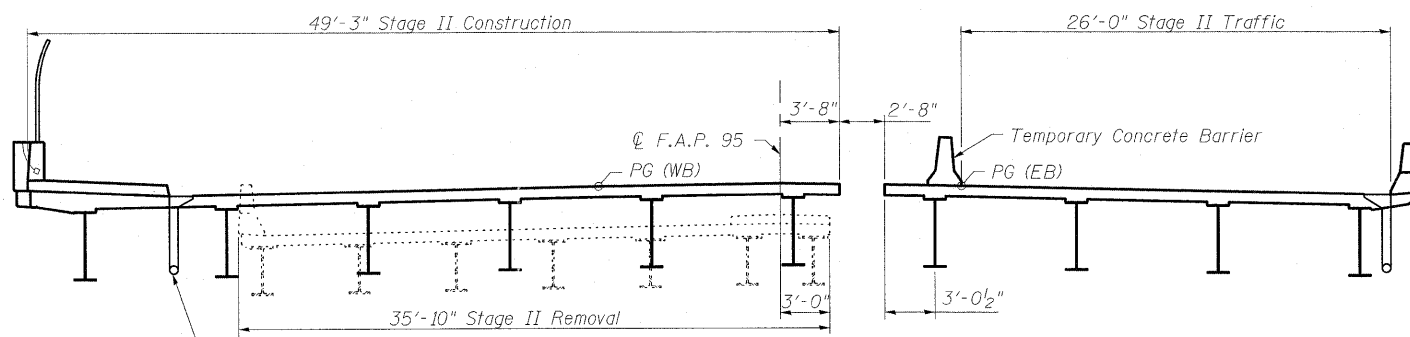

STAGE II CONSTRUCTION
(Looking East)

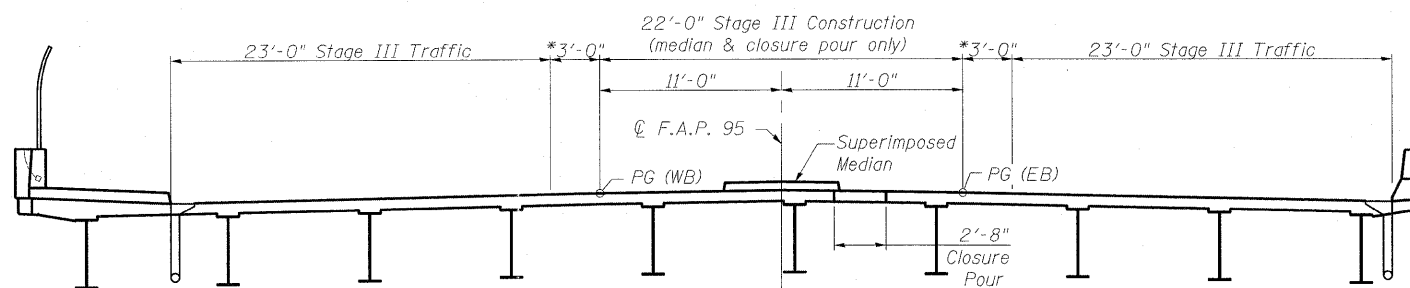

* Temporary Barriers Required See Roadway Plans for type & location.
STAGE III CONSTRUCTION
(Looking East)

Drainage Scupper DS-II or Floor Drain with Bridge Drainage System. (Typ.)

Temporary Soil Retention System Stage I. See Sheet 4 of 38 for Elevation View

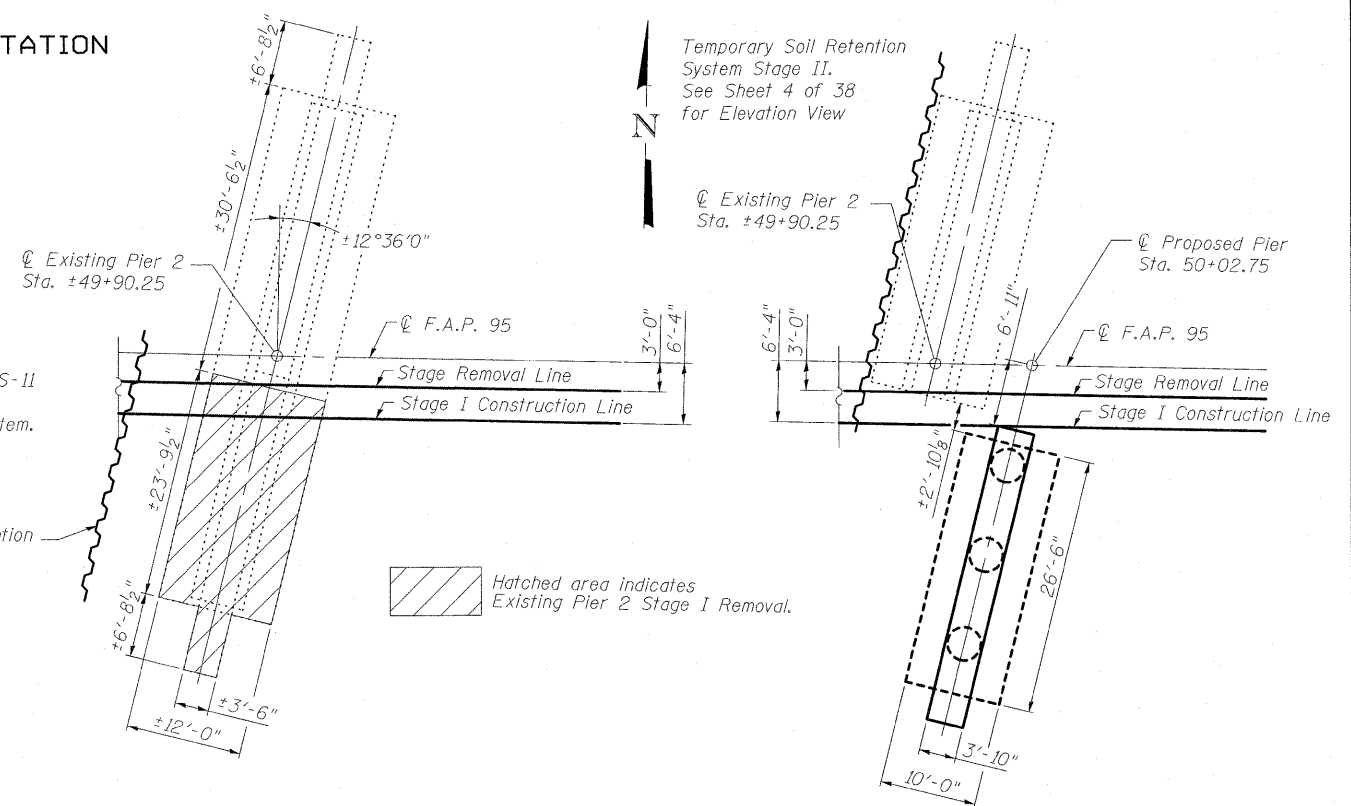

EXISTING PIER 2
STAGE I REMOVAL

NEW PIER
STAGE I CONSTRUCTION

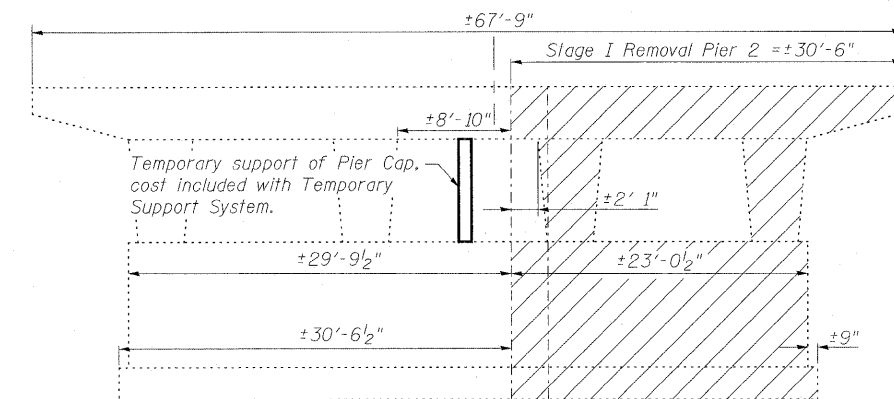

EXISTING PIER 2
STAGE I REMOVAL

STAGE CONSTRUCTION DETAILS
STRUCTURE NO. 025-0106

DESIGNED	A.C.S.
CHECKED	B.B.
DRAWN	W.J.S.
CHECKED	C.J.F.



**BERNARDIN
LOCHMUELLER &
ASSOCIATES, INC.**

3 Oak Drive
Maryville, IL 62052-5655
Local (618) 398-4665
Fax 618-288-4666

SHEET NO. 3 38 SHEETS	F.A.I. RTE.	SECTION	COUNTY	TOTAL SHEETS	SHEET NO.
	57/70	(25-3HB-2)B	EFFINGHAM	839	332
SN 025-0106			CONTRACT NO. 74293		
FED. ROAD DIST. NO. 7 ILLINOIS FED. AID PROJECT					

STATE OF ILLINOIS
DEPARTMENT OF TRANSPORTATION

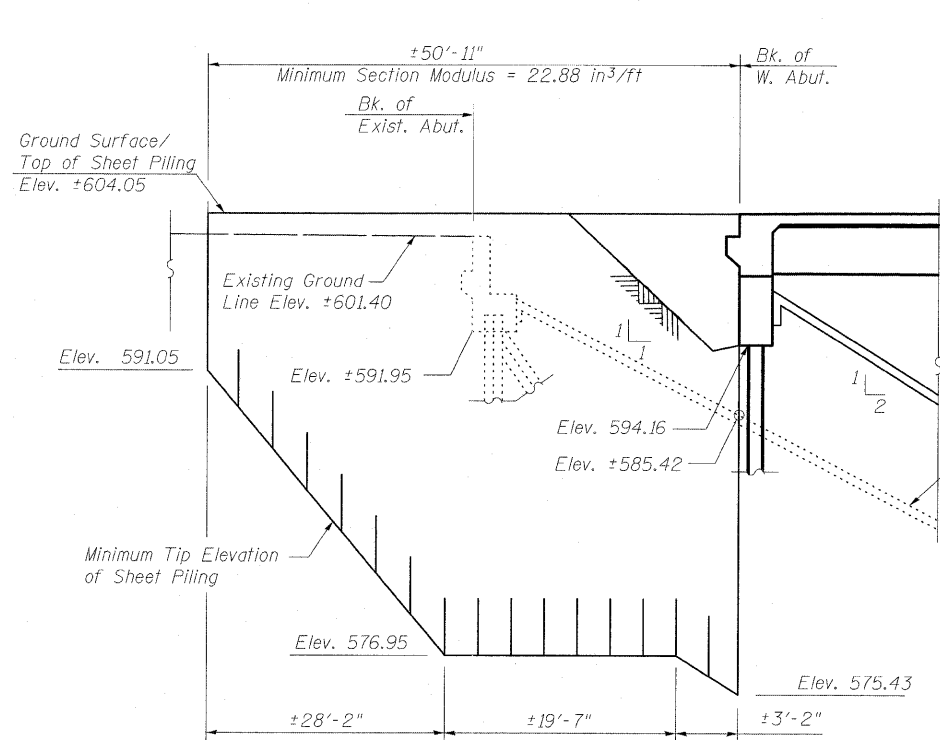

WEST ABUTMENT SHEET PILING ELEVATION

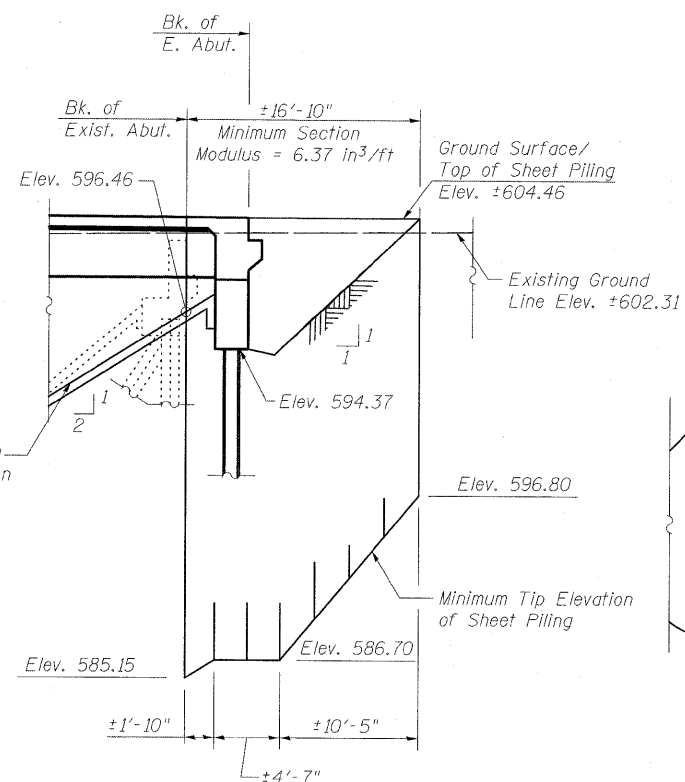

EAST ABUTMENT SHEET PILING ELEVATION

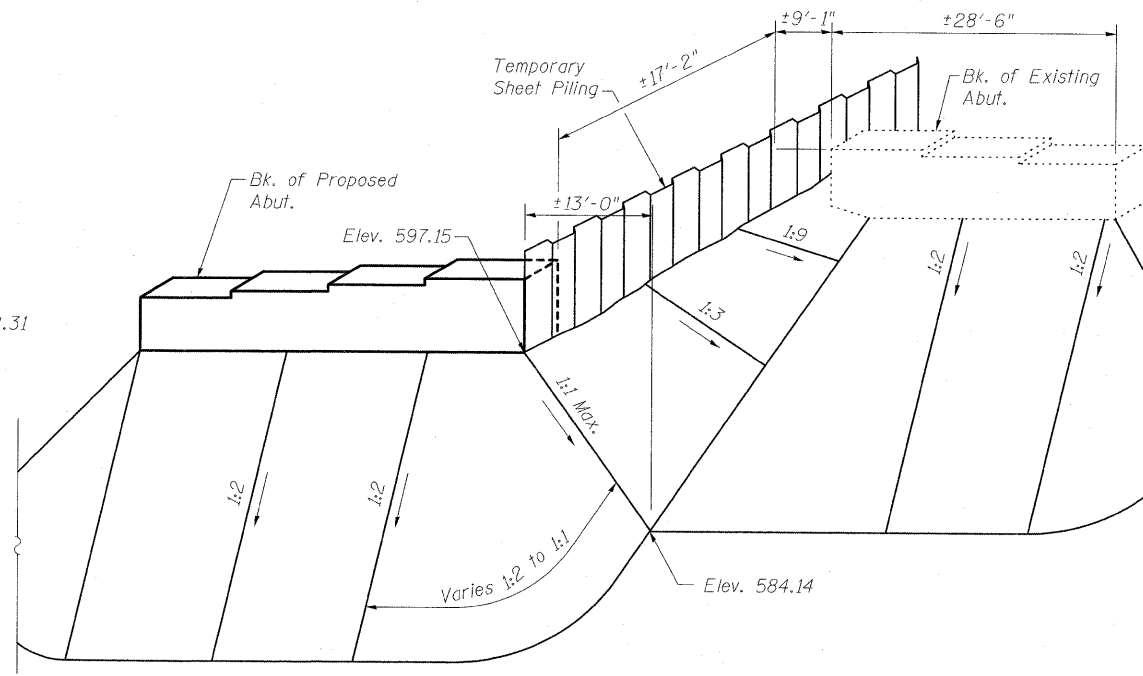

WEST ABUTMENT STAGE I
(Showing Soil Slopes)
(Slope East Abutment soil as needed)

TEMPORARY SHEET PILING ELEVATION

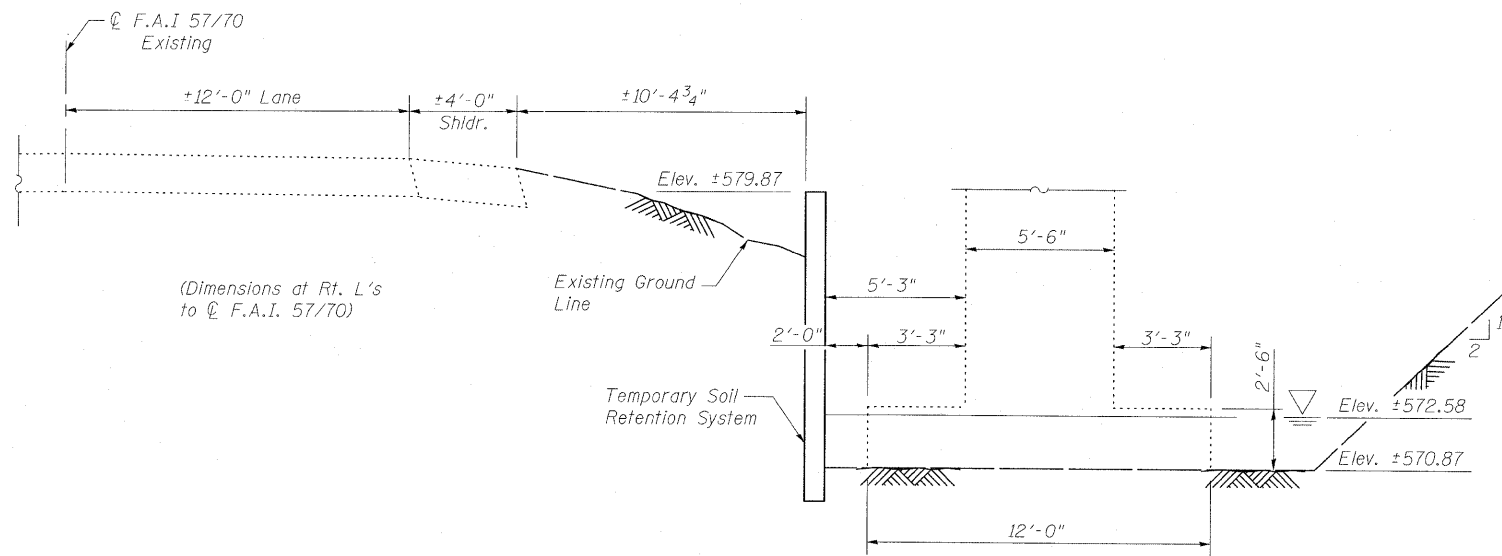

SECTION A-A

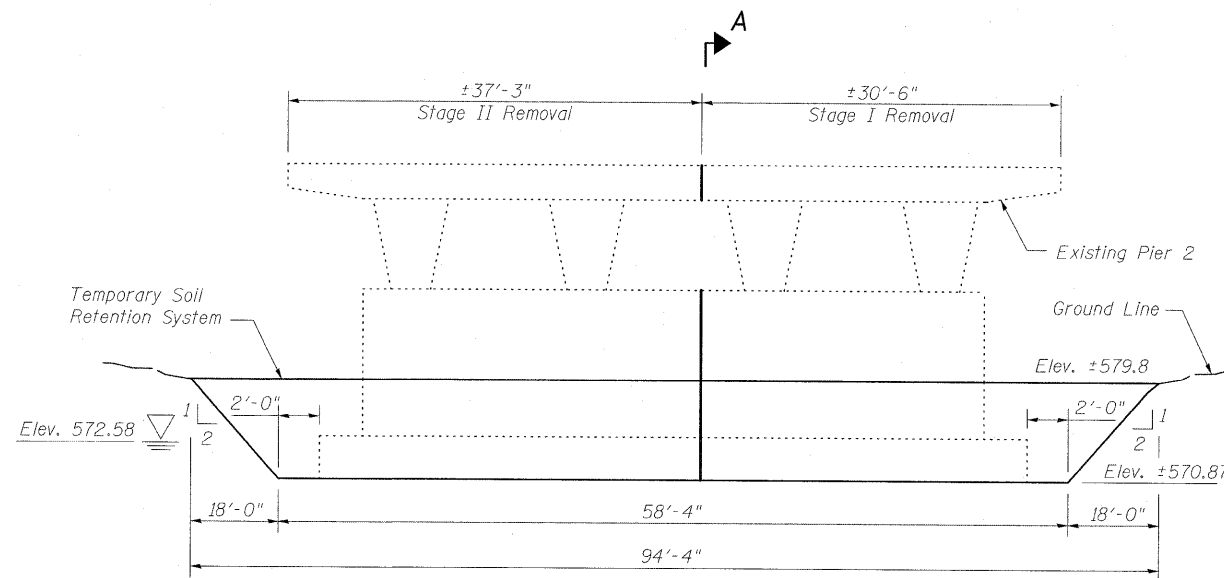

TEMPORARY SOIL RETENTION SYSTEM ELEVATION
(Looking East)

BILL OF MATERIAL

Item	Unit	Quantity
Temporary Sheet Piling	Sq. Ft.	1429
Temporary Soil Retention System	Sq. Ft.	687

TEMPORARY SHORING DETAILS
STRUCTURE NO. 025-0106

Notes:
If the Contractor chooses to alter the temporary cantilevered sheet piling design requirements shown on the plans, a design submittal including plan details and calculations will be required for review and acceptance by the Engineer.
For the Pier, the cantilevered sheet piling design does not appear feasible and additional members or other retention systems may be necessary. The Contractor shall submit a temporary soil retention system design including plan details and calculations for review and acceptance by the Engineer.

DESIGNED	A.C.S.
CHECKED	B.B.
DRAWN	W.J.S.
CHECKED	C.J.F.



**BERNARDIN
LOCHMUELLER &
ASSOCIATES, INC.**

3 Oak Drive
Mareville, IL 62968-5605
Local (618) 288-4665
Fax 618-288-4666

SHEET NO. 4 38 SHEETS	F.A.I. RTE.	SECTION	COUNTY	TOTAL SHEETS	SHEET NO.
	57/70	(25-3HB-2)B	EFFINGHAM	839	333
SN 025-0106			CONTRACT NO. 74293		
FED. ROAD DIST. NO. 7 ILLINOIS FED. AID PROJECT					

STATE OF ILLINOIS
DEPARTMENT OF TRANSPORTATION

When "A" is 3'-6" or less, the temporary concrete barrier shall be anchored to the new slab according to Detail I or Detail II. No anchorage is required when "A" is greater than 3'-6".

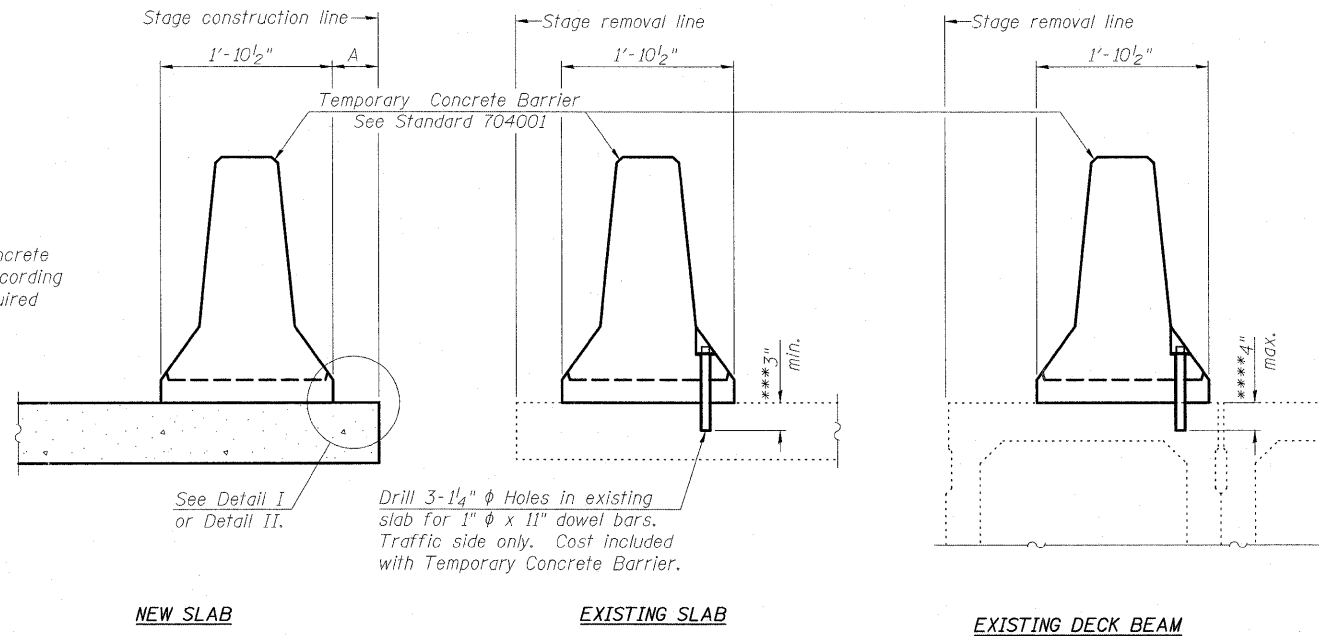

SECTIONS THRU SLAB OR DECK BEAM

NOTES

Detail I - With Bar Splicer or Couplers:
Connect one (1) 1"x7"x"W" steel \bar{L} to the top layer of couplers with 2-5/8" ϕ bolts screwed to coupler at approximate \bar{C} of each barrier panel.

Detail II - With Extended Reinforcement Bars:
Connect one (1) 1"x7"x"W" steel \bar{L} to the concrete slab or concrete wearing surface with 2-5/8" ϕ Expansion Anchors or cast in place inserts spaced between the top layer of reinforcement at approximate \bar{C} of each barrier panel.

Cost of anchorage is included with Temporary Concrete Barrier. The 1" x 7" x "W" plate shall not be removed until stage II construction forms and all reinforcement bars are in place and the concrete is ready to be placed.

*** Dimension shown is minimum required embedment into concrete. If hot-mix asphalt wearing surface is present, minimum embedment shall be in addition to wearing surface depth.

**** If existing deck beam is to remain in place after stage construction, embedment shall only be into wearing surface and not into existing deck beam concrete.

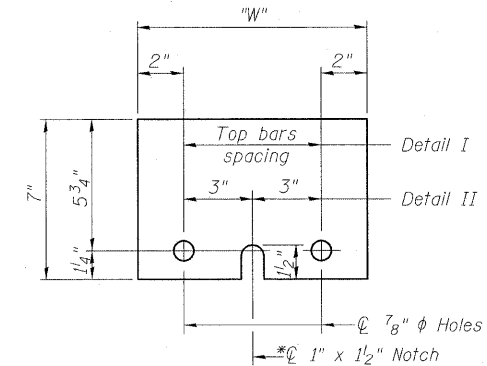
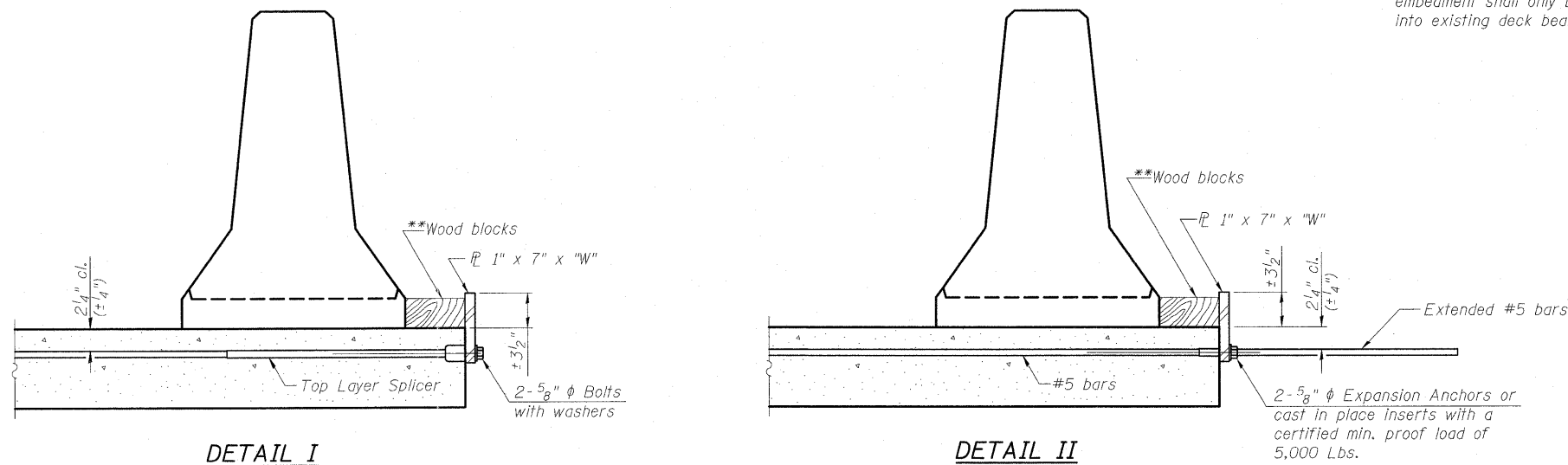

STEEL RETAINER \bar{L} 1" x 7" x "W"

* Required only with Detail II

** Wood blocks may be omitted when required to provide minimum stage traffic lane width. When the wood blocks are omitted, the concrete barrier shall be in direct contact with the steel retainer plate.

"W" = Top bar spacing = 4"

DESIGNED	-
CHECKED	-
DRAWN	W.J.S.
CHECKED	C.J.F.

R-27

11-1-09



BERNARDIN
LOCHMUELLER &
ASSOCIATES, INC.

3 Oak Drive
Mareville, IL 62062-2635
Local-(618) 288-4665
Fax 618-288-4666

SHEET NO. 5 38 SHEETS	F.A.I. RTE.	SECTION	COUNTY	TOTAL SHEETS	SHEET NO.
	57/70	(25-3HB-2)B	EFFINGHAM	839	334
SN 025-0106			CONTRACT NO. 74293		
FED. ROAD DIST. NO. 7 ILLINOIS FED. AID PROJECT					

TEMPORARY CONCRETE BARRIER
FOR STAGE CONSTRUCTION
STRUCTURE NO. 025-0106

STATE OF ILLINOIS
DEPARTMENT OF TRANSPORTATION

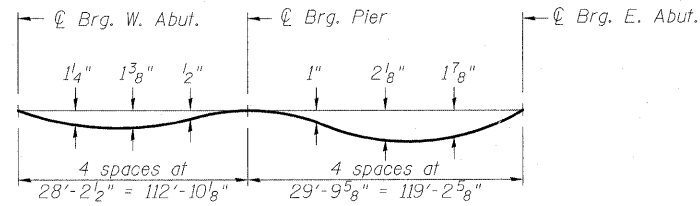

DEAD LOAD DEFLECTION DIAGRAM

(Includes weight of concrete only.)

Note:
The above deflections are not to be used in the field if the engineer is working from the "Theoretical Grade Elevations Adjusted for Dead Load Deflection" as shown below and on sheets 7 thru 11 of 38.

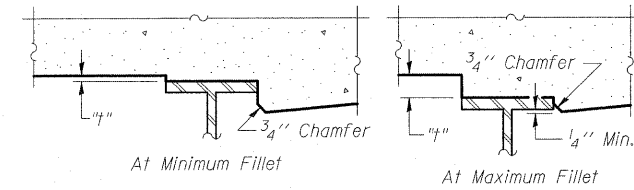

To determine "t": After all structural steel has been erected, elevations of the top flanges of the beams shall be taken at intervals shown below and on sheets 7 thru 11 of 38. These elevations subtracted from the "Theoretical Grade Elevations Adjusted for Dead Load Deflection" shown below and on sheets 7 thru 11 of 38, minus slab thickness, equals the fillet heights "t" above top flange of beams.

FILLET HEIGHTS

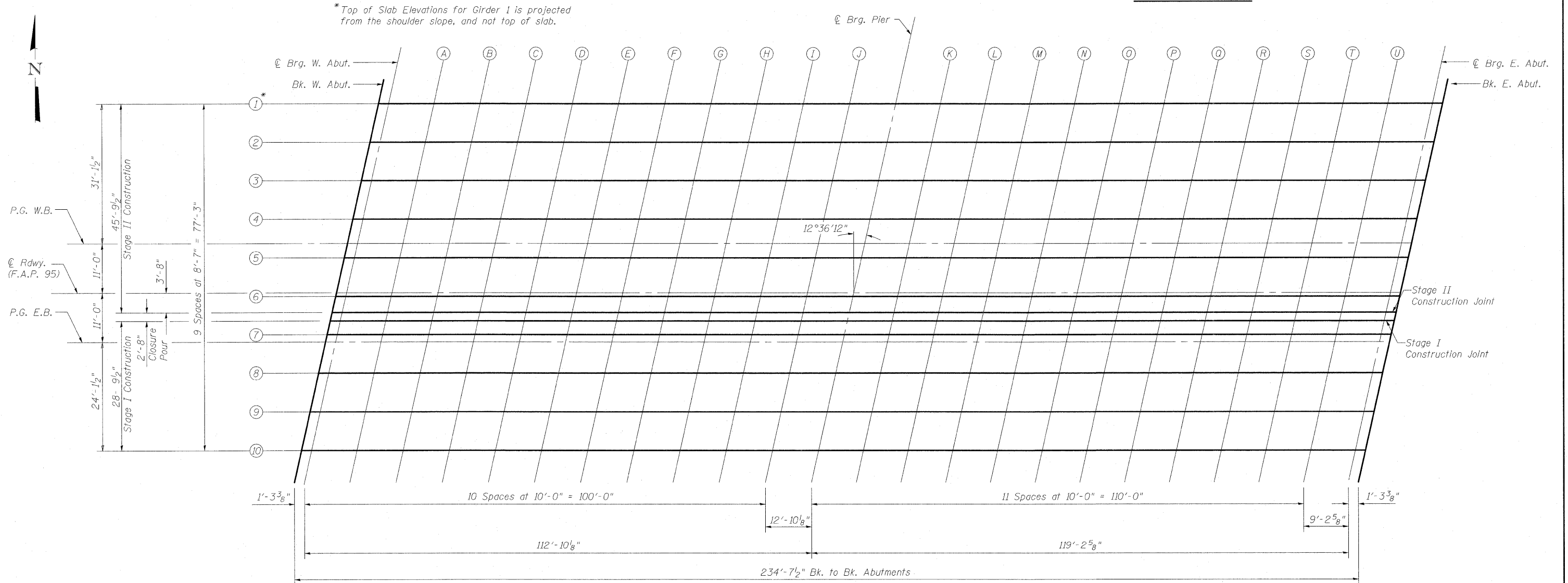

*Top of Slab Elevations for Girder 1 is projected from the shoulder slope, and not top of slab.

ELEVATION LOCATION PLAN

**TOP OF SLAB ELEVATIONS
STRUCTURE NO. 025-0106**

DESIGNED	A.C.S.
CHECKED	B.B.
DRAWN	W.J.S.
CHECKED	C.J.F.



**BERNARDIN
LOCHMUELLER &
ASSOCIATES, INC.**

3 Oak Drive
Maryville, IL 62432-5635
Local (618) 388-4665
Fax 618-288-4666

SHEET NO. 6 38 SHEETS	F.A.I. RTE.	SECTION	COUNTY	TOTAL SHEETS	SHEET NO.
	57/70	(25-3HB-2)B	EFFINGHAM	839	335
SN 025-0106			CONTRACT NO. 74293		
FED. ROAD DIST. NO. 7 ILLINOIS FED. AID PROJECT					

STATE OF ILLINOIS
DEPARTMENT OF TRANSPORTATION

Note: Top of Slab Elevations for Girder 1 is projected from the shoulder slope, and not top of slab.

Girder 1

Location	Station	Offset from $\text{\textcircled{C}}$ F.A.P. 95	Theoretical Grade Elevations	Theoretical Grade Elevations Adjusted For Dead Load Deflection
Bk. of W. Abutment	48+95.58	-42.12	603.48	603.48
$\text{\textcircled{C}}$ Bearing W. Abut.	48+96.86	-42.12	603.50	603.50
A	49+06.86	-42.12	603.62	603.65
B	49+16.86	-42.12	603.72	603.79
C	49+26.86	-42.12	603.82	603.92
D	49+36.86	-42.12	603.91	604.01
E	49+46.86	-42.12	603.98	604.09
F	49+56.86	-42.12	604.05	604.15
G	49+66.86	-42.12	604.11	604.18
H	49+76.86	-42.12	604.15	604.21
I	49+86.86	-42.12	604.19	604.22
J	49+96.86	-42.12	604.22	604.24
$\text{\textcircled{C}}$ Bearing Pier	50+09.71	-42.12	604.24	604.24
K	50+19.71	-42.12	604.24	604.27
L	50+29.71	-42.12	604.24	604.29
M	50+39.71	-42.12	604.22	604.30
N	50+49.71	-42.12	604.19	604.31
O	50+59.71	-42.12	604.16	604.30
P	50+69.71	-42.12	604.11	604.29
Q	50+79.71	-42.12	604.06	604.22
R	50+89.71	-42.12	603.99	604.15
S	50+99.71	-42.12	603.91	604.06
T	51+09.71	-42.12	603.83	603.93
U	51+19.71	-42.12	603.73	603.78
$\text{\textcircled{C}}$ Bearing E. Abut.	51+28.93	-42.12	603.64	603.64
Bk. of E. Abutment	51+30.21	-42.12	603.62	603.62

Girder 2

Location	Station	Offset from $\text{\textcircled{C}}$ F.A.P. 95	Theoretical Grade Elevations	Theoretical Grade Elevations Adjusted For Dead Load Deflection
Bk. of W. Abutment	48+93.66	-33.54	603.64	603.64
$\text{\textcircled{C}}$ Bearing W. Abut.	48+94.95	-33.54	603.65	603.65
A	49+04.95	-33.54	603.77	603.81
B	49+14.95	-33.54	603.88	603.95
C	49+24.95	-33.54	603.98	604.08
D	49+34.95	-33.54	604.07	604.17
E	49+44.95	-33.54	604.15	604.26
F	49+54.95	-33.54	604.22	604.32
G	49+64.95	-33.54	604.28	604.35
H	49+74.95	-33.54	604.32	604.38
I	49+84.95	-33.54	604.36	604.40
J	49+94.95	-33.54	604.39	604.41
$\text{\textcircled{C}}$ Bearing Pier	50+07.79	-33.54	604.41	604.41
K	50+17.79	-33.54	604.42	604.45
L	50+27.79	-33.54	604.42	604.47
M	50+37.79	-33.54	604.40	604.48
N	50+47.79	-33.54	604.38	604.49
O	50+57.79	-33.54	604.34	604.49
P	50+67.79	-33.54	604.30	604.47
Q	50+77.79	-33.54	604.25	604.41
R	50+87.79	-33.54	604.18	604.34
S	50+97.79	-33.54	604.11	604.26
T	51+07.79	-33.54	604.02	604.12
U	51+17.79	-33.54	603.93	603.98
$\text{\textcircled{C}}$ Bearing E. Abut.	51+27.01	-33.54	603.83	603.83
Bk. of E. Abutment	51+28.29	-33.54	603.82	603.82

Girder 3

Location	Station	Offset from $\text{\textcircled{C}}$ F.A.P. 95.	Theoretical Grade Elevations	Theoretical Grade Elevations Adjusted For Dead Load Deflection
Bk. of W. Abutment	48+91.75	-24.96	603.79	603.79
$\text{\textcircled{C}}$ Bearing W. Abut.	48+93.03	-24.96	603.81	603.81
A	49+03.03	-24.96	603.93	603.97
B	49+13.03	-24.96	604.04	604.11
C	49+23.03	-24.96	604.14	604.24
D	49+33.03	-24.96	604.23	604.34
E	49+43.03	-24.96	604.31	604.42
F	49+53.03	-24.96	604.38	604.48
G	49+63.03	-24.96	604.44	604.52
H	49+73.03	-24.96	604.50	604.55
I	49+83.03	-24.96	604.54	604.57
J	49+93.03	-24.96	604.57	604.58
$\text{\textcircled{C}}$ Bearing Pier	50+05.87	-24.96	604.59	604.59
K	50+15.87	-24.96	604.60	604.63
L	50+25.87	-24.96	604.60	604.65
M	50+35.87	-24.96	604.59	604.66
N	50+45.87	-24.96	604.56	604.67
O	50+55.87	-24.96	604.53	604.67
P	50+65.87	-24.96	604.49	604.66
Q	50+75.87	-24.96	604.44	604.60
R	50+85.87	-24.96	604.37	604.53
S	50+95.87	-24.96	604.30	604.45
T	51+05.87	-24.96	604.22	604.32
U	51+15.87	-24.96	604.13	604.17
$\text{\textcircled{C}}$ Bearing E. Abut.	51+25.09	-24.96	604.03	604.03
Bk. of E. Abutment	51+26.37	-24.96	604.02	604.02

DESIGNED	A.C.S.
CHECKED	B.B.
DRAWN	W.J.S.
CHECKED	C.J.F.



**BERNARDIN
LOCHMUELLER &
ASSOCIATES, INC.**

3 Oak Drive
Mareville, IL 62089-5685
Local (618) 298-4665
Fax 618-288-4666

**TOP OF SLAB ELEVATIONS
STRUCTURE NO. 025-0106**

SHEET NO. 7 38 SHEETS	F.A.I. RTE.	SECTION	COUNTY	TOTAL SHEETS	SHEET NO.
	57/70	(25-3HB-2)B	EFFINGHAM	839	336
SN 025-0106			CONTRACT NO. 74293		
FED. ROAD DIST. NO. 7 ILLINOIS FED. AID PROJECT					

STATE OF ILLINOIS
DEPARTMENT OF TRANSPORTATION

Girder 4

Location	Station	Offset from C.F.A.P. 95	Theoretical Grade Elevations	Theoretical Grade Elevations Adjusted For Dead Load Deflection
Bk. of W. Abutment	48+89.83	-16.38	603.95	603.95
C Bearing W. Abut.	48+91.11	-16.38	603.96	603.96
A	49+01.11	-16.38	604.09	604.12
B	49+11.11	-16.38	604.20	604.27
C	49+21.11	-16.38	604.30	604.40
D	49+31.11	-16.38	604.39	604.50
E	49+41.11	-16.38	604.48	604.59
F	49+51.11	-16.38	604.55	604.65
G	49+61.11	-16.38	604.61	604.69
H	49+71.11	-16.38	604.67	604.72
I	49+81.11	-16.38	604.71	604.74
J	49+91.11	-16.38	604.74	604.76
C Bearing Pier	50+03.95	-16.38	604.77	604.77
K	50+13.95	-16.38	604.78	604.80
L	50+23.95	-16.38	604.78	604.83
M	50+33.95	-16.38	604.77	604.85
N	50+43.95	-16.38	604.75	604.86
O	50+53.95	-16.38	604.72	604.86
P	50+63.95	-16.38	604.68	604.85
Q	50+73.95	-16.38	604.63	604.79
R	50+83.95	-16.38	604.57	604.72
S	50+93.95	-16.38	604.50	604.64
T	51+03.95	-16.38	604.42	604.51
U	51+13.95	-16.38	604.33	604.37
C Bearing E. Abut.	51+23.17	-16.38	604.23	604.23
Bk. of E. Abutment	51+24.45	-16.38	604.22	604.22

Profile Grade (W.B.)

Location	Station	Offset from C.F.A.P. 95	Theoretical Grade Elevations	Theoretical Grade Elevations Adjusted For Dead Load Deflection
Bk. of W. Abutment	48+88.62	-11.00	604.04	604.04
C Bearing W. Abut.	48+89.91	-11.00	604.06	604.06
A	48+99.91	-11.00	604.18	604.22
B	49+09.91	-11.00	604.30	604.37
C	49+19.91	-11.00	604.40	604.50
D	49+29.91	-11.00	604.50	604.60
E	49+39.91	-11.00	604.58	604.69
F	49+49.91	-11.00	604.65	604.75
G	49+59.91	-11.00	604.72	604.79
H	49+69.91	-11.00	604.77	604.82
I	49+79.91	-11.00	604.82	604.85
J	49+89.91	-11.00	604.85	604.87
C Bearing Pier	50+02.75	-11.00	604.88	604.88
K	50+12.75	-11.00	604.89	604.91
L	50+22.75	-11.00	604.89	604.94
M	50+32.75	-11.00	604.88	604.96
N	50+42.75	-11.00	604.86	604.97
O	50+52.75	-11.00	604.83	604.98
P	50+62.75	-11.00	604.79	604.97
Q	50+72.75	-11.00	604.74	604.91
R	50+82.75	-11.00	604.69	604.84
S	50+92.75	-11.00	604.62	604.76
T	51+02.75	-11.00	604.54	604.63
U	51+12.75	-11.00	604.45	604.50
C Bearing E. Abut.	51+21.97	-11.00	604.36	604.36
Bk. of E. Abutment	51+23.25	-11.00	604.34	604.34

Girder 5

Location	Station	Offset from C.F.A.P. 95	Theoretical Grade Elevations	Theoretical Grade Elevations Adjusted For Dead Load Deflection
Bk. of W. Abutment	48+87.91	-7.80	604.08	604.08
C Bearing W. Abut.	48+89.19	-7.80	604.10	604.10
A	48+99.19	-7.80	604.23	604.26
B	49+09.19	-7.80	604.34	604.41
C	49+19.19	-7.80	604.44	604.55
D	49+29.19	-7.80	604.54	604.64
E	49+39.19	-7.80	604.62	604.73
F	49+49.19	-7.80	604.70	604.80
G	49+59.19	-7.80	604.76	604.84
H	49+69.19	-7.80	604.82	604.87
I	49+79.19	-7.80	604.86	604.90
J	49+89.19	-7.80	604.90	604.92
C Bearing Pier	50+02.03	-7.80	604.93	604.93
K	50+12.03	-7.80	604.94	604.96
L	50+22.03	-7.80	604.94	604.99
M	50+32.03	-7.80	604.93	605.01
N	50+42.03	-7.80	604.91	605.02
O	50+52.03	-7.80	604.89	605.03
P	50+62.03	-7.80	604.85	605.02
Q	50+72.03	-7.80	604.80	604.96
R	50+82.03	-7.80	604.74	604.90
S	50+92.03	-7.80	604.67	604.82
T	51+02.03	-7.80	604.59	604.69
U	51+12.03	-7.80	604.51	604.55
C Bearing E. Abut.	51+21.25	-7.80	604.42	604.42
Bk. of E. Abutment	51+22.53	-7.80	604.40	604.40

DESIGNED	A.C.S.
CHECKED	B.B.
DRAWN	W.J.S.
CHECKED	C.J.F.

TOP OF SLAB ELEVATIONS
STRUCTURE NO. 025-0106



BERNARDIN
LOCHMUELLER &
ASSOCIATES, INC.

3 Oak Drive
Mayville, IL 62422-5835
Local (618) 288-4865
Fax 618-288-4866

SHEET NO. 8 38 SHEETS	F.A.I. RTE.	SECTION	COUNTY	TOTAL SHEETS	SHEET NO.
	57/70	(25-3HB-2)B	EFFINGHAM	839	337
SN 025-0106			CONTRACT NO. 74293		
FED. ROAD DIST. NO. 7 ILLINOIS FED. AID PROJECT					

STATE OF ILLINOIS
DEPARTMENT OF TRANSPORTATION

☉ Roadway (F.A.P. 95)

Location	Station	Offset from ☉ F.A.P. 95	Theoretical Grade Elevations	Theoretical Grade Elevations Adjusted For Dead Load Deflection
Bk. of W. Abutment	48+86.16	0.00	604.18	604.18
☉ Bearing W. Abut.	48+87.45	0.00	604.20	604.20
A	48+97.45	0.00	604.33	604.36
B	49+07.45	0.00	604.44	604.51
C	49+17.45	0.00	604.55	604.65
D	49+27.45	0.00	604.65	604.75
E	49+37.45	0.00	604.73	604.84
F	49+47.45	0.00	604.81	604.91
G	49+57.45	0.00	604.87	604.95
H	49+67.45	0.00	604.93	604.98
I	49+77.45	0.00	604.98	605.01
J	49+87.45	0.00	605.01	605.03
☉ Bearing Pier	50+00.29	0.00	605.05	605.05
K	50+10.29	0.00	605.06	605.09
L	50+20.29	0.00	605.06	605.11
M	50+30.29	0.00	605.06	605.13
N	50+40.29	0.00	605.04	605.15
O	50+50.29	0.00	605.01	605.16
P	50+60.29	0.00	604.98	605.15
Q	50+70.29	0.00	604.93	605.10
R	50+80.29	0.00	604.87	605.03
S	50+90.29	0.00	604.81	604.95
T	51+00.29	0.00	604.73	604.83
U	51+10.29	0.00	604.64	604.69
☉ Bearing E. Abut.	51+19.51	0.00	604.55	604.55
Bk. of E. Abutment	51+20.79	0.00	604.54	604.54

Girder 6

Location	Station	Offset from ☉ F.A.P. 95	Theoretical Grade Elevations	Theoretical Grade Elevations Adjusted For Dead Load Deflection
Bk. of W. Abutment	48+85.99	0.79	604.17	604.17
☉ Bearing W. Abut.	48+87.27	0.79	604.19	604.19
A	48+97.27	0.79	604.31	604.35
B	49+07.27	0.79	604.43	604.50
C	49+17.27	0.79	604.54	604.64
D	49+27.27	0.79	604.63	604.74
E	49+37.27	0.79	604.72	604.83
F	49+47.27	0.79	604.79	604.90
G	49+57.27	0.79	604.86	604.94
H	49+67.27	0.79	604.92	604.97
I	49+77.27	0.79	604.96	605.00
J	49+87.27	0.79	605.00	605.02
☉ Bearing Pier	50+00.11	0.79	605.03	605.03
K	50+10.11	0.79	605.05	605.07
L	50+20.11	0.79	605.05	605.10
M	50+30.11	0.79	605.04	605.12
N	50+40.11	0.79	605.03	605.14
O	50+50.11	0.79	605.00	605.14
P	50+60.11	0.79	604.96	605.14
Q	50+70.11	0.79	604.92	605.08
R	50+80.11	0.79	604.86	605.02
S	50+90.11	0.79	604.80	604.94
T	51+00.11	0.79	604.72	604.82
U	51+10.11	0.79	604.63	604.68
☉ Bearing E. Abut.	51+19.33	0.79	604.54	604.54
Bk. of E. Abutment	51+20.61	0.79	604.53	604.53

Stage II Construction Joint

Location	Station	Offset from ☉ F.A.P. 95	Theoretical Grade Elevations	Theoretical Grade Elevations Adjusted For Dead Load Deflection
Bk. of W. Abutment	48+85.35	3.67	604.12	604.12
☉ Bearing W. Abut.	48+86.63	3.67	604.13	604.13
A	48+96.63	3.67	604.26	604.30
B	49+06.63	3.67	304.38	604.45
C	49+16.63	3.67	604.48	604.59
D	49+26.63	3.67	604.58	604.69
E	49+36.63	3.67	604.67	604.78
F	49+46.63	3.67	604.74	604.85
G	49+56.63	3.67	604.81	604.89
H	49+66.63	3.67	604.87	604.92
I	49+76.63	3.67	604.92	604.95
J	49+86.63	3.67	604.95	604.97
☉ Bearing Pier	49+99.47	3.67	604.99	604.99
K	50+09.47	3.67	605.00	605.03
L	50+19.47	3.67	605.01	605.06
M	50+29.47	3.67	605.00	605.08
N	50+39.47	3.67	604.98	605.09
O	50+49.47	3.67	604.96	605.10
P	50+59.47	3.67	604.92	605.10
Q	50+69.47	3.67	604.88	605.04
R	50+79.47	3.67	604.82	604.98
S	50+89.47	3.67	604.76	604.90
T	50+99.47	3.67	604.68	604.78
U	51+09.47	3.67	604.59	604.64
☉ Bearing E. Abut.	51+18.69	3.67	604.51	604.51
Bk. of E. Abutment	51+19.97	3.67	604.49	604.49

DESIGNED	A.C.S.
CHECKED	B.B.
DRAWN	W.J.S.
CHECKED	C.J.F.

TOP OF SLAB ELEVATIONS
STRUCTURE NO. 025-0106



**BERNARDIN
LOCHMUELLER &
ASSOCIATES, INC.**

8 Oak Drive
Maryville, IL 62952-2655
Local (618) 288-4665
Fax 618-288-4666

SHEET NO. 9 38 SHEETS	F.A.I. RTE.	SECTION	COUNTY	TOTAL SHEETS	SHEET NO.
	57/70	(25-3HB-2)B	EFFINGHAM	839	338
SN 025-0106			CONTRACT NO. 74293		
FED. ROAD DIST. NO. 7 ILLINOIS FED. AID PROJECT					

STATE OF ILLINOIS
DEPARTMENT OF TRANSPORTATION

Stage I Construction Joint

Location	Station	Offset from \odot F.A.P. 95	Theoretical Grade Elevations	Theoretical Grade Elevations Adjusted For Dead Load Deflection
Bk. of W. Abutment	48+84.75	6.33	604.07	604.07
\odot Bearing W. Abut.	48+86.03	6.33	604.08	604.08
A	48+96.03	6.33	604.21	604.25
B	49+06.03	6.33	604.33	604.40
C	49+16.03	6.33	604.44	604.54
D	49+26.03	6.33	604.53	604.64
E	49+36.03	6.33	604.62	604.73
F	49+46.03	6.33	604.70	604.80
G	49+56.03	6.33	604.77	604.84
H	49+66.03	6.33	604.82	604.88
I	49+76.03	6.33	604.87	604.90
J	49+86.03	6.33	604.91	604.93
\odot Bearing Pier	49+98.87	6.33	604.94	604.94
K	50+08.87	6.33	604.96	604.98
L	50+18.87	6.33	604.96	605.02
M	50+28.87	6.33	604.96	605.04
N	50+38.87	6.33	604.94	605.05
O	50+48.87	6.33	604.92	605.06
P	50+58.87	6.33	604.88	605.06
Q	50+68.87	6.33	604.84	605.00
R	50+78.87	6.33	604.78	604.94
S	50+88.87	6.33	604.72	604.86
T	50+98.87	6.33	604.64	604.74
U	51+08.87	6.33	604.56	604.60
\odot Bearing E. Abut.	51+18.09	6.33	604.47	604.47
Bk. of E. Abutment	51+19.37	6.33	604.46	604.46

Girder 7

Location	Station	Offset from \odot F.A.P. 95	Theoretical Grade Elevations	Theoretical Grade Elevations Adjusted For Dead Load Deflection
Bk. of W. Abutment	48+84.07	9.37	604.01	604.01
\odot Bearing W. Abut.	48+85.35	9.37	604.03	604.03
A	48+95.35	9.37	604.15	604.19
B	49+05.35	9.37	604.27	604.34
C	49+15.35	9.37	604.38	604.48
D	49+25.35	9.37	604.48	604.58
E	49+35.35	9.37	604.57	604.68
F	49+45.35	9.37	604.65	604.75
G	49+55.35	9.37	604.71	604.79
H	49+65.35	9.37	604.77	604.83
I	49+75.35	9.37	604.82	604.85
J	49+85.35	9.37	604.86	604.88
\odot Bearing Pier	49+98.19	9.37	604.89	604.89
K	50+08.19	9.37	604.91	604.94
L	50+18.19	9.37	604.92	604.97
M	50+28.19	9.37	604.91	604.99
N	50+38.19	9.37	604.90	605.01
O	50+48.19	9.37	604.87	605.02
P	50+58.19	9.37	604.84	605.01
Q	50+68.19	9.37	604.79	604.96
R	50+78.19	9.37	604.74	604.90
S	50+88.19	9.37	604.67	604.82
T	50+98.19	9.37	604.60	604.70
U	51+08.19	9.37	604.52	604.56
\odot Bearing E. Abut.	51+17.41	9.37	604.43	604.43
Bk. of E. Abutment	51+18.69	9.37	604.42	604.42

Profile Grade (E.B.)

Location	Station	Offset from \odot F.A.P. 95	Theoretical Grade Elevations	Theoretical Grade Elevations Adjusted For Dead Load Deflection
Bk. of W. Abutment	48+83.71	11.00	603.98	603.98
\odot Bearing W. Abut.	48+84.99	11.00	604.00	604.00
A	48+94.99	11.00	604.12	604.16
B	49+04.99	11.00	604.24	604.32
C	49+14.99	11.00	604.35	604.45
D	49+24.99	11.00	604.45	604.56
E	49+34.99	11.00	604.54	604.65
F	49+44.99	11.00	604.62	604.72
G	49+54.99	11.00	604.69	604.76
H	49+64.99	11.00	604.75	604.80
I	49+74.99	11.00	604.79	604.83
J	49+84.99	11.00	604.83	604.85
\odot Bearing Pier	49+97.83	11.00	604.87	604.87
K	50+07.83	11.00	604.88	604.91
L	50+17.83	11.00	604.89	604.94
M	50+27.83	11.00	604.89	604.97
N	50+37.83	11.00	604.87	604.98
O	50+47.83	11.00	604.85	604.99
P	50+57.83	11.00	604.81	604.99
Q	50+67.83	11.00	604.77	604.94
R	50+77.83	11.00	604.72	604.87
S	50+87.83	11.00	604.65	604.80
T	50+97.83	11.00	604.58	604.67
U	51+07.83	11.00	604.49	604.54
\odot Bearing E. Abut.	51+17.05	11.00	604.41	604.41
Bk. of E. Abutment	51+18.33	11.00	604.39	604.39

DESIGNED	A.C.S.
CHECKED	B.B.
DRAWN	W.J.S.
CHECKED	C.J.F.

TOP OF SLAB ELEVATIONS
STRUCTURE NO. 025-0106



BERNARDIN
LOCHMUELLER &
ASSOCIATES, INC.

3 Oak Drive
Macyville, IL 62462-5635
Local (618) 398-4665
Fax 618-398-4666

SHEET NO. 10 38 SHEETS	F.A.I. RTE.	SECTION	COUNTY	TOTAL SHEETS	SHEET NO.
	57/70	(25-3HB-2)B	EFFINGHAM	839	339
SN 025-0106			CONTRACT NO. 74293		
FED. ROAD DIST. NO. 7 ILLINOIS FED. AID PROJECT					

STATE OF ILLINOIS
DEPARTMENT OF TRANSPORTATION

Girder 8

Location	Station	Offset from $\text{\textcircled{C}}$ F.A.P. 95	Theoretical Grade Elevations	Theoretical Grade Elevations Adjusted For Dead Load Deflection
Bk. of W. Abutment	48+82.15	17.95	603.81	603.81
$\text{\textcircled{C}}$ Bearing W. Abut.	48+83.43	17.95	603.83	603.83
A	48+93.43	17.95	603.96	604.00
B	49+03.43	17.95	604.08	604.15
C	49+13.43	17.95	604.19	604.29
D	49+23.43	17.95	604.29	604.40
E	49+33.43	17.95	604.38	604.49
F	49+43.43	17.95	604.46	604.56
G	49+53.43	17.95	604.53	604.61
H	49+63.43	17.95	604.59	604.64
I	49+73.43	17.95	604.64	604.68
J	49+83.43	17.95	604.68	604.70
$\text{\textcircled{C}}$ Bearing Pier	49+96.27	17.95	604.72	604.72
K	50+06.27	17.95	604.74	604.76
L	50+16.27	17.95	604.75	604.80
M	50+26.27	17.95	604.74	604.82
N	50+36.27	17.95	604.73	604.84
O	50+46.27	17.95	604.71	604.85
P	50+56.27	17.95	604.68	604.85
Q	50+66.27	17.95	604.63	604.80
R	50+76.27	17.95	604.58	604.74
S	50+86.27	17.95	604.52	604.66
T	50+96.27	17.95	604.45	604.54
U	51+06.27	17.95	604.36	604.41
$\text{\textcircled{C}}$ Bearing E. Abut.	51+15.49	17.95	604.28	604.28
Bk. of E. Abutment	51+16.77	17.95	604.27	604.27

Girder 9

Location	Station	Offset from $\text{\textcircled{C}}$ F.A.P. 95	Theoretical Grade Elevations	Theoretical Grade Elevations Adjusted For Dead Load Deflection
Bk. of W. Abutment	48+80.23	26.53	603.61	603.61
$\text{\textcircled{C}}$ Bearing W. Abut.	48+81.51	26.53	603.62	603.62
A	48+91.51	26.53	603.76	603.79
B	49+01.51	26.53	603.88	603.95
C	49+11.51	26.53	603.99	604.09
D	49+21.51	26.53	604.09	604.20
E	49+31.51	26.53	604.19	604.29
F	49+41.51	26.53	604.27	604.37
G	49+51.51	26.53	604.34	604.42
H	49+61.51	26.53	604.40	604.45
I	49+71.51	26.53	604.46	604.49
J	49+81.51	26.53	604.50	604.52
$\text{\textcircled{C}}$ Bearing Pier	49+94.36	26.53	604.54	604.54
K	50+04.36	26.53	604.56	604.58
L	50+14.36	26.53	604.57	604.62
M	50+24.36	26.53	604.57	604.64
N	50+34.36	26.53	604.55	604.67
O	50+44.36	26.53	604.53	604.68
P	50+54.36	26.53	604.50	604.68
Q	50+64.36	26.53	604.46	604.63
R	50+74.36	26.53	604.41	604.57
S	50+84.36	26.53	604.35	604.50
T	50+94.36	26.53	604.28	604.38
U	51+04.36	26.53	604.20	604.25
$\text{\textcircled{C}}$ Bearing E. Abut.	51+13.57	26.53	604.12	604.12
Bk. of E. Abutment	51+14.86	26.53	604.10	604.10

Girder 10

Location	Station	Offset from $\text{\textcircled{C}}$ F.A.P. 95	Theoretical Grade Elevations	Theoretical Grade Elevations Adjusted For Dead Load Deflection
Bk. of W. Abutment	48+78.31	35.12	603.40	603.40
$\text{\textcircled{C}}$ Bearing W. Abut.	48+79.59	35.12	603.42	603.42
A	48+89.59	35.12	603.55	603.59
B	48+99.59	35.12	603.68	603.75
C	49+09.59	35.12	603.79	603.89
D	49+19.59	35.12	603.90	604.00
E	49+29.59	35.12	603.99	604.10
F	49+39.59	35.12	604.07	604.18
G	49+49.59	35.12	604.15	604.23
H	49+59.59	35.12	604.21	604.26
I	49+69.59	35.12	604.27	604.30
J	49+79.59	35.12	604.31	604.33
$\text{\textcircled{C}}$ Bearing Pier	49+92.44	35.12	604.35	604.35
K	50+02.44	35.12	604.37	604.40
L	50+12.44	35.12	604.39	604.44
M	50+22.44	35.12	604.39	604.47
N	50+32.44	35.12	604.38	604.49
O	50+42.44	35.12	604.36	604.50
P	50+52.44	35.12	604.33	604.50
Q	50+62.44	35.12	604.29	604.46
R	50+72.44	35.12	604.24	604.40
S	50+82.44	35.12	604.19	604.33
T	50+92.44	35.12	604.12	604.21
U	51+02.44	35.12	604.04	604.08
$\text{\textcircled{C}}$ Bearing E. Abut.	51+11.66	35.12	603.96	603.96
Bk. of E. Abutment	51+12.94	35.12	603.94	603.94

DESIGNED	A.C.S.
CHECKED	B.B.
DRAWN	W.J.S.
CHECKED	C.J.F.

TOP OF SLAB ELEVATIONS
STRUCTURE NO. 025-0106



**BERNARDIN
LOCHMUELLER &
ASSOCIATES, INC.**

3 Oak Drive
Merriville, IL 62962-5635
Local (618) 288-4665
Fax 618-288-4666

SHEET NO. 11 38 SHEETS	F.A.I. RTE.	SECTION	COUNTY	TOTAL SHEETS	SHEET NO.
	57/70	(25-3HB-2)B	EFFINGHAM	839	340
SN 025-0106			CONTRACT NO. 74293		
FED. ROAD DIST. NO. 7 ILLINOIS FED. AID PROJECT					

STATE OF ILLINOIS
DEPARTMENT OF TRANSPORTATION

EDGE OF SIDEWALK

Location	Station	Offset from C.F.A.P. 95	Theoretical Grade Elevations
End of West Approach	48+66.13	-44.58	603.39
A	48+76.13	-44.58	603.54
B	48+86.13	-44.58	603.68
Back of West Abutment	48+96.13	-44.58	603.81

NORTH EDGE OF SHOULDER

Location	Station	Offset from C.F.A.P. 95	Theoretical Grade Elevations
End of West Approach	48+64.43	-37.00	603.16
A	48+74.43	-37.00	603.31
B	48+84.43	-37.00	603.45
Back of West Abutment	48+94.43	-37.00	603.58

NORTH EDGE OF PAVEMENT

Location	Station	Offset from C.F.A.P. 95	Theoretical Grade Elevations
End of West Approach	48+63.99	-35.00	603.19
A	48+73.99	-35.00	603.34
B	48+83.99	-35.00	603.48
Back of West Abutment	48+93.99	-35.00	603.61

PROFILE GRADE (W.B.)

Location	Station	Offset from C.F.A.P. 95	Theoretical Grade Elevations
End of West Approach	48+58.62	-11.00	603.61
A	48+68.62	-11.00	603.76
B	48+78.62	-11.00	603.91
Back of West Abutment	48+88.62	-11.00	604.04

C.F.A.P. 95

Location	Station	Offset from C.F.A.P. 95	Theoretical Grade Elevations
End of West Approach	48+56.16	0.00	603.74
A	48+66.16	0.00	603.90
B	48+76.16	0.00	604.05
Back of West Abutment	48+86.16	0.00	604.18

STAGE I CONST. LINE

Location	Station	Offset from C.F.A.P. 95	Theoretical Grade Elevations
End of West Approach	48+54.74	6.33	603.62
A	48+64.74	6.33	603.78
B	48+74.74	6.33	603.93
Back of West Abutment	48+84.74	6.33	604.07

PROFILE GRADE (E.B.)

Location	Station	Offset from C.F.A.P. 95	Theoretical Grade Elevations
End of West Approach	48+53.71	11.00	603.53
A	48+63.71	11.00	603.69
B	48+73.71	11.00	603.84
Back of West Abutment	48+83.71	11.00	603.98

SOUTH EDGE OF PAVEMENT

Location	Station	Offset from C.F.A.P. 95	Theoretical Grade Elevations
End of West Approach	48+48.33	35.00	602.94
A	48+58.33	35.00	603.10
B	48+68.33	35.00	603.26
Back of West Abutment	48+78.33	35.00	603.40

SOUTH EDGE OF SHOULDER

Location	Station	Offset from C.F.A.P. 95	Theoretical Grade Elevations
End of West Approach	48+47.89	37.00	602.89
A	48+57.89	37.00	603.06
B	48+67.89	37.00	603.21
Back of West Abutment	48+77.89	37.00	603.36

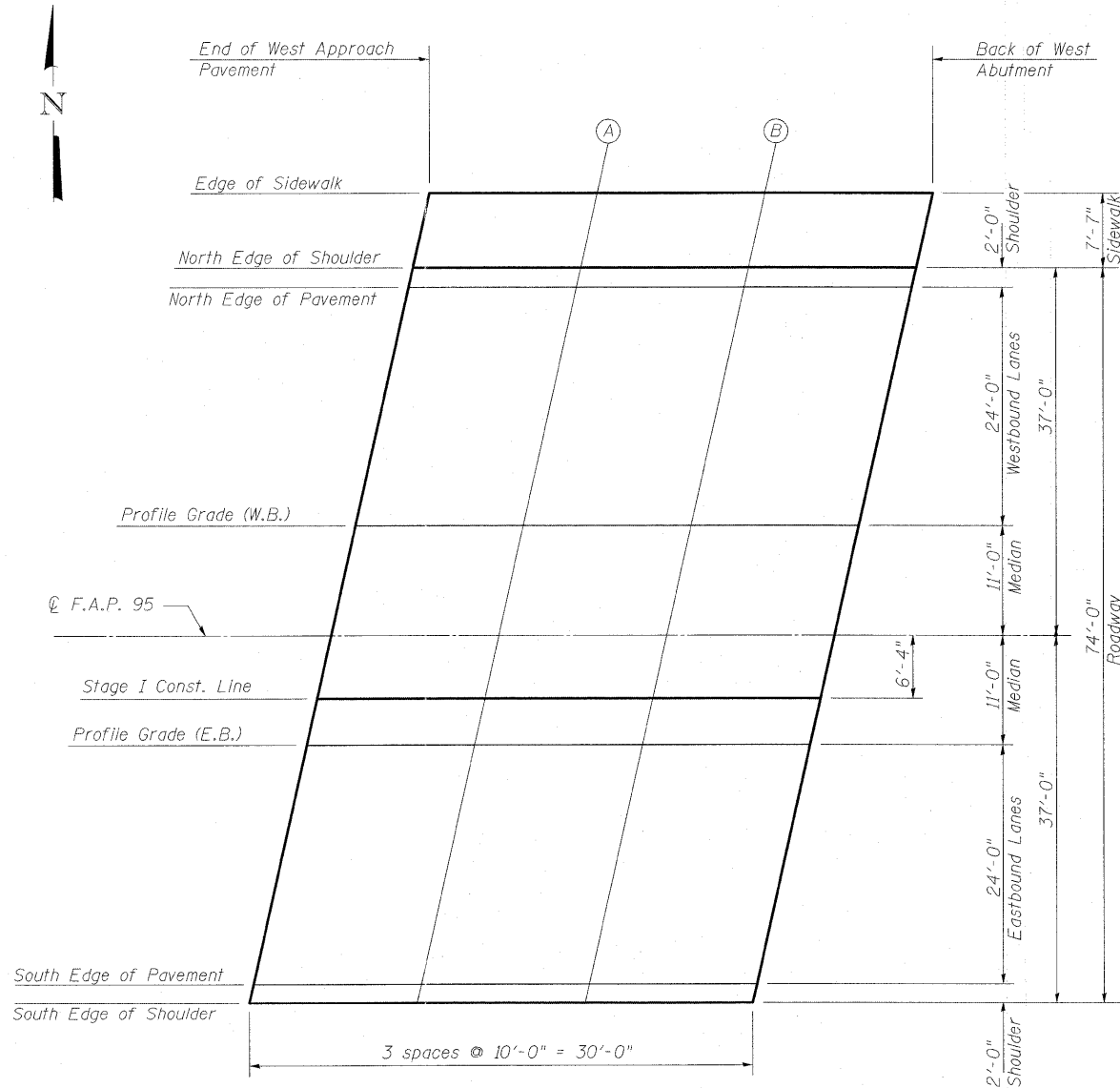

PLAN WEST APPROACH

DESIGNED	A.C.S.
CHECKED	B.B.
DRAWN	W.J.S.
CHECKED	C.J.F.

WEST APPROACH TOP OF SLAB ELEVATIONS
STRUCTURE NO. 025-0106



**BERNARDIN
LOCHMUELLER &
ASSOCIATES, INC.**

3 Oak Drive
Maryville, IL 62442-9655
Local (618) 398-4995
Fax 618-288-4996

SHEET NO. 12	F.A.I. RTE.	SECTION	COUNTY	TOTAL SHEETS	SHEET NO.
	57/70	(25-3HB-2)B	EFFINGHAM	839	341
38 SHEETS	SN 025-0106		CONTRACT NO. 74293		
FED. ROAD DIST. NO. 7 ILLINOIS FED. AID PROJECT					

10/25/05 AM 8/12/2010 10:25:05 AM 10/25/05 AM 8/12/2010

STATE OF ILLINOIS
DEPARTMENT OF TRANSPORTATION

EDGE OF SIDEWALK

Location	Station	Offset from \varnothing F.A.P. 95	Theoretical Grade Elevations
Back of East Abutment	51+30.75	-44.58	603.93
A	51+40.75	-44.58	603.81
B	51+50.75	-44.58	603.69
End of East Approach	51+60.75	-44.58	603.55

NORTH EDGE OF SHOULDER

Location	Station	Offset from \varnothing F.A.P. 95	Theoretical Grade Elevations
Back of East Abutment	51+29.06	-37.00	603.74
A	51+39.06	-37.00	603.63
B	51+49.06	-37.00	603.50
End of East Approach	51+59.06	-37.00	603.36

NORTH EDGE OF PAVEMENT

Location	Station	Offset from \varnothing F.A.P. 95	Theoretical Grade Elevations
Back of East Abutment	51+28.61	-35.00	603.79
A	51+38.61	-35.00	603.67
B	51+48.61	-35.00	603.55
End of East Approach	51+58.61	-35.00	603.41

PROFILE GRADE (W.B.)

Location	Station	Offset from \varnothing F.A.P. 95	Theoretical Grade Elevations
Back of East Abutment	51+23.25	-11.00	604.34
A	51+33.25	-11.00	604.24
B	51+43.25	-11.00	604.12
End of East Approach	51+53.25	-11.00	603.99

\varnothing F.A.P. 95

Location	Station	Offset from \varnothing F.A.P. 95	Theoretical Grade Elevations
Back of East Abutment	51+20.79	0.00	604.54
A	51+30.79	0.00	604.43
B	51+40.79	0.00	604.32
End of East Approach	51+50.79	0.00	604.19

STAGE I CONST. LINE

Location	Station	Offset from \varnothing F.A.P. 95	Theoretical Grade Elevations
Back of East Abutment	51+19.37	6.33	604.46
A	51+29.37	6.33	604.35
B	51+39.37	6.33	604.24
End of East Approach	51+49.37	6.33	604.11

PROFILE GRADE (E.B.)

Location	Station	Offset from \varnothing F.A.P. 95	Theoretical Grade Elevations
Back of East Abutment	51+18.33	11.00	604.39
A	51+28.33	11.00	604.29
B	51+38.33	11.00	604.18
End of East Approach	51+48.33	11.00	604.05

SOUTH EDGE OF PAVEMENT

Location	Station	Offset from \varnothing F.A.P. 95	Theoretical Grade Elevations
Back of East Abutment	51+12.96	35.00	603.95
A	51+22.96	35.00	603.85
B	51+32.96	35.00	603.74
End of East Approach	51+42.96	35.00	603.62

SOUTH EDGE OF SHOULDER

Location	Station	Offset from \varnothing F.A.P. 95	Theoretical Grade Elevations
Back of East Abutment	51+12.51	37.00	603.91
A	51+22.51	37.00	603.81
B	51+32.51	37.00	603.70
End of East Approach	51+42.51	37.00	603.58

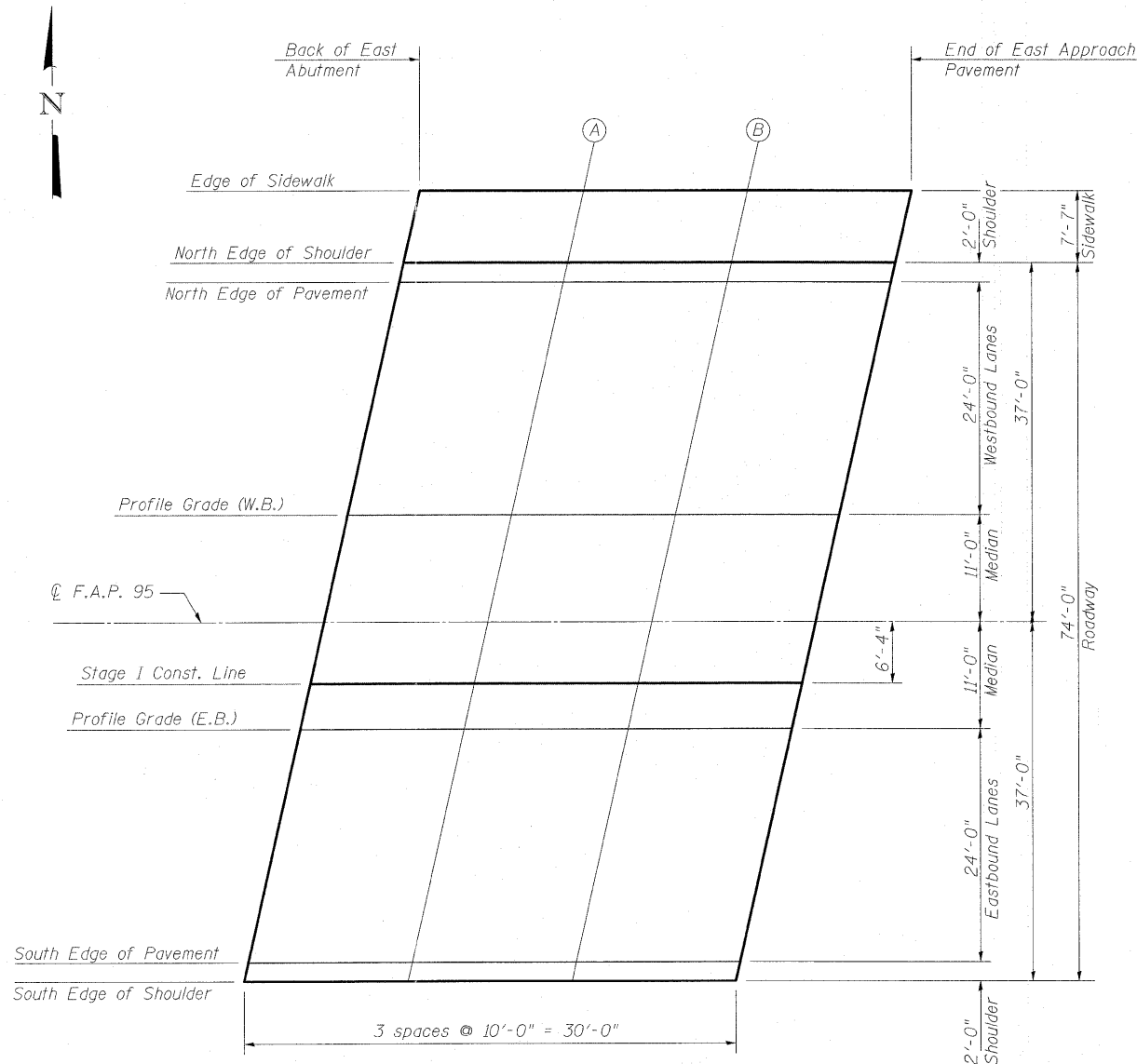

PLAN EAST APPROACH

DESIGNED	A.C.S.
CHECKED	B.B.
DRAWN	W.J.S.
CHECKED	C.J.F.

EAST APPROACH TOP OF SLAB ELEVATIONS
STRUCTURE NO. 025-0106



**BERNARDIN
LOCHMUELLER &
ASSOCIATES, INC.**

3 Oak Drive
Marengo, IL 60428-5685
Local (618) 398-4665
Fax 618-298-4666

SHEET NO. 13 38 SHEETS	F.A.I. RTE.	SECTION	COUNTY	TOTAL SHEETS	SHEET NO.
	57/70	(25-3HB-2)B	EFFINGHAM	839	342
SN 025-0106			CONTRACT NO. 74293		
FED. ROAD DIST. NO. 7 ILLINOIS FED. AID PROJECT					

STATE OF ILLINOIS
DEPARTMENT OF TRANSPORTATION

* Order a(E), a₁(E), a₄(E), a₅(E) and c₁(E) bars full length. Cut to fit skew and use remainder of bars in opposite end.

** Bar Splicers for Stage I and Stage II construction shall be lapped and tied together during Stage III construction.

*** Order c₂(E) bars full length. Cut to fit in median.

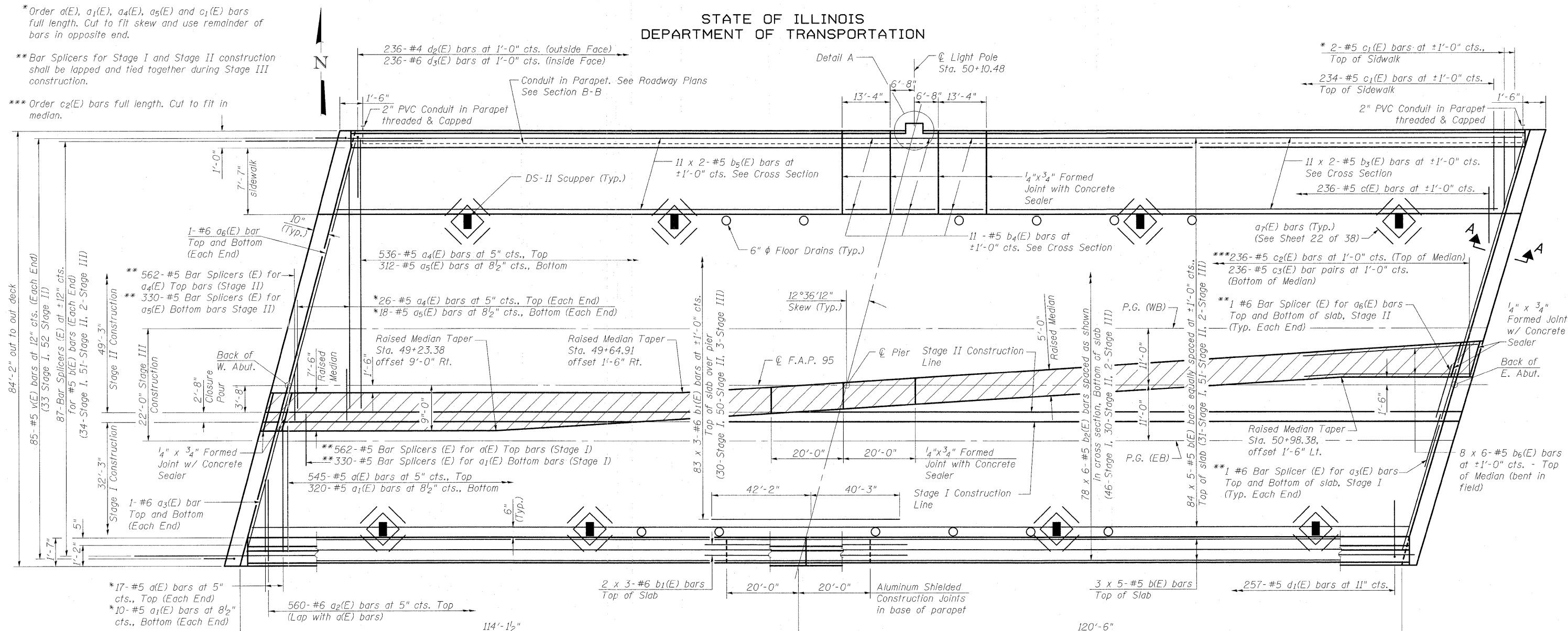

MINIMUM BAR LAP

#5 bar = 2'-6"
#6 bar = 3'-0"

Indicates Superimposed Raised Median
See Sheet 16 of 38 for Raised Median Reinforcement.

Notes:
See Sheet 34 of 38 for Bar Splicer Details.
See Sheet 1 of 38 for drainage scupper and floor drain spacing.
See Sheet 16 of 38 for superstructure details and Bill of Material.
Bars indicated thus 84 x 5-#5 etc. indicates 84 lines of bars with 5 lengths per line.
See Sheets 15 thru 17 of 38 for parapet reinforcement.
For Section A-A and diaphragm details see Sheets 26 and 27 of 38.
See Sheet 20 of 38 for drainage Scupper details.
See Sheet 22 of 38 for floor drain details.
Cut longitudinal reinforcement to clear drainage scuppers.

SUPERSTRUCTURE
STRUCTURE NO. 025-0106

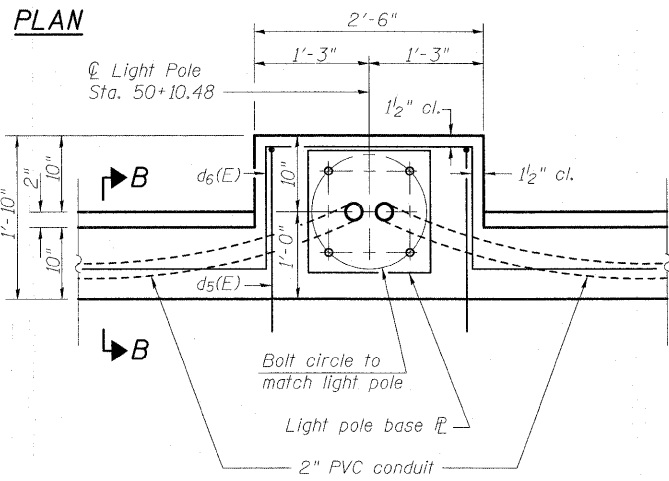

DETAIL A

BERNARDIN
LOCHMUELLER &
ASSOCIATES, INC.
3 Oak Drive
Marengo, IL 62420-5635
Local (618) 398-4955
Fax 618-288-4666

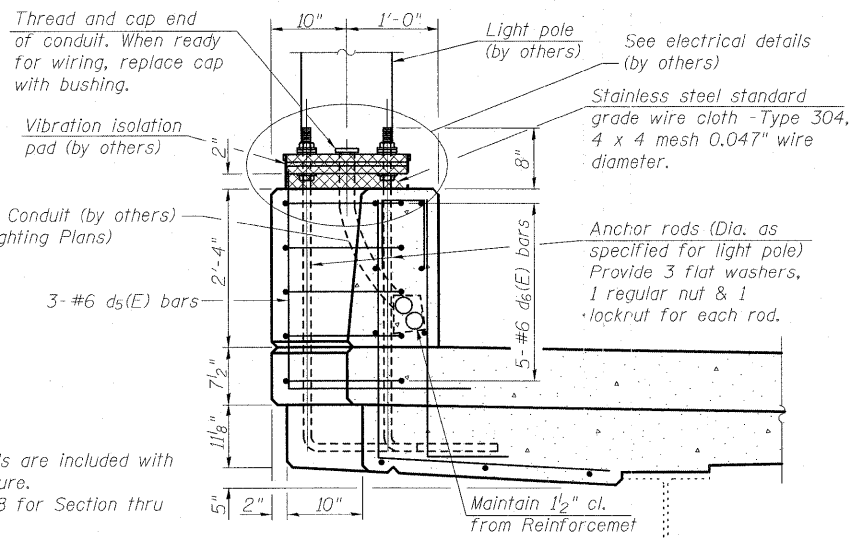

SECTION B-B

(North Light Pedestal)

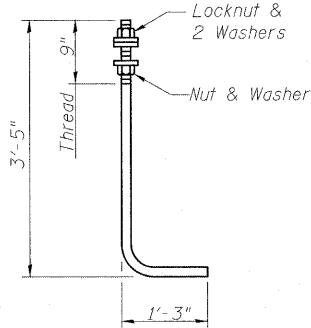

ANCHOR ROD

Diameter as specified for light poles.
(ASTM F 1554 Grade 105)

Notes:
Cost of anchor rods are included with Concrete Superstructure.
See Sheet 16 of 38 for Section thru Parapets.
See Sheet 16 of 38 for Section thru Sidewalk.

DESIGNED	A.C.S.
CHECKED	B.B.
DRAWN	W.J.S.
CHECKED	C.J.F.

SHEET NO. 14 38 SHEETS	F.A.I. RTE.	SECTION	COUNTY	TOTAL SHEETS	SHEET NO.
	57/70	(25-3HB-2)B	EFFINGHAM	839	343
SN 025-0106			CONTRACT NO. 74293		
FED. ROAD DIST. NO. 7 ILLINOIS FED. AID PROJECT					

10/26/05 AM 8/12/2010 10:25:06 for stp14.dgn

STATE OF ILLINOIS
DEPARTMENT OF TRANSPORTATION

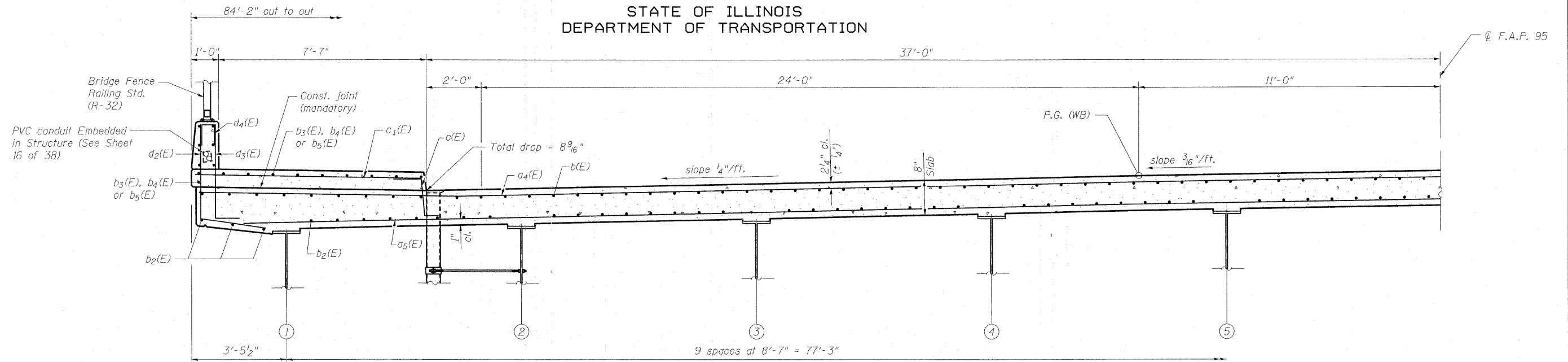

NEAR MIDSPAN

Notes:
Superimposed Median not shown for clarity. See Sheet 16 of 38 for Details.
See Sheet 16 of 38 for Section thru Parpet.
See Sheet 16 of 38 for Section thru Sidewalk.

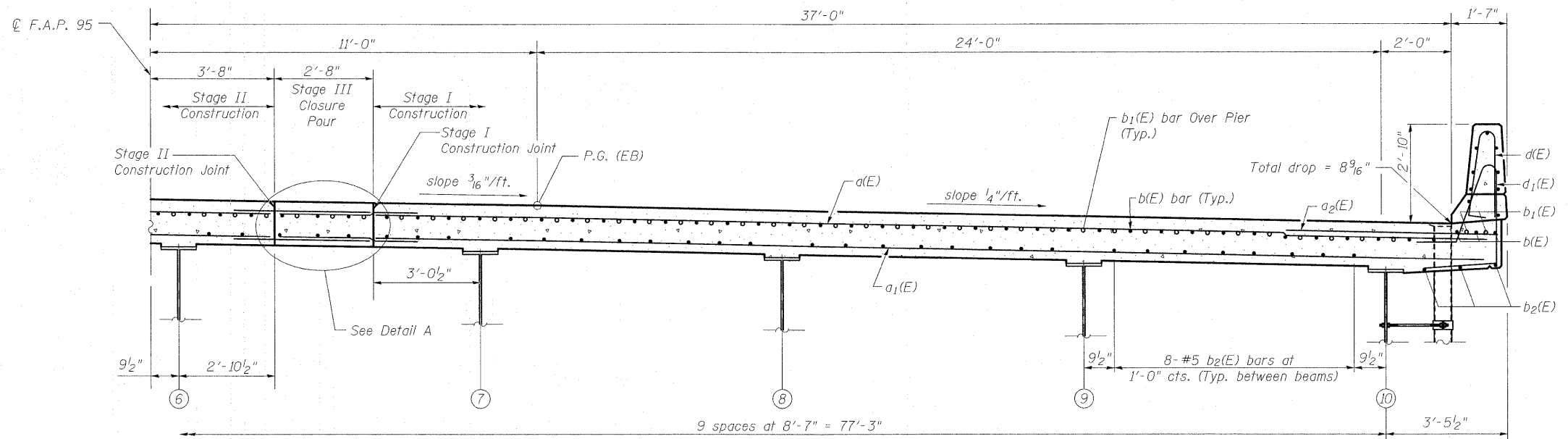

NEAR PIER
CROSS SECTION
(Looking East)

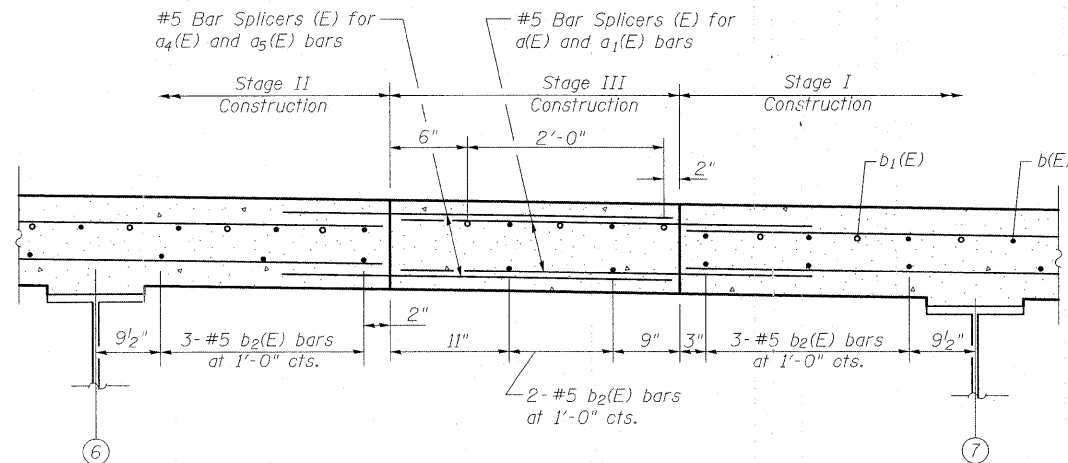

DETAIL A

DESIGNED	A.C.S.
CHECKED	B.B.
DRAWN	W.J.S.
CHECKED	C.J.F.



**BERNARDIN
LOCHMUELLER &
ASSOCIATES, INC.**

3 Oak Drive
Marysville, IL 62452-5655
Local 618-338-4665
Fax 618-288-4666

SHEET NO. 15 38 SHEETS	F.A.I. RTE. 57/70	SECTION (25-3HB-2)B	COUNTY EFFINGHAM	TOTAL SHEETS 839	SHEET NO. 344
	SN 025-0106		CONTRACT NO. 74293		
FED. ROAD DIST. NO. 7 ILLINOIS FED. AID PROJECT					

**SUPERSTRUCTURE
STRUCTURE NO. 025-0106**

STATE OF ILLINOIS
DEPARTMENT OF TRANSPORTATION

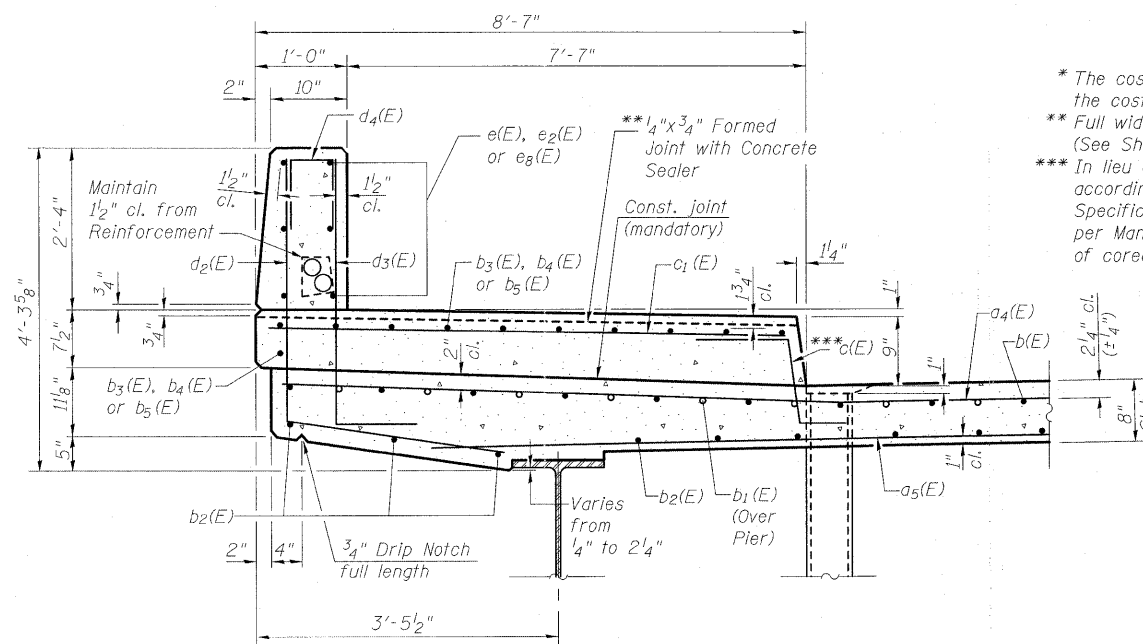

SECTION THRU SIDEWALK

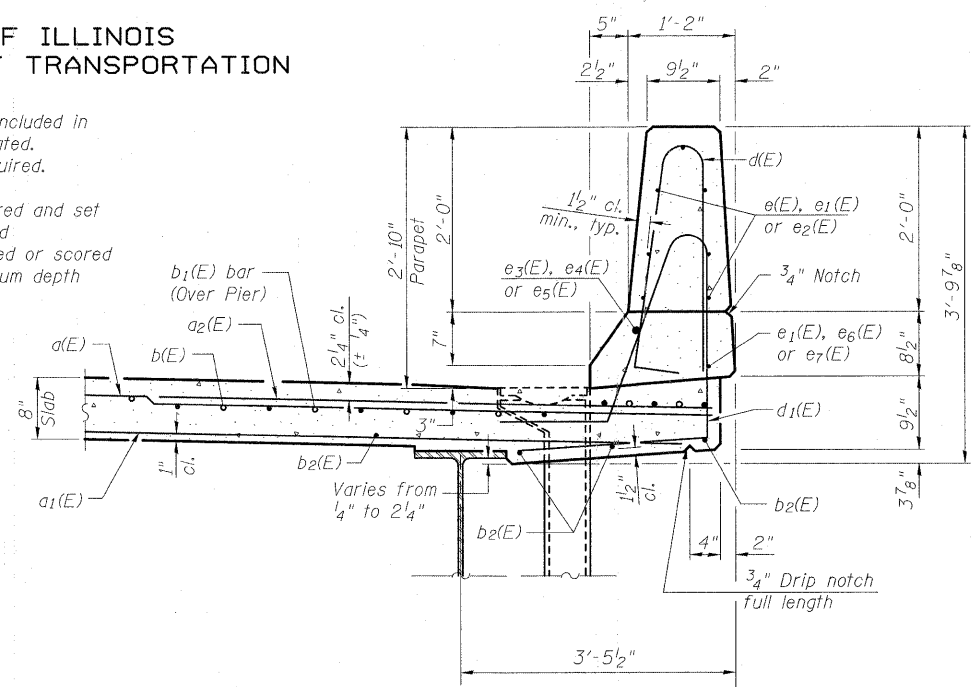

SECTION THRU SOUTH PARAPET

**SUPERSTRUCTURE
BILL OF MATERIAL**

Bar	No.	Size	Length	Shape
a1(E)	562	#5	31'-10"	—
a2(E)	330	#5	31'-2"	—
a3(E)	560	#6	6'-6"	—
a4(E)	4	#6	32'-7"	—
a5(E)	562	#5	48'-10"	—
a6(E)	330	#5	48'-0"	—
a7(E)	4	#6	52'-8"	—
a8(E)	64	#5	1'-6"	—
b1(E)	435	#5	48'-11"	—
b2(E)	255	#6	29'-6"	—
b3(E)	468	#5	41'-2"	—
b4(E)	22	#5	51'-5"	—
b5(E)	33	#5	13'-1"	—
b6(E)	22	#5	49'-2"	—
b7(E)	48	#5	41'-7"	—
c1(E)	236	#5	2'-5"	—
c2(E)	236	#5	8'-2"	—
c3(E)	236	#5	6'-10"	—
c4(E)	472	#5	1'-4"	—
d1(E)	257	#5	5'-7"	—
d2(E)	257	#5	7'-10"	—
d3(E)	236	#4	5'-10"	—
d4(E)	236	#6	4'-6"	—
d5(E)	54	#4	2'-0"	—
d6(E)	3	#6	4'-8"	—
d7(E)	5	#6	8'-11"	—
e1(E)	78	#4	16'-6"	—
e2(E)	16	#4	19'-9"	—
e3(E)	78	#4	15'-5"	—
e4(E)	3	#8	36'-11"	—
e5(E)	2	#8	19'-9"	—
e6(E)	3	#8	34'-9"	—
e7(E)	3	#4	34'-9"	—
e8(E)	3	#4	32'-8"	—
e9(E)	18	#4	13'-1"	—
m1(E)	10	#6	32'-9"	—
m2(E)	40	#6	11'-9"	—
m3(E)	18	#6	8'-5"	—
m4(E)	6	#6	3'-3"	—
m5(E)	10	#6	52'-11"	—
s1(E)	174	#5	6'-11"	—
s2(E)	156	#4	13'-0"	—
v1(E)	170	#5	4'-0"	—
Reinforcement Bars, Epoxy Coated		Pound	158670	
Concrete Superstructure		Cu. Yds.	721.0	
Bar Splicers		Each	1982	

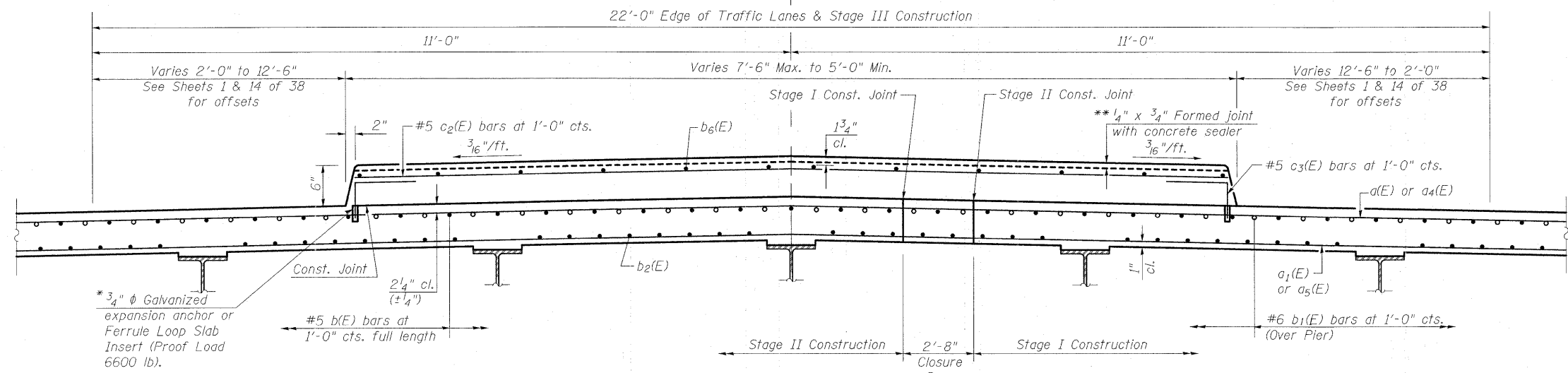

SUPERIMPOSED MEDIAN
(Looking East)

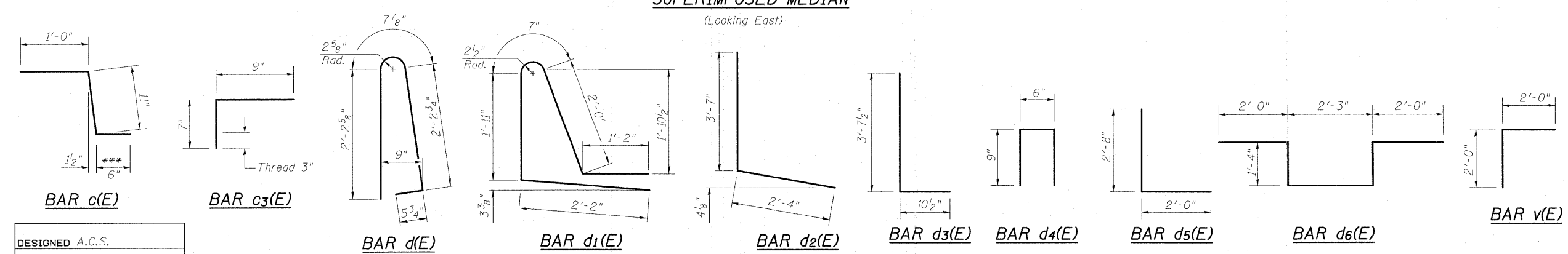

**SUPERSTRUCTURE DETAILS
STRUCTURE NO. 025-0106**

DESIGNED	A.C.S.
CHECKED	B.B.
DRAWN	W.J.S.
CHECKED	C.J.F.

**BERNARDIN
LOCHMUELLER &
ASSOCIATES, INC.**

3 Oak Drive
Maryville, IL 62452-5685
Local (618) 288-4005
Fax 618-288-4666

SHEET NO. 16 38 SHEETS	F.A.I. RTE.	SECTION	COUNTY	TOTAL SHEETS	SHEET NO.
	57/70	(25-3HB-2)B	EFFINGHAM	839	345
SN 025-0106			CONTRACT NO. 74293		
FED. ROAD DIST. NO. 7 ILLINOIS FED. AID PROJECT					

10:26:48 AM 8/12/2010 ...0250106/03-01-16.dgn

STATE OF ILLINOIS
DEPARTMENT OF TRANSPORTATION

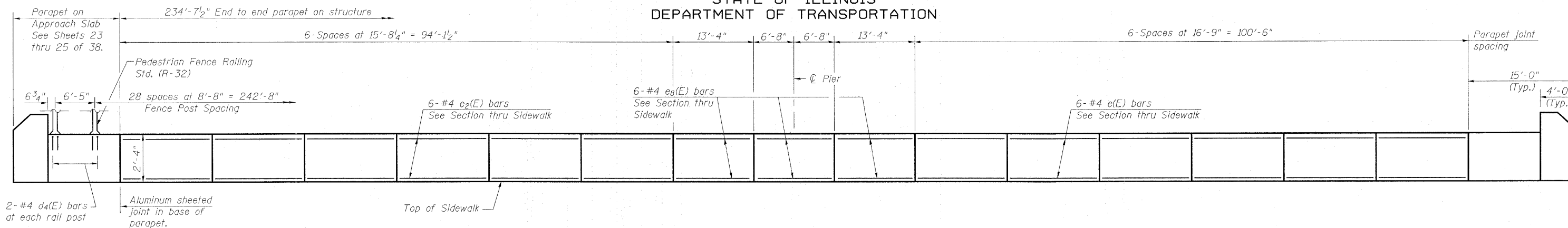

SPAN 1

INSIDE ELEVATION OF PARAPET

(North Parapet Shown)

SPAN 2

MINIMUM BAR LAP

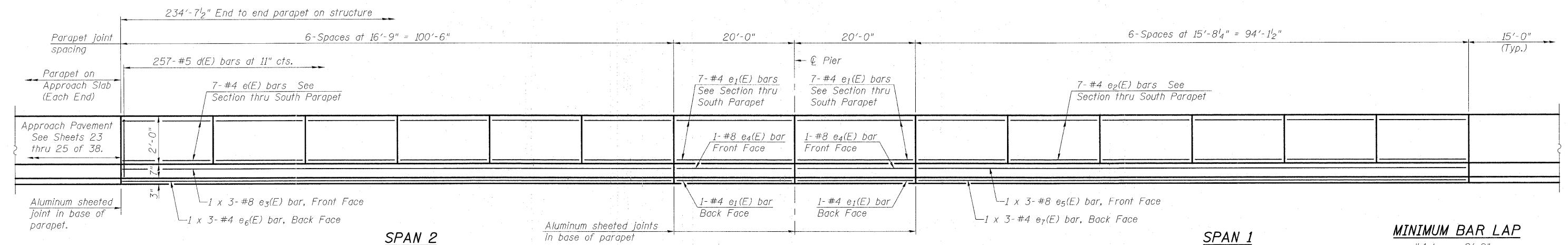

SPAN 2

INSIDE ELEVATION OF PARAPET

(South Parapet Shown)

SPAN 1

MINIMUM BAR LAP

#4 bar = 2'-0"
#8 bar = 5'-2"

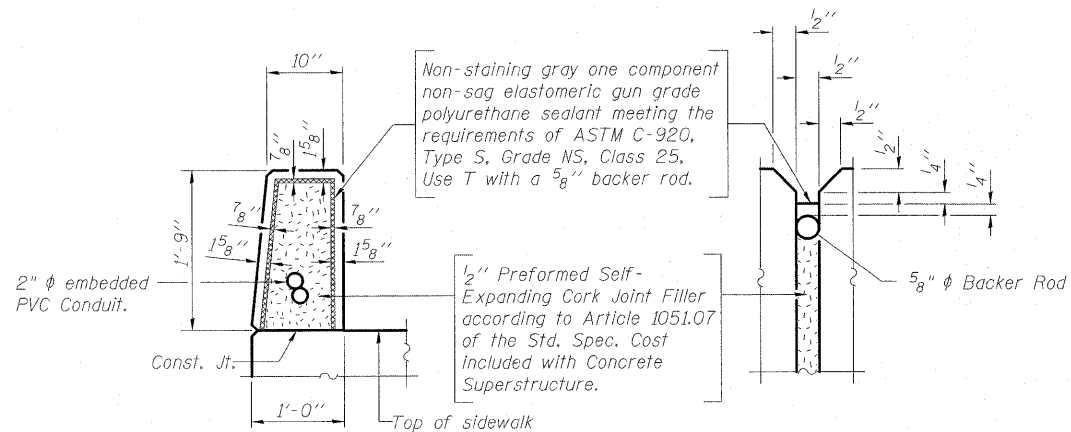

PARAPET JOINT DETAILS

(North Parapet shown)

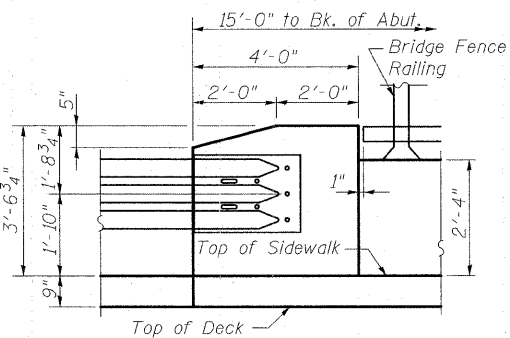

TYPE 6 RAIL ATTACHMENT DETAIL

(shown at sidewalk)

For Reinforcement of Parapet end section see sheet 25 of 38.

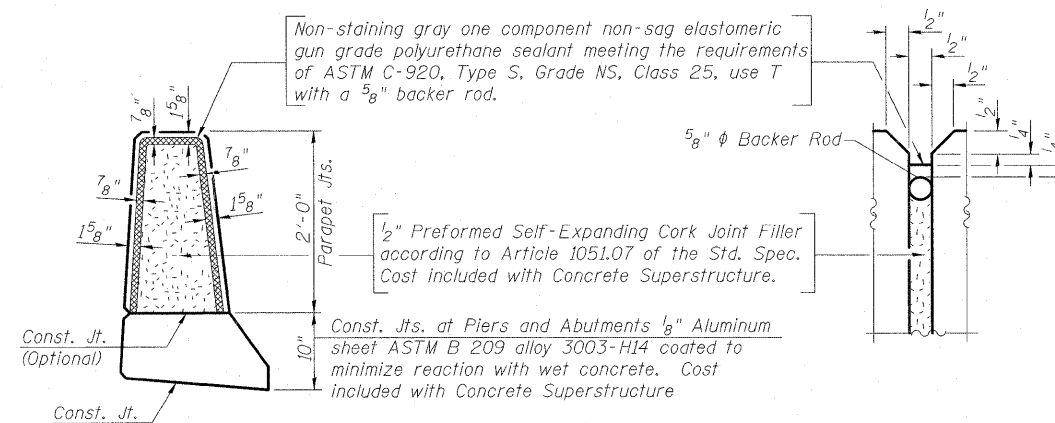

PARAPET JOINT DETAILS

(South Parapet shown)

DESIGNED	A.C.S.
CHECKED	B.B.
DRAWN	W.J.S.
CHECKED	C.J.F.



BERNARDIN
LOCHMUELLER &
ASSOCIATES, INC.

8 Oak Drive
Maryville, IL 62959-5635
Local (618) 288-4655
Fax 618-288-4656

SHEET NO. 17 38 SHEETS	F.A.I. RTE.	SECTION	COUNTY	TOTAL SHEETS	SHEET NO.
	57/70	(25-3HB-2)B	EFFINGHAM	839	346
SN 025-0106			CONTRACT NO. 74293		
FED. ROAD DIST. NO. 7 ILLINOIS FED. AID PROJECT					

SUPERSTRUCTURE DETAILS
STRUCTURE NO. 025-0106

STATE OF ILLINOIS
DEPARTMENT OF TRANSPORTATION

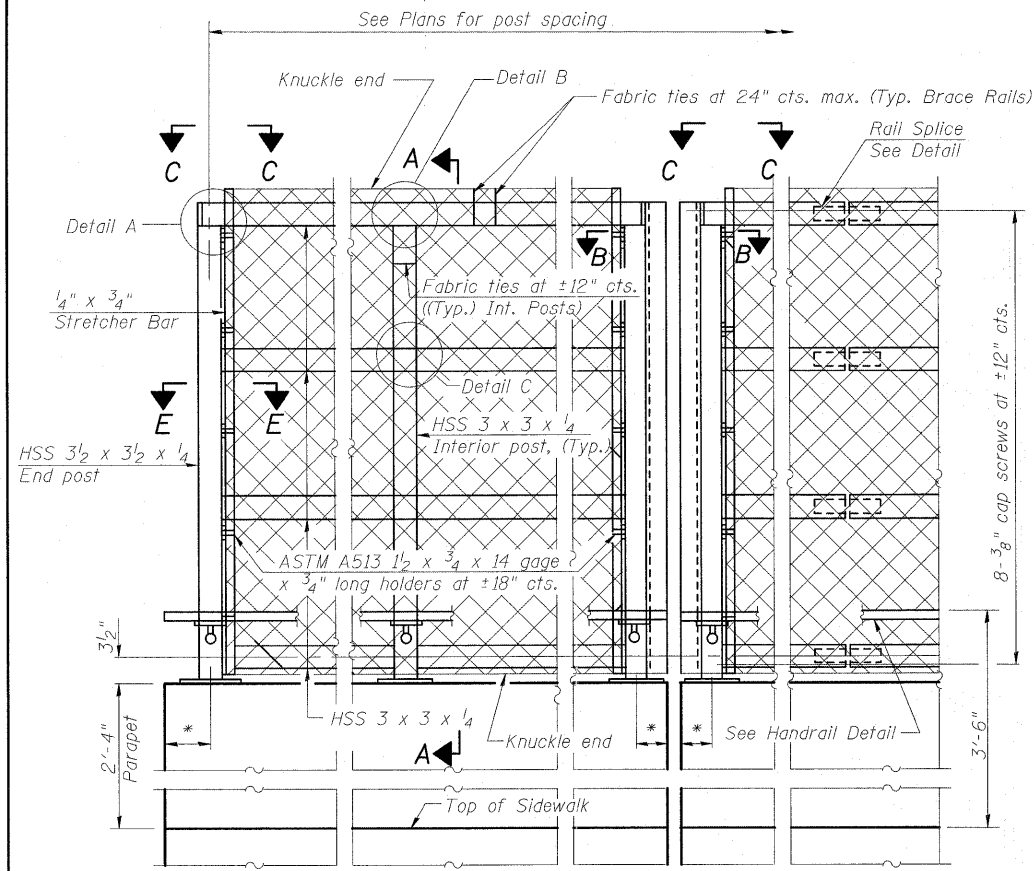

ELEVATION
(Inside Face)

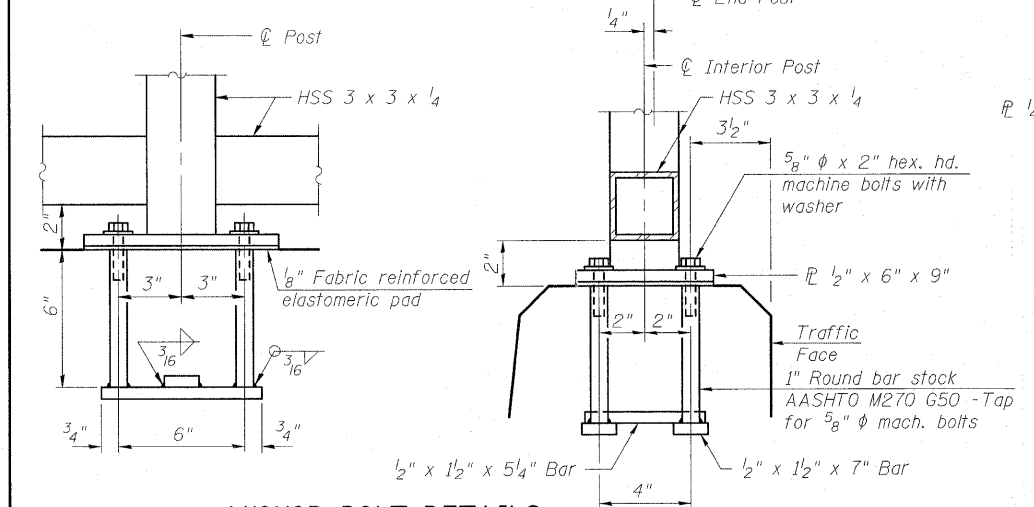

ANCHOR BOLT DETAILS

In lieu of the cast-in-place anchor device shown, the Contractor has the option of drilling and setting 5/8" anchor rods according to Article 509.06 of the Standard Specifications. Embedment shall be according to the manufacturer's specifications.

DESIGNED	
CHECKED	
DRAWN	W.J.S.
CHECKED	C.J.F.

R-32

11-1-09

*Variable - See Plans
(10'-0" Maximum Post Spacing)

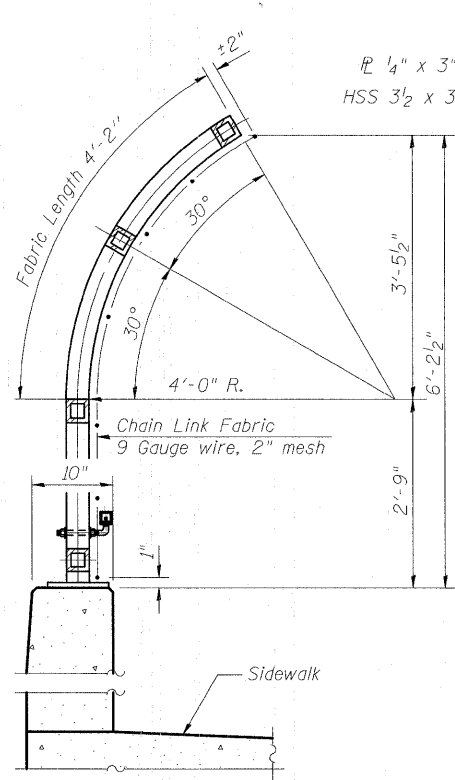

SECTION A-A

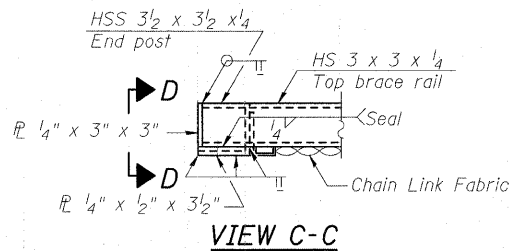

VIEW C-C

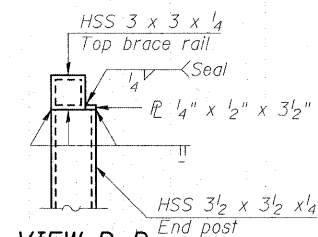

VIEW D-D

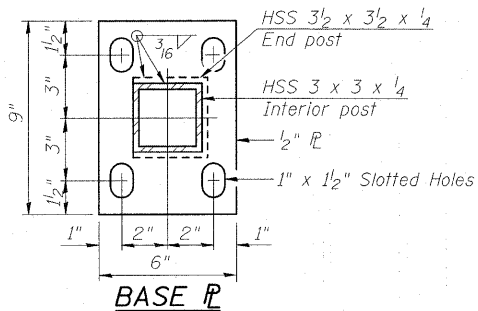

BASE PL

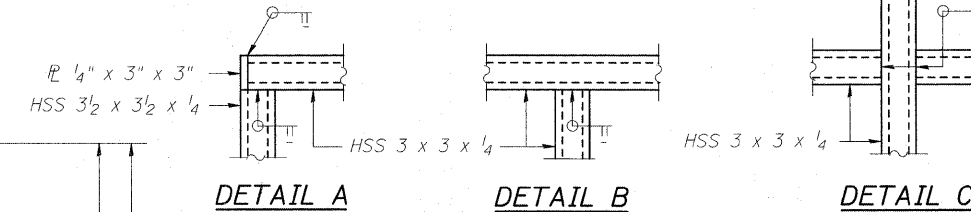

DETAIL A

DETAIL B

DETAIL C

All steel rail elements shall be galvanized according to Article 509.05 of the Standard Specifications.

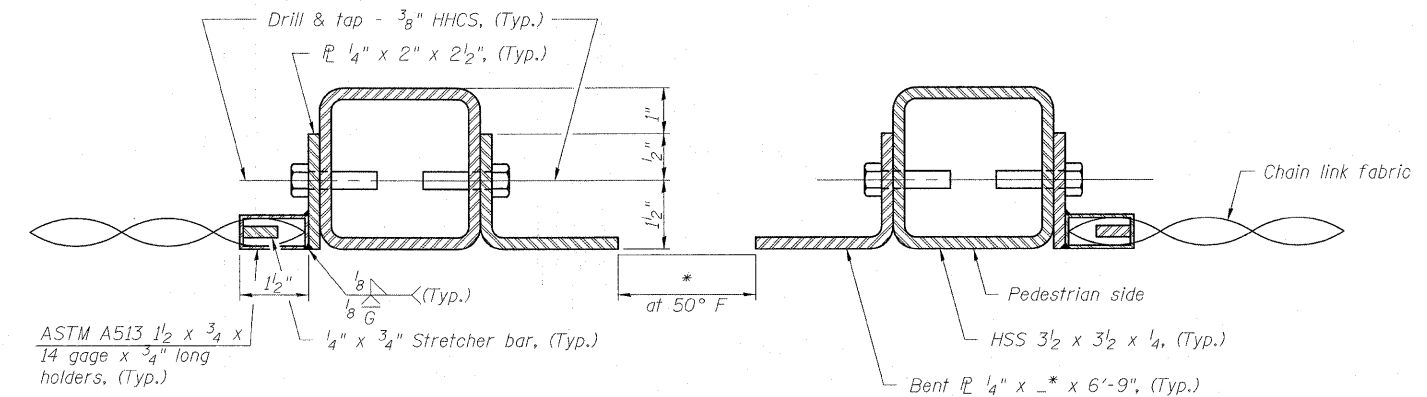

SECTION B-B
(At Expansion Joint)

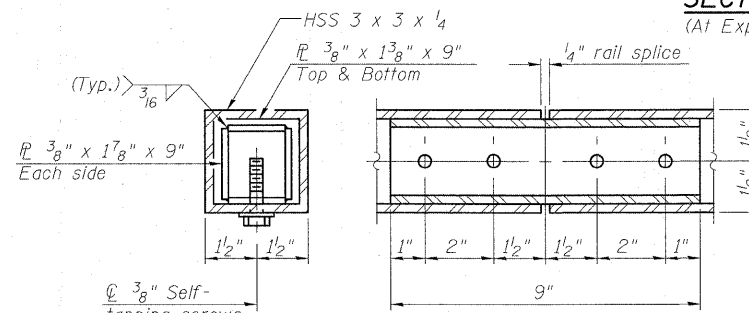

RAIL SPLICE

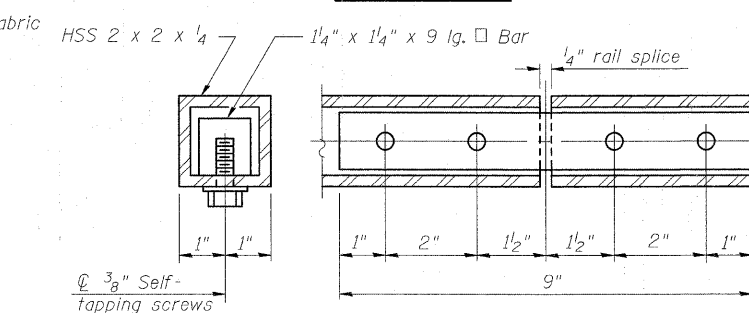

HANDRAIL SPLICE

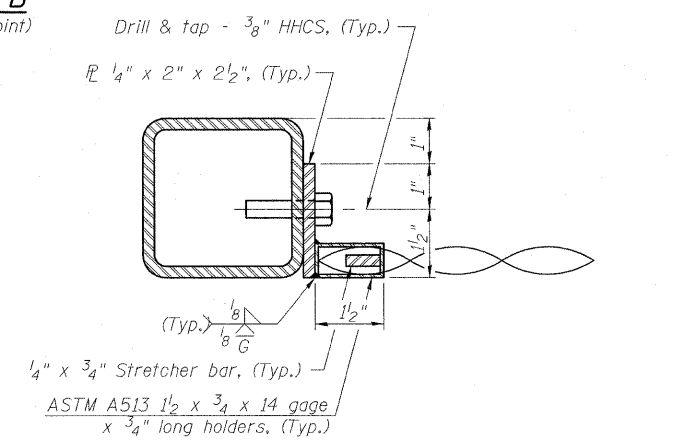

SECTION E-E

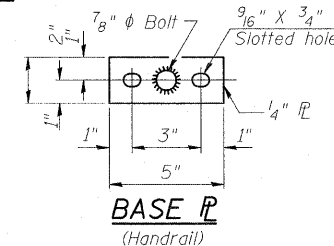

BASE PL
(Handrail)

BILL OF MATERIAL

Item	Unit	Quantity
Bridge Fence Railing	Foot	257

**BRIDGE FENCE RAILING
PARAPET MOUNTED
STRUCTURE NO. 025-0106**

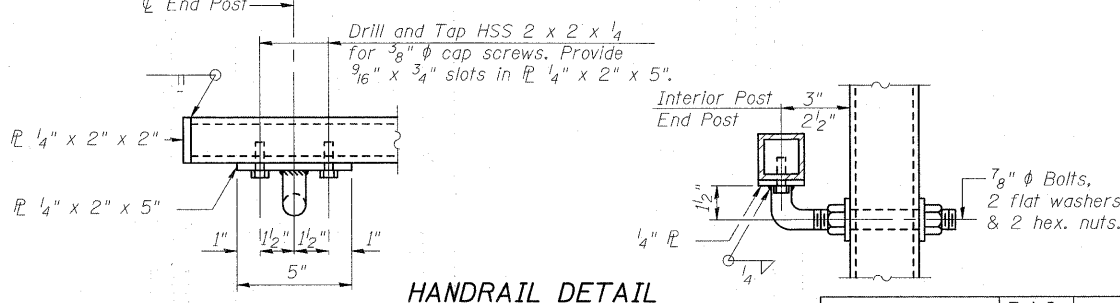

HANDRAIL DETAIL



**BERNARD
LOCHMUELLER &
ASSOCIATES, INC.**

3 Oak Drive
Mareville, IL 63062-5635
Local (618) 288-4985
Fax 618-288-4666

SHEET NO. 18 38 SHEETS	F.A.I. RTE. 57/70	SECTION (25-3HB-2)B	COUNTY EFFINGHAM	TOTAL SHEETS 839	SHEET NO. 347
	SN 025-0106		CONTRACT NO. 74293		
FED. ROAD DIST. NO. 7 ILLINOIS FED. AID PROJECT					

STATE OF ILLINOIS
DEPARTMENT OF TRANSPORTATION

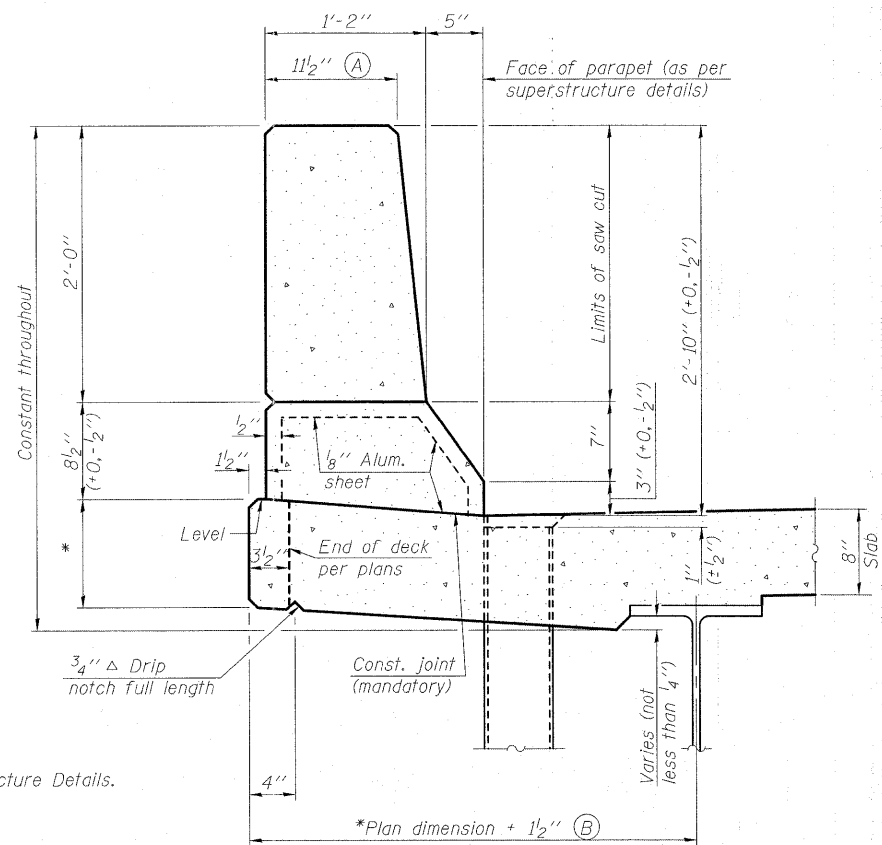

SECTION
(Showing dimensions)

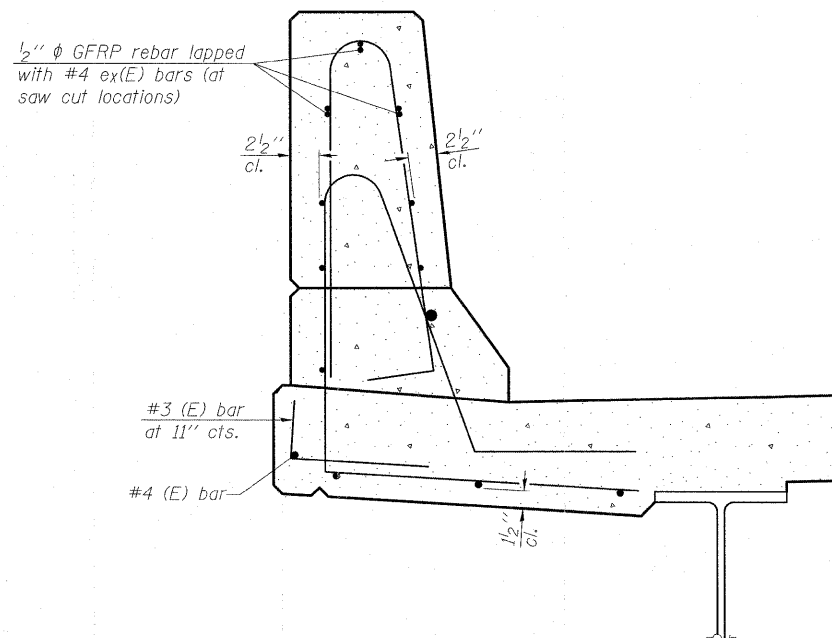

SECTION
(Showing reinforcement clearances for slip forming and additional reinforcement bars)

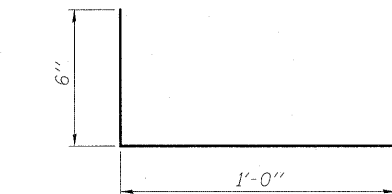

#3 (E) BAR

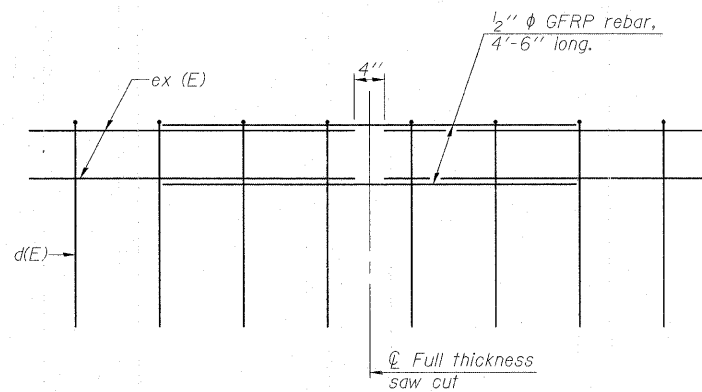

GFRP REBAR STIFFENING DETAIL

(Place as shown in parapet section at each parapet joint location.)

GENERAL NOTES

All dimensions shall remain the same as shown on superstructure details, except dimensions A and B which are to be revised as shown to provide additional clearance. Additional concrete needed to revise dimension A and B = 0.0165 cu. yds./ft. of parapet.

Place aluminum sheet in curb portion at and near piers. Full thickness saw cut at all joint locations in lieu of cork joint filler.

Steel superstructure shown. Other superstructure types similar.

Slipforming of North Parapet is not allowed.
Slipforming of 57/70 Median Parapets is not allowed.

* See Superstructure Details.

DESIGNED	
CHECKED	
DRAWN	W.J.S.
CHECKED	C.J.F.

SFP-34

11-1-09



**BERNARDIN
LOCHMUELLER &
ASSOCIATES, INC.**

3 Oak Drive
Mareville, IL 63062-5635
Local (618) 298-4665
Fax 618-298-4666

**CONCRETE PARAPET
SLIPFORMING OPTION
STRUCTURE NO. 025-0106**

SHEET NO. 19	F.A.I. RTE.	SECTION	COUNTY	TOTAL SHEETS	SHEET NO.
	57/70	(25-3HB-2)B	EFFINGHAM	839	348
38 SHEETS	SN 025-0106		CONTRACT NO. 74293		
FED. ROAD DIST. NO. 7		ILLINOIS	FED. AID PROJECT		

STATE OF ILLINOIS
DEPARTMENT OF TRANSPORTATION

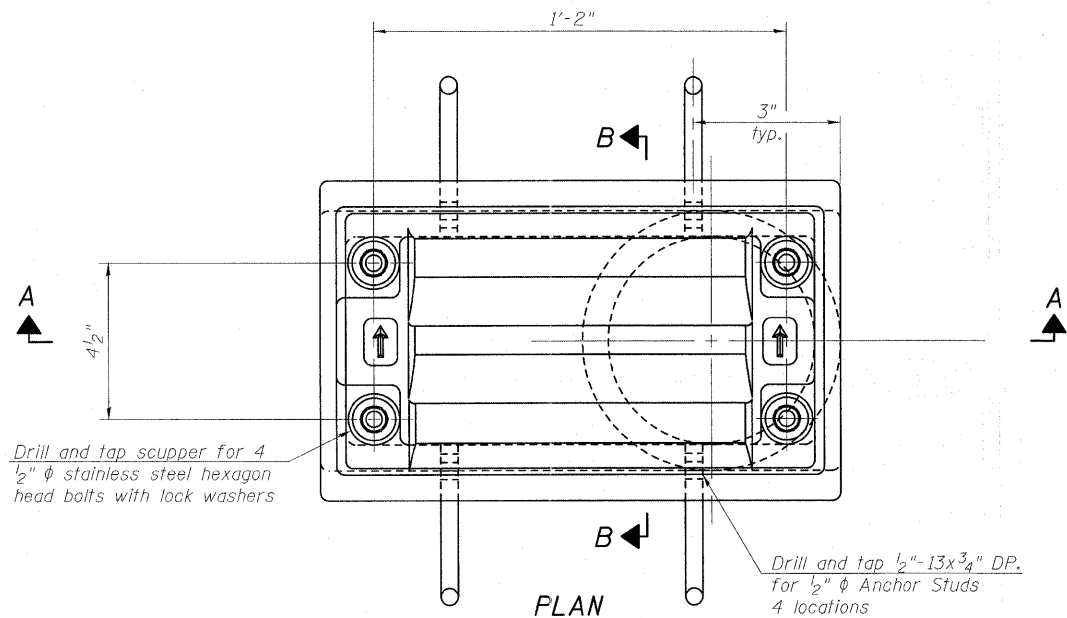

PLAN

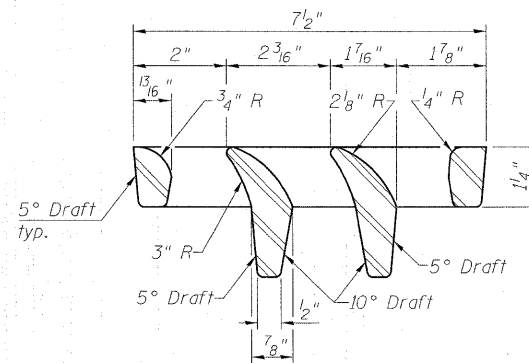

VANE GRATE DETAIL

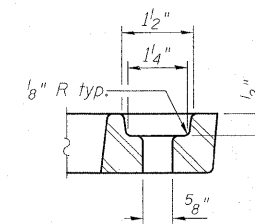

BOLT HOLE DETAIL

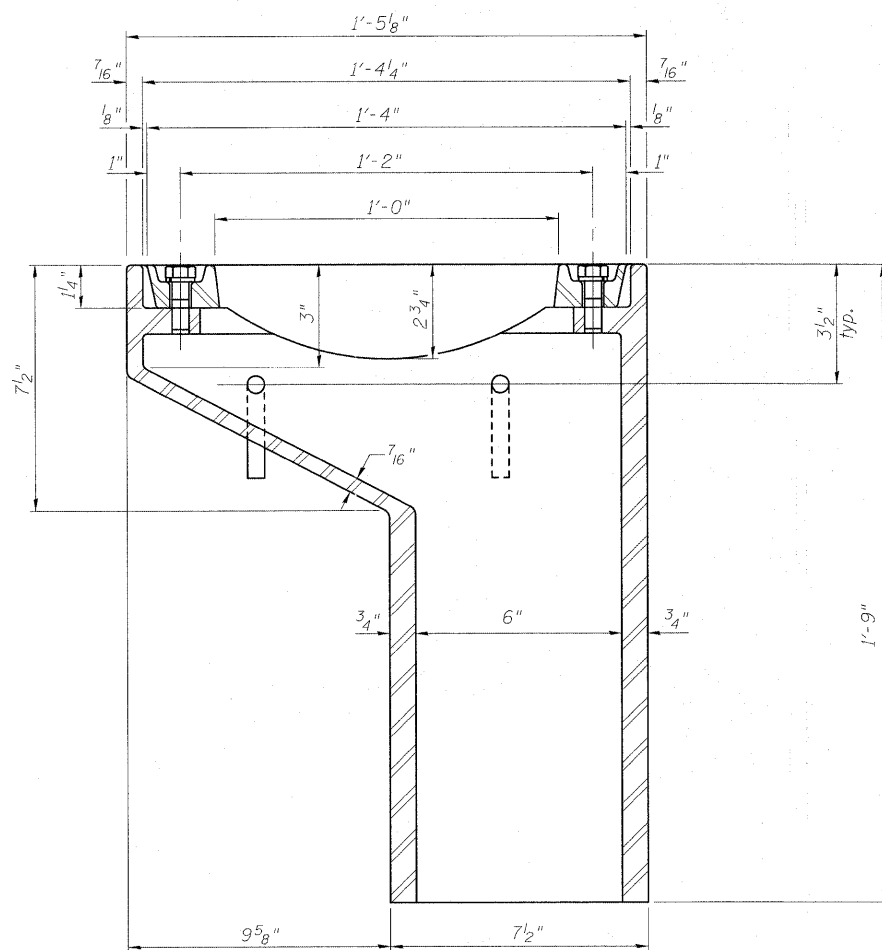

SECTION A-A

See sheets 16 & 22 of 38 for scupper location relative to parapet.

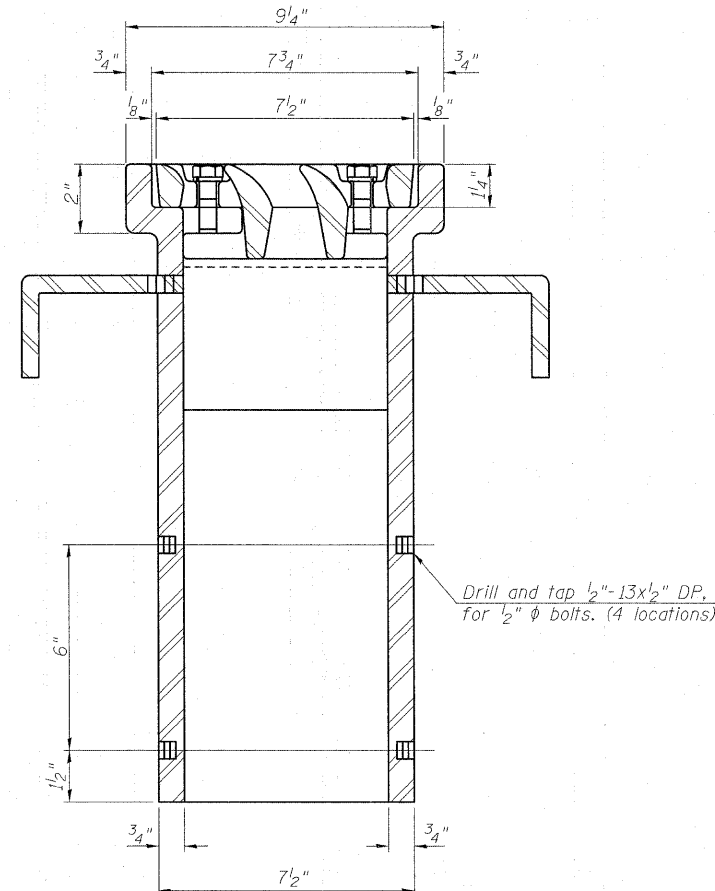

SECTION B-B

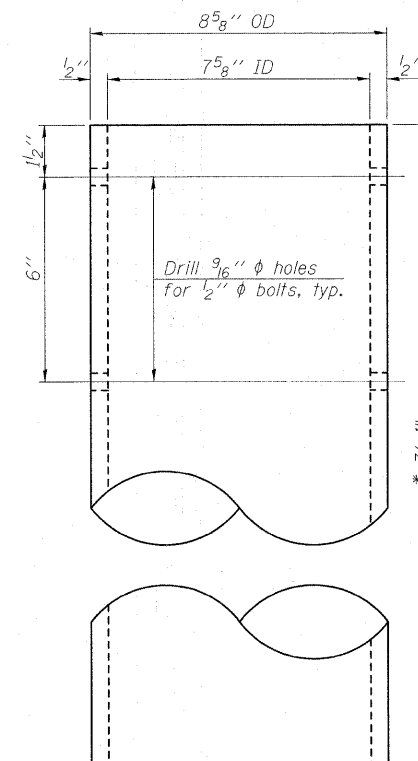

DOWNSPOUT

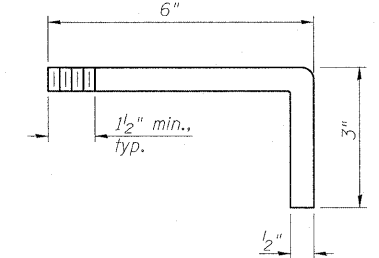

ANCHOR STUD DETAIL

* Dimension of downspout may be modified to fit Bridge Closed Drainage System.

BILL OF MATERIAL

ITEM	UNIT	QUANTITY
Drainage Scupper, DS-11	Each	8

DRAINAGE SCUPPER, DS-11
STRUCTURE NO. 025-0106

DESIGNED	
CHECKED	
DRAWN	W.J.S.
CHECKED	C.J.F.

DS-11

11-1-09



BERNARDIN
LOCHMUELLER &
ASSOCIATES, INC.

3 Oak Drive
Maryville, IL 62442-5835
Local (618) 288-4955
Fax 618-288-4956

SHEET NO. 20 38 SHEETS	F.A.I. RTE. 57/70	SECTION (25-3HB-2)B	COUNTY EFFINGHAM	TOTAL SHEETS 839	SHEET NO. 349
	SN 025-0106		CONTRACT NO. 74293		
FED. ROAD DIST. NO. 7 ILLINOIS FED. AID PROJECT					

STATE OF ILLINOIS
DEPARTMENT OF TRANSPORTATION

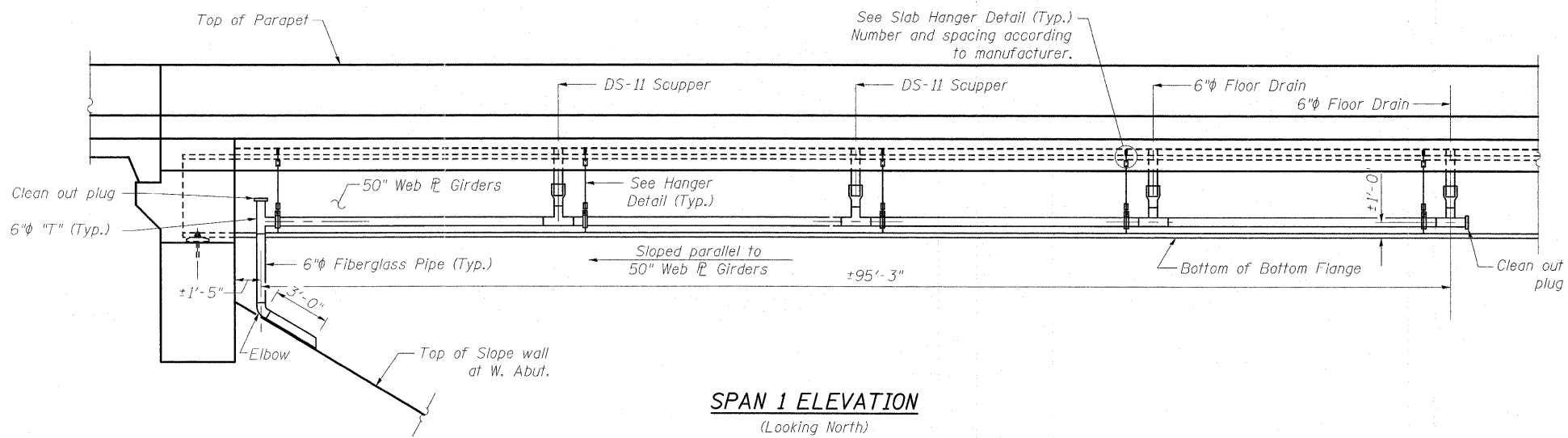

SPAN 1 ELEVATION

(Looking North)
(Showing South Drainage System)
(North System similar)

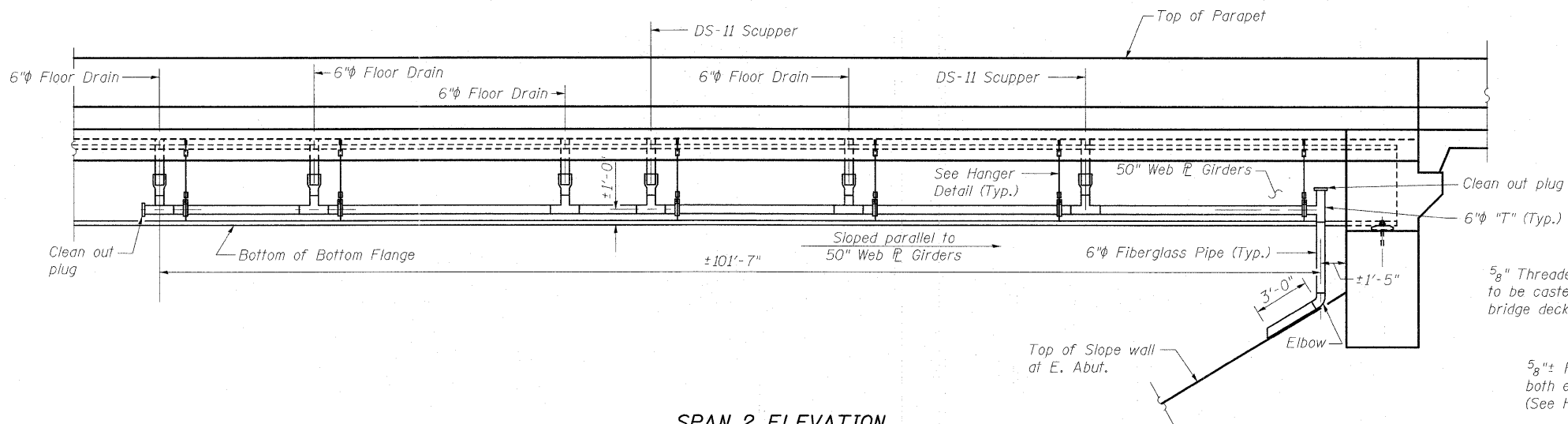

SPAN 2 ELEVATION

(Looking North)
(Showing South Drainage System)
(North System similar)

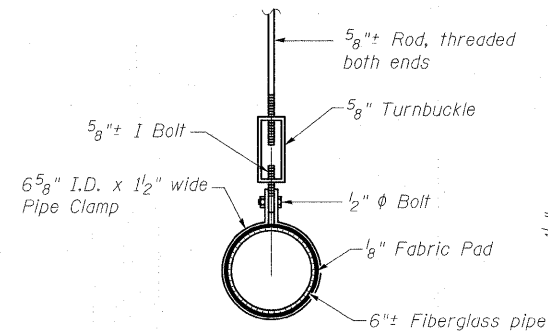

HANGER DETAIL

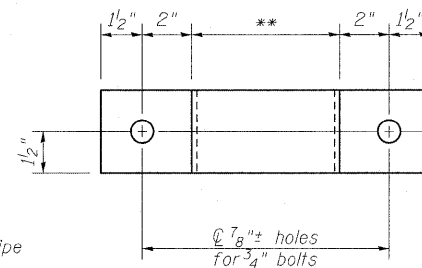

3/8" x 3" STRAP DETAIL

* Dimension as required by the pipe strap.
** Dimension as required by the pipe.

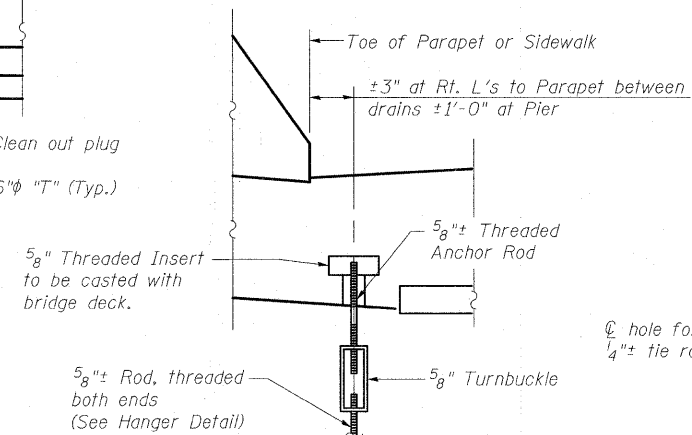

SLAB HANGER DETAIL

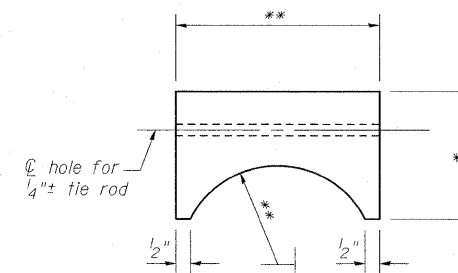

RUBBER SHIM DETAIL

Note:
See Sheet 1 of 38 for Floor drain & Scupper spacing.
See Sheet 22 of 38 for Slab Hanger Detail

DESIGNED	A.C.S.
CHECKED	B.B.
DRAWN	W.J.S.
CHECKED	C.J.F.



**BERNARD
LOCHMUELLER &
ASSOCIATES, INC.**

3 Oak Drive
Mareville, IL 62662-5635
Local (618) 298-4665
Fax (618) 298-4666

SHEET NO. 21 38 SHEETS	F.A.I. RTE. 57/70	SECTION (25-3HB-2)B	COUNTY EFFINGHAM	TOTAL SHEETS 839	SHEET NO. 350
	SN 025-0106		CONTRACT NO. 74293		
FED. ROAD DIST. NO. 7 ILLINOIS FED. AID PROJECT					

**DRAINAGE SYSTEM
STRUCTURE NO. 025-0106**

STATE OF ILLINOIS
DEPARTMENT OF TRANSPORTATION

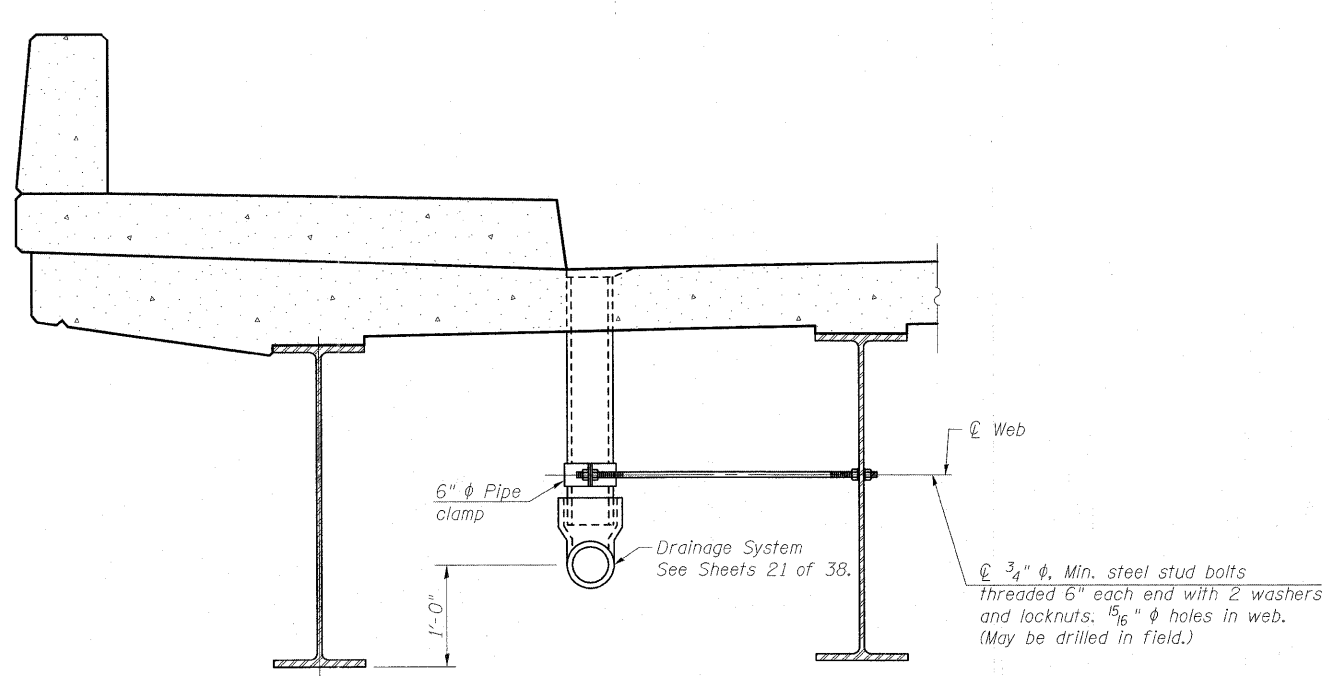

SECTION THRU SIDEWALK

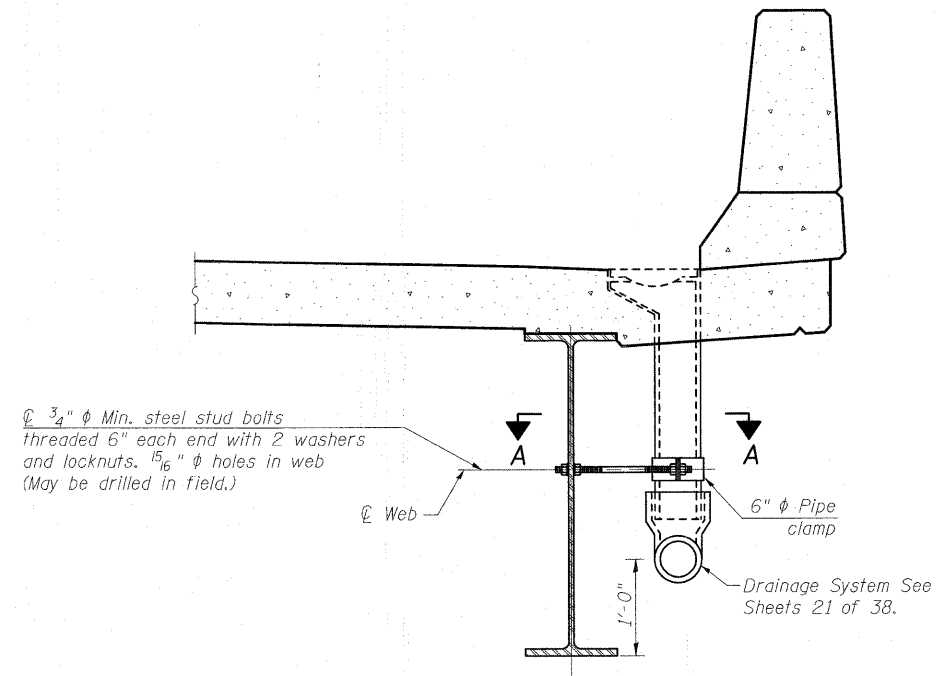

SECTION THRU SOUTH PARAPET

Notes:

Drains & Bridge Drainage System shall be located clear of all diaphragms.
The exterior surfaces of the floor drains shall be painted with the finish coat as specified in the special provisions for Cleaning and Painting New Metal Structures. The exterior surfaces of the drains shall be cleaned according to the Society of Protective Coatings' Spec. SSPC-SP1 prior to painting.
Fiberglass pipe shall conform to ASTM D 2996, with short-time rupture strength hoop tensile stress of 30,000 p.s.i. minimum.
Galvanize clamping device according to AASHTO M232. Cost of clamping device and inserts is included with Floor Drains.
For Scupper Details See Sheet 20 of 38.

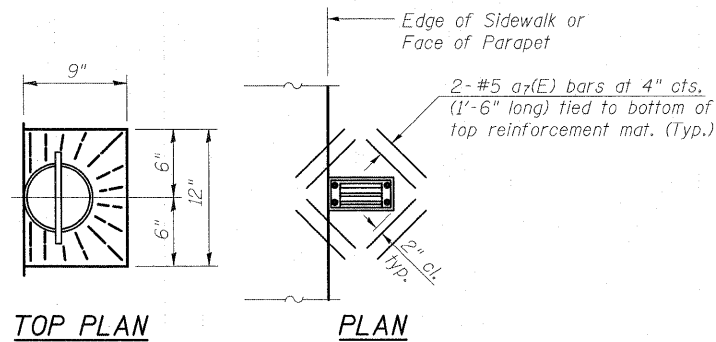

TOP PLAN

PLAN

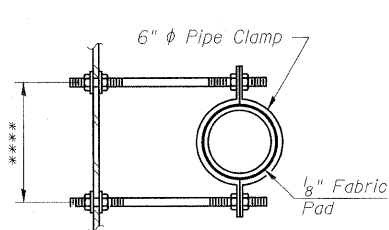

SECTION A-A

****Dimension as required by Pipe Clamp

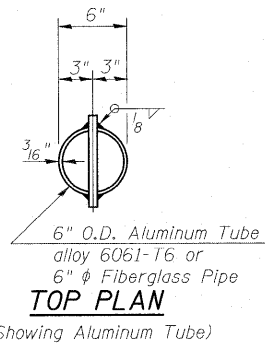

TOP PLAN

(Showing Aluminum Tube)

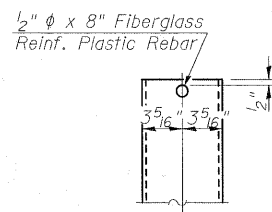

FIBERGLASS PIPE

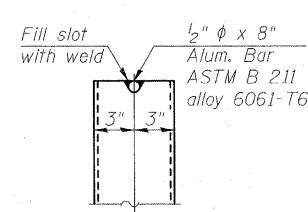

ALUMINUM TUBE

BILL OF MATERIAL

Item	Unit	Total
Drainage System	L. Sum	1
Floor Drains	Each	12

DESIGNED	A.C.S.
CHECKED	B.B.
DRAWN	W.J.S.
CHECKED	C.J.F.

DRAINAGE SYSTEM
STRUCTURE NO. 025-0106



BERNARDIN
LOCHMUELLER &
ASSOCIATES, INC.

3 Oak Drive
Maryville, IL 62962-5665
Local (618) 398-4665
Fax 618-398-4666

SHEET NO. 22	F.A.I. RTE.	SECTION	COUNTY	TOTAL SHEETS	SHEET NO.
	57/70	(25-3HB-2)B	EFFINGHAM	839	351
38 SHEETS	SN 025-0106		CONTRACT NO. 74293		
FED. ROAD DIST. NO. 7 ILLINOIS FED. AID PROJECT					

STATE OF ILLINOIS
DEPARTMENT OF TRANSPORTATION

Notes:
See sheet 25 of 38 for Sections A-A, B-B, C-C, D-D and E-E, and Views F-F and G-G.
 $a_8(E)$, $a_9(E)$, $a_{11}(E)$ and $a_{12}(E)$ bar spacings measured along CL Rdwy.
Stage III Construction shall consist of installation of the Superimposed Median.

 Indicates Superimposed Raised Median
See sheet 16 of 38 for Raised Median reinforcement.

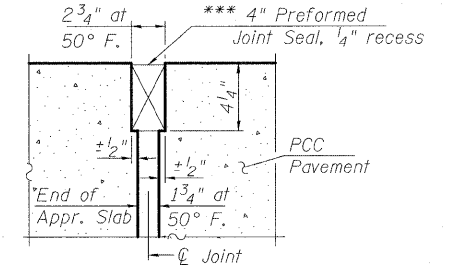
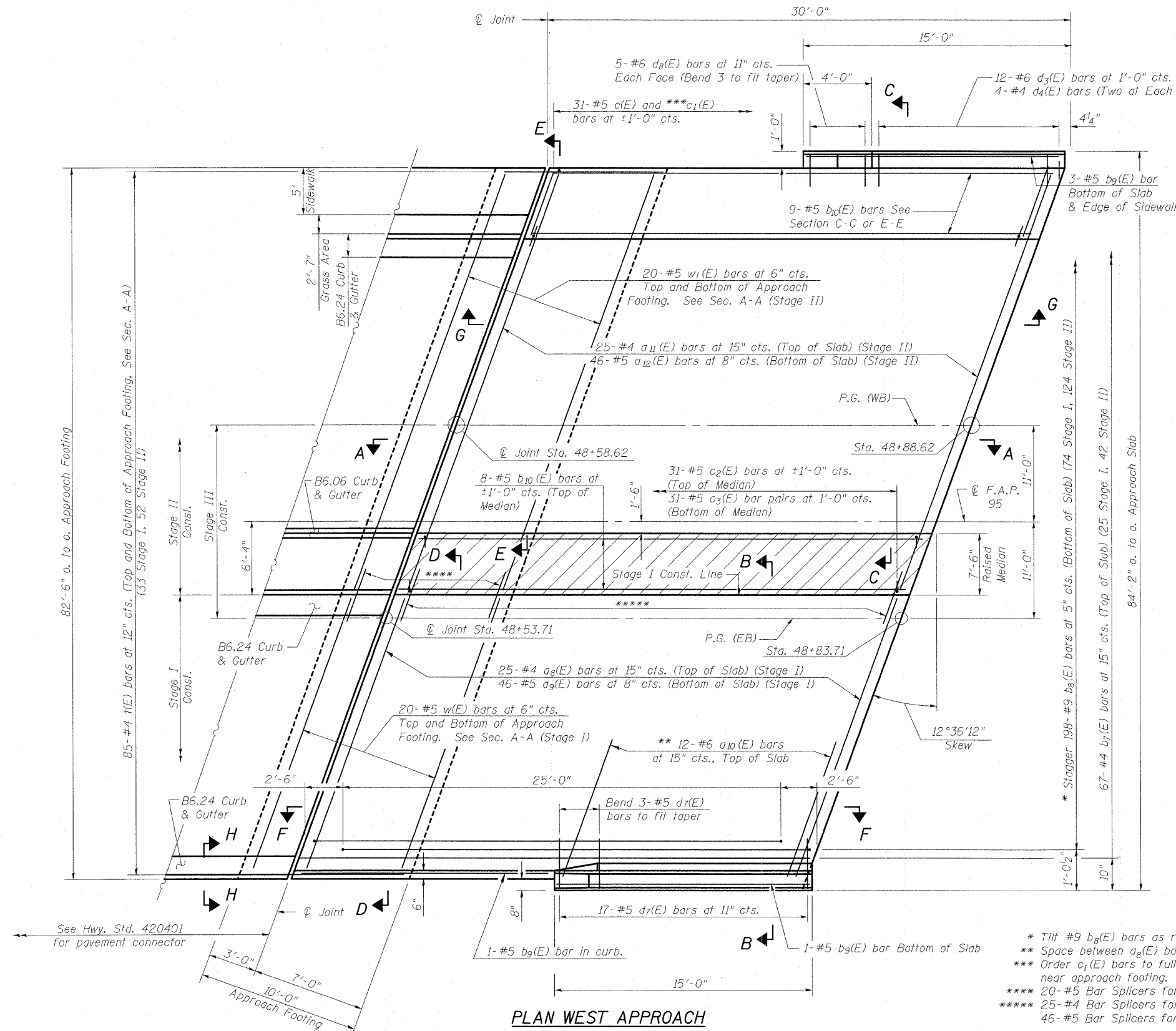

*** Cost included with Concrete Superstructure.
**RIGID PAVEMENT
DETAIL A**

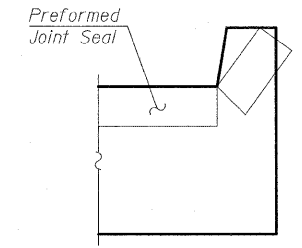

VIEW H-H
Angle Preformed Joint Seal at 45° at curbs when req'd for drainage.

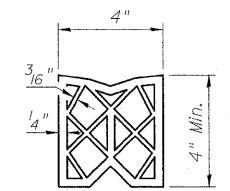

**PREFORMED
JOINT SEAL**

**WEST BRIDGE APPROACH
SLAB DETAILS
STRUCTURE NO. 025-0106**

- * Tilt #9 $b_8(E)$ bars as required to maintain clearance.
- ** Space between $a_8(E)$ bars.
- *** Order $c_1(E)$ bars to full length. Cut to fit in sidewalk near approach footing.
- **** 20-#5 Bar Splicers for $w(E)$ bars Top & Bottom
- ***** 25-#4 Bar Splicers for $a_8(E)$ bars Top of Slab and 46-#5 Bar Splicers for $a_9(E)$ bars Bottom of Slab

DESIGNED	A.C.S.
CHECKED	B.B.
DRAWN	W.J.S.
CHECKED	C.J.F.

 **BERNARDIN
LOCHMUELLER &
ASSOCIATES, INC.**

3 Oak Drive
Merrville, IL 61863-2685
Local (618) 288-4655
Fax (618) 288-4686

SHEET NO. 23 38 SHEETS	F.A.I. RTE.	SECTION	COUNTY	TOTAL SHEETS	SHEET NO.
	57/70	(25-3HB-2)B	EFFINGHAM	839	352
SN 025-0106			CONTRACT NO. 74293		
FED. ROAD DIST. NO. 7 ILLINOIS FED. AID PROJECT					

025B03 AM 8/12/2010 10:25:06 PM 23.dgn

STATE OF ILLINOIS
DEPARTMENT OF TRANSPORTATION

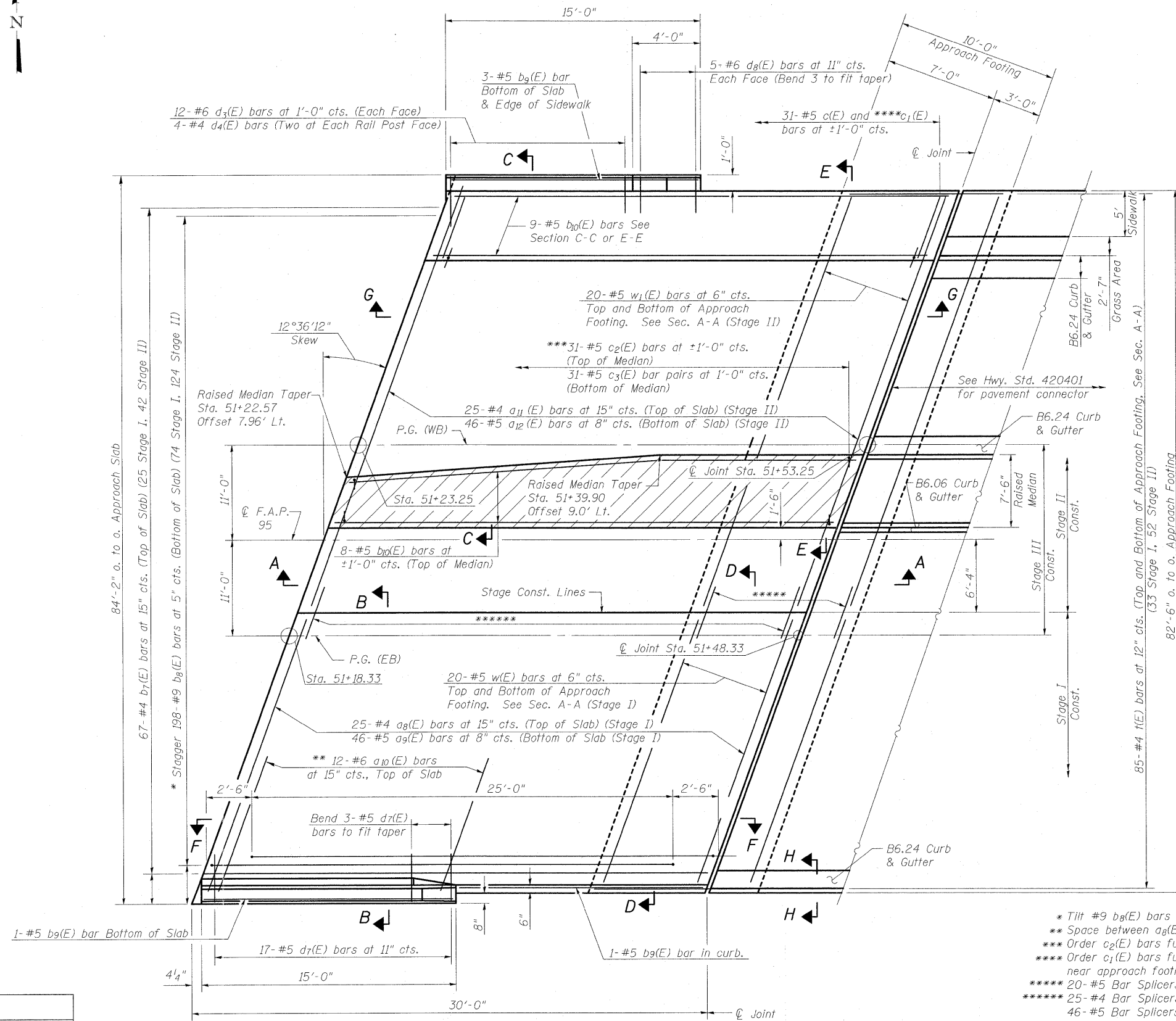
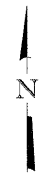

Notes:
See sheet 25 of 38 for Sections A-A, B-B, C-C, D-D and E-E, and Views F-F and G-G.
a8(E), a9(E), a11(E) and a12(E) bar spacings measured along @ Rdwy.
Bend b10(E) bars in field to fit median taper.
See sheet 23 of 38 for View H-H.
Stage III Construction shall consist of installation of the Superimposed Median.

Indicates Superimposed Raised Median
See sheet 16 of 38 for Raised Median reinforcement.

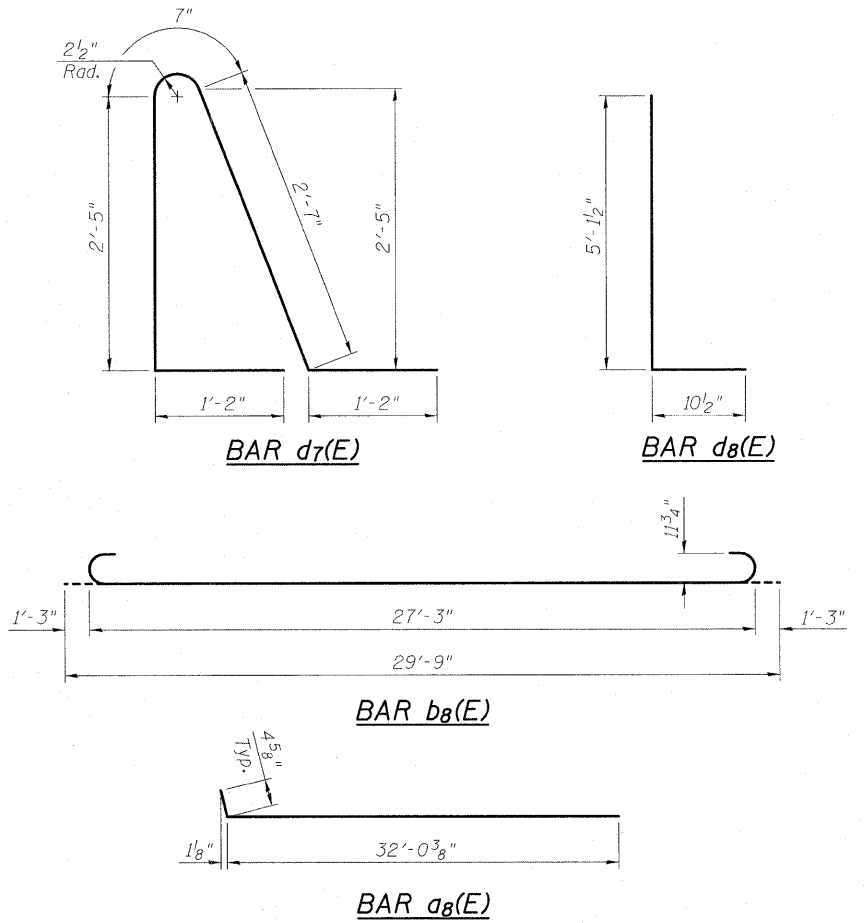

- * Tilt #9 b8(E) bars as required to maintain clearance.
- ** Space between a8(E) bars.
- *** Order c2(E) bars full length. Cut to fit in median.
- **** Order c1(E) bars full length. Cut to fit in sidewalk near approach footing.
- ***** 20-#5 Bar Splicers for w(E) bars Top & Bottom
- ***** 25-#4 Bar Splicers for a8(E) bars Top of Slab and 46-#5 Bar Splicers for a9(E) bars Bottom of Slab

**EAST BRIDGE APPROACH
SLAB DETAILS
STRUCTURE NO. 025-0106**

DESIGNED	A.C.S.
CHECKED	B.B.
DRAWN	W.J.S.
CHECKED	C.J.F.

PLAN EAST APPROACH



**BERNARDIN
LOCHMUELLER &
ASSOCIATES, INC.**

3 Oak Drive
Maryville, IL 62902-9688
Local (618) 288-4666
Fax 618-288-4666

SHEET NO. 24 38 SHEETS	F.A.I. RTE. 57/70	SECTION (25-3HB-2)B	COUNTY EFFINGHAM	TOTAL SHEETS 839	SHEET NO. 353
	SN 025-0106			CONTRACT NO. 74293	
FED. ROAD DIST. NO. 7 ILLINOIS FED. AID PROJECT					

STATE OF ILLINOIS
DEPARTMENT OF TRANSPORTATION

Notes:

See sheet 23 of 38 for Detail A.
Approach slab and parapet concrete shall be paid for as Concrete Superstructure.
Approach footing concrete shall be paid for as Concrete Structures.
Reinforcement shall be paid for as Reinforcement Bars, Epoxy Coated.
For v(E), c(E), c₃(E), d₃(E) and d₄(E) bar details, see sheet 16 of 38.
The approach footing maximum applied service bearing pressure (Q_{max}) = 2.0 ksf.
For bar splicer details, see sheet 34 of 38.
Cost of excavation for approach footing included with Concrete Structures.
For Porous Granular Embankment (Special) and drainage treatment details, see sheet 2 of 38.
For additional parapet details, see sheet 16 of 38.
Superimposed Median not shown for clarity, see sheet 16 of 38.

* Tilt #9 b₈(E) bars as required to maintain clearance.
** Cost included with Concrete Superstructure.
*** Cut c₁(E) bars to fit.

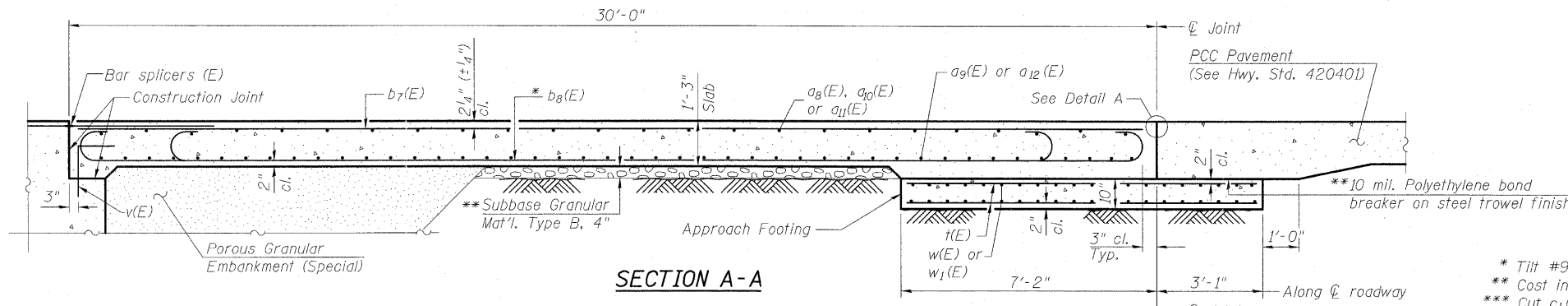

SECTION A-A

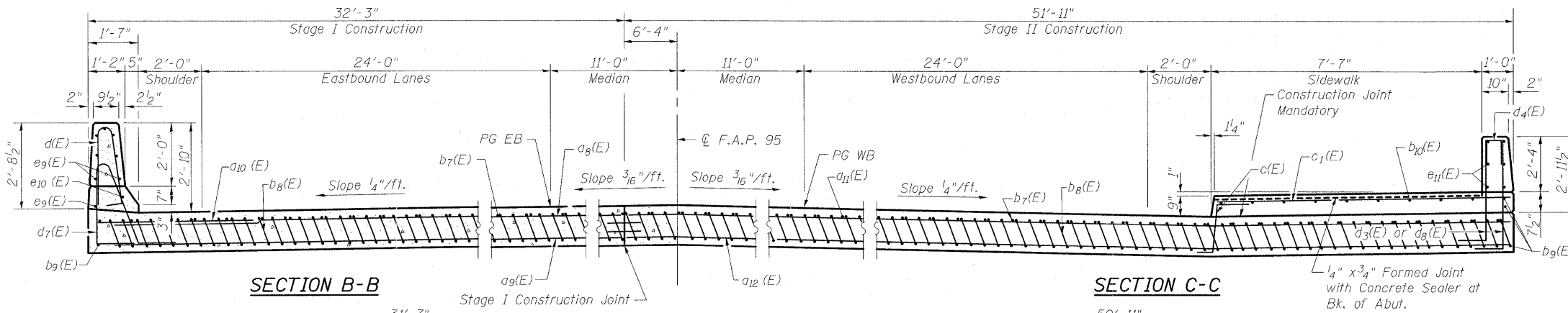

SECTION B-B

SECTION C-C

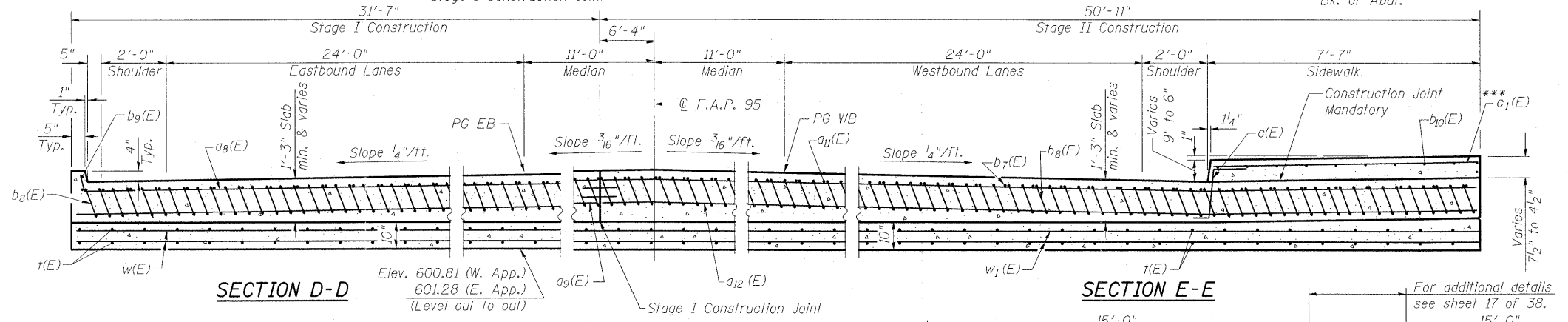

SECTION D-D

SECTION E-E

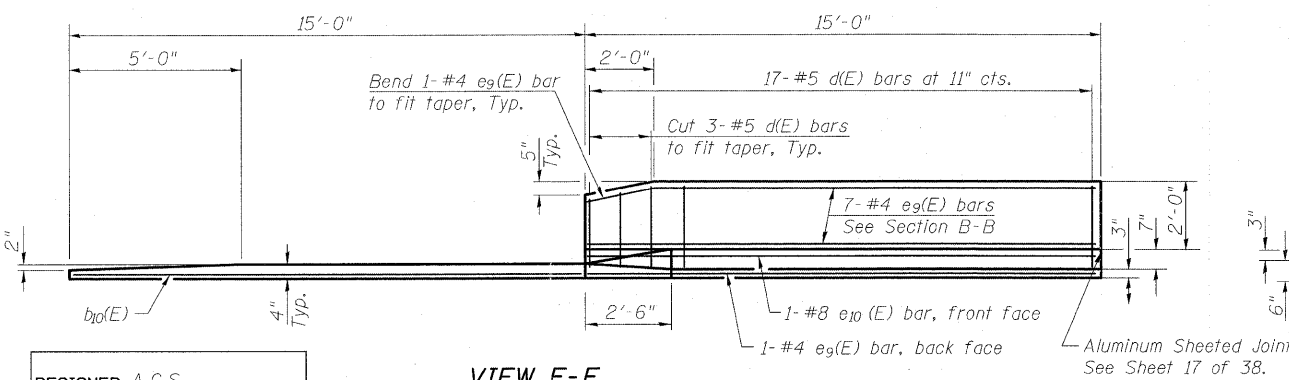

VIEW F-F

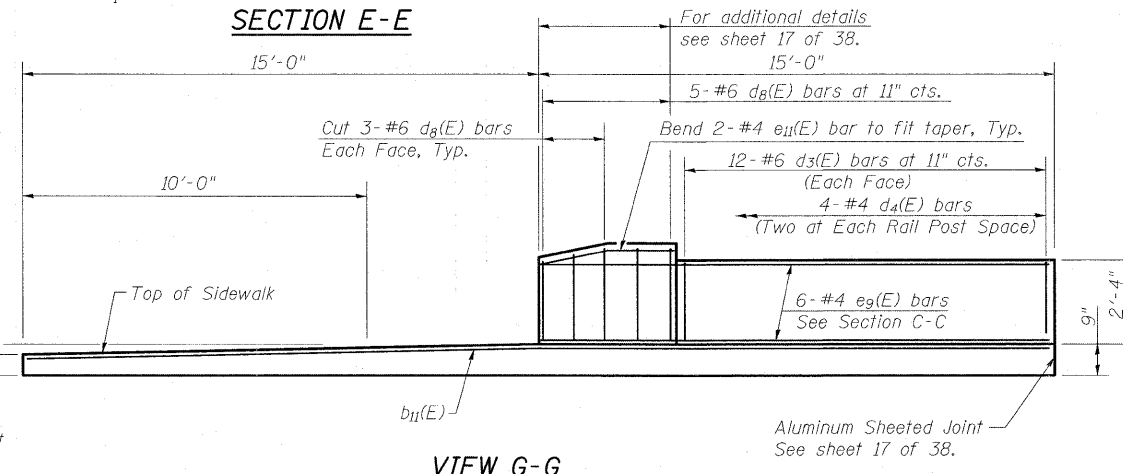

VIEW G-G

TWO APPROACHES
BILL OF MATERIAL

Bar	No.	Size	Length	Shape
a ₈ (E)	50	#4	32'-5"	—
a ₉ (E)	92	#5	32'-1"	—
a ₁₀ (E)	24	#6	6'-6"	—
a ₁₁ (E)	50	#4	51'-11"	—
a ₁₂ (E)	92	#5	51'-11"	—
b ₇ (E)	134	#4	29'-8"	—
b ₈ (E)	396	#9	29'-9"	—
b ₉ (E)	10	#5	14'-9"	—
b ₁₀ (E)	34	#5	29'-9"	—
c(E)	62	#5	2'-5"	—
c ₁ (E)	62	#5	8'-2"	—
c ₂ (E)	62	#5	6'-10"	—
c ₃ (E)	124	#5	1'-4"	—
d(E)	34	#5	5'-7"	—
d ₃ (E)	48	#6	4'-6"	—
d ₄ (E)	8	#4	2'-0"	—
d ₇ (E)	34	#5	7'-11"	—
d ₈ (E)	20	#6	6'-0"	—
e ₉ (E)	28	#4	14'-9"	—
e ₁₀ (E)	2	#8	14'-9"	—
e ₁₁ (E)	4	#4	3'-9"	—
h(E)	340	#4	10'-0"	—
w(E)	80	#5	32'-1"	—
w ₁ (E)	80	#5	52'-3"	—
Concrete Superstructure	Cu. Yd.		261.9	
Concrete Structures	Cu. Yd.		52.4	
Reinforcement Bars, Epoxy Coated	Pound		67070	
Bar Splicers	Each		222	

BRIDGE APPROACH SLAB DETAILS
STRUCTURE NO. 025-0106

DESIGNED	A.C.S.
CHECKED	B.B.
DRAWN	W.J.S.
CHECKED	C.J.F.

(E. Approach Slab shown)
(W. Approach Slab similar, opposite hand)

(W. Approach Slab shown)
(E. Approach Slab similar, opposite hand)



BERNARD
LOCHMUELLER &
ASSOCIATES, INC.

3 Oak Drive
Maryville, IL 62452-5655
Local (618) 388-4665
Fax 618-388-4666

SHEET NO. 25 38 SHEETS	F.A.I. RTE.	SECTION	COUNTY	TOTAL SHEETS	SHEET NO.
	57/70	(25-3HB-2)B	EFFINGHAM	839	354
		SN 025-0106	CONTRACT NO. 74293		
FED. ROAD DIST. NO. 7 ILLINOIS FED. AID PROJECT					

STATE OF ILLINOIS
DEPARTMENT OF TRANSPORTATION

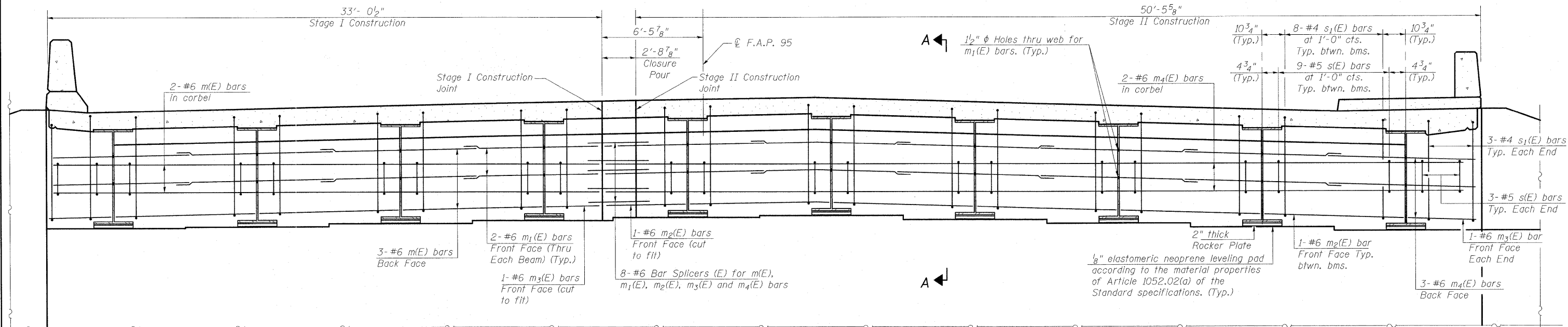

DIAPHRAGM ELEVATION AT ABUTMENT
(Looking West)

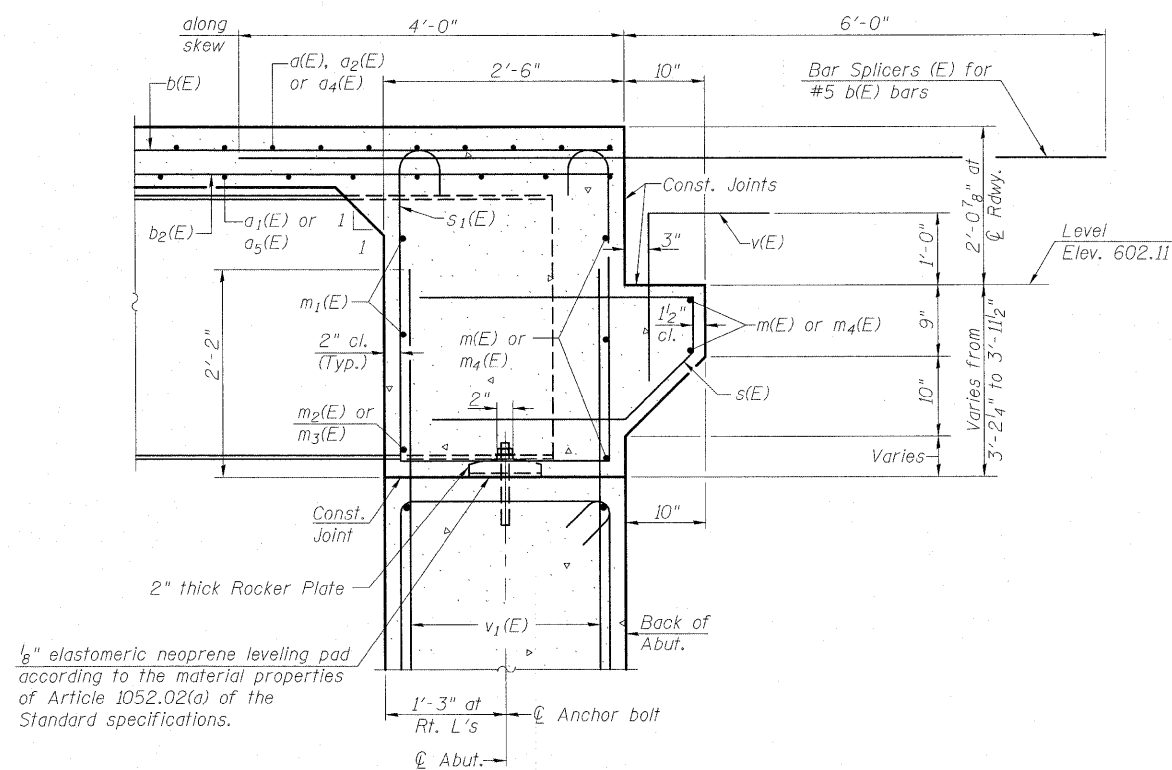

SECTION A-A

Dimensions at right angles to abutment, except as shown.

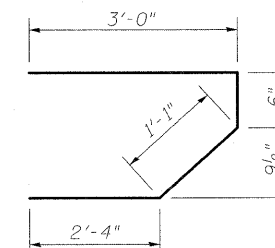

BAR s(E)

MIN. BAR LAP
#6 bar = 3'-4"

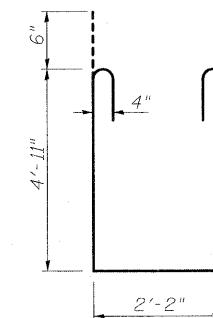

BAR s₁(E)

Notes:
Reinforcement bars in diaphragm are billed with superstructure on sheet 16 of 38.
Concrete in diaphragm is included with Concrete Superstructure on sheet 16 of 38.
The s(E) and s₁(E) bars shall be placed parallel to the beams. Spacing for these bars shall be at right angles to the beams.
Superimposed Median not shown for clarity.

WEST ABUTMENT
DIAPHRAGM DETAILS
STRUCTURE NO. 025-0106

DESIGNED	A.C.S.
CHECKED	B.B.
DRAWN	W.J.S.
CHECKED	C.J.F.



BERNARDIN
LOCHMUELLER &
ASSOCIATES, INC.

3 Oak Drive
Merriville, IL 60062-4635
Local (618) 288-4665
Fax 618-288-4666

SHEET NO. 26 38 SHEETS	F.A.I. RTE.	SECTION	COUNTY	TOTAL SHEETS	SHEET NO.
	57/70	(25-3HB-2)B	EFFINGHAM	839	355
SN 025-0106			CONTRACT NO. 74293		
FED. ROAD DIST. NO. 7 ILLINOIS FED. AID PROJECT					

STATE OF ILLINOIS
DEPARTMENT OF TRANSPORTATION

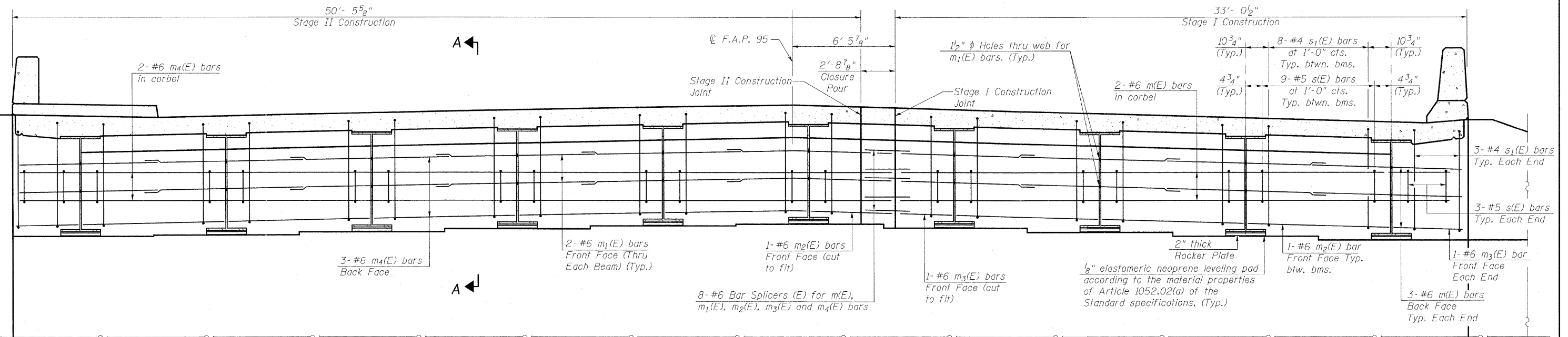

DIAPHRAGM ELEVATION AT ABUTMENT
(Looking East)

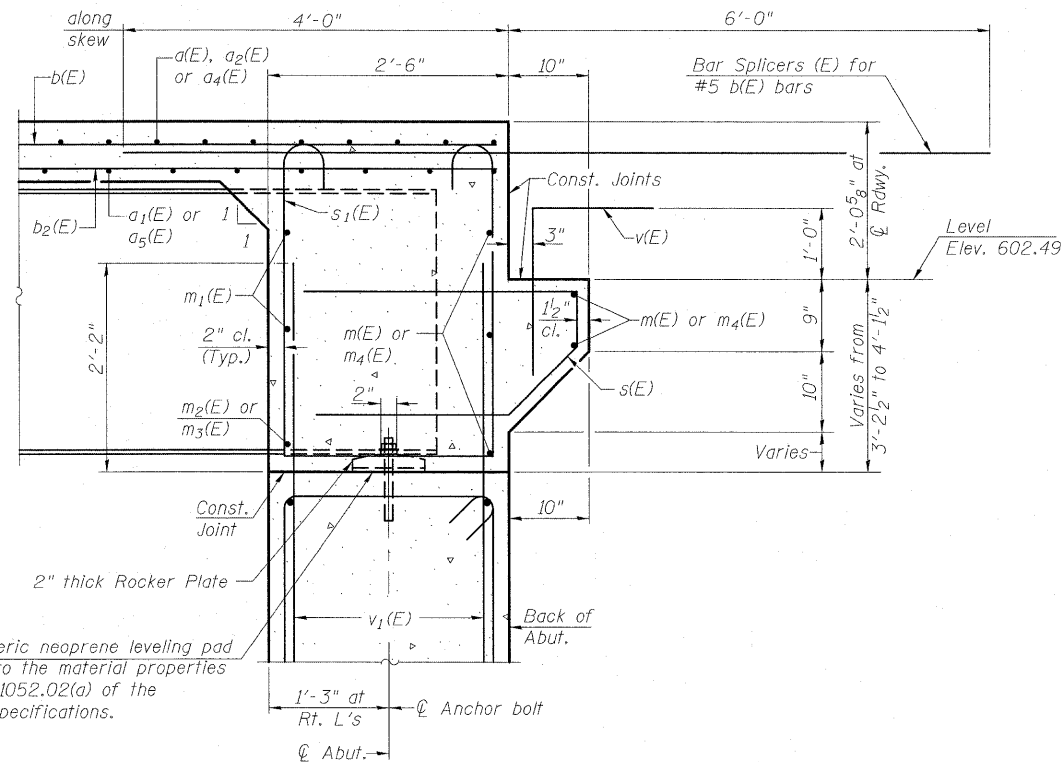

SECTION A-A

Dimensions at right angles to abutment, except as shown.

MIN. BAR LAP
#6 bar = 3'-4"

Notes:
Reinforcement bars in diaphragm are billed with superstructure on sheet 16 of 38.
Concrete in diaphragm is included with Concrete Superstructure on sheet 16 of 38.
For details of bars s(E) & s₁(E) see sheet 26 of 38.
The s(E) and s₁(E) bars shall be placed parallel to the beams. Spacing for these bars shall be at right angles to the beams.
Superimposed Median not shown for clarity.

DESIGNED	A.C.S.
CHECKED	B.B.
DRAWN	W.J.S.
CHECKED	C.J.F.



**BERNARDIN
LOCHMUELLER &
ASSOCIATES, INC.**

3 Oak Drive
Marengo, IL 60442-5655
Local (618) 298-4665
Fax 618-298-4666

SHEET NO. 27 38 SHEETS	F.A.I. RTE.	SECTION	COUNTY	TOTAL SHEETS	SHEET NO.
	57/70	(25-3HB-2)B	EFFINGHAM	839	356
SN 025-0106			CONTRACT NO. 74293		
FED. ROAD DIST. NO. 7 ILLINOIS FED. AID PROJECT					

**EAST ABUTMENT
DIAPHRAGM DETAILS
STRUCTURE NO. 025-0106**

STATE OF ILLINOIS
DEPARTMENT OF TRANSPORTATION

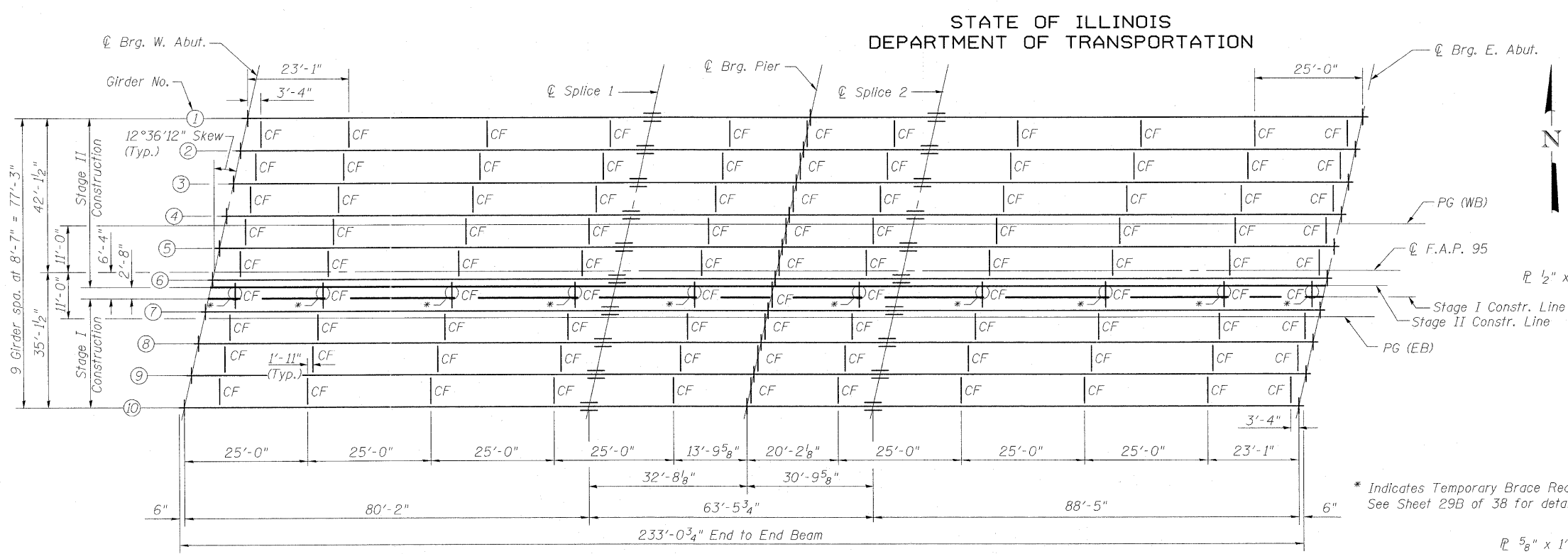

FRAMING PLAN

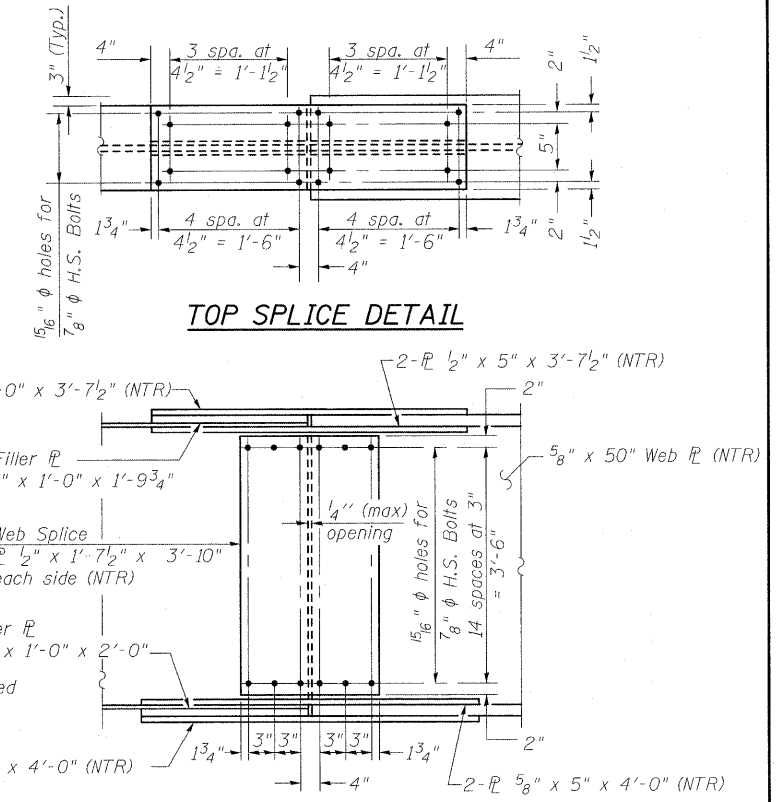

TOP SPLICE DETAIL

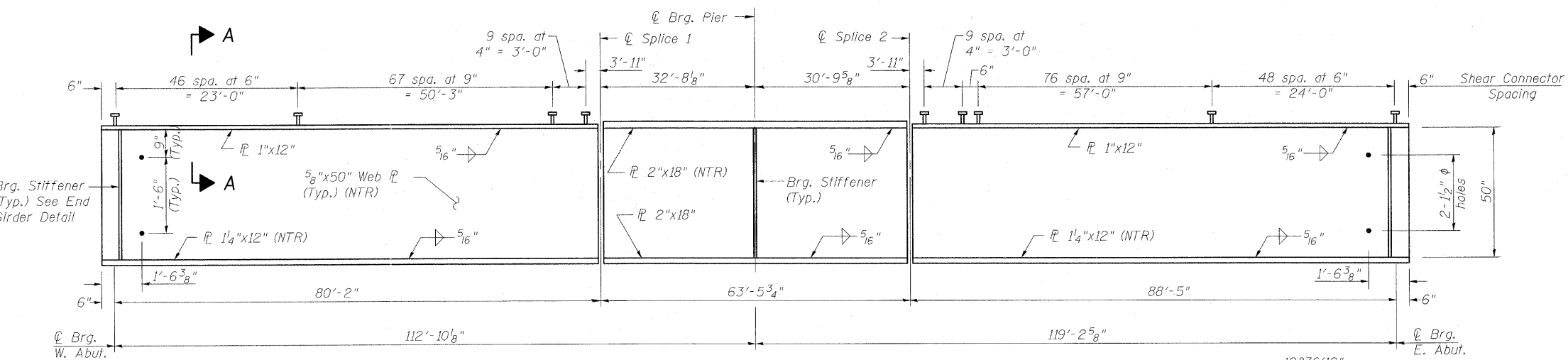

GIRDER ELEVATION

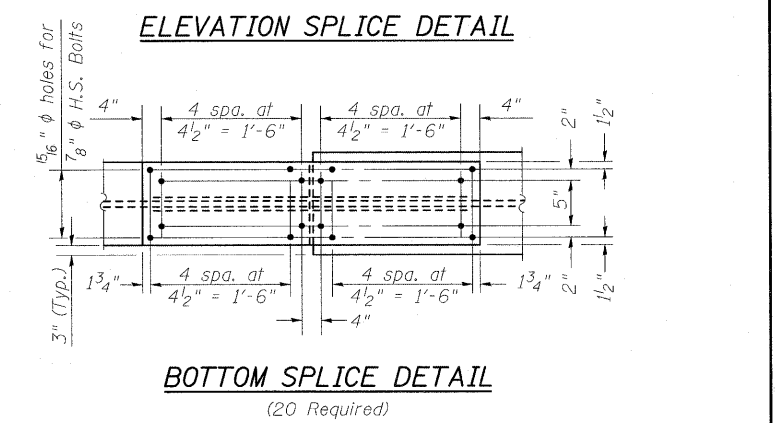

BOTTOM SPLICE DETAIL

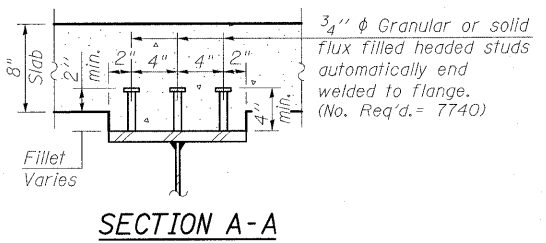

SECTION A-A

***TOP OF WEB ELEVATIONS

Location	℄ Brg. W. Abut	℄ Splice 1	℄ Pier	℄ Splice 2	℄ Brg. E. Abut
Girder 1	602.68	603.23	603.22	603.33	602.82
Girder 2	602.84	603.40	603.39	603.51	603.02
Girder 3	602.98	603.57	603.56	603.69	603.22
Girder 4	603.15	603.74	603.74	603.87	603.41
Girder 5	603.28	603.89	603.90	604.04	603.59
Girder 6	603.37	603.99	604.00	604.15	603.73
Girder 7	603.20	603.85	603.85	604.02	603.60
Girder 8	603.00	603.67	603.70	603.85	603.46
Girder 9	602.79	603.48	603.51	603.67	603.29
Girder 10	602.60	603.29	603.33	603.50	603.13

***For Fabrication Only

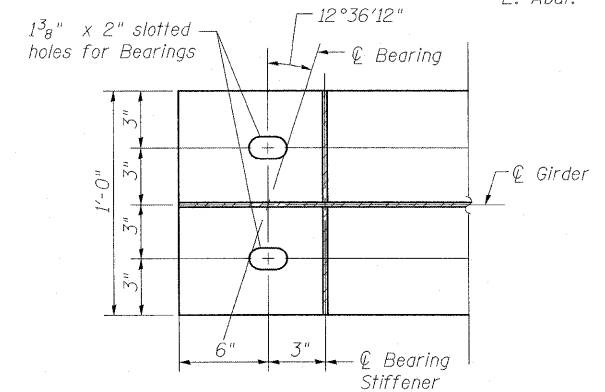

END GIRDER DETAIL

Notes:
See Sheet 29 of 38 for Camber Diagram.
Two hardened washers required for each set of oversized holes.
All splice plates shall be M270 Grade 50 (NTR).
All cross frames or diaphragms shall be installed as steel is erected and secured with erection pins and bolts except as otherwise noted. Individual cross frames or diaphragms at supports may be temporarily disconnected to install bearing anchor rods.
Load carrying components designated "NTR" shall conform to the Supplemental Requirements for Notch Toughness, Zone 2.
"NTR" denotes plates to which notch toughness requirements are applicable.
For details of Crossframes See Sheet 29B of 38.
For details of Bearing Stiffeners See Sheet 29B of 38.

STRUCTURAL STEEL
STRUCTURE NO. 025-0106

DESIGNED	A.C.S.
CHECKED	B.B.
DRAWN	W.J.S.
CHECKED	C.J.F.

SHEET NO. 28 38 SHEETS	F.A.I. RTE. 57/70	SECTION (25-3HB-2)B	COUNTY EFFINGHAM	TOTAL SHEETS 839	SHEET NO. 357
	SN 025-0106		CONTRACT NO. 74293		
FED. ROAD DIST. NO. 7 ILLINOIS FED. AID PROJECT					

BERNARDIN LOCHMUELLER & ASSOCIATES, INC.
3 Oak Drive
Maryville, IL 62450-5655
Local (618) 288-4665
Fax 618-288-4666

STATE OF ILLINOIS
DEPARTMENT OF TRANSPORTATION

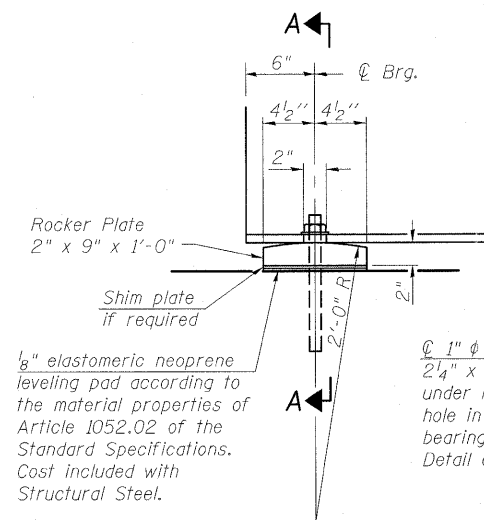

ELEVATION AT ABUTMENT

FIXED BEARING
(20 Required)

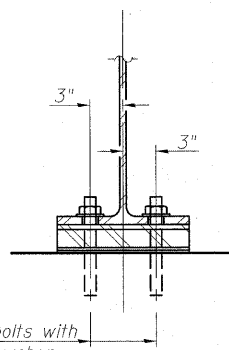

SECTION A-A

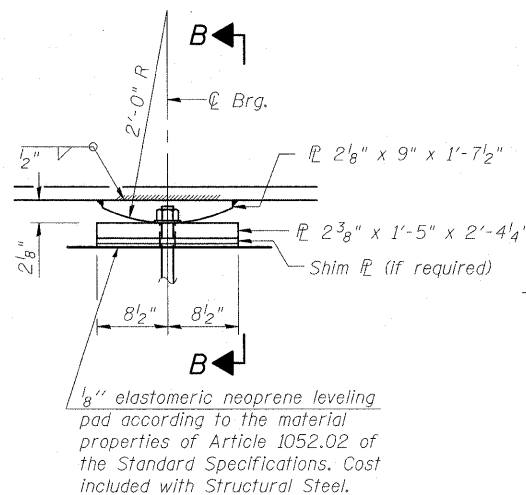

ELEVATION AT PIER

FIXED BEARING
(10 Required)

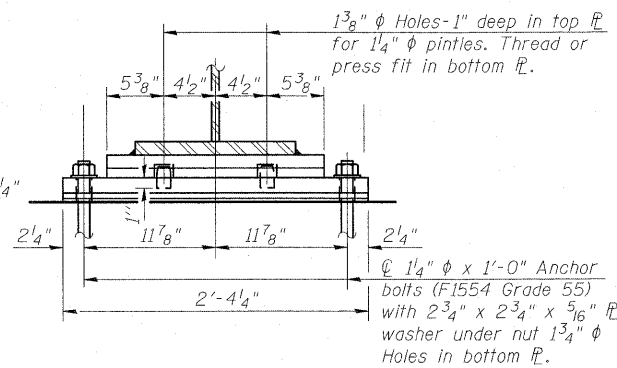

SECTION B-B

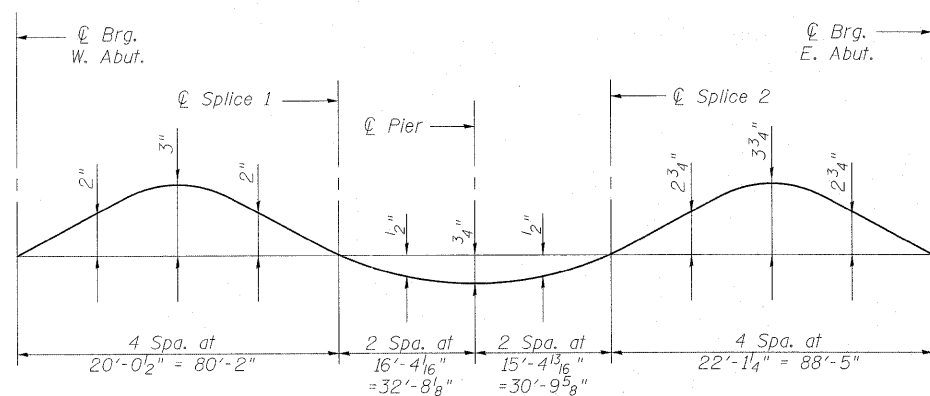

CAMBER DIAGRAM

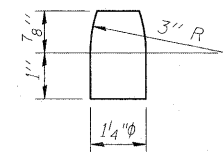

PINTLE

INTERIOR GIRDER MOMENT TABLE				
		0.4 Sp. 1	Pier	0.6 SP 2
I_s	(in ⁴)	24061	55206	24061
$I_c(n)$	(in ⁴)	59757	-	59757
$I_c(3n)$	(in ⁴)	44034	-	44034
S_s	(in ³)	966	2045	966
$S_c(n)$	(in ³)	1319	-	1319
$S_c(3n)$	(in ³)	1193	-	1193
DC1	(k/')	1.092	1.268	1.092
M _{DC1}	(k)	766	2446	960
DC2	(k/')	0.235	0.235	0.235
M _{DC2}	(k)	189	424	231
DW	(k/')	0.370	0.370	0.370
M _{DW}	(k)	298	668	364
M _{Σ + imp}	(k)	1790	1866	1902
M _u (Strength I)	(k)	4774	7855	5363
φ _r M _n , φ _r M _{nc}	(k)	7385	8520	7390
f _s DC1	(ksi)	9.5	14.4	11.9
f _s DC2	(ksi)	1.9	2.5	2.3
f _s DW	(ksi)	3.0	3.9	3.7
f _s 1.3(Σ + IMP)	(ksi)	21.2	14.2	22.5
f _s (Service II)	(ksi)	35.6	35.0	40.4
f _s (Total)(Strength I)	(ksi)	-	-	-
V _r	(k)	29.6	-	30.4

- I_s, S_s : Non-composite moment of inertia and section modulus of the steel section used for computing f_s (Total-Strength I, and Service II) due to non-composite dead loads (in.⁴ and in.³).
- $I_c(n), S_c(n)$: Composite moment of inertia and section modulus of the steel and deck based upon the modular ratio, "n", used for computing f_s (Total-Strength I, and Service II) due to short-term composite live loads (in.⁴ and in.³).
- $I_c(3n), S_c(3n)$: Composite moment of inertia and section modulus of the steel and deck based upon 3 times the modular ratio, "3n", used for computing f_s (Total-Strength I, and Service II) due to long-term composite (superimposed) dead loads (in.⁴ and in.³).
- DC1: Un-factored non-composite dead load (kips/ft.).
- M_{DC1}: Un-factored moment due to non-composite dead load (kip-ft.).
- DC2: Un-factored long-term composite (superimposed excluding future wearing surface) dead load (kips/ft.).
- M_{DC2}: Un-factored moment due to long-term composite (superimposed excluding future wearing surface) dead load (kip-ft.).
- DW: Un-factored long-term composite (superimposed future wearing surface only) dead load (kips/ft.).
- M_{DW}: Un-factored moment due to long-term composite (superimposed future wearing surface only) dead load (kip-ft.).
- M_{Σ + imp}: Un-factored live load moment plus dynamic load allowance (impact) (kip-ft.).
- M_u (Strength I): Factored design moment (kip-ft.).
1.25 (M_{DC1} + M_{DC2}) + 1.5 M_{DW} + 1.75 M_{Σ + imp}
- φ_rM_n: Compact composite positive moment capacity computed according to Article 6.10.7.1 (kip-ft.).
- φ_rM_{nc}: Compact non-composite negative moment capacity computed according to Article A6.1.1 (kip-ft.).
- f_s (Service II): Sum of stresses as computed from the moments below (ksi).
M_{DC1} + M_{DC2} + M_{DW} + 1.3 M_{Σ + imp}
- f_s (Total)(Strength I): Sum of stresses as computed from the moments below on non-compact section (ksi).
1.25 (M_{DC1} + M_{DC2}) + 1.5 M_{DW} + 1.75 M_{Σ + imp}
- V_r: Factored shear range computed according to Article 6.10.10.

Notes:
Anchor bolts shall be ASTM F1554 all-thread (or an Engineer-approved alternate material) of the grade(s) and diameter(s) specified. ASTM A307 Grade C anchor bolts may be used in lieu of ASTM F1554 Grade 36 (F_y=36ksi). The corresponding specified grade of AASHTO M314 anchor bolts may be used in lieu of ASTM F1554.
Anchor bolts at fixed bearings may be either cast in place or installed in holes drilled after the supported member is in place
Drilled and set anchor bolts shall be installed according to Article 521.06 of the Standard Specifications.
Two 1/8 in. adjusting shims shall be provided for each bearing in addition to all other plates or shims as shown on bearing details.
The structural steel plates and pintles of the Bearing Assembly shall conform to the requirements of AASHTO M270 Grade 50.

INTERIOR GIRDER REACTION TABLE			
HL93 Loading			
	Abutment		Pier
	Span 1	Span 2	
R _{DC1} (k)	42.7	47.2	174.6
R _{DC2} (k)	9.5	10.5	34.6
R _{DW} (k)	15.0	16.5	54.5
R _{Σ + imp} (k)	107.7	109.7	209.9
R _{Total} (k)	174.9	183.9	473.6

STRUCTURAL STEEL &
BEARING DETAILS
STRUCTURE NO. 025-0106

DESIGNED	A.C.S.
CHECKED	B.B.
DRAWN	W.J.S.
CHECKED	C.J.F.

BERNARDIN LOCHMUELLER & ASSOCIATES, INC.
3 Oak Drive
Morgantown, IL 62959-5685
Local (618) 288-4665
Fax 618-288-4666

SHEET NO. 29	F.A.I. RTE.	SECTION	COUNTY	TOTAL SHEETS	SHEET NO.
	57/70	(25-3HB-2)B	EFFINGHAM	839	358
38 SHEETS	SN 025-0106		CONTRACT NO. 74293		
FED. ROAD DIST. NO. 7 ILLINOIS FED. AID PROJECT					

STATE OF ILLINOIS
DEPARTMENT OF TRANSPORTATION

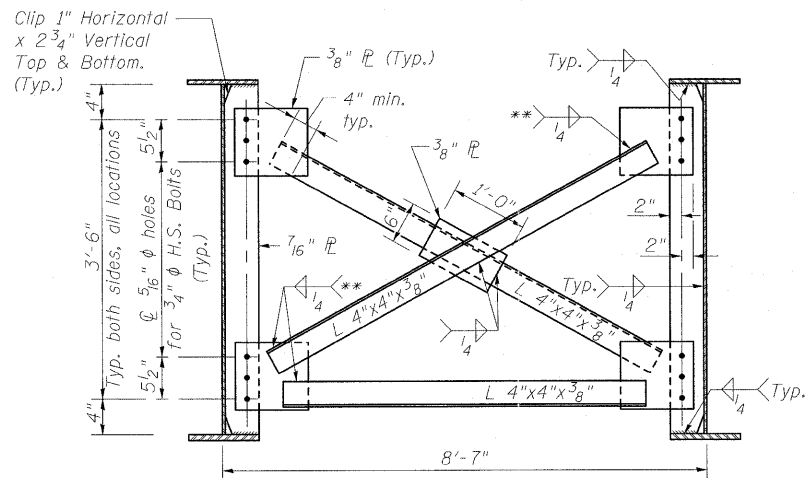

INTERIOR CROSSFRAME CF
(99 Required)

**Fillet weld angles along 3 sides on one face of gusset plate.

**TEMPORARY INTERIOR CROSSFRAME
INSTALLATION PROCEDURE**

1. Install Stage I temporary Interior Crossframe (CF*) before Stage I deck pour.
2. Remove Stage I temporary Interior Crossframe (CF*) prior to Stage II removal.
3. Install Stage II temporary Interior Crossframe (CF*) before Stage II deck pour.
4. Remove Stage II temporary Interior Crossframe (CF*) prior to Stage III closure pour.

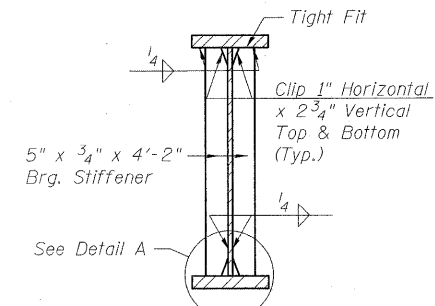

SECTION AT ABUT.

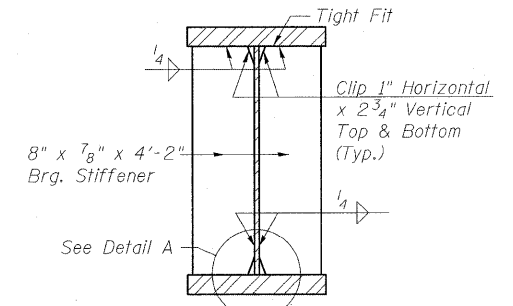

SECTION AT PIER

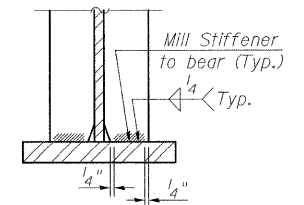

DETAIL A

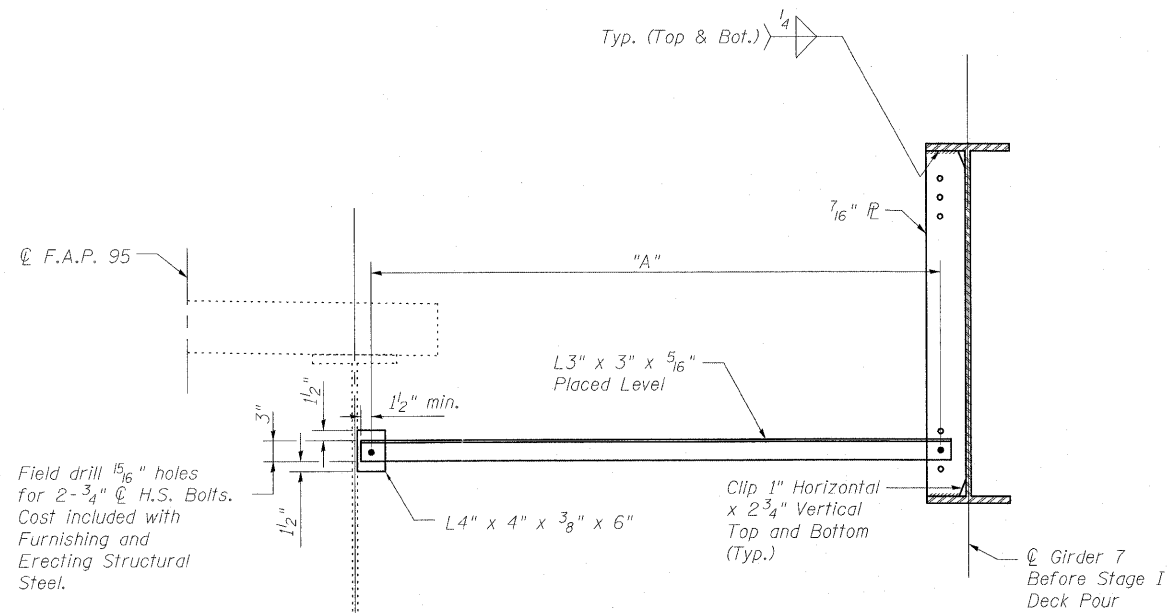

**STAGE I TEMPORARY
INTERIOR CROSSFRAME**
(10 Required)

Field drill 1 5/16" holes for 2-3/4" H.S. Bolts. Cost included with Furnishing and Erecting Structural Steel.

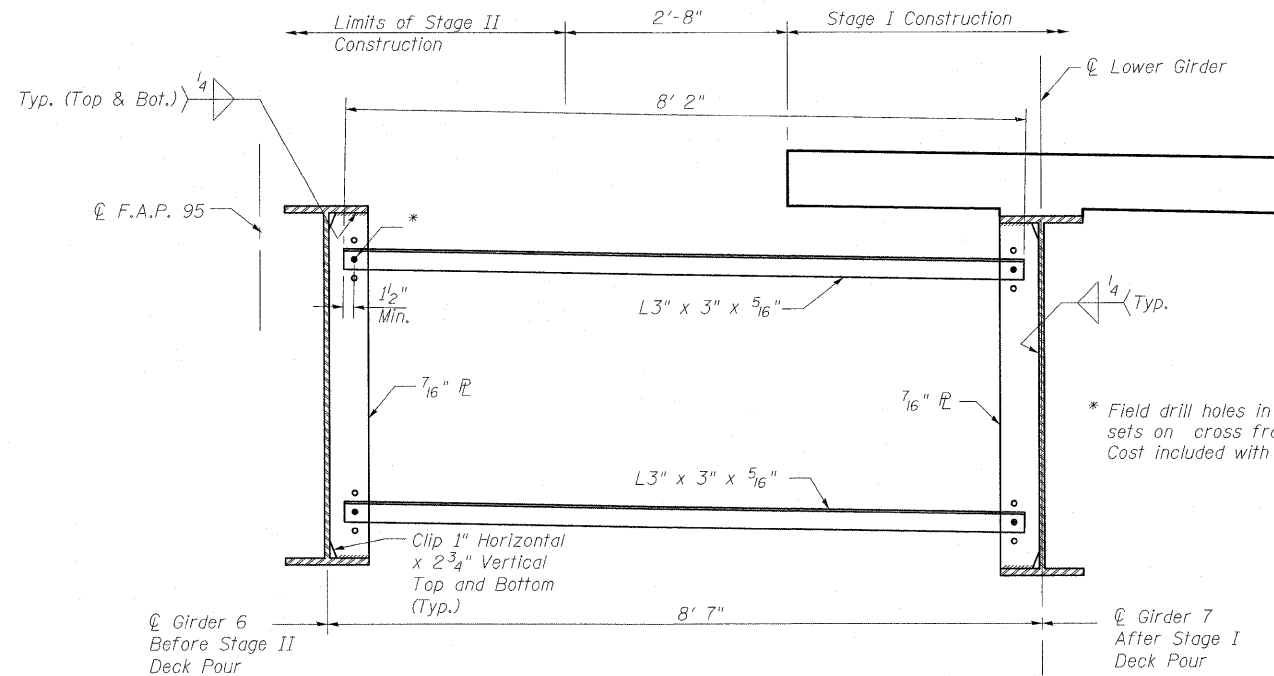

**STAGE II TEMPORARY
INTERIOR CROSSFRAME**
(10 Required)

* Field drill holes in L3"x3" angle using center holes in 3 hole sets on cross frame connection plates as a template. Cost included with Furnishing and Erecting Structural Steel.

Note:
Stop fillet weld from connection plate to flange 1/4" from end of connection plate.
Bolts connecting temporary bracing shall be 7/8" φ bolts in 1 1/16" φ holes. All other holes in connection plates shall be 1 5/16" φ for 3/4" φ bolts.
Cost of Stage I and Stage II Temporary Interior Crossframes included with Furnishing and Erecting Structural Steel.

DESIGNED	A.C.S.
CHECKED	B.B.
DRAWN	W.J.S.
CHECKED	C.J.F.

The horizontal dimension "A" between holes in the cross frame connection plate and L4"x4" angle shall be measured in the field. The holes in the L3"x3" angle shall be field drilled based on this dimension.

**STRUCTURAL STEEL
CROSS FRAMING DETAILS
STRUCTURE NO. 025-0106**



**BERNARDIN
LOCHMUELLER &
ASSOCIATES, INC.**

3 Oak Drive
Merrville, IL 60062-5635
Local (618) 288-4666
Fax 618-288-4666

SHEET NO. 29B 38 SHEETS	F.A.I. RTE. 57/70	SECTION (25-3HB-2)B	COUNTY EFFINGHAM	TOTAL SHEETS 839	SHEET NO. 358A
	SN 025-0106		CONTRACT NO. 74293		
FED. ROAD DIST. NO. 7 ILLINOIS FED. AID PROJECT					

STATE OF ILLINOIS
DEPARTMENT OF TRANSPORTATION

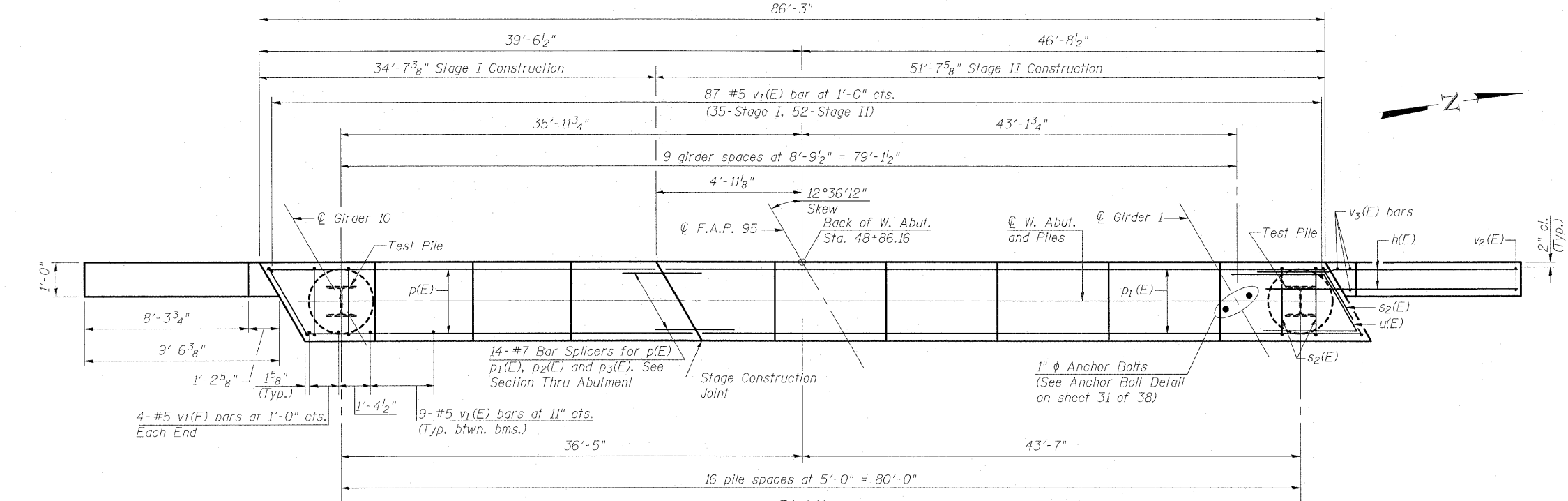
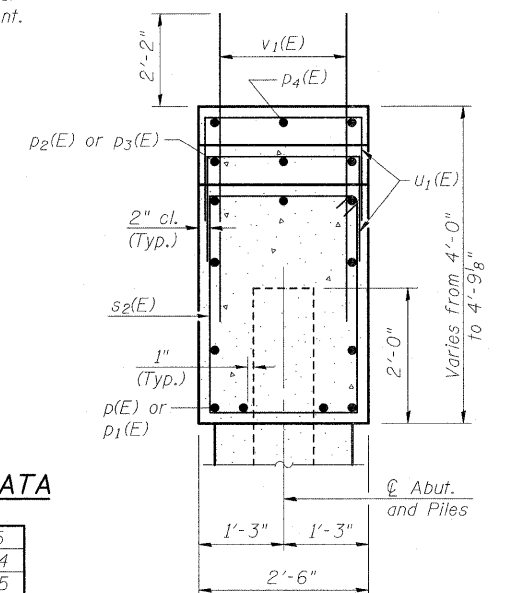
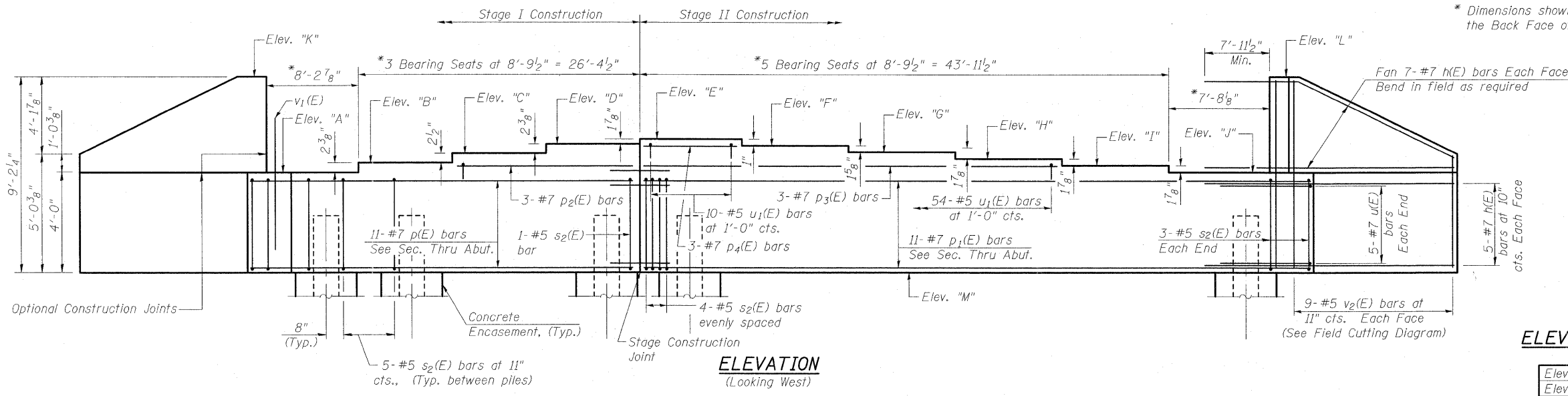

BILL OF MATERIAL

Bar	No.	Size	Length	Shape
h(E)	48	#7	18'-4"	—
p(E)	11	#7	34'-4"	—
p1(E)	11	#7	51'-4"	—
p2(E)	3	#7	17'-10"	—
p3(E)	3	#7	34'-10"	—
p4(E)	3	#7	8'-6"	—
s2(E)	89	#5	12'-7"	□
u(E)	8	#7	8'-9"	┘
u1(E)	64	#5	5'-0"	┘
v1(E)	176	#5	4'-4"	—
v2(E)	18	#5	13'-7"	—
v3(E)	6	#5	8'-11"	—
Structure Excavation		Cu. Yd.	318	
Concrete Structures		Cu. Yd.	40.4	
Reinforcement Bars, Epoxy Coated		Pound	6860	
Furnishing Steel Piles, HP 12x63		Foot	525	
Driving Piles		Foot	525	
Test Pile Steel HP 12x63		Each	2	
Concrete Encasement		Cu. Yd.	6	
Pile Shoes		Each	15	
Bar Splicers		Each	14	

PILE DATA

Type: HP 12x63 with Pile Shoes
Nominal Required Bearing: 497 k
Factored Resistance Available: 249 k
Est. Length: 35'-0"
No. Production Piles: 15
No. Test Piles: 2

Notes:
Pour steps monolithically with cap. See sheet 2 of 38 for section thru Integral Abutment showing drainage details.
For detail of piles and concrete Encasements see sheet 33 of 38. Space reinforcement in cap to miss anchor bolts.
See sheet 31 of 38 for Anchor Bolt Detail. Order p2(E), p3(E) and p4(E) bars full length and cut to fit.
Stage Construction Joint for Abutment does not align with Stage I or Stage II Construction Joints.

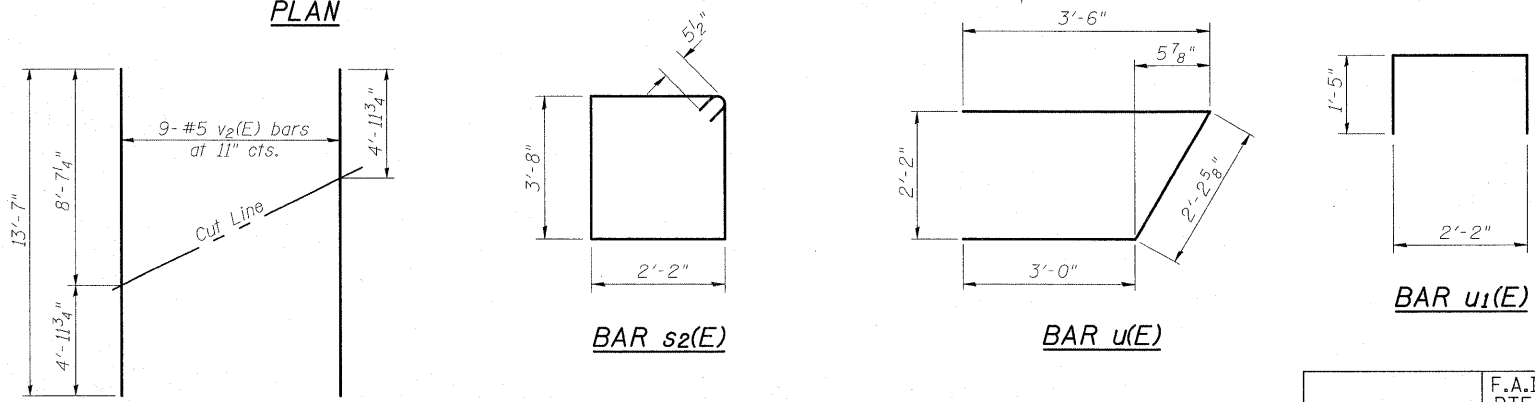

DESIGNED	A.C.S.
CHECKED	B.B.
DRAWN	W.J.S.
CHECKED	C.J.F.

FIELD CUTTING DIAGRAM

Order v2(E) full length. Cut as shown and use remainder of bars in opposite face.

BERNARDIN LOCHMUELLER & ASSOCIATES, INC.
3 Oak Drive
Maryville, IL 62452-9655
Local: (618) 338-4666
Fax: 618-288-4666

SHEET NO. 30 38 SHEETS	F.A.I. RTE.	SECTION	COUNTY	TOTAL SHEETS	SHEET NO.
	57/70	(25-3HB-2)B	EFFINGHAM	839	359
SN 025-0106			CONTRACT NO. 74293		
FED. ROAD DIST. NO. 7 ILLINOIS FED. AID PROJECT					

**WEST ABUTMENT DETAILS
STRUCTURE NO. 025-0106**

For details of Bar Splicers, see sheet 34 of 38.

STATE OF ILLINOIS
DEPARTMENT OF TRANSPORTATION

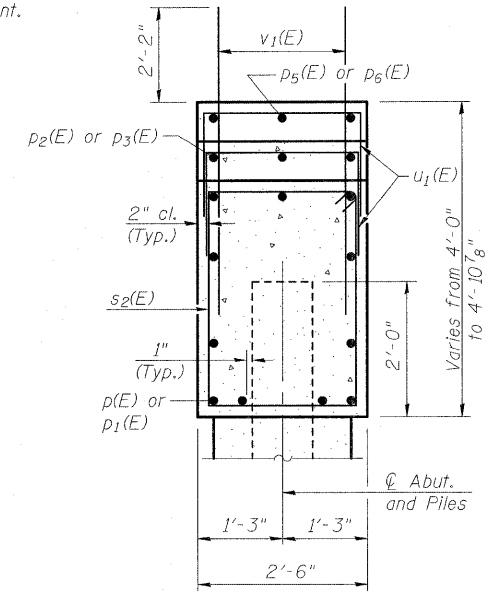
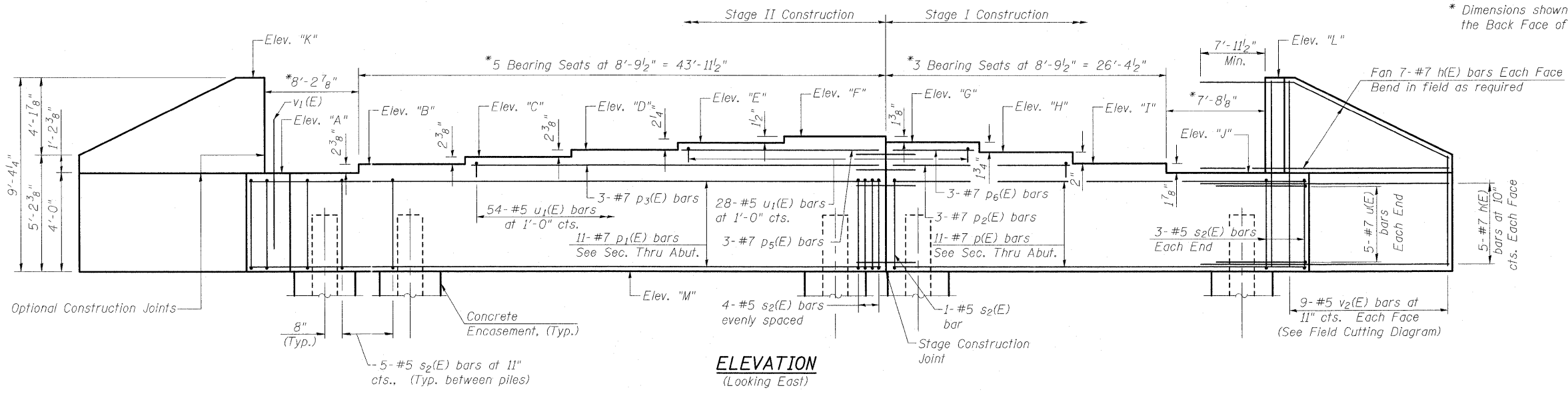

SEC. THRU ABUT.

BILL OF MATERIAL

Bar	No.	Size	Length	Shape
h(E)	48	#7	18'-4"	—
p(E)	11	#7	34'-4"	—
p ₁ (E)	11	#7	51'-4"	—
p ₂ (E)	3	#7	17'-10"	—
p ₃ (E)	3	#7	34'-10"	—
p ₅ (E)	3	#7	17'-4"	—
p ₆ (E)	3	#7	9'-1"	—
s ₂ (E)	89	#5	12'-7"	□
u(E)	8	#7	8'-9"	┘
u ₁ (E)	82	#5	5'-0"	□
v ₁ (E)	176	#5	4'-4"	—
v ₂ (E)	18	#5	13'-7"	—
v ₃ (E)	6	#5	8'-11"	—
Structure Excavation			Cu. Yd.	318
Concrete Structures			Cu. Yd.	41.4
Reinforcement Bars, Epoxy Coated			Pound	7060
Furnishing Steel Piles, HP 12x63			Foot	675
Driving Piles			Foot	675
Test Pile Steel HP 12x63			Each	2
Concrete Encasement			Cu. Yd.	6
Pile Shoes			Each	15
Bar Splicers			Each	17

For details of Bar Splicers, see sheet 34 of 38.

**EAST ABUTMENT DETAILS
STRUCTURE NO. 025-0106**

ELEVATION DATA

Elev. A	598.37
Elev. B	598.57
Elev. C	598.77
Elev. D	598.96
Elev. E	599.14
Elev. F	599.28
Elev. G	599.15
Elev. H	599.01
Elev. I	598.84
Elev. J	598.68
Elev. K	603.74
Elev. L	603.91
Elev. M	594.37

PLAN

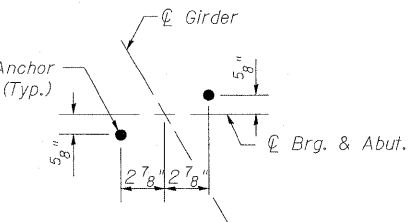
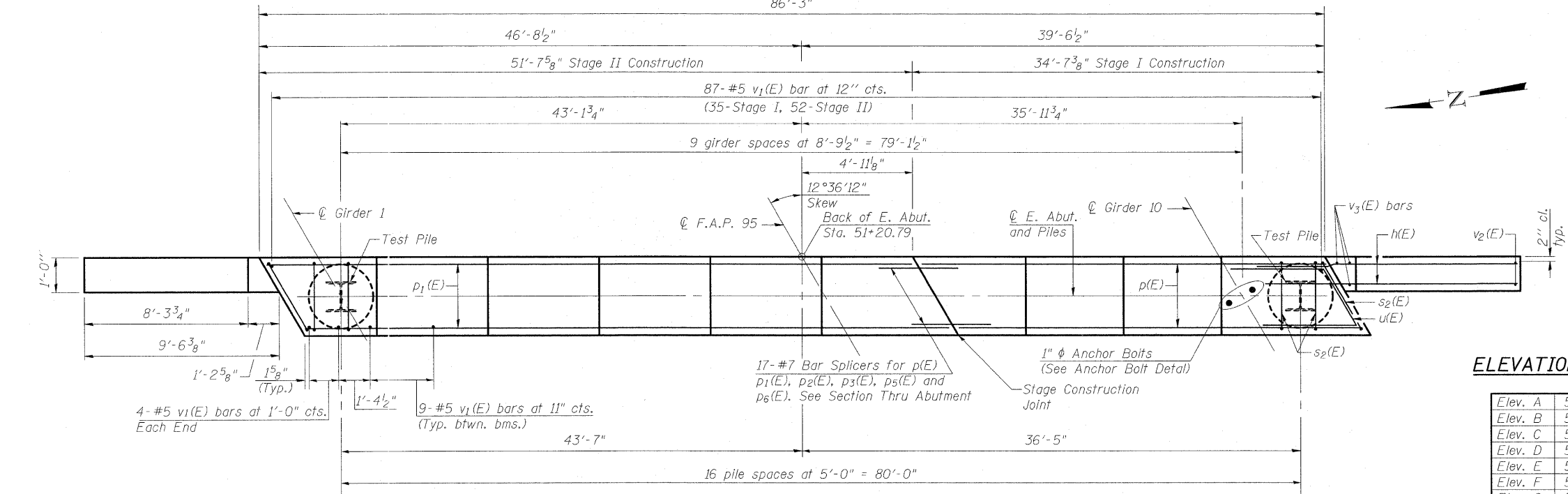

ANCHOR BOLT DETAIL

PILE DATA

Type: HP 12x63 with Pile Shoes
Nominal Required Bearing: 497 k
Factored Resistance Available: 249 k
Est. Length: 45'-0"
No. Production Piles: 15
No. Test Piles: 2

Notes:
Pour steps monolithically with cap.
See sheet 2 of 38 for section thru Integral Abutment showing drainage details.
For detail of piles and Concrete Encasements see sheet 33 of 38.
Space reinforcement in cap to miss anchor bolts.
For additional bar details see sheet 30 of 38.
For Bill of Materials see sheet 30 of 38.
For details of Bar Splicers, see sheet 34 of 38.
Order p₂(E), p₃(E), p₅(E) and p₆(E) bars full length and cut to fit.
Stage Construction Joint for Abutment does not align with Stage I or Stage II Construction Joints.

DESIGNED	A.C.S.
CHECKED	B.B.
DRAWN	W.J.S.
CHECKED	C.J.F.

BERNARDIN LOCHMUELLER & ASSOCIATES, INC.

3 Oak Drive
Marysville, IL 62452-5655
Local (618) 338-4666
Fax 618-288-4666

SHEET NO. 31	F.A.I. RTE.	SECTION	COUNTY	TOTAL SHEETS	SHEET NO.
38 SHEETS	57/70	(25-3HB-2)B	EFFINGHAM	839	360
SN 025-0106			CONTRACT NO. 74293		
FED. ROAD DIST. NO. 7 ILLINOIS FED. AID PROJECT					

STATE OF ILLINOIS
DEPARTMENT OF TRANSPORTATION

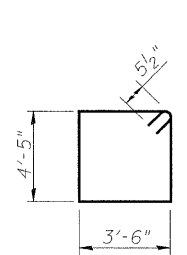

BAR $s_3(E)$

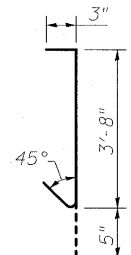

BAR $s_6(E)$ & $s_7(E)$

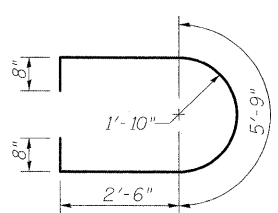

BAR $u_4(E)$

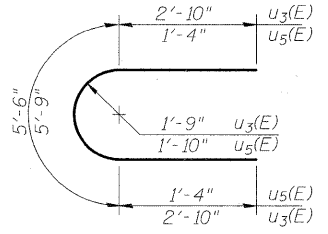

BARS $u_3(E)$ & $u_5(E)$

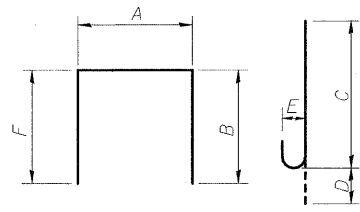

BARS

A, B, C, D, E & F DIMENSIONS

Bar	A	B	C	D	E	F
$n(E)$			6'-7"	11"	8"	
$n_1(E)$			7'-3"	1'-3"	11 $\frac{3}{4}$ "	
$n_2(E)$			7'-9"	1'-3"	11 $\frac{3}{4}$ "	
$p_7(E)$			29'-2"	1'-3"	11 $\frac{3}{4}$ "	
$p_8(E)$			50'-2"	1'-3"	11 $\frac{3}{4}$ "	
$s_4(E)$	3'-6"	3'-6"				3'-6"
$s_5(E)$	3'-8"	3'-0"				3'-6"
$u_2(E)$	3'-6"	1'-4"				1'-4"
$v_4(E)$			6'-2"	11"	8"	

BILL OF MATERIAL

Bar	No.	Size	Length	Shape
$h_1(E)$	6	#5	29'-2"	—
$h_2(E)$	6	#5	50'-2"	—
$h_3(E)$	8	#4	23'-4"	—
$h_4(E)$	8	#4	47'-4"	—
$h_5(E)$	18	#6	22'-8"	—
$h_6(E)$	18	#6	45'-8"	—
$n(E)$	120	#8	7'-6"	U
$n_1(E)$	154	#9	8'-6"	U
$n_2(E)$	154	#9	9'-0"	U
$p_7(E)$	22	#9	30'-5"	U
$p_8(E)$	22	#9	51'-5"	U
$p_9(E)$	5	#5	15'-7"	—
$p_{10}(E)$	5	#5	6'-10"	—
$p_{11}(E)$	5	#5	36'-7"	—
$p_{12}(E)$	5	#5	19'-0"	—
$p_{13}(E)$	5	#7	25'-0"	—
$p_{14}(E)$	5	#7	46'-0"	—
$p_{15}(E)$	10	#7	5'-10"	—
$s_3(E)$	71	#5	16'-9"	□
$s_4(E)$	36	#5	10'-6"	U
$s_5(E)$	142	#9	10'-2"	—
$s_6(E)$	76	#3	4'-4"	—
$s_7(E)$	460	#4	4'-4"	—
$sp(E)$	8	#5	12'-1"	W
$t_1(E)$	282	#7	9'-6"	—
$u_2(E)$	82	#5	6'-2"	U
$u_3(E)$	12	#5	11'-2"	—
$u_4(E)$	8	#4	12'-1"	—
$u_5(E)$	18	#6	8'-5"	—
$v_4(E)$	120	#8	7'-1"	U
$v_5(E)$	12	#9	3'-6"	—
$v_6(E)$	12	#9	3'-0"	—
$w_2(E)$	22	#5	26'-1"	—
$w_3(E)$	22	#5	50'-1"	—
Structure Excavation		Cu. Yd.	228	
Concrete Structures		Cu. Yd.	260.2	
Reinforcement Bars, Epoxy Coated		Pound	43705	
Furnishing Steel Piles, HP 12x63		Foot	884	
Driving Piles		Foot	884	
Test Pile, HP 12x63		Each	2	
Pile Shoes		Each	26	
Bar Splicers		Each	73	
Mechanical Splicers		Each	482	
Concrete Sealer		Sq. Ft.	2573	

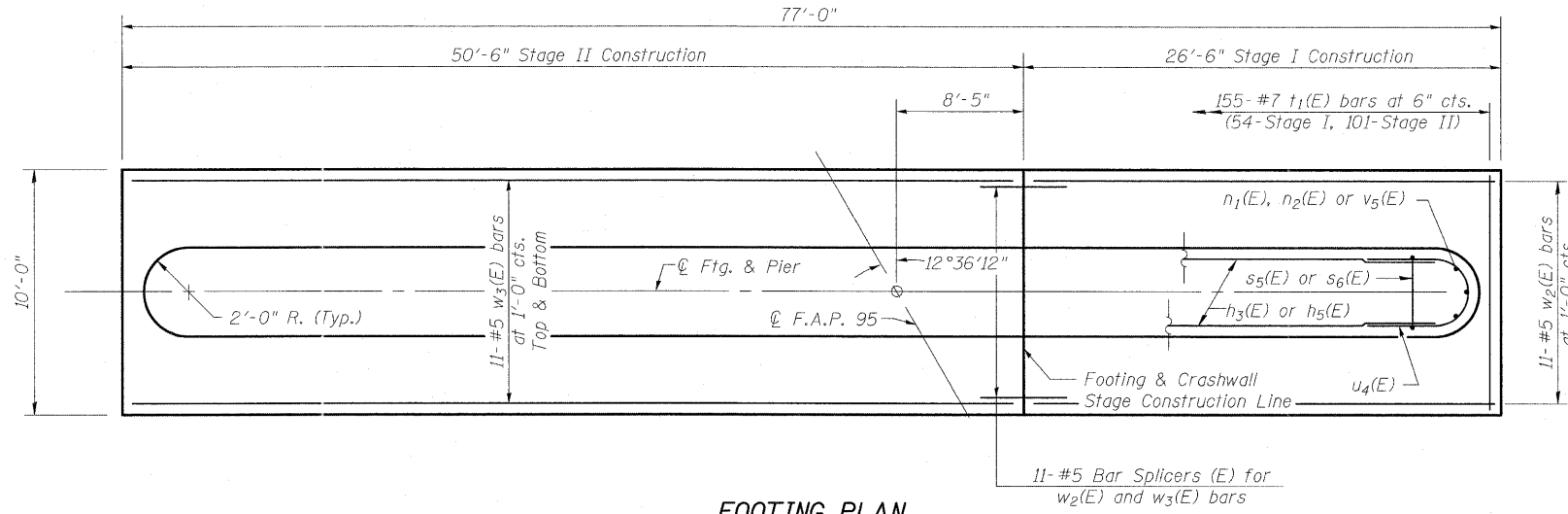

FOOTING PLAN
(Showing Top Reinforcement)

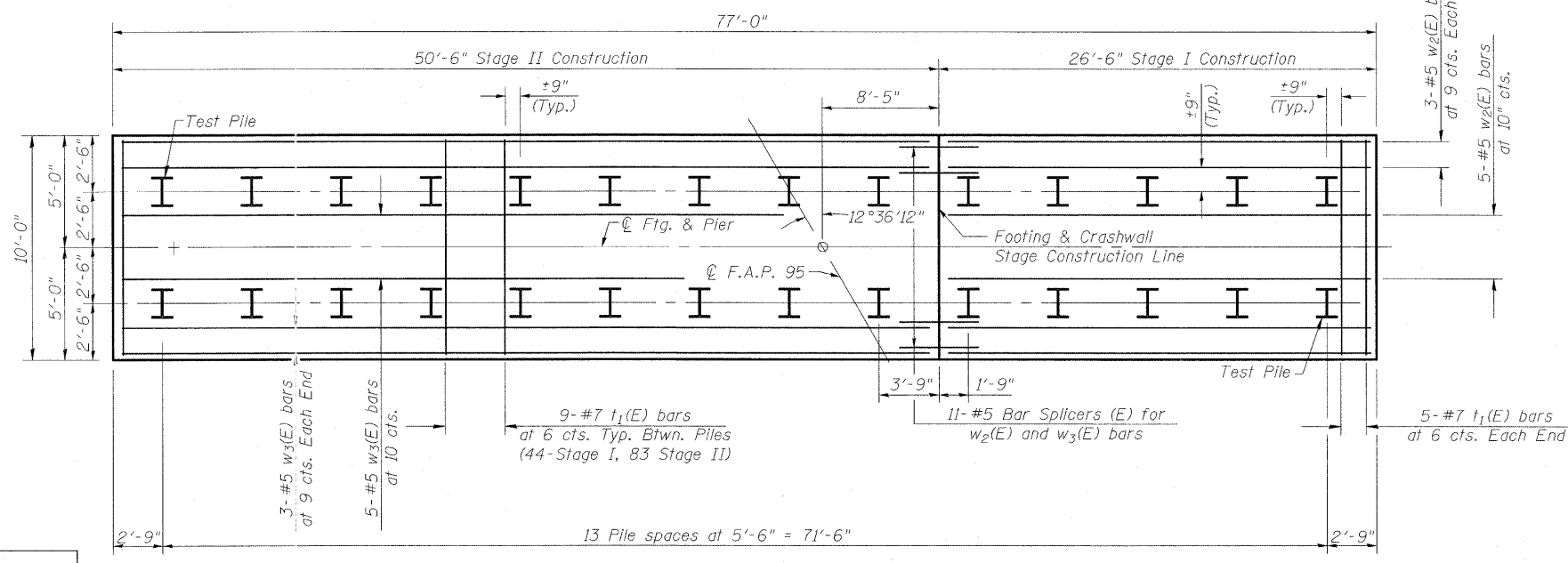

FOOTING PLAN
(Showing Bottom Reinforcement)

Notes:
Space $t_1(E)$, $w_2(E)$ and $w_3(E)$ bars to miss piles.
For details of piles see sheet 33 of 38.
For pile embedment into footing see End View on sheet 32 of 38.

PILE DATA

Type: HP 12x63 with Pile Shoes
Nominal Required Bearing: 497k
Factored Resistance Available: 249k
Est. Length: 34'-0"
No. Production Piles: 26
No. Test Piles: 2

PIER DETAILS
STRUCTURE NO. 025-0106

DESIGNED	A.C.S.
CHECKED	B.B.
DRAWN	W.J.S.
CHECKED	C.J.F.

BERNARDIN LOCHMUELLER & ASSOCIATES, INC.
3 Oak Drive
Mareville, IL 62862-5635
Local (618) 288-4695
Fax 618-288-4666

SHEET NO. 32B	F.A.I. RTE.	SECTION	COUNTY	TOTAL SHEETS	SHEET NO.
38 SHEETS	57/70	(25-3HB-2)B	EFFINGHAM	839	361
SN 025-0106			CONTRACT NO. 74293		
FED. ROAD DIST. NO. 7 ILLINOIS FED. AID PROJECT					

STATE OF ILLINOIS
DEPARTMENT OF TRANSPORTATION

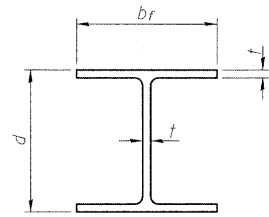

STEEL PILE TABLE

Designation	Depth d	Flange width bf	Web and Flange thickness t	Encasement diameter A
HP 14x117	14 1/4"	14 7/8"	13/16"	30"
x102	14"	14 3/4"	1/16"	30"
x89	13 7/8"	14 3/4"	5/8"	30"
x73	13 5/8"	14 5/8"	1/2"	30"
HP 12x84	12 1/4"	12 1/4"	1/16"	24"
x74	12 1/8"	12 1/4"	5/8"	24"
x63	12"	12 1/8"	1/2"	24"
x53	11 3/4"	12"	7/16"	24"
HP 10x57	10"	10 1/4"	9/16"	24"
x42	9 3/4"	10 1/8"	7/16"	24"
HP 8x36	8"	8 1/8"	7/16"	18"

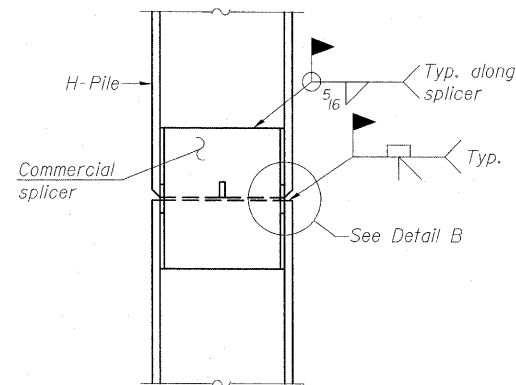

ELEVATION

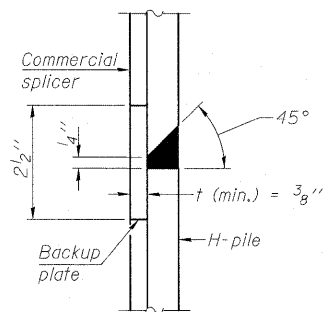

DETAIL "B"

WELDED COMMERCIAL SPLICE

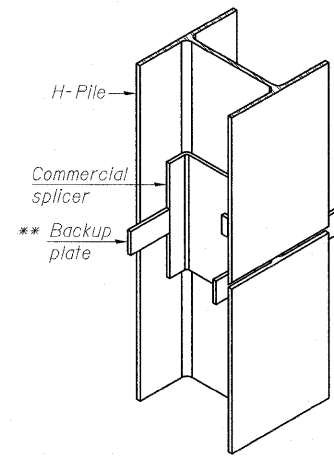

ISOMETRIC VIEW

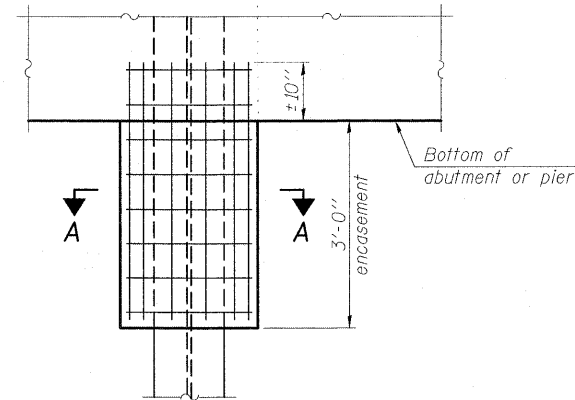

ELEVATION

PILE ENCASEMENT

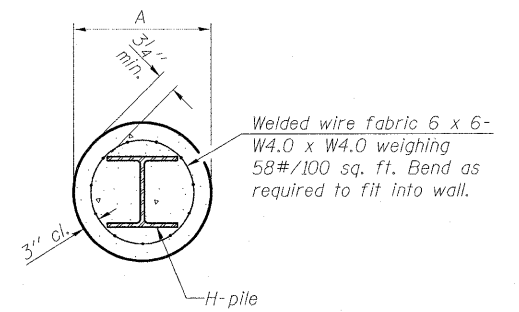

Note:
Forms for encasement may be omitted when soil conditions permit.

SECTION A-A

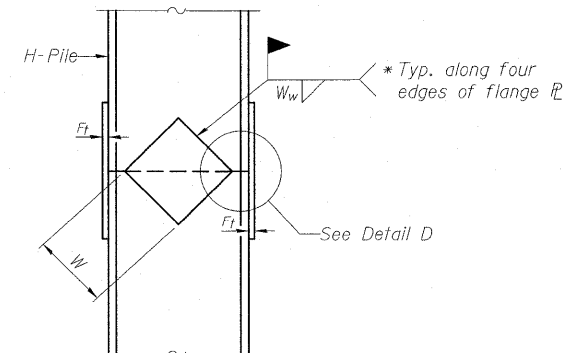

ELEVATION

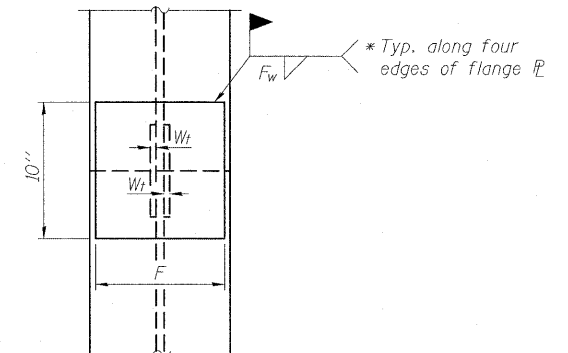

END VIEW

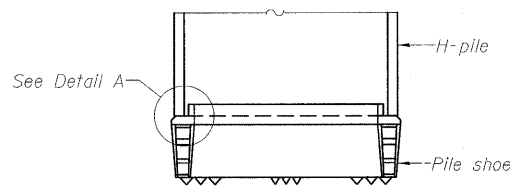

ELEVATION

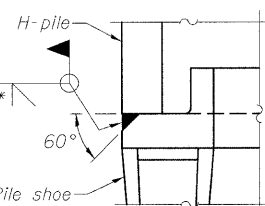

DETAIL A

H-PILE SHOE ATTACHMENT

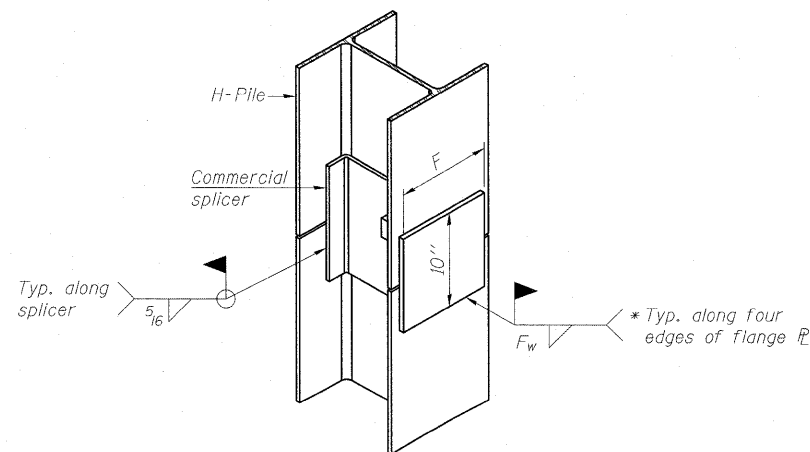

ISOMETRIC VIEW

WELDED COMMERCIAL SPLICE ALTERNATE

- * Interrupt welds 1/4" from end of web and/or each flange.
- ** Remove portions of backup plates that extend outside the flanges.
- *** Weld size per pile shoe manufacturer (5/16" min.).

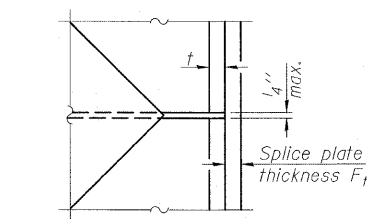

DETAIL D

WELDED PLATE FIELD SPLICE

Designation	F	Ft	Fw	W	Wt	Ww
HP 14x117	12 1/2"	1"	7/8"	7 3/4"	5/8"	1/2"
x102	12 1/2"	7/8"	3/4"	7 3/4"	5/8"	1/2"
x89	12 1/2"	3/4"	1/16"	7 3/4"	5/8"	1/2"
x73	12 1/2"	5/8"	9/16"	7 3/4"	5/8"	1/2"
HP 12x84	10"	7/8"	1/16"	6 1/2"	5/8"	1/2"
x74	10"	7/8"	1/16"	6 1/2"	5/8"	1/2"
x63	10"	5/8"	1/2"	6 1/2"	1/2"	3/8"
x53	10"	5/8"	1/2"	6 1/2"	1/2"	3/8"
HP 10x57	8"	3/4"	9/16"	5 1/4"	1/2"	3/8"
x42	8"	5/8"	9/16"	5 1/4"	1/2"	3/8"
HP 8x36	7"	5/8"	7/16"	4 1/4"	1/2"	3/8"

Note:
The steel H-piles shall be according to AASHTO M270 Grade 50.

HP PILE DETAILS
STRUCTURE NO. 025-0106

DESIGNED	
CHECKED	
DRAWN	W.J.S.
CHECKED	C.J.F.

F-HP 11-1-09



BERNARDIN
LOCHMUELLER &
ASSOCIATES, INC.

3 Oak Drive
Marengo, IL 62862-2685
Local (618) 288-4665
Fax 618-288-4666

SHEET NO. 33 38 SHEETS	F.A.I. RTE.	SECTION	COUNTY	TOTAL SHEETS	SHEET NO.
	57/70	(25-3HB-2)B	EFFINGHAM	839	362
SN 025-0106			CONTRACT NO. 74293		
FED. ROAD DIST. NO. 7 ILLINOIS FED. AID PROJECT					

STATE OF ILLINOIS
DEPARTMENT OF TRANSPORTATION

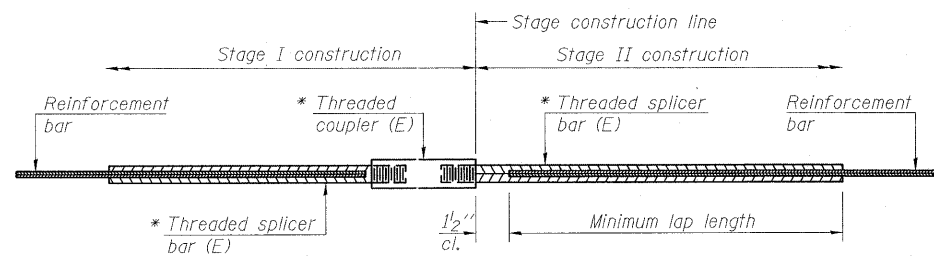

STANDARD BAR SPLICER ASSEMBLY

Bar size to be spliced	Minimum Lap Lengths			
	Table 1	Table 2	Table 3	Table 4
3, 4	1'-5"	1'-11"	2'-1"	2'-4"
5	1'-9"	2'-5"	2'-7"	2'-11"
6	2'-1"	2'-11"	3'-1"	3'-6"
7	2'-9"	3'-10"	4'-2"	4'-8"
8	3'-8"	5'-1"	5'-5"	6'-2"
9	4'-7"	6'-5"	6'-10"	7'-9"

Table 1: Black bar, 0.8 Class C
Table 2: Black bar, Top bar lap, 0.8 Class C
Table 3: Epoxy bar, 0.8 Class C
Table 4: Epoxy bar, Top bar lap, 0.8 Class C

Threaded splicer bar length = min. lap length + 1/2" + thread length

* Epoxy not required on Bar Splicer Assembly components used in conjunction with black bars.

Location	Bar size	No. assemblies required	Table for minimum lap length
Bridge Deck	#5	1784	2'-7"
Bridge Deck	#6	8	3'-1"
Approach Slabs	#4	50	2'-4"
Approach Slabs	#5	172	2'-7"
Abutment Diaphragms	#6	16	3'-6"
Abutment Caps	#7	31	4'-8"
Pier	#4	8	2'-1"
Pier	#5	16	2'-7"
Pier	#5	22	2'-11"
Pier	#7	5	2'-11"
Pier	#9	22	7'-9"

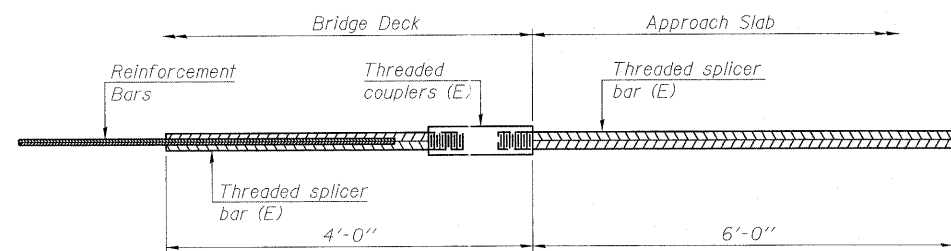

BAR SPLICER ASSEMBLY FOR #5 BAR ON INTEGRAL OR SEMI-INTEGRAL ABUTMENTS

No. required = 174

DESIGNED	
CHECKED	
DRAWN	W.J.S.
CHECKED	C.J.F.

BSD-1

11-1-09

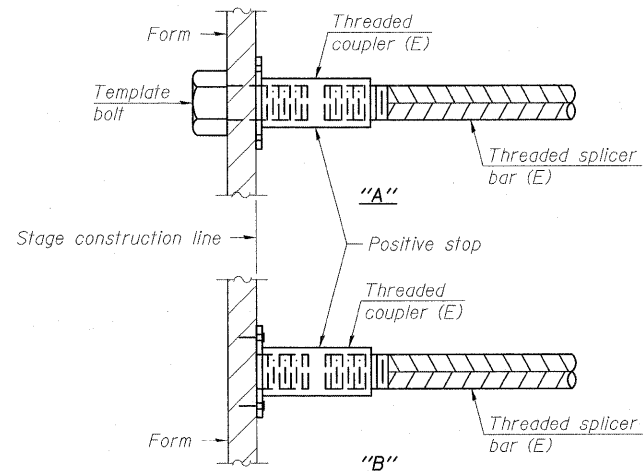

INSTALLATION AND SETTING METHODS

"A": Set bar splicer assembly by means of a template bolt.
"B": Set bar splicer assembly by nailing to wood forms or cementing to steel forms.
(E) : Indicates epoxy coating.

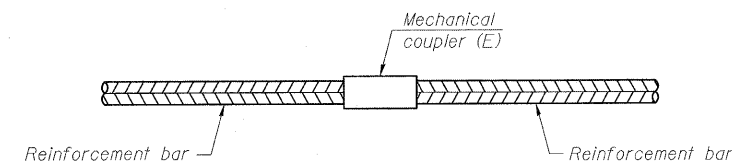

STANDARD MECHANICAL SPLICER

Location	Bar size	No. assemblies required
Pier	#6	54
Pier	#8	120
Pier	#9	308

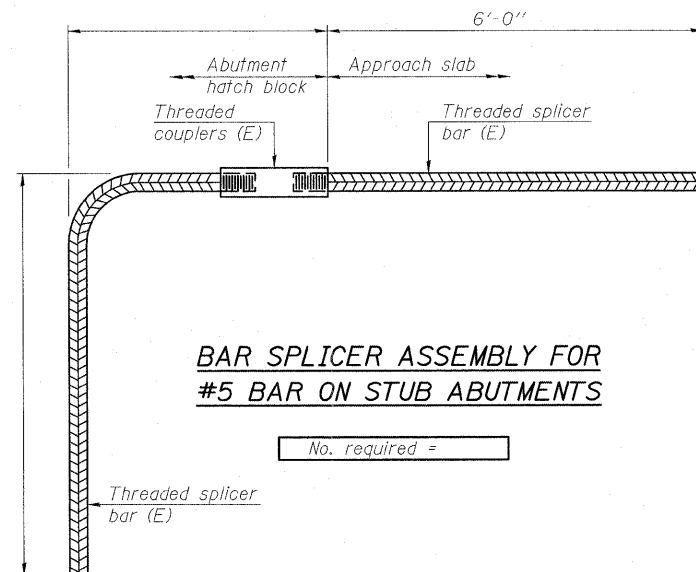

BAR SPLICER ASSEMBLY FOR #5 BAR ON STUB ABUTMENTS

No. required =

NOTES

Splicer bars shall be deformed with threaded ends and have a minimum 60 ksi yield strength.
All reinforcement shall be lapped and tied to the splicer bars.
Bar splicer assemblies shall be epoxy coated according to the requirements for reinforcement bars. See Section 508 of the Standard Specifications.
See special provision for Mechanical Splicers.
See approved list of bar splicer assemblies and mechanical splicers for alternatives.

**BAR SPLICER ASSEMBLY AND MECHANICAL SPLICER DETAILS
STRUCTURE NO. 025-0106**



**BERNARDIN
LOCHMUELLER &
ASSOCIATES, INC.**

3 Oak Drive
Maryville, IL 62062-5655
Local (618) 298-4665
Fax 618-298-4666

SHEET NO. 34 38 SHEETS	F.A.I. RTE. 57/70	SECTION (25-3HB-2)B	COUNTY EFFINGHAM	TOTAL SHEETS 839	SHEET NO. 363
	SN 025-0106		CONTRACT NO. 74293		
FED. ROAD DIST. NO. 7 ILLINOIS FED. AID PROJECT					

STATE OF ILLINOIS
DEPARTMENT OF TRANSPORTATION

Illinois Department of Transportation
Division of Highways
R2 Engineering, Inc.

SOIL BORING LOG

Page 1 of 2
Date 03/27/07

ROUTE FAI 5770 DESCRIPTION West Fayette over I-5770 LOGGED BY E. Sandachafer

SECTION (24-4.3)R LOCATION Sec 19 - S 12, Sec 30 - N 12, SEC., TWP. 8N, RNG. 6E

COUNTY Effingham DRILLING METHOD Hollow stem auger & split spoon HAMMER TYPE Auto 140#

STRUCT. NO. 025-0023
Station 50+00
BORING NO. B-1
Station 48+44
Offset 25.00 ft Lt
Ground Surface Elev. 600.74 ft

Soil Description	Depth (ft)	U	M	Strength
ASPHALT Shoulder	0			
Stiff, damp, red, CLAY TILL	0-3			
	3-4			
	4-6			
	6-8			
	8-10			
	10-12			
	12-14			
	14-16			
	16-18			
	18-20			
	20-22			
	22-24			
	24-26			
	26-28			
	28-30			
	30-32			
	32-34			
	34-36			

The Unconfined Compressive Strength (UCS) Failure Mode is indicated by (B-Bulge, S-Shear, P-Penetrometer)
AASHTO Classifications are based on visual classifications unless otherwise noted BBS, form 137 (Rev. 8-99)

Illinois Department of Transportation
Division of Highways
R2 Engineering, Inc.

SOIL BORING LOG

Page 2 of 2
Date 03/27/07

ROUTE FAI 5770 DESCRIPTION West Fayette over I-5770 LOGGED BY E. Sandachafer

SECTION (24-4.3)R LOCATION Sec 19 - S 12, Sec 30 - N 12, SEC., TWP. 8N, RNG. 6E

COUNTY Effingham DRILLING METHOD Hollow stem auger & split spoon HAMMER TYPE Auto 140#

STRUCT. NO. 025-0023
Station 50+00
BORING NO. B-1
Station 48+44
Offset 25.00 ft Lt
Ground Surface Elev. 600.74 ft

Soil Description	Depth (ft)	U	M	Strength
Hard, very moist, gray SANDY CLAY TILL (continued)	0-5			
	5-8			
	8-10			
	10-12			
	12-14			
	14-16			
	16-18			
	18-20			
	20-22			
	22-24			
	24-26			
	26-28			
	28-30			
	30-32			
	32-34			
	34-36			

The Unconfined Compressive Strength (UCS) Failure Mode is indicated by (B-Bulge, S-Shear, P-Penetrometer)
AASHTO Classifications are based on visual classifications unless otherwise noted BBS, form 137 (Rev. 8-99)

Illinois Department of Transportation
Division of Highways
R2 Engineering, Inc.

ROCK CORE LOG

Page 1 of 1
Date 03/27/07

ROUTE FAI 5770 DESCRIPTION West Fayette over I-5770 LOGGED BY E. Sandachafer

SECTION (24-4.3)R LOCATION Sec 19 - S 12, Sec 30 - N 12, SEC., TWP. 8N, RNG. 6E

COUNTY Effingham CORING METHOD Rotary, surf set diamond bit

STRUCT. NO. 025-0023
Station 50+00
BORING NO. B-1
Station 48+44
Offset 25.00 ft Lt
Ground Surface Elev. 600.74 ft

Rock Description	Depth (ft)	U	M	Strength
Gray, moderately weathered, CLAY SHALE	0-12			
	12-17			
	17-19			
	19-25			
	25-30			
	30-32			
	32-34			
	34-36			
	36-40			

Extent of exploration.
Benchmark: BM 506 Chiseled square on east pier crash wall under West Fayette Ave structure (025-0023) on NB I-57/E 170 Sta 2146+48, 66.5' Rt = elev. 583.44'. Provided by Program Development.
Boring terminated at 80.3 ft.

Color pictures of the cores Available upon request
Cores will be stored for examination until 03/27/08
The "Strength" column represents the uniaxial compressive strength of the core sample (ASTM D-2938)

BBS, form 138 (Rev. 8-99)

DESIGNED -
CHECKED -
DRAWN W.J.S.
CHECKED C.J.F.

BORING LOGS
STRUCTURE NO. 025-0106



3 Oak Drive
Maryville, IL 62052-5635
Local (618) 288-4665
Fax 618-288-4666

SHEET NO. 35	F.A.I. RTE. 57/70	SECTION (25-3HB-2)B	COUNTY EFFINGHAM	TOTAL SHEETS 839	SHEET NO. 364
38 SHEETS	SN 025-0106		CONTRACT NO. 74293		
FED. ROAD DIST. NO. 7		ILLINOIS		FED. AID PROJECT	

03:50:34 AM 8/12/2000 N:\0250106\106\106-35.dgn

STATE OF ILLINOIS
DEPARTMENT OF TRANSPORTATION

Illinois Department of Transportation
Division of Highways
SCI Engineering, Inc.

SOIL BORING LOG Page 1 of 2
Date 04/30/07

ROUTE FAI 5770 DESCRIPTION West Fayette over I-5770 LOGGED BY E. Sandtschafer

SECTION (24-4.3)R LOCATION Sec 19 - S 12, Sec 30 - N 12, SEC. TWP. 8N, R1G. 6E

COUNTY Effingham DRILLING METHOD Hollow stem auger & split spoon HAMMER TYPE Auto 140#

STRUCT. NO. 025-0023
Station 50+00

BORING NO. B-2
Station 49+10
Offset 41.00 ft Rt
Ground Surface Elev. 581.23 ft

DEPTH (ft)	DESCRIPTION	TESTS	UCS (psi)	MOISTURE (%)	CLASSIFICATION
0	Augered through asphalt shoulder.				
3	Stiff, damp, red marbled gray, SANDY CLAY	1.3 B			
7					
11					
22	Hard, very moist, gray, LOAM TILL				
22		0.4 S			
28	Gray, fine grained, SAND - 13% passing #200 sieve.				
25	Hard, damp, brown marbled gray, CLAY LOAM TILL	4.1 B			
32	Brown, fine grained, SAND - 6% passing #200 sieve.				
28					
15	Hard, damp, brown marbled gray, CLAY LOAM TILL	8.4 BS			
29					
50					
28	Hard, very moist, brown and gray layered SANDY CLAY TILL	4.2 S			
48					
50					
27	Hard, very moist, gray, CLAY LOAM TILL	8.4 BS			
32					
43					
16		8.2 S			
26					
33					
29	Dark brown, SILTY LOAM				

The Unconfined Compressive Strength (UCS) Failure Mode is indicated by (B-Bulge, S-Shear, P-Penetrometer)
AASHTO Classifications are based on visual classifications unless otherwise noted. BBS, form 137 (Rev. 8-99)

Illinois Department of Transportation
Division of Highways
SCI Engineering, Inc.

SOIL BORING LOG Page 2 of 2
Date 04/30/07

ROUTE FAI 5770 DESCRIPTION West Fayette over I-5770 LOGGED BY E. Sandtschafer

SECTION (24-4.3)R LOCATION Sec 19 - S 12, Sec 30 - N 12, SEC. TWP. 8N, R1G. 6E

COUNTY Effingham DRILLING METHOD Hollow stem auger & split spoon HAMMER TYPE Auto 140#

STRUCT. NO. 025-0023
Station 50+00

BORING NO. B-2
Station 49+10
Offset 41.00 ft Rt
Ground Surface Elev. 581.23 ft

DEPTH (ft)	DESCRIPTION	TESTS	UCS (psi)	MOISTURE (%)	CLASSIFICATION
12	Very stiff, damp, gray, SILTY CLAY TILL (continued)	3.5 B			
15					
4		2.6 B			
7					
9					
13	Very stiff, damp, bluish-gray, SANDY LOAM TILL	2.3 S			
21					
44					
50	Very dense, moist, gray, LIMESTONE				

Benchmark: EM 506 Chiseled square on east pier crash wall under West Fayette Ave structure (025-0023) on NB I-5770 Sta 2146+48, 66.5' Rt = elev. 583.44'. Provided by Program Development.

B2 I-5770 Station = 2145+77, Lt 81'
Boring terminated at 60.1 ft.

The Unconfined Compressive Strength (UCS) Failure Mode is indicated by (B-Bulge, S-Shear, P-Penetrometer)
AASHTO Classifications are based on visual classifications unless otherwise noted. BBS, form 137 (Rev. 8-99)

Illinois Department of Transportation
Division of Highways
SCI Engineering, Inc.

SOIL BORING LOG Page 1 of 2
Date 05/25/07

ROUTE FAI 5770 DESCRIPTION West Fayette over I-5770 LOGGED BY E. Sandtschafer

SECTION (24-4.3)R LOCATION Sec 19 - S 12, Sec 30 - N 12, SEC. TWP. 8N, R1G. 6E

COUNTY Effingham DRILLING METHOD Hollow stem auger & split spoon HAMMER TYPE Auto 140#

STRUCT. NO. 025-0023
Station 50+00

BORING NO. B-3
Station 50+08
Offset 42.00 ft Lt
Ground Surface Elev. 577.29 ft

DEPTH (ft)	DESCRIPTION	TESTS	UCS (psi)	MOISTURE (%)	CLASSIFICATION
17	Hard, very moist, gray, CLAY LOAM TILL (continued)	5.5 B			
18					
8	Soft, wet, brown, SANDY LOAM				
6		0.3 B			
4					
10	Gray, fine grained, SAND				
20	Hard, very moist, gray, CLAY LOAM TILL	6.5 S			
35					
15	Very stiff, very moist, gray, SANDY CLAY TILL	3.4 S			
36	Brown, very fine grained, SAND				
1	Very stiff, very moist, gray, SANDY CLAY TILL	2.9 S			
44					
13	Hard, very moist, gray, CLAY LOAM TILL	6.6 S			
25					
43					
23		4.8 S			
45					
50					
14		5.1 S			
25					
26					
9					

The Unconfined Compressive Strength (UCS) Failure Mode is indicated by (B-Bulge, S-Shear, P-Penetrometer)
AASHTO Classifications are based on visual classifications unless otherwise noted. BBS, form 137 (Rev. 8-99)

DESIGNED _____
CHECKED _____
DRAWN W.J.S.
CHECKED C.J.F.



**BERNARDIN
LOCHMUELLER &
ASSOCIATES, INC.**

3 Oak Drive
Maryville, IL 62442-5635
Local (618) 388-4665
Fax 618-288-4666

SHEET NO. 36	F.A.I. RTE. 57/70	SECTION (25-3HB-2)B	COUNTY EFFINGHAM	TOTAL SHEETS 839	SHEET NO. 365
38 SHEETS	SN 025-0106		CONTRACT NO. 74293		
FED. ROAD DIST. NO. 7 ILLINOIS FED. AID PROJECT					

**BORING LOGS
STRUCTURE NO. 025-0106**

STATE OF ILLINOIS
DEPARTMENT OF TRANSPORTATION

Illinois Department of Transportation
Division of Highways
S&I Engineering, Inc.

SOIL BORING LOG

Page 2 of 2
Date 05/25/07

ROUTE FAI 5770 DESCRIPTION West Fayette over I-5770 LOGGED BY E. Sandschafer

SECTION (24-4.3)R LOCATION Sec 19 - S 12, Sec 30 - N 12, SEC., TWP. 8N, RNG. 6E

COUNTY Effingham DRILLING METHOD Hollow stem auger & split spoon HAMMER TYPE Auto 140#

STRUCT. NO. 025-0023
Station 50+00

BORING NO. B-3
Station 50+08
Offset 42.00 ft
Ground Surface Elev. 577.29 ft

Depth (ft)	D	B	U	M	Surface Water Elev.	Stream Bed Elev.	Groundwater Elev.
10			3.7	18	NA ft	NA ft	
26			S				
37.79							
533.04							
44				9			
502"							
501"							
50							
55							
60							

Very dense, moist, brown marbled gray, CLAY SHALE

Very dense, moist, dark brown, SILTY CLAY SHALE. Unable to drill to next interval, too hard.

Benchmark: EM 506 Chiseled square on east pier crash wall under West Fayette Ave structure (025-0023) on NB I-5770 Sta 2146+48, 66.5' Rt = elev. 583.44'. Provided by Program Development.

B3 I-5770 Station = 2146+74, Lt
Boring terminated at 44.25 ft.

The Unconfined Compressive Strength (UCS) Failure Mode is indicated by (B-Bulge, S-Shear, P-Penetrometer)
AASHTO Classifications are based on visual classifications unless otherwise noted BBS, form 137 (Rev. 8-99)

Illinois Department of Transportation
Division of Highways
S&I Engineering, Inc.

SOIL BORING LOG

Page 1 of 2
Date 04/20/07

ROUTE FAI 5770 DESCRIPTION West Fayette over I-5770 LOGGED BY E. Sandschafer

SECTION (24-4.3)R LOCATION Sec 19 - S 12, Sec 30 - N 12, SEC., TWP. 8N, RNG. 6E

COUNTY Effingham DRILLING METHOD Hollow stem auger & split spoon HAMMER TYPE Auto 140#

STRUCT. NO. 025-0023
Station 50+00

BORING NO. B-4
Station 50+51
Offset 38.00 ft
Ground Surface Elev. 581.57 ft

Depth (ft)	D	B	U	M	Surface Water Elev.	Stream Bed Elev.	Groundwater Elev.
16					NA ft	NA ft	
33							
4							
20							
24							
6							
7							
7							
41							
39							
37							
20							
25							
34							
17							
34							
504"							
34							
30							
30							
10							
17							
22							
8							

Augered through asphalt shoulder.

No recovery this trip, rock stuck in sampler shoe.

Medium to stiff, damp, red mottled gray, SANDY CLAY

Very stiff, damp, brown, SANDY CLAY TILL

Brown, SAND

Hard, very moist, brown and gray layered, CLAY LOAM TILL

Hard, very moist, gray, SANDY LOAM TILL

Very stiff, very moist, gray, CLAY LOAM TILL

Very stiff, very moist, gray, CLAY LOAM TILL (continued)

The Unconfined Compressive Strength (UCS) Failure Mode is indicated by (B-Bulge, S-Shear, P-Penetrometer)
AASHTO Classifications are based on visual classifications unless otherwise noted BBS, form 137 (Rev. 8-99)

Illinois Department of Transportation
Division of Highways
S&I Engineering, Inc.

SOIL BORING LOG

Page 2 of 2
Date 04/20/07

ROUTE FAI 5770 DESCRIPTION West Fayette over I-5770 LOGGED BY E. Sandschafer

SECTION (24-4.3)R LOCATION Sec 19 - S 12, Sec 30 - N 12, SEC., TWP. 8N, RNG. 6E

COUNTY Effingham DRILLING METHOD Hollow stem auger & split spoon HAMMER TYPE Auto 140#

STRUCT. NO. 025-0023
Station 50+00

BORING NO. B-4
Station 50+51
Offset 38.00 ft
Ground Surface Elev. 581.57 ft

Depth (ft)	D	B	U	M	Surface Water Elev.	Stream Bed Elev.	Groundwater Elev.
9					NA ft	NA ft	
12							
8							
14							
18							
6							
13							
18							
9							
13							
17							
9							
13							
17							
10							
17							
22							
8							

Very stiff, very moist, gray, CLAY LOAM TILL (continued)

Extent of exploration.

Benchmark: EM 506 Chiseled square on east pier crash wall under West Fayette Ave structure (025-0023) on NB I-5770 Sta 2146+48, 66.5' Rt = elev. 583.44'. Provided by Program Development.

B4 I-5770 Station = 2146+77, Rt
Boring terminated at 59.5 ft.

LIMESTONE

The Unconfined Compressive Strength (UCS) Failure Mode is indicated by (B-Bulge, S-Shear, P-Penetrometer)
AASHTO Classifications are based on visual classifications unless otherwise noted BBS, form 137 (Rev. 8-99)

DESIGNED	-
CHECKED	-
DRAWN	W.J.S.
CHECKED	C.J.F.



**BERNARDIN
LOCHMUELLER &
ASSOCIATES, INC.**

3 Oak Drive
Maryville, IL 63052-6635
Local-(618) 288-4665
Fax 618-288-4666

SHEET NO. 37 38 SHEETS	F.A.I. RTE.	SECTION	COUNTY	TOTAL SHEETS	SHEET NO.
	57/70	(25-3HB-2)B	EFFINGHAM	839	366
SN 025-0106			CONTRACT NO. 74293		
FED. ROAD DIST. NO. 7 ILLINOIS FED. AID PROJECT					

**BORING LOGS
STRUCTURE NO. 025-0106**

STATE OF ILLINOIS
DEPARTMENT OF TRANSPORTATION

Illinois Department of Transportation
Division of Highways
SCT Engineering, Inc.

SOIL BORING LOG Page 1 of 2
Date 03/23/07

ROUTE FAI 5770 DESCRIPTION West Fayette over I-5770 LOGGED BY E. Sandchafer

SECTION (24-4.3)R LOCATION Sec 19 - S 12, Sec 30 - N 12, SEC., TWP. 8N, RNG. 6E

COUNTY Effingham DRILLING METHOD Hollow stem auger & split spoon HAMMER TYPE Auto 140#

STRUCT. NO. 025-0023
Station 50+00

BORING NO. B-5
Station 51+46
Offset 25.00 ft LL
Ground Surface Elev. 601.75 ft

DEPTH (ft)	SOIL DESCRIPTION	DR	BR	UCS	TSF	PERCENT	DEPTH (ft)	DR	BR	UCS	TSF	PERCENT
0	ASPHALT shoulder						0					
0.3	Very soft, very damp, gray, SILTY CLAY LOAM (continued)	1	0.3	25			0.3					
1.2	Very soft, very damp, gray, SILTY CLAY LOAM (continued)	2	1.2	25			1.2					
2.1	Very soft, very damp, gray, SILTY CLAY LOAM (continued)	3	2.1	25			2.1					
3.0	Brown marbled gray, CLAY TILL	3	3.0	30			3.0					
4.6	Medium to stiff, damp, red marbled blue, CLAY LOAM TILL	4	4.6	18			4.6					
5.5	Hard, damp, brown marbled red, SANDY CLAY TILL	4	5.5	11			5.5					
10.9	Very stiff, very moist, red marbled gray, SANDY CLAY LOAM TILL	10	10.9	9			10.9					
19.0	Very stiff, very moist, red marbled gray, SANDY CLAY LOAM TILL	19	19.0	9			19.0					
28.0	Very stiff, very moist, gray mottled red, SANDY CLAY TILL	27	28.0	10			28.0					
38.0	Medium to stiff, damp, gray, SILTY CLAY w/ fine gravel	38	38.0	21			38.0					
48.0	Very dark brown, wet, PEAT	48	48.0	14			48.0					

The Unconfined Compressive Strength (UCS) Failure Mode is indicated by (B-D)ulge, S-Shear, P-Penetrometer
AASHTO Classifications are based on visual classifications unless otherwise noted: BBS, form 137 (Rev. 8-99)

Illinois Department of Transportation
Division of Highways
SCT Engineering, Inc.

SOIL BORING LOG Page 2 of 2
Date 03/23/07

ROUTE FAI 5770 DESCRIPTION West Fayette over I-5770 LOGGED BY E. Sandchafer

SECTION (24-4.3)R LOCATION Sec 19 - S 12, Sec 30 - N 12, SEC., TWP. 8N, RNG. 6E

COUNTY Effingham DRILLING METHOD Hollow stem auger & split spoon HAMMER TYPE Auto 140#

STRUCT. NO. 025-0023
Station 50+00

BORING NO. B-5
Station 51+46
Offset 25.00 ft LL
Ground Surface Elev. 601.75 ft

DEPTH (ft)	SOIL DESCRIPTION	DR	BR	UCS	TSF	PERCENT	DEPTH (ft)	DR	BR	UCS	TSF	PERCENT
4.6	Hard, very moist, gray, CLAY LOAM TILL (continued)	4	4.6	13			4.6					
11.0	Very stiff, very moist, gray, SANDY CLAY TILL	11	11.0	11			11.0					
16.0	Very stiff, very moist, dark gray, SILTY CLAY SHALE, pockerchipped	16	16.0	16			16.0					
27.0	Very stiff, very moist, gray, SANDY CLAY TILL	27	27.0	11			27.0					
36.0	Very stiff, very moist, gray, SANDY CLAY TILL	36	36.0	11			36.0					
46.0	Very stiff, very moist, gray, SANDY CLAY TILL	46	46.0	11			46.0					
56.0	Very stiff, very moist, gray, SANDY CLAY TILL	56	56.0	9			56.0					
66.0	Very stiff, very moist, gray, SANDY CLAY TILL	66	66.0	9			66.0					
76.0	Very stiff, very moist, gray, SANDY CLAY TILL	76	76.0	9			76.0					
86.0	Very stiff, very moist, gray, SANDY CLAY TILL	86	86.0	9			86.0					
96.0	Very stiff, very moist, gray, SANDY CLAY TILL	96	96.0	9			96.0					
106.0	Very stiff, very moist, gray, SANDY CLAY TILL	106	106.0	9			106.0					
116.0	Very stiff, very moist, gray, SANDY CLAY TILL	116	116.0	9			116.0					
126.0	Very stiff, very moist, gray, SANDY CLAY TILL	126	126.0	9			126.0					
136.0	Very stiff, very moist, gray, SANDY CLAY TILL	136	136.0	9			136.0					
146.0	Very stiff, very moist, gray, SANDY CLAY TILL	146	146.0	9			146.0					
156.0	Very stiff, very moist, gray, SANDY CLAY TILL	156	156.0	9			156.0					
166.0	Very stiff, very moist, gray, SANDY CLAY TILL	166	166.0	9			166.0					
176.0	Very stiff, very moist, gray, SANDY CLAY TILL	176	176.0	9			176.0					
186.0	Very stiff, very moist, gray, SANDY CLAY TILL	186	186.0	9			186.0					
196.0	Very stiff, very moist, gray, SANDY CLAY TILL	196	196.0	9			196.0					
206.0	Very stiff, very moist, gray, SANDY CLAY TILL	206	206.0	9			206.0					
216.0	Very stiff, very moist, gray, SANDY CLAY TILL	216	216.0	9			216.0					
226.0	Very stiff, very moist, gray, SANDY CLAY TILL	226	226.0	9			226.0					
236.0	Very stiff, very moist, gray, SANDY CLAY TILL	236	236.0	9			236.0					
246.0	Very stiff, very moist, gray, SANDY CLAY TILL	246	246.0	9			246.0					
256.0	Very stiff, very moist, gray, SANDY CLAY TILL	256	256.0	9			256.0					
266.0	Very stiff, very moist, gray, SANDY CLAY TILL	266	266.0	9			266.0					
276.0	Very stiff, very moist, gray, SANDY CLAY TILL	276	276.0	9			276.0					
286.0	Very stiff, very moist, gray, SANDY CLAY TILL	286	286.0	9			286.0					
296.0	Very stiff, very moist, gray, SANDY CLAY TILL	296	296.0	9			296.0					
306.0	Very stiff, very moist, gray, SANDY CLAY TILL	306	306.0	9			306.0					
316.0	Very stiff, very moist, gray, SANDY CLAY TILL	316	316.0	9			316.0					
326.0	Very stiff, very moist, gray, SANDY CLAY TILL	326	326.0	9			326.0					
336.0	Very stiff, very moist, gray, SANDY CLAY TILL	336	336.0	9			336.0					
346.0	Very stiff, very moist, gray, SANDY CLAY TILL	346	346.0	9			346.0					
356.0	Very stiff, very moist, gray, SANDY CLAY TILL	356	356.0	9			356.0					
366.0	Very stiff, very moist, gray, SANDY CLAY TILL	366	366.0	9			366.0					
376.0	Very stiff, very moist, gray, SANDY CLAY TILL	376	376.0	9			376.0					
386.0	Very stiff, very moist, gray, SANDY CLAY TILL	386	386.0	9			386.0					
396.0	Very stiff, very moist, gray, SANDY CLAY TILL	396	396.0	9			396.0					
406.0	Very stiff, very moist, gray, SANDY CLAY TILL	406	406.0	9			406.0					
416.0	Very stiff, very moist, gray, SANDY CLAY TILL	416	416.0	9			416.0					
426.0	Very stiff, very moist, gray, SANDY CLAY TILL	426	426.0	9			426.0					
436.0	Very stiff, very moist, gray, SANDY CLAY TILL	436	436.0	9			436.0					
446.0	Very stiff, very moist, gray, SANDY CLAY TILL	446	446.0	9			446.0					
456.0	Very stiff, very moist, gray, SANDY CLAY TILL	456	456.0	9			456.0					
466.0	Very stiff, very moist, gray, SANDY CLAY TILL	466	466.0	9			466.0					
476.0	Very stiff, very moist, gray, SANDY CLAY TILL	476	476.0	9			476.0					
486.0	Very stiff, very moist, gray, SANDY CLAY TILL	486	486.0	9			486.0					
496.0	Very stiff, very moist, gray, SANDY CLAY TILL	496	496.0	9			496.0					
506.0	Very stiff, very moist, gray, SANDY CLAY TILL	506	506.0	9			506.0					
516.0	Very stiff, very moist, gray, SANDY CLAY TILL	516	516.0	9			516.0					
526.0	Very stiff, very moist, gray, SANDY CLAY TILL	526	526.0	9			526.0					
536.0	Very stiff, very moist, gray, SANDY CLAY TILL	536	536.0	9			536.0					
546.0	Very stiff, very moist, gray, SANDY CLAY TILL	546	546.0	9			546.0					
556.0	Very stiff, very moist, gray, SANDY CLAY TILL	556	556.0	9			556.0					
566.0	Very stiff, very moist, gray, SANDY CLAY TILL	566	566.0	9			566.0					
576.0	Very stiff, very moist, gray, SANDY CLAY TILL	576	576.0	9			576.0					
586.0	Very stiff, very moist, gray, SANDY CLAY TILL	586	586.0	9			586.0					
596.0	Very stiff, very moist, gray, SANDY CLAY TILL	596	596.0	9			596.0					
606.0	Very stiff, very moist, gray, SANDY CLAY TILL	606	606.0	9			606.0					

The Unconfined Compressive Strength (UCS) Failure Mode is indicated by (B-D)ulge, S-Shear, P-Penetrometer
AASHTO Classifications are based on visual classifications unless otherwise noted: BBS, form 137 (Rev. 8-99)

Illinois Department of Transportation
Division of Highways
SCT Engineering, Inc.

ROCK CORE LOG Page 1 of 1
Date 03/23/07

ROUTE FAI 5770 DESCRIPTION West Fayette over I-5770 LOGGED BY E. Sandchafer

SECTION (24-4.3)R LOCATION Sec 19 - S 12, Sec 30 - N 12, SEC., TWP. 8N, RNG. 6E

COUNTY Effingham CORING METHOD Rotary, surf set diamond bit

STRUCT. NO. 025-0023
Station 50+00

BORING NO. B-5
Station 51+46
Offset 25.00 ft LL
Ground Surface Elev. 601.75 ft

DEPTH (ft)	SOIL DESCRIPTION	DR	BR	UCS	TSF	PERCENT	DEPTH (ft)	DR	BR	UCS	TSF	PERCENT
12.0	Hard, cemented, SANDSTONE	12	12.0	13			12.0					
19.0	Rock Core BSA @ 80.0' to 80.6' depth Qu = 1208 tsf	19	19.0	13			19.0					
517.2	Soft, cemented, SANDSTONE	517.2	517.2	11			517.2					
517.2	Gray, moderately weathered, CLAY SHALE	517.2	517.2	11			517.2					
512.2	Rock Core BSB @ 89.0' to 89.5' depth Qu = 15 tsf	512.2	512.2	16			512.2					

Extent of exploration

Benchmark: BM 506 Chiseled square on east pier crash wall under West Fayette Ave structure (025-0023) on NB I-5770 Sta 2146+46, 66.5' R = elev. 583.44'. Provided by Program Development.
Boring terminated at 60.5 ft.

Color pictures of the cores Available upon request
Cores will be stored for examination until 03/23/08
The "Strength" column represents the uniaxial compressive strength of the core sample (ASTM D-2938)

BBS, form 138 (Rev. 8-99)

DESIGNED _____
CHECKED _____
DRAWN W.J.S.
CHECKED C.J.F.

BORING LOGS
STRUCTURE NO. 025-0106

BERNARDIN LOCHMUELLER & ASSOCIATES, INC.
3 Oak Drive
Maryville, IL 62442-5635
Local (618) 398-4665
Fax 618-298-4666

SHEET NO. 38	F.A.I. RTE.	SECTION	COUNTY	TOTAL SHEETS	SHEET NO.
38 SHEETS	57/70	(25-3HB-2)B	EFFINGHAM	839	367
		SN 025-0106	CONTRACT NO. 74293		
FED. ROAD DIST. NO. 7 ILLINOIS FED. AID PROJECT					

10.318 AM 8/12/2000 _0250106_01_01_38.dgn

NO.	AREAS CHECKED
ORIGINAL SURVEY	PLOTTED
NOTE BOOK	TEMPLATE
NO.	AREAS CHECKED
BY	DATE

NO.	AREAS CHECKED
ORIGINAL SURVEY	PLOTTED
NOTE BOOK	TEMPLATE
NO.	AREAS CHECKED
BY	DATE

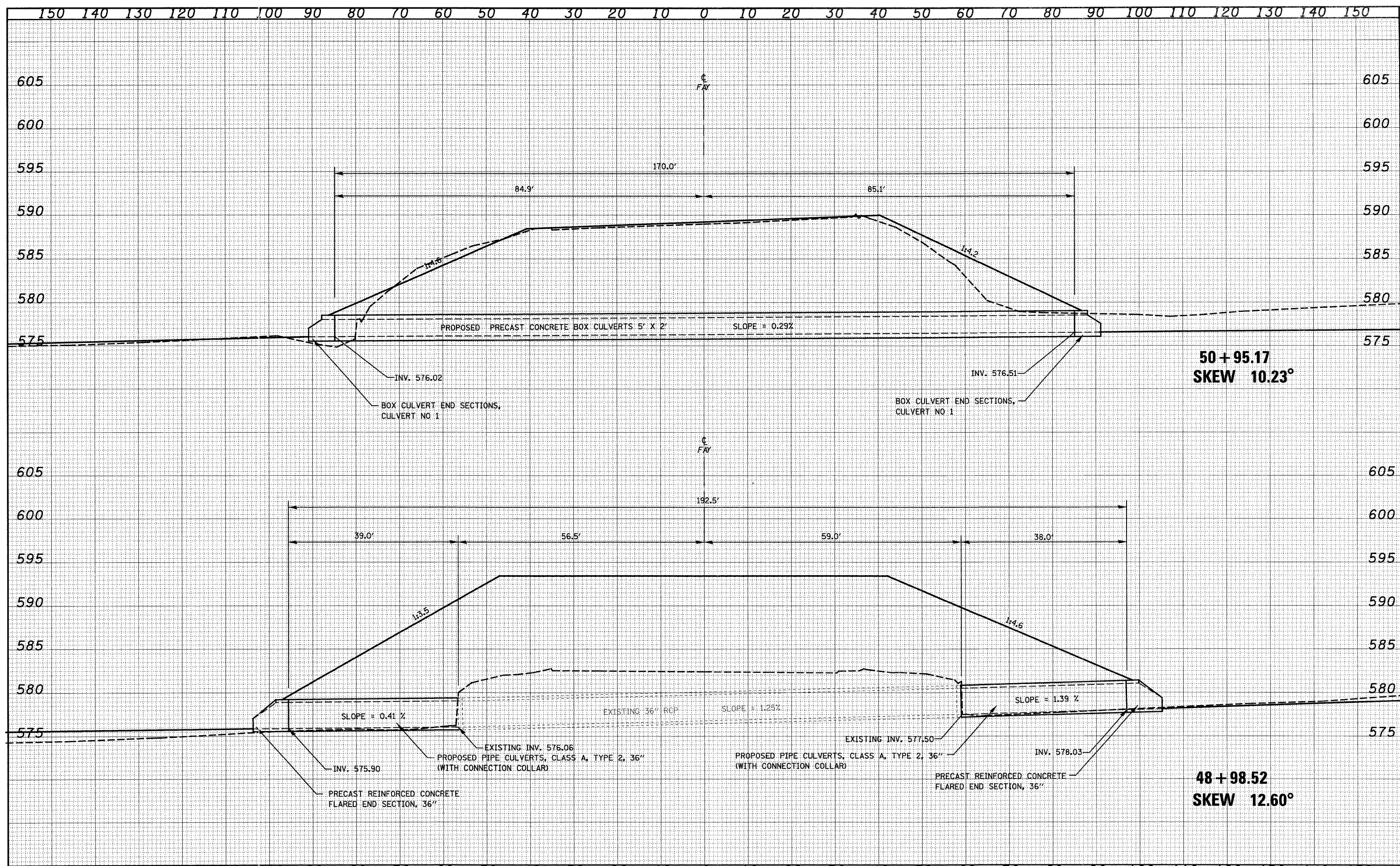

**50 + 95.17
SKEW 10.23°**

**48 + 98.52
SKEW 12.60°**

FILE NAME = S:\Projects\403-00072_57-70\dgn\Fayette	USER NAME = paul	DESIGNED - JWS	REVISED -	STATE OF ILLINOIS DEPARTMENT OF TRANSPORTATION	CULVERT PROFILES, FAYETTE AVENUE STA 48+98.52 TO STA 50+94.15		F.A.I. RTE. 57/70	SECTION (25-3)I-6	COUNTY EFFINGHAM	TOTAL SHEETS 839	SHEET NO. 368	
PLOT SCALE = 20,0000' / IN.	PLOT DATE = 6/24/2010	DRAWN - PDB	REVISED -		SCALE: 1"=10'	SHEET NO. 1 OF 2 SHEETS	STA. 48+98.52 TO STA. 50+94.15	CONTRACT NO. 74293				
		CHECKED - BRM	REVISED -		FED. ROAD DIST. NO. ILLINOIS FED. AID PROJECT							
		DATE - 11-05-07	REVISED -									

FINAL SURVEY	DATE
SURVEYED	BY
PLOTTED	
NOTE BOOK	
NO.	
AREAS CHECKED	

ORIGINAL SURVEY	DATE
SURVEYED	BY
PLOTTED	
NOTE BOOK	
NO.	
AREAS CHECKED	

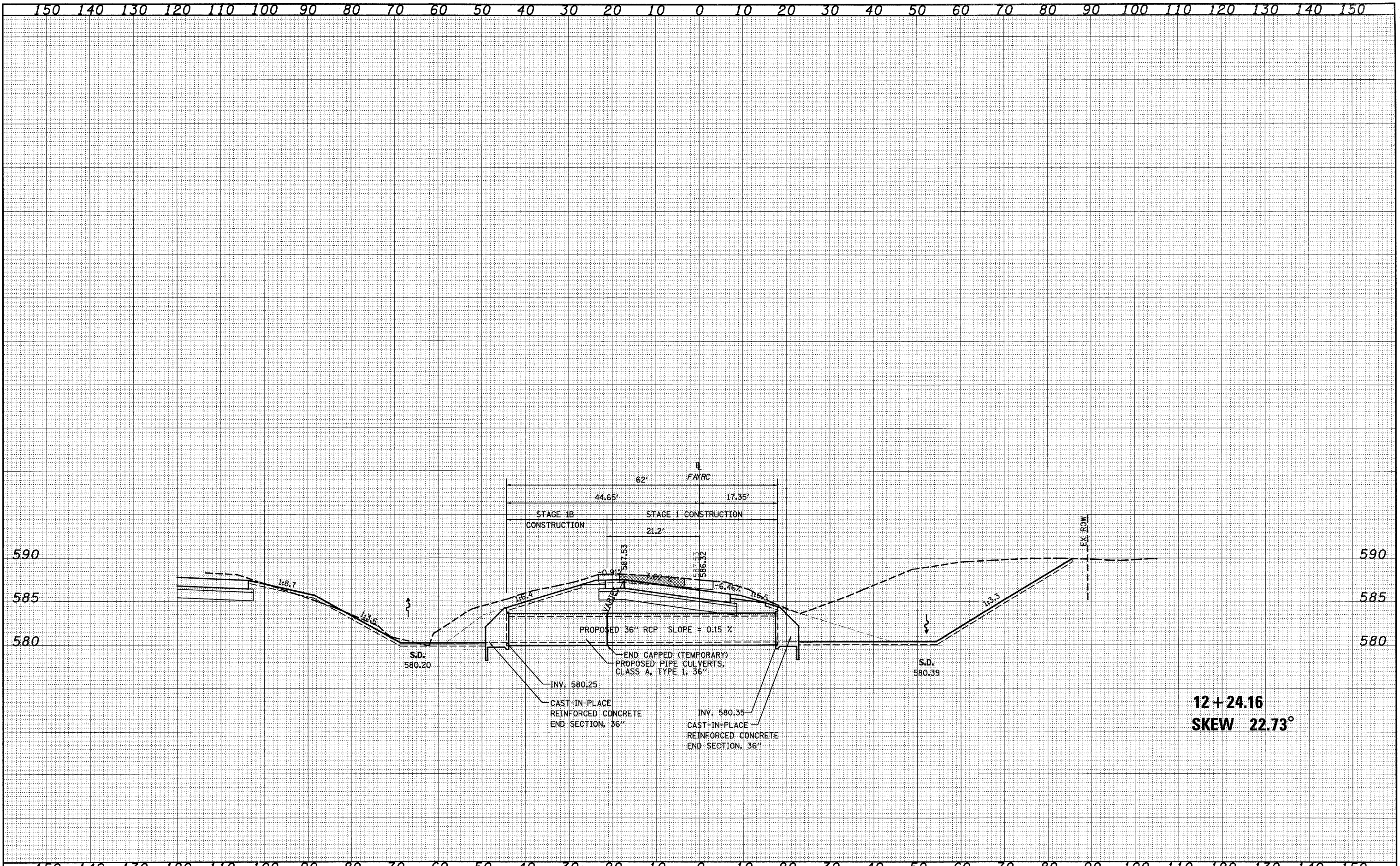

12 + 24.16
SKREW 22.73°

FILE NAME =	USER NAME = paul	DESIGNED - JWS	REVISED -	STATE OF ILLINOIS DEPARTMENT OF TRANSPORTATION	CULVERT PROFILES, FAYETTE AVENUE RAMP C, STA 12+24.16			F.A. RTE. 57/70	SECTION (25-3)I-6	COUNTY EFFINGHAM	TOTAL SHEETS 839	SHEET NO. 369
S:\Project\403-0007-57-70.dwg\Fayette\work\culvert\prof\89C.dwg	PLOT SCALE = 20.0000' / IN.	DRAWN - LEC	REVISED -		SCALE: 1"=10'	SHEET NO. 2 OF 2 SHEETS	STA. 12+24.16 TO STA. 12+24.16	CONTRACT NO. 74293		ILLINOIS FED. AID PROJECT		
	PLOT DATE = 6/24/2018	CHECKED - BRM	REVISED -									
		DATE - 11-05-07	REVISED -									

DATE	
BY	
SURVEYED	
PLOTTED	
TEMPLATE	
NOTE BOOK	
AREAS	
AREAS CHECKED	
NO.	

DATE	
BY	
SURVEYED	
PLOTTED	
TEMPLATE	
NOTE BOOK	
AREAS	
AREAS CHECKED	
NO.	

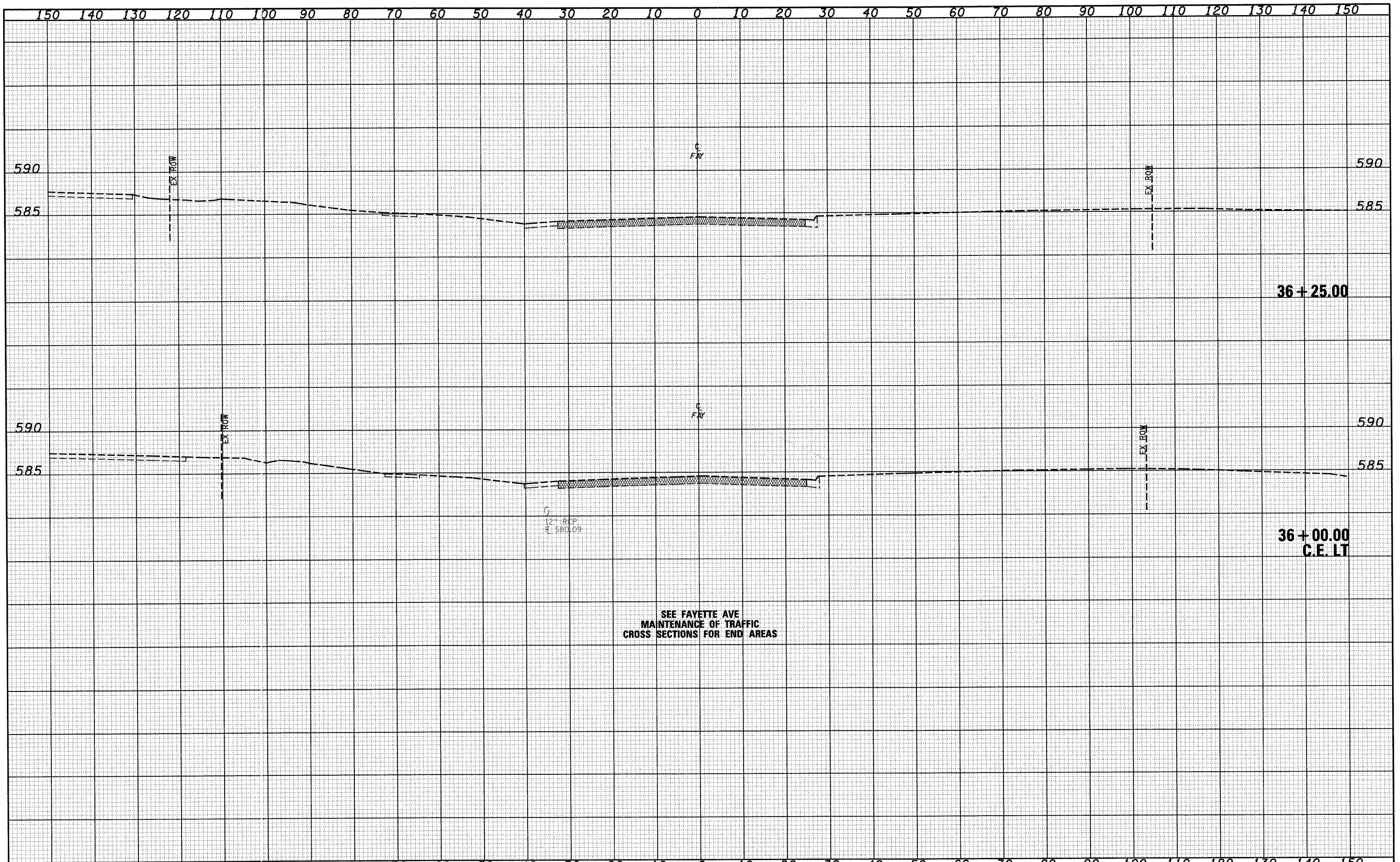

FILE NAME =	USER NAME = lunde	DESIGNED - JWS	REVISED -	STATE OF ILLINOIS DEPARTMENT OF TRANSPORTTION	CROSS SECTIONS, FAYETTE AVE.			F.A. RT.	SECTION	COUNTY	TOTAL SHEETS	SHEET NO.
S:\Projects\103-0002\51-70.dgn\Fayette\cross1.dgn		DRAWN - LEC	REVISED -		SCALE: 1"=10'	SHEET NO. 1 OF 43 SHEETS	STA. 36+00.00 TO STA. 36+25.00	57/70	(25-3)I-6	EFFINGHAM	839	370
		CHECKED - BRM	REVISED -					CONTRACT NO. 74293				
		DATE - 11-05-07	REVISED -					FED. ROAD DIST. NO. ILLINOIS FED. AID PROJECT				

DATE _____
 BY _____
 ORIGINAL SURVEY _____
 SURVEYED _____
 PLOTTED _____
 TEMPLATE _____
 NOTE BOOK _____
 AREAS _____
 AREAS CHECKED _____
 NO. _____

DATE _____
 BY _____
 ORIGINAL SURVEY _____
 SURVEYED _____
 PLOTTED _____
 TEMPLATE _____
 NOTE BOOK _____
 AREAS _____
 AREAS CHECKED _____
 NO. _____

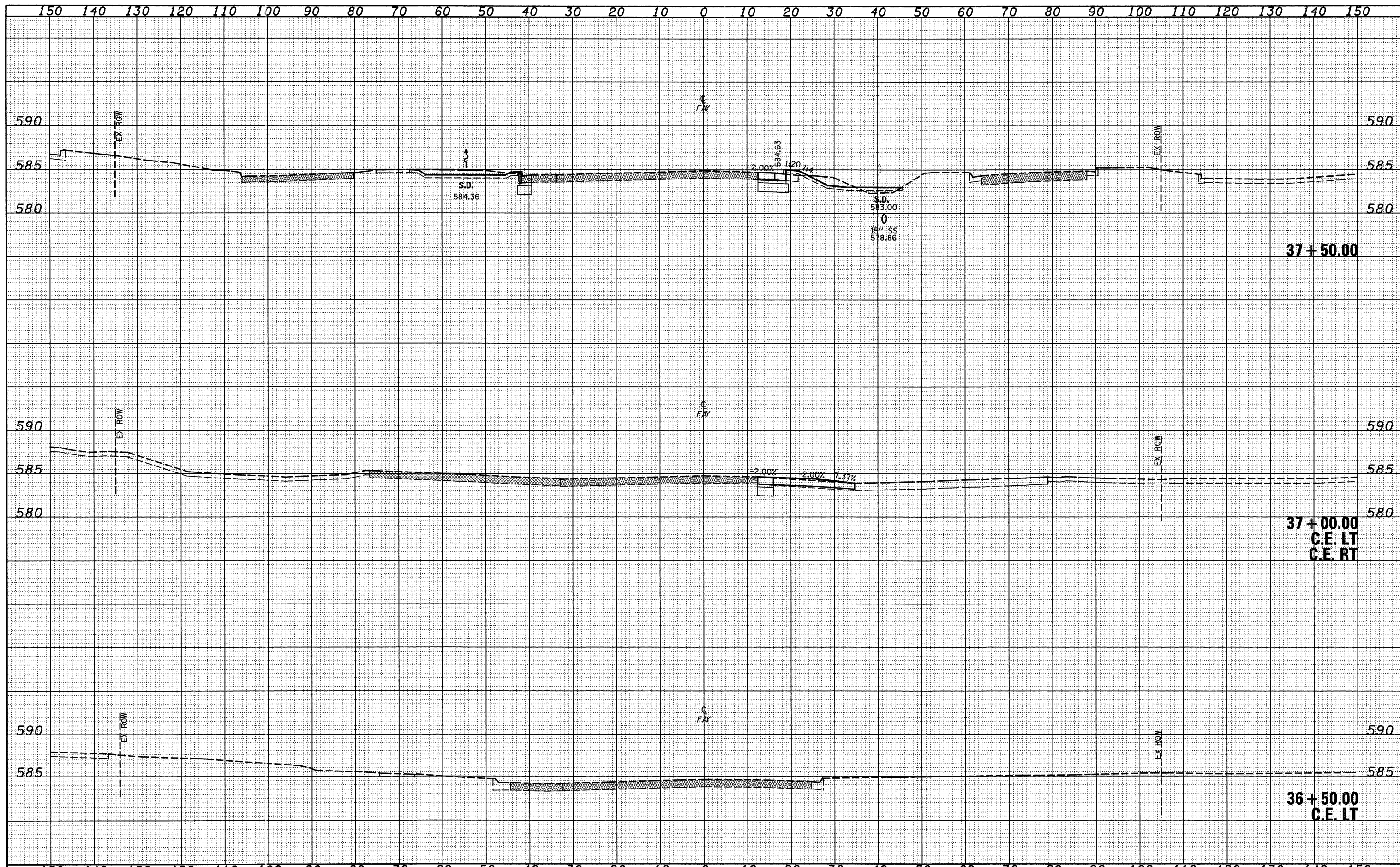

37+50.00

37+00.00
 C.E. LT
 C.E. RT

36+50.00
 C.E. LT

FILE NAME =	USER NAME = jinda	DESIGNED - JWS	REVISED -	STATE OF ILLINOIS DEPARTMENT OF TRANSPORTATION	CROSS SECTIONS, FAYETTE AVE. SCALE: 1"=10' SHEET NO. 2 OF 43 SHEETS STA. 36+50.00 TO STA. 37+50.00	F.A. RT.	SECTION	COUNTY	TOTAL SHEETS	SHEET NO.	
50\Projects\402\0072\57-70\Drawings\Fayette\ssff#1.dgn		DRAWN - LEC	REVISED -			57/70	(25-3)I-6	EFFINGHAM	839	371	
PLOT SCALE = 20,00000' / IN.		CHECKED - BRM	REVISED -			CONTRACT NO. 74293					
PLOT DATE = 6/24/2010		DATE - 11-05-07	REVISED -			FED. ROAD DIST. NO. ILLINOIS FED. AID PROJECT					

DATE _____
 BY _____
 ORIGINAL SURVEY _____
 SURVEYED _____
 PLOTTED _____
 TEMPLATE _____
 NOTE BOOK _____
 AREAS _____
 CHECKED _____
 NO. _____

DATE _____
 BY _____
 ORIGINAL SURVEY _____
 SURVEYED _____
 PLOTTED _____
 TEMPLATE _____
 NOTE BOOK _____
 AREAS _____
 CHECKED _____
 NO. _____

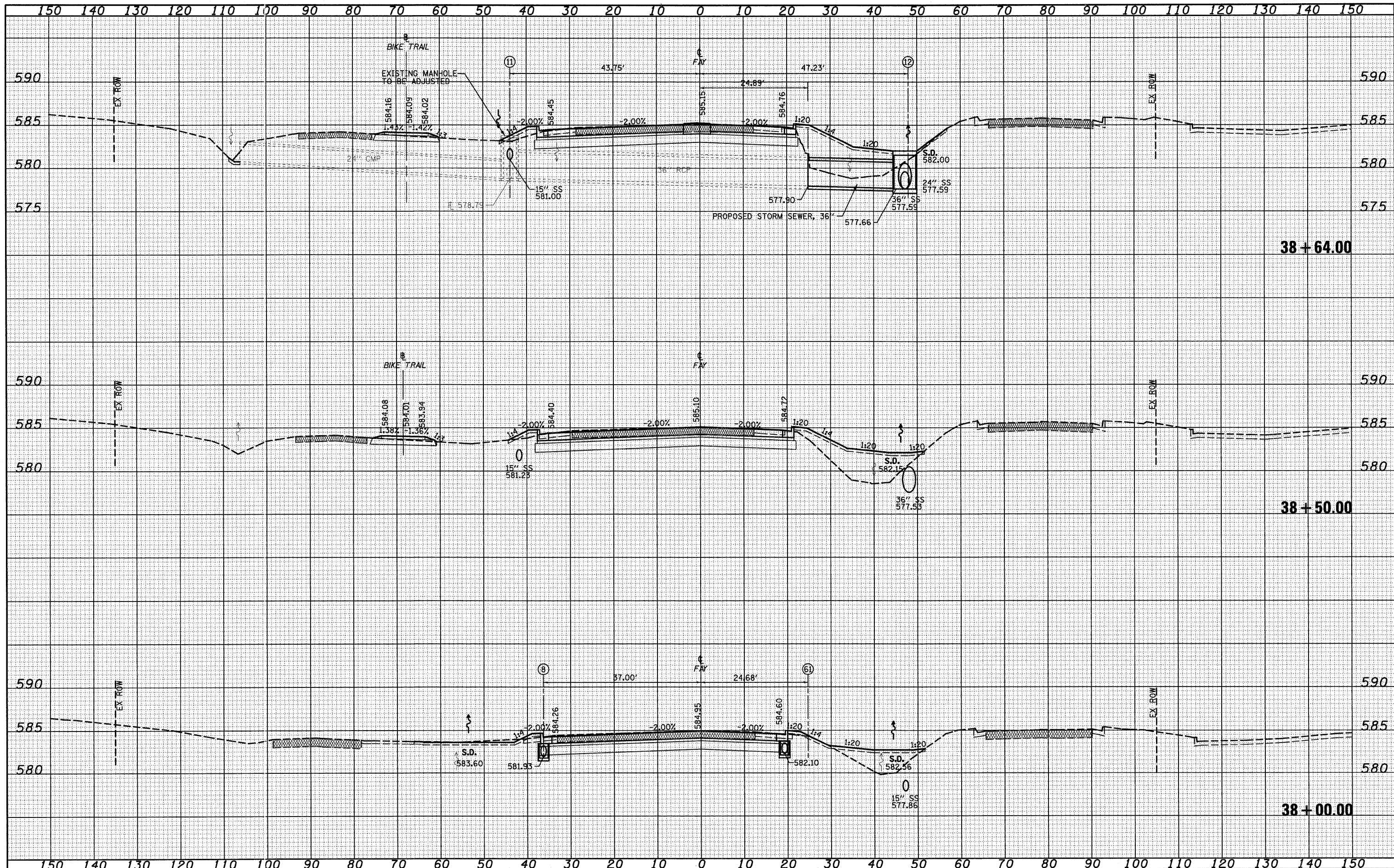

DATE _____
 BY _____
 SURVEYED _____
 PLOTTED _____
 TEMPLATE _____
 NOTE BOOK _____
 AREAS CHECKED _____
 NO. _____

DATE _____
 BY _____
 SURVEYED _____
 PLOTTED _____
 TEMPLATE _____
 NOTE BOOK _____
 AREAS CHECKED _____
 NO. _____

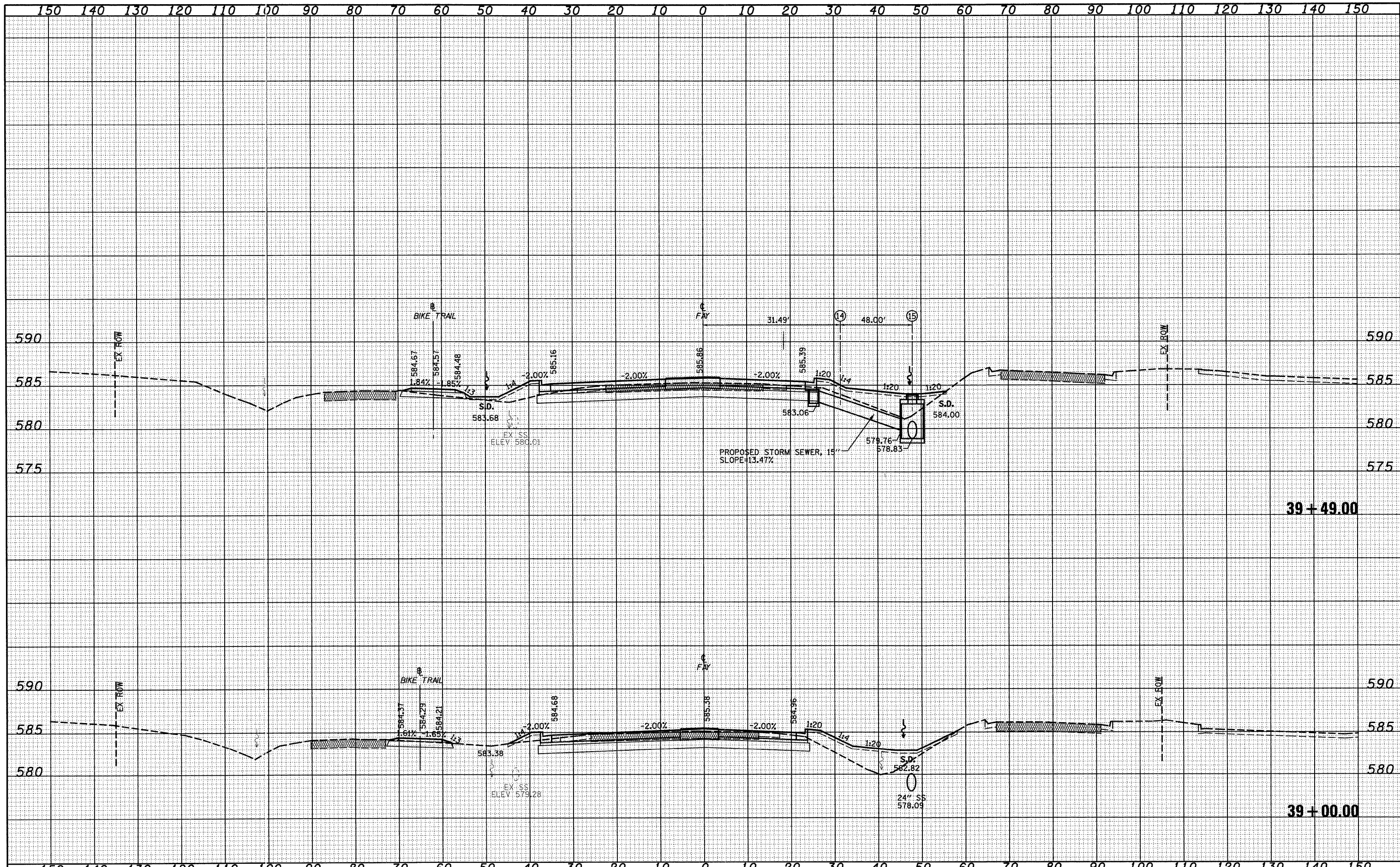

DATE	
BY	
FINAL SURVEY	SURVEYED
NOTE BOOK	PLOTTED
NO.	TEMPLATE
	AREAS
	CHECKED

DATE	
BY	
ORIGINAL SURVEY	SURVEYED
NOTE BOOK	PLOTTED
NO.	TEMPLATE
	AREAS
	CHECKED

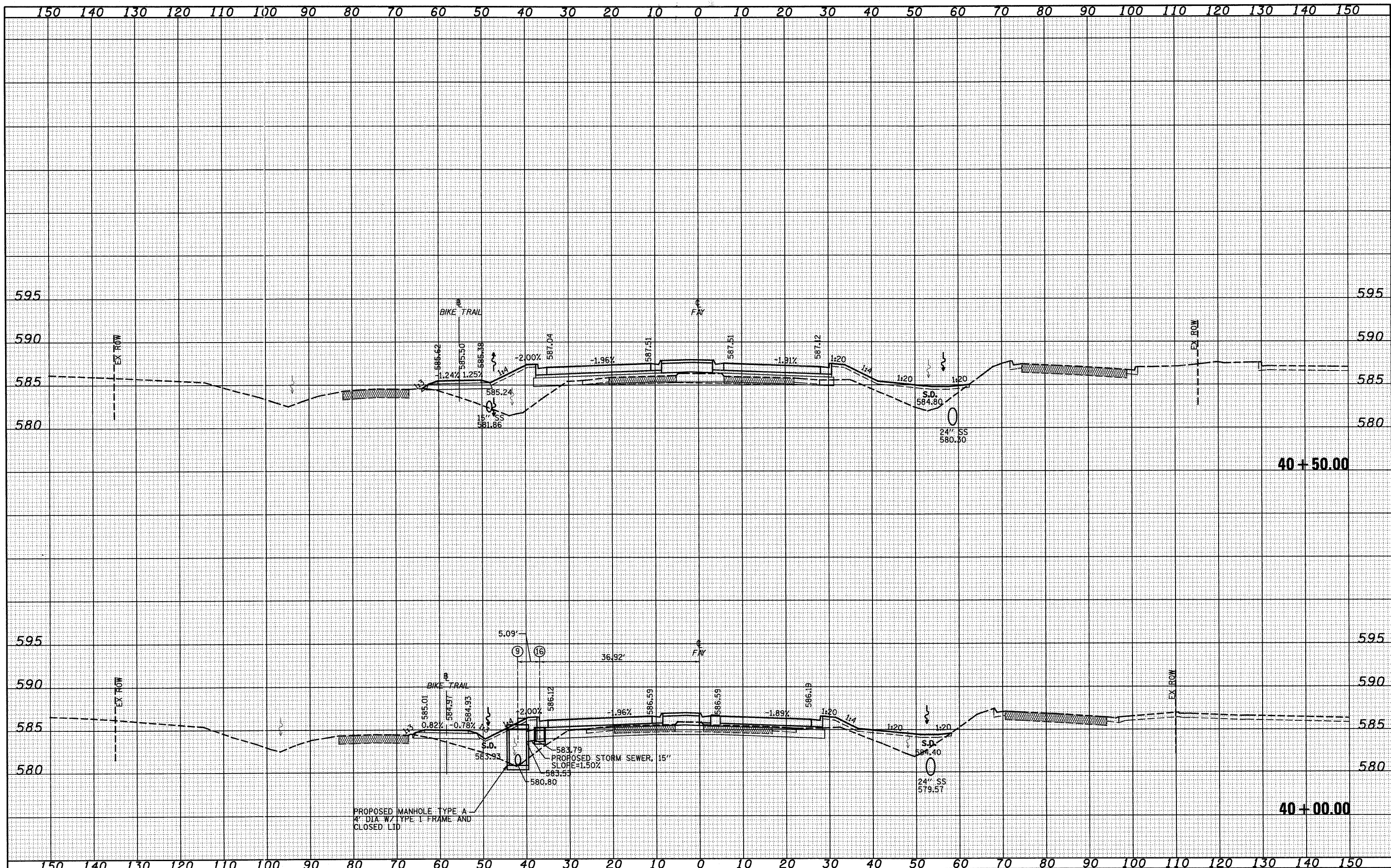

FILE NAME = S:\Projects\03-00072-51-70\cgr\Fayette\cgr\FH.dgn
 USER NAME = l1nda
 PLOT SCALE = 20,0000' / IN.
 PLOT DATE = 6/24/2010

DESIGNED - JWS
 DRAWN - LEC
 CHECKED - BRM
 DATE - 11-05-07

REVISED -
 REVISED -
 REVISED -
 REVISED -

**STATE OF ILLINOIS
 DEPARTMENT OF TRANSPORTATION**

CROSS SECTIONS, FAYETTE AVE.
 SCALE: 1"=10'
 SHEET NO. 5 OF 43 SHEETS
 STA. 40+00.00 TO STA. 40+50.00

R.T.	SECTION	COUNTY	TOTAL SHEETS	SHEET NO.
57/70	(25-3)I-6	EFFINGHAM	839	374
FED. ROAD DIST. NO.		ILLINOIS FED. AID PROJECT		
		CONTRACT NO. 74293		

DATE	
BY	
FINISHED SURVEY	
PLOTTED	
NOTE BOOK	
TEMPLATE	
AREAS CHECKED	
NO.	

DATE	
BY	
ORIGINAL SURVEY	
PLOTTED	
NOTE BOOK	
TEMPLATE	
AREAS CHECKED	
NO.	

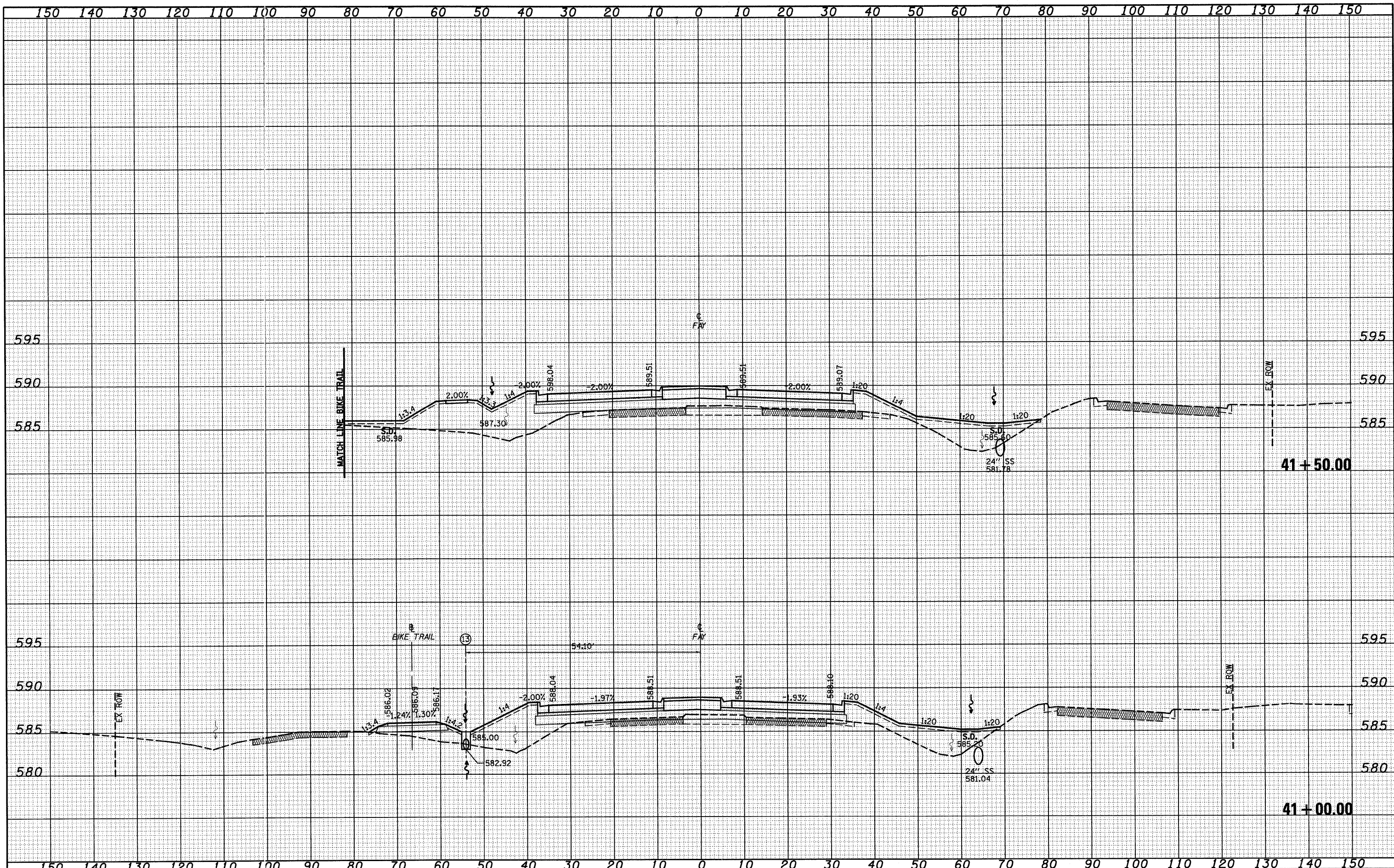

FILE NAME = S:\Projects\03-00072-57-10.dgn\Fayette\cross1.dgn
 USER NAME = Linda
 PLOT SCALE = 20,0000' / IN.
 PLOT DATE = 6/24/2010

DESIGNED - JWS
 DRAWN - LEC
 CHECKED - BRM
 DATE - 11-05-07

REVISED -
 REVISED -
 REVISED -
 REVISED -

**STATE OF ILLINOIS
 DEPARTMENT OF TRANSPORTATION**

CROSS SECTIONS, FAYETTE AVE.

SCALE: 1"=10' SHEET NO. 6 OF 43 SHEETS STA. 41+00.00 TO STA. 41+50.00

F.A. RT. 57/70	SECTION (25-3)I-6	COUNTY EFFINGHAM	TOTAL SHEETS 839	SHEET NO. 375
CONTRACT NO. 74293				
FED. ROAD DIST. NO. ILLINOIS FED. AID PROJECT				

DATE	
BY	
FINAL SURVEY	SURVEYED
NOTE BOOK	PLOTTED
NO.	TEMPLATE
	AREAS CHECKED
	AREAS CHECKED

DATE	
BY	
ORIGINAL SURVEY	SURVEYED
NOTE BOOK	PLOTTED
NO.	TEMPLATE
	AREAS CHECKED
	AREAS CHECKED

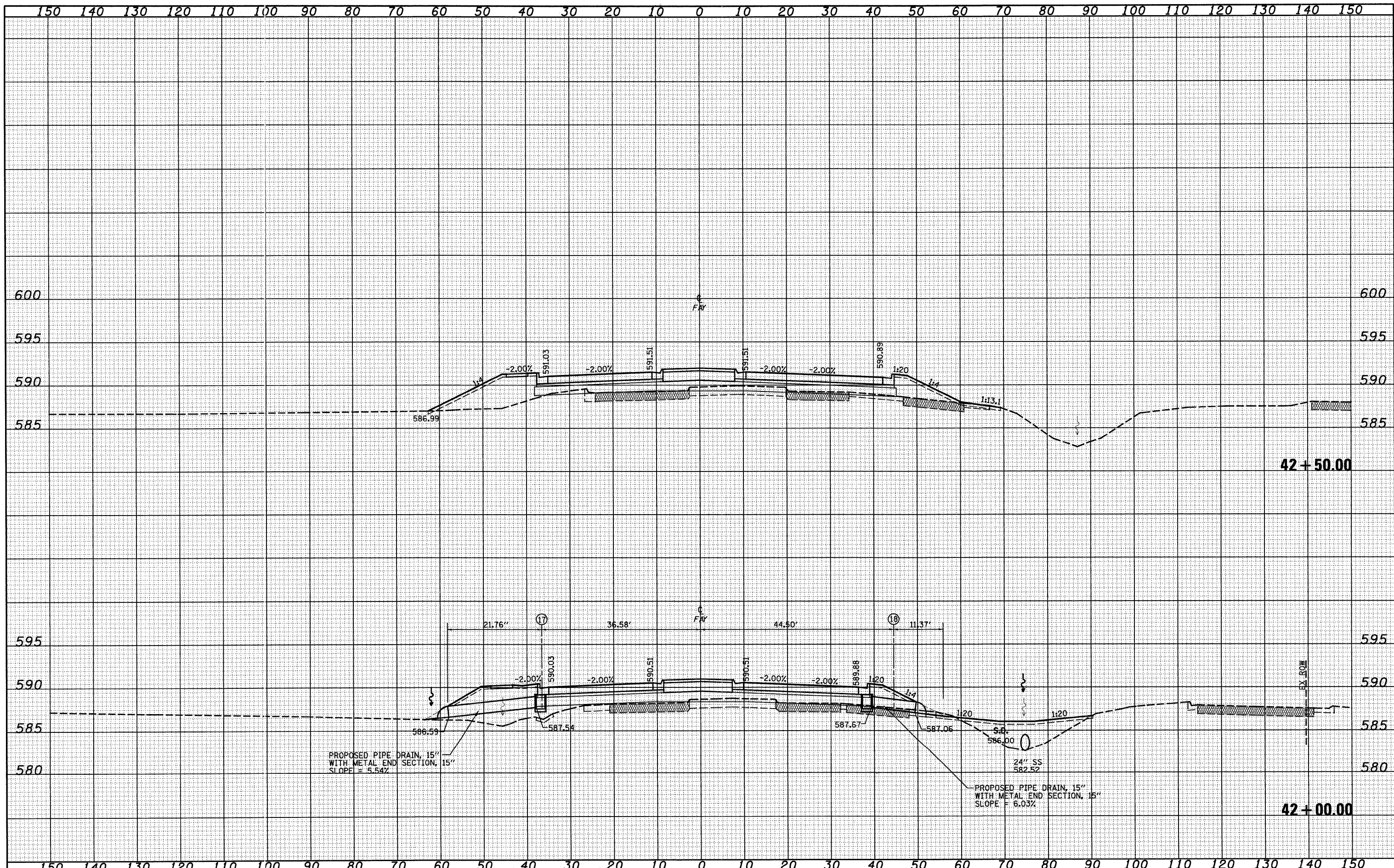

FILE NAME =	USER NAME = lmdo	DESIGNED - JWS	REVISED -	STATE OF ILLINOIS DEPARTMENT OF TRANSPORTATION	CROSS SECTIONS, FAYETTE AVE.			F.A. RT. 57/70	SECTION (25-3)1-6	COUNTY EFFINGHAM	TOTAL SHEETS 839	SHEET NO. 376
PROJECT NO. 88872.57-70.dgn		DRAWN - LEC	REVISED -		SCALE: 1"=10'	SHEET NO. 7 OF 43 SHEETS	STA. 42+00.00 TO STA. 42+50.00	FED. ROAD DIST. NO.	ILLINOIS FED. AID PROJECT	CONTRACT NO. 74293		
		CHECKED - BRM	REVISED -									
		DATE - 11-05-07	REVISED -									

BY	DATE
FINAL SURVEY	SURVEYED
NOTE BOOK	PLOTTED
NO.	TEMPLATE
	AREAS CHECKED

BY	DATE
ORIGINAL SURVEY	SURVEYED
NOTE BOOK	PLOTTED
NO.	TEMPLATE
	AREAS CHECKED

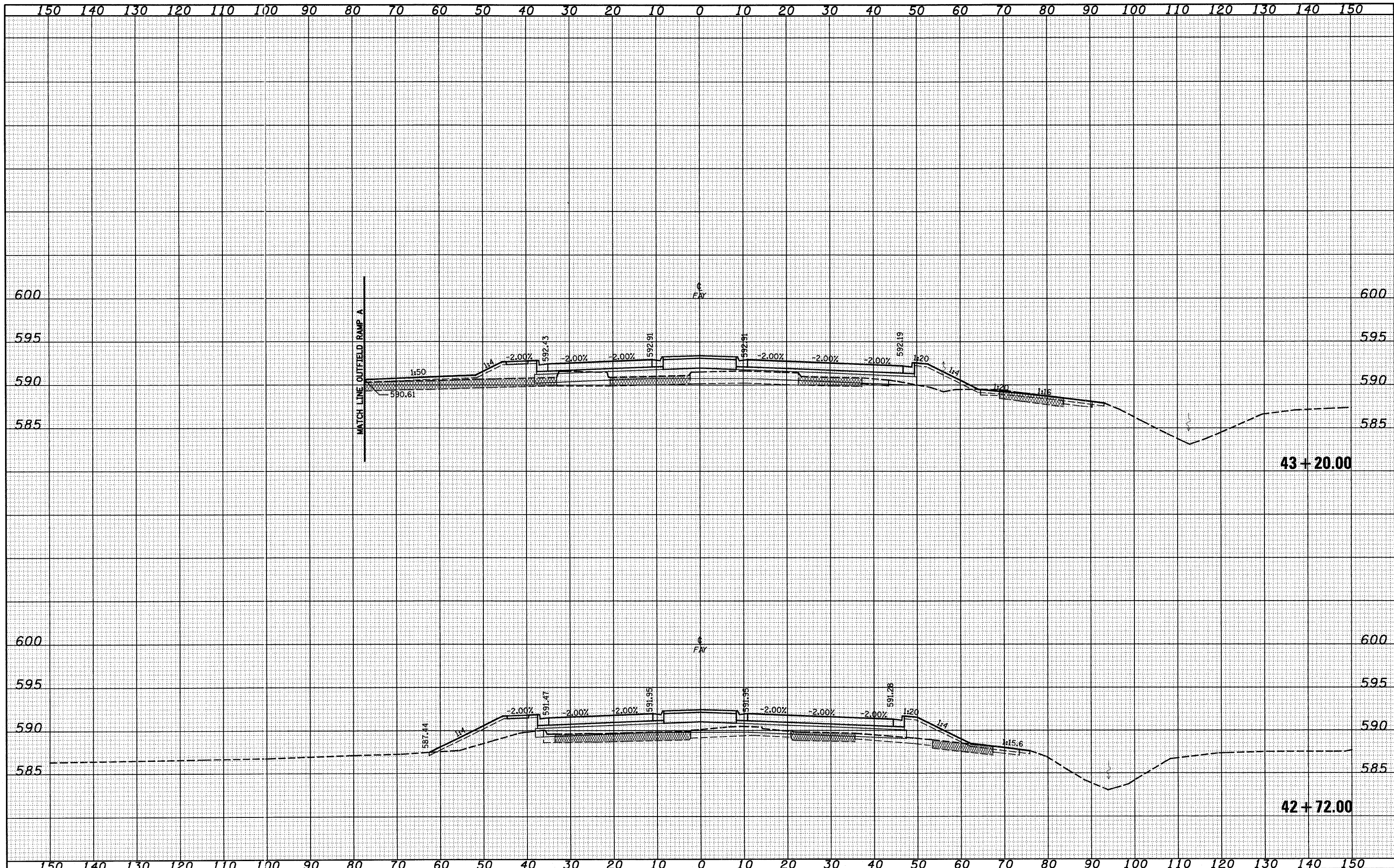

FILE NAME = \\projects\400-00072-57-70\p\figural\cross\ff1.dgn
 USER NAME = linda
 PLOT SCALE = 20,0000' / IN.
 PLOT DATE = 6/24/2010

DESIGNED - JWS
 DRAWN - LEC
 CHECKED - BRM
 DATE - 11-05-07

REVISED -
 REVISED -
 REVISED -
 REVISED -

**STATE OF ILLINOIS
 DEPARTMENT OF TRANSPORTATION**

CROSS SECTIONS, FAYETTE AVE.
 SCALE: 1"=10' SHEET NO. 8 OF 43 SHEETS STA. 42+72.00 TO STA. 43+20.00

F.A. RT.	SECTION	COUNTY	TOTAL SHEETS	SHEET NO.
57/70	(25-3)I-6	EFFINGHAM	839	377
CONTRACT NO. 74293				
FED. ROAD DIST. NO. ILLINOIS FED. AID PROJECT				

BY: _____ DATE: _____
 SURVEYED: _____ PLOTTED: _____
 NOTE BOOK: _____ TEMPLATE: _____
 AREAS CHECKED: _____
 NO.:

BY: _____ DATE: _____
 SURVEYED: _____ PLOTTED: _____
 NOTE BOOK: _____ TEMPLATE: _____
 AREAS CHECKED: _____
 NO.:

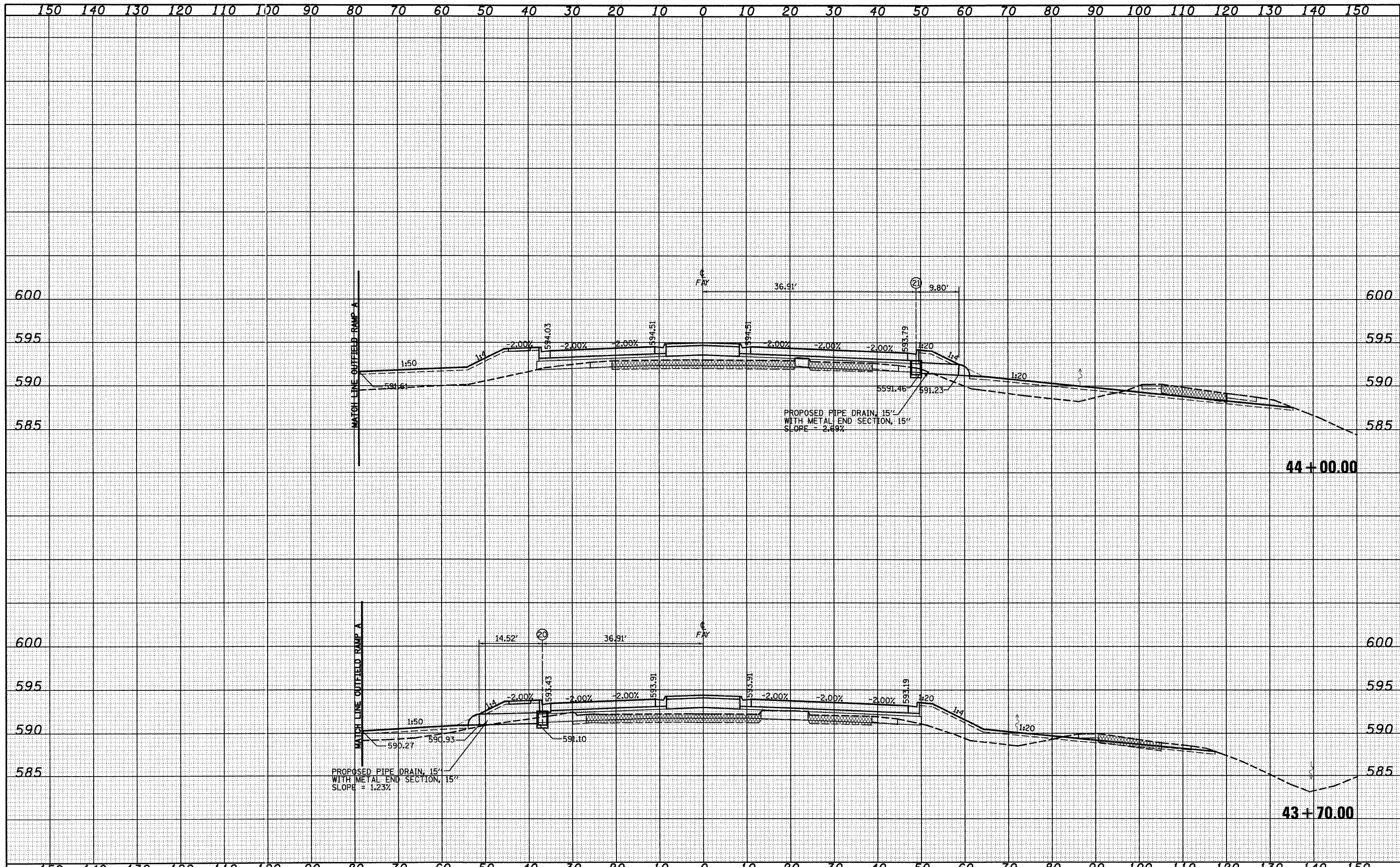

FILE NAME =	USER NAME = lnda	DESIGNED - JWS	REVISED -	STATE OF ILLINOIS DEPARTMENT OF TRANSPORTATION	CROSS SECTIONS, FAYETTE AVE.	F.A. RT. 57/70	SECTION (25-3)I-6	COUNTY EFFINGHAM	TOTAL SHEETS 839	SHEET NO. 378	
PROJECT: 43-0072.57-70dgr/fayette/vesh/fd.dgn	PLOT SCALE = 20,0000' / IN.	DRAWN - LEC	REVISED -			SCALE: 1"=10'	SHEET NO. 9 OF 43 SHEETS	STA. 43+70.00 TO STA. 44+00.00	FED. ROAD DIST. NO. [ILLINOIS] FED. AID PROJECT	CONTRACT NO. 74293	
	PLOT DATE = 6/24/2010	CHECKED - BRM	REVISED -								
		DATE - 11-05-07	REVISED -								

DATE	
BY	
FINAL SURVEY	SURVEYED
NOTE BOOK	PLOTTED
NO.	TEMPLATE
	AREAS
	CHECKED

DATE	
BY	
ORIGINAL SURVEY	SURVEYED
NOTE BOOK	PLOTTED
NO.	TEMPLATE
	AREAS
	CHECKED

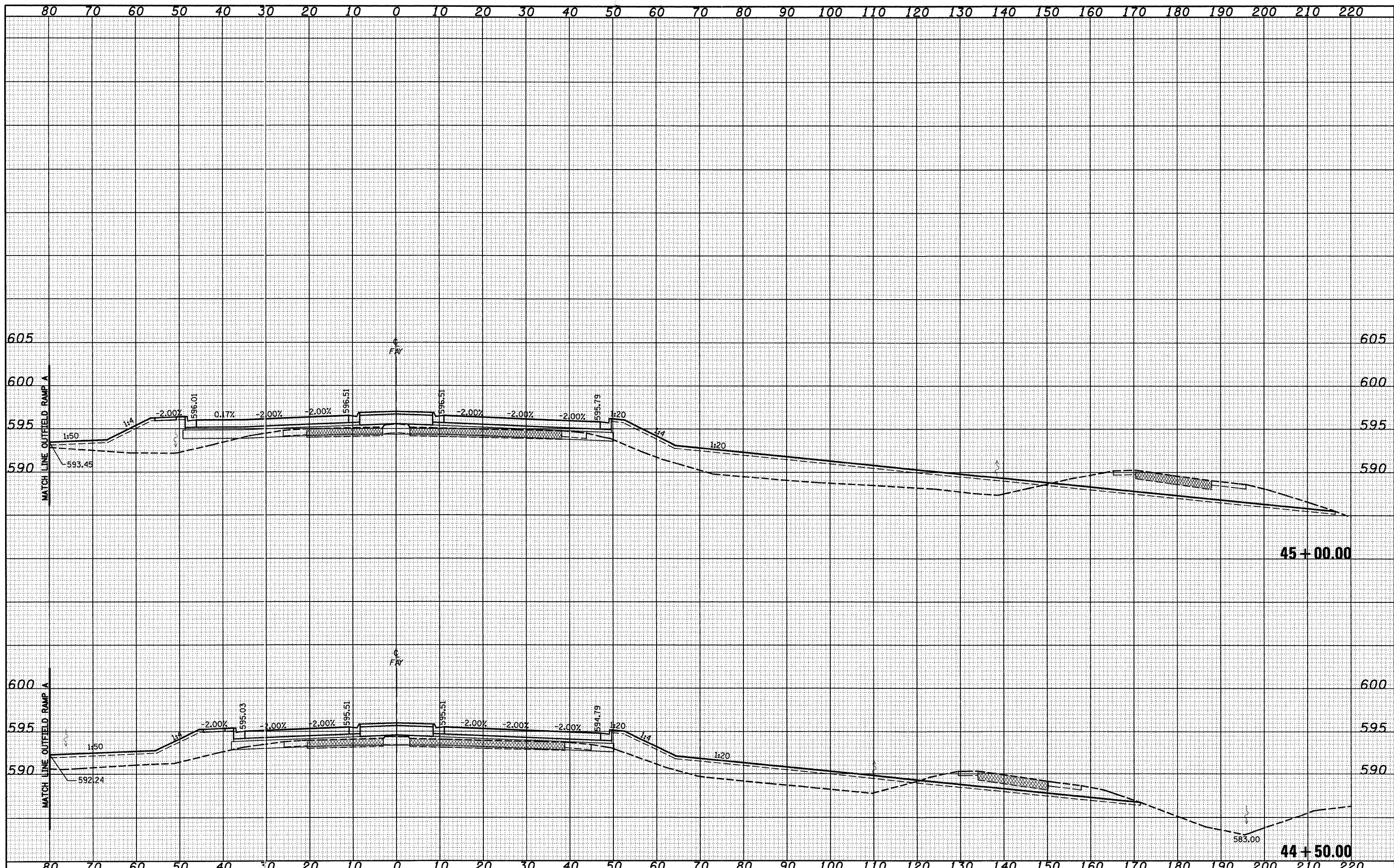

FILE NAME =
 PROJECT: 052-0007-57-700-Fayette/ussf11.dgn

USER NAME = lnda
 PLOT SCALE = 20.0000' / IN.
 PLOT DATE = 6/24/2010

DESIGNED - JWS
 DRAWN - LEC
 CHECKED - BRM
 DATE - 11-05-07

REVISED -
 REVISED -
 REVISED -
 REVISED -

**STATE OF ILLINOIS
 DEPARTMENT OF TRANSPORTATION**

CROSS SECTIONS, FAYETTE AVE.

SCALE: 1"=10' SHEET NO. 10 OF 43 SHEETS STA. 44+50.00 TO STA. 45+00.00

F.A. RT. 57/70	SECTION (25-3)1-6	COUNTY EFFINGHAM	TOTAL SHEETS 839	SHEET NO. 379
FED. ROAD DIST. NO. ILLINOIS FED. AID PROJECT			CONTRACT NO. 74293	

BY	DATE
FINL SURVEY	SURVEYED
NOTE BOOK	PLOTTED
NO.	TEMPLATE
	AREAS CHECKED

BY	DATE
ORIGINAL SURVEY	SURVEYED
NOTE BOOK	PLOTTED
NO.	TEMPLATE
	AREAS CHECKED

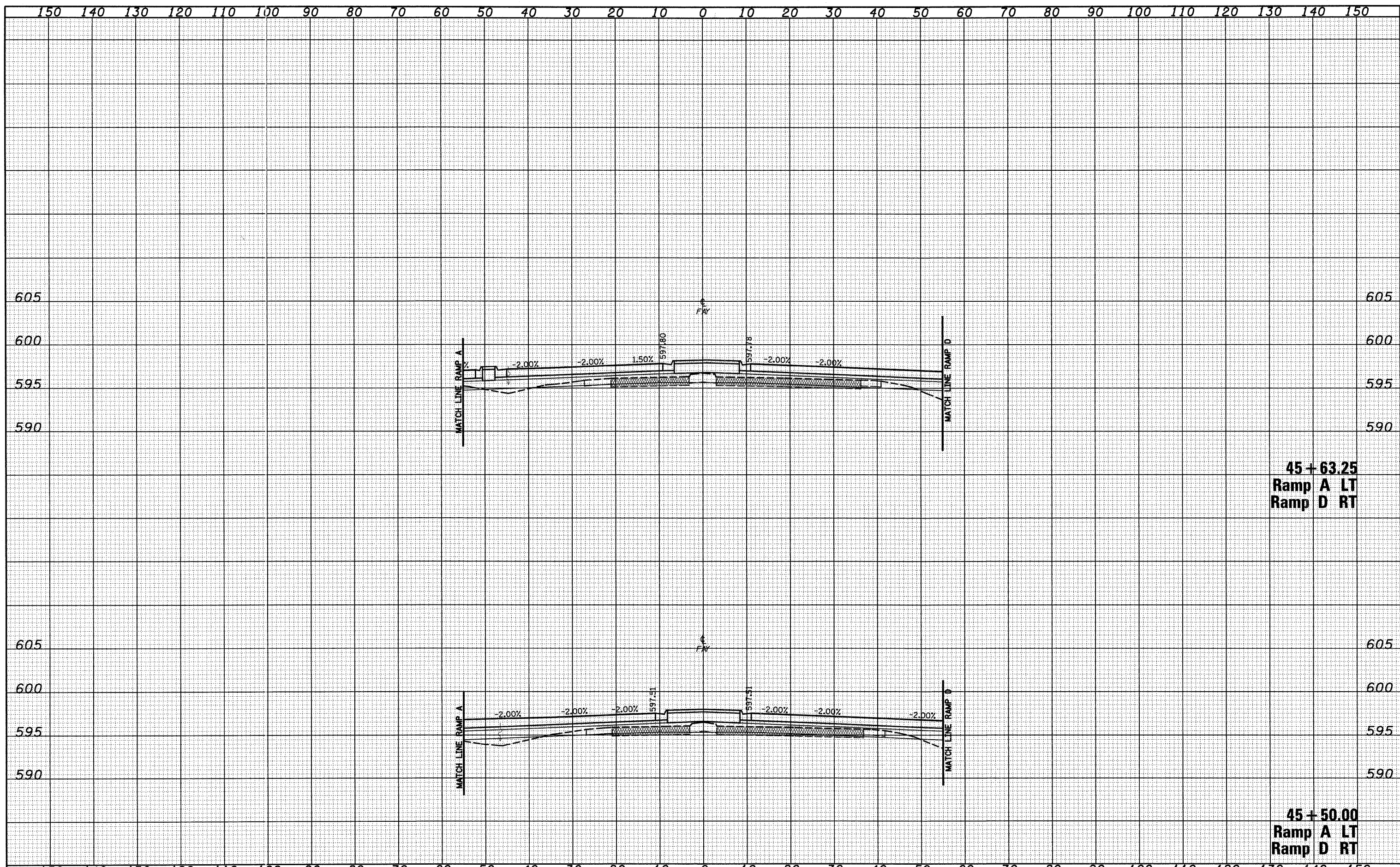

45 + 63.25
Ramp A LT
Ramp D RT

45 + 50.00
Ramp A LT
Ramp D RT

FILE NAME =	USER NAME = imda	DESIGNED - JWS	REVISED -	STATE OF ILLINOIS DEPARTMENT OF TRANSPORTATION	CROSS SECTIONS, FAYETTE AVE.			F.A. RT.	SECTION	COUNTY	TOTAL SHEETS	SHEET NO.
50\Projects\08-00072-57-70\dp\Fayette\ss\H1.dwg		DRAWN - LEC	REVISED -		SCALE: 1"=10'	SHEET NO. 11 OF 43 SHEETS	STA. 45+50.00 TO STA. 45+63.25	57/70	(25-3)I-6	EFFINGHAM	839	380
		CHECKED - BRM	REVISED -									
		DATE - 11-05-07	REVISED -									
								CONTRACT NO. 74293		ILLINOIS FED. AID PROJECT		

BY: _____ DATE: _____
 FINAL SURVEY SURVEYED _____
 NOTE BOOK PLOTTED _____
 NO. AREAS CHECKED _____

BY: _____ DATE: _____
 ORIGINAL SURVEY SURVEYED _____
 NOTE BOOK PLOTTED _____
 NO. AREAS CHECKED _____

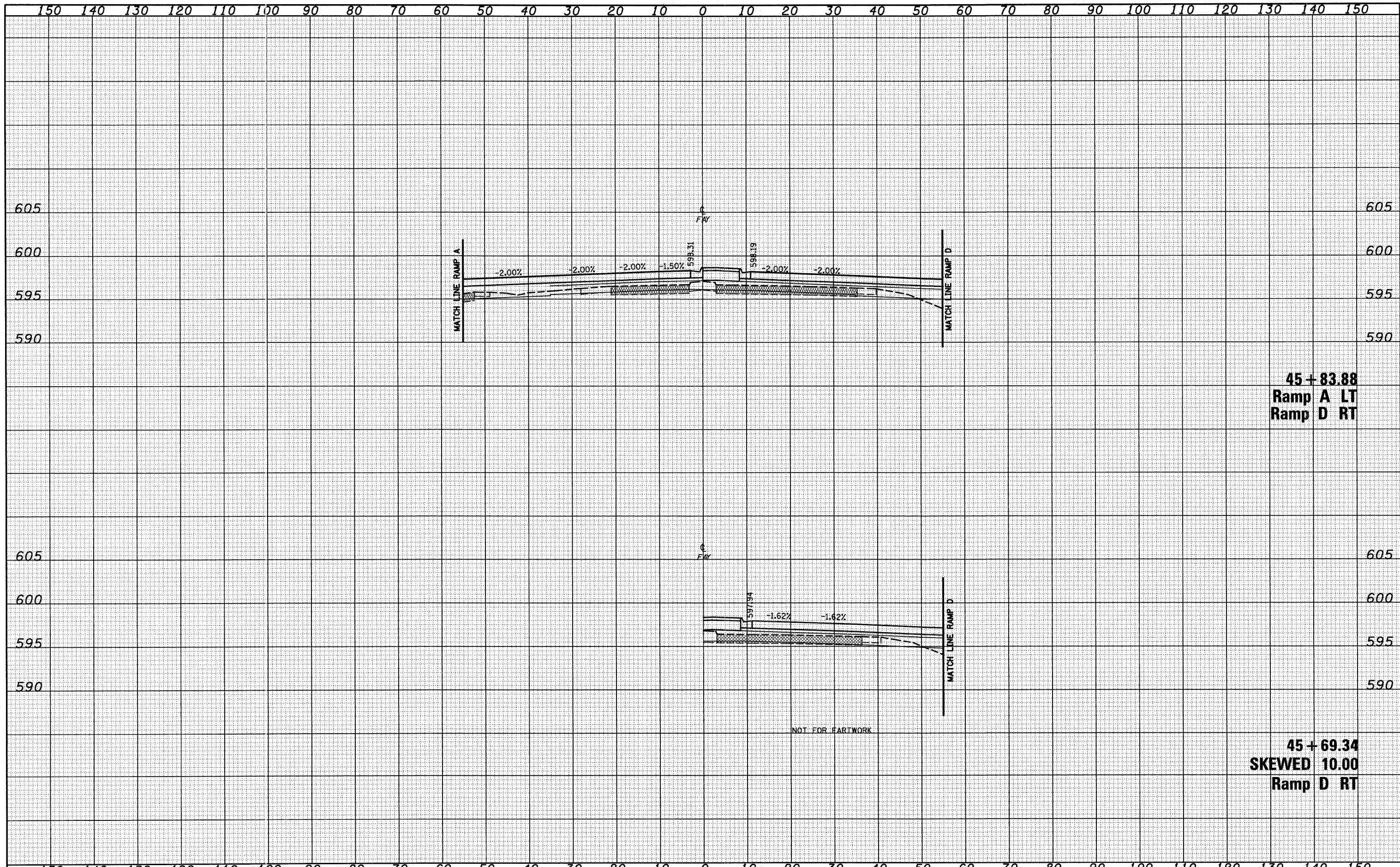

45 + 83.88
Ramp A LT
Ramp D RT

45 + 69.34
SKEWED 10.00
Ramp D RT

BY	DATE
FINAL SURVEY	SURVEYED
NOTE BOOK	PLOTTED
NO.	TEMPLATE
	AREAS CHECKED

BY	DATE
ORIGINAL SURVEY	SURVEYED
NOTE BOOK	PLOTTED
NO.	TEMPLATE
	AREAS CHECKED

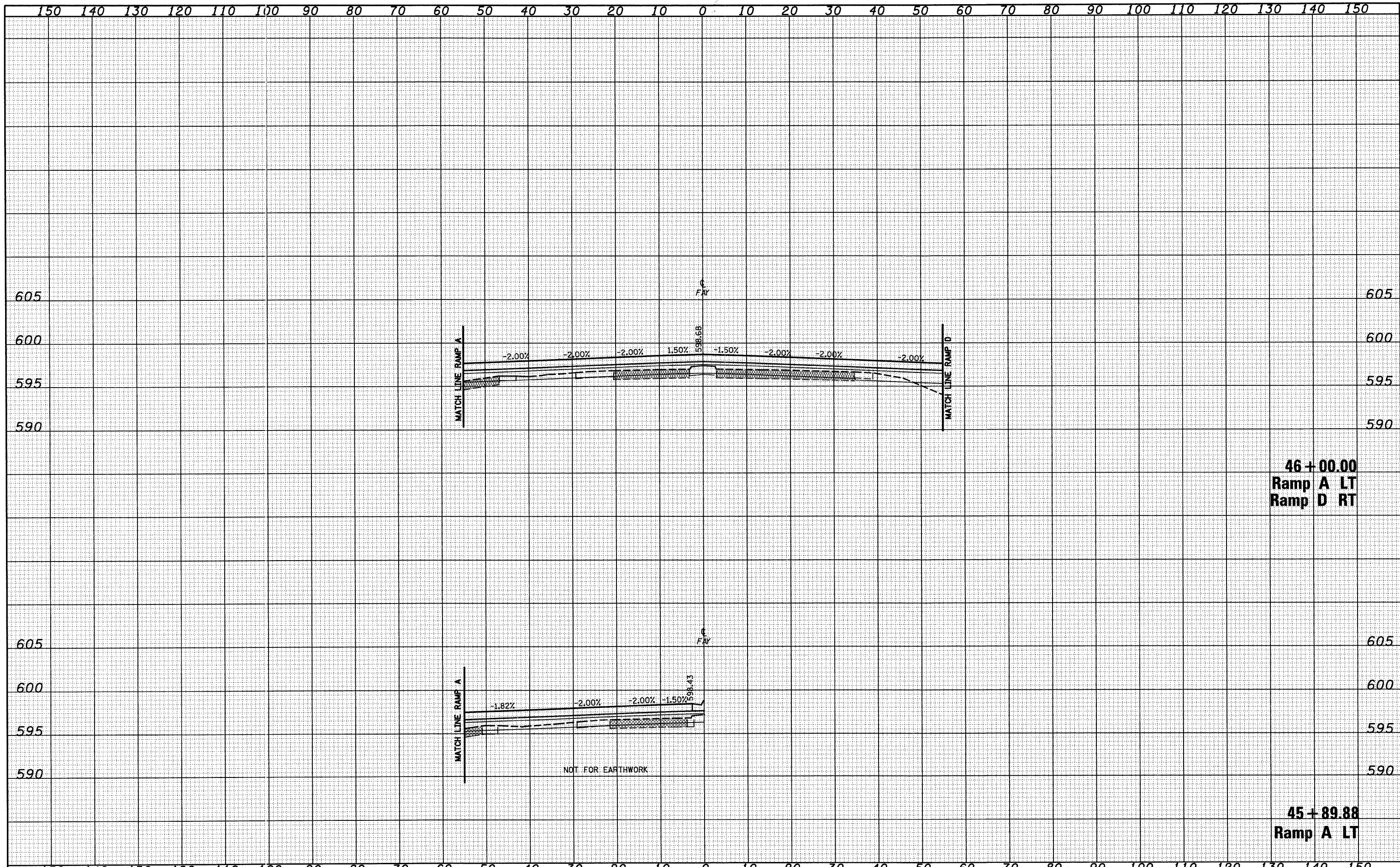

46 + 00.00
Ramp A LT
Ramp D RT

45 + 89.88
Ramp A LT

FILE NAME = S:\Projects\03-0007\57-70\Drawings\Fayette\SS13.HLog

USER NAME = Linda
DESIGNED - JWS
DRAWN - LEC
CHECKED - BRM
DATE - 11-05-07

REVISED -
REVISED -
REVISED -
REVISED -

**STATE OF ILLINOIS
DEPARTMENT OF TRANSPORTATION**

CROSS SECTIONS, FAYETTE AVE.

SCALE: 1"=10' SHEET NO. 13 OF 43 SHEETS STA. 45+89.88 TO STA. 46+00.00

F.A. RT. 57/70	SECTION (25-3)I-6	COUNTY EFFINGHAM	TOTAL SHEETS 839	SHEET NO. 382
FED. ROAD DIST. NO. ILLINOIS FED. AID PROJECT			CONTRACT NO. 74293	

DATE _____
 BY _____
 SURVEYED _____
 PLOTTED _____
 ORIGINAL SURVEY _____
 NOTE BOOK _____
 AREAS CHECKED _____

DATE _____
 BY _____
 SURVEYED _____
 PLOTTED _____
 ORIGINAL SURVEY _____
 NOTE BOOK _____
 AREAS CHECKED _____

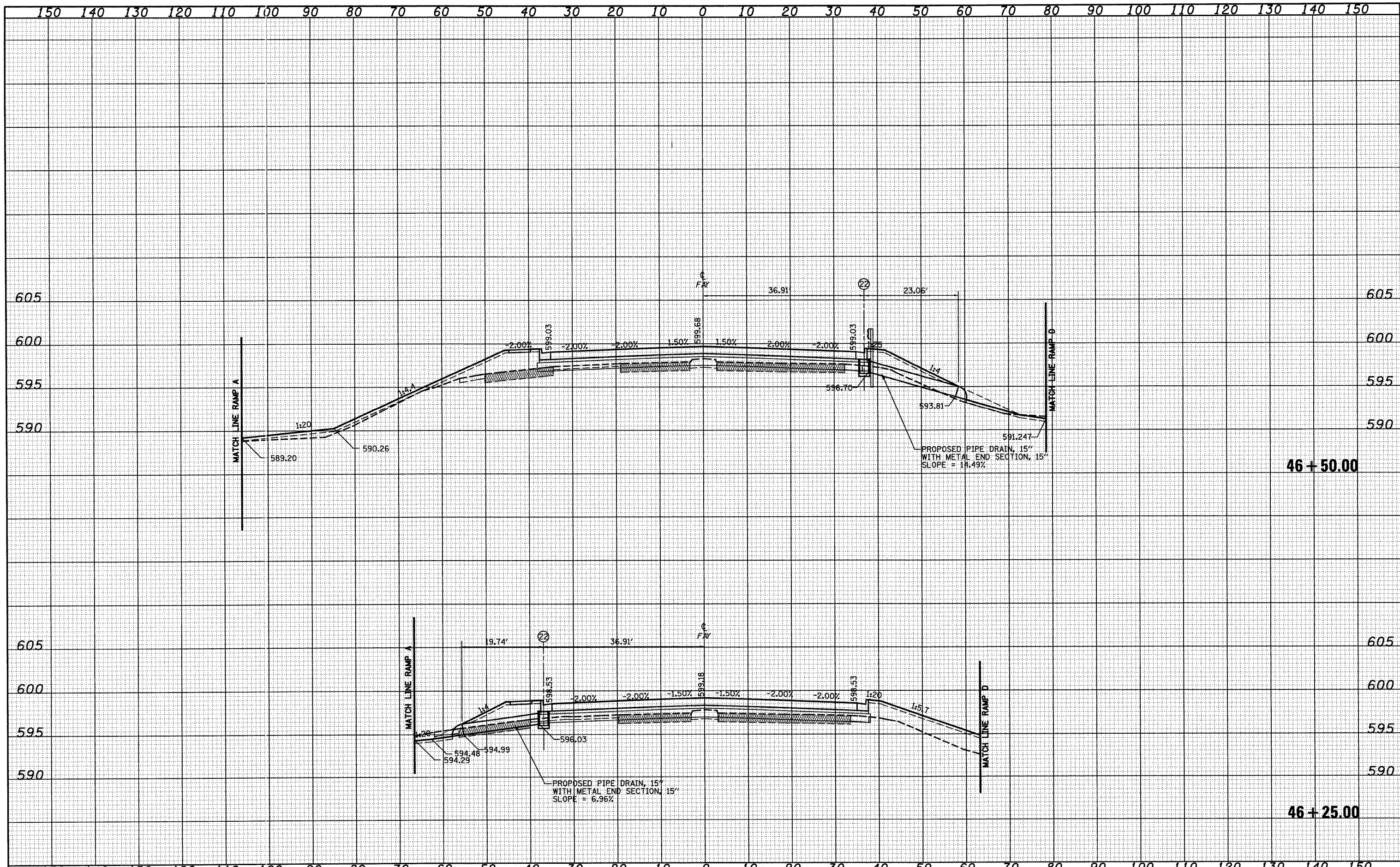

FILE NAME =	USER NAME = linda	DESIGNED - JWS	REVISED -	STATE OF ILLINOIS DEPARTMENT OF TRANSPORTATION	CROSS SECTIONS, FAYETTE AVE.			F.A. RT. 57/70	SECTION (25-3)I-6	COUNTY EFFINGHAM	TOTAL SHEETS 839	SHEET NO. 383
PLOT SCALE = 20.0000' / IN.					DRAWN - LEC	REVISED -	SCALE: 1"=10'	SHEET NO. 14 OF 43 SHEETS	STA. 46+25.00 TO STA. 46+50.00	CONTRACT NO. 74293		
PLOT DATE = 6/24/2010					CHECKED - BRM	REVISED -	ILLINOIS FED. AID PROJECT					
					DATE - 11-05-07	REVISED -						

DATE: _____
 BY: _____
 SURVEYED: _____
 PLOTTED: _____
 ORIGINAL SURVEY: _____
 NOTE BOOK: _____
 AREAS CHECKED: _____
 NO. _____

DATE: _____
 BY: _____
 SURVEYED: _____
 PLOTTED: _____
 ORIGINAL SURVEY: _____
 NOTE BOOK: _____
 AREAS CHECKED: _____
 NO. _____

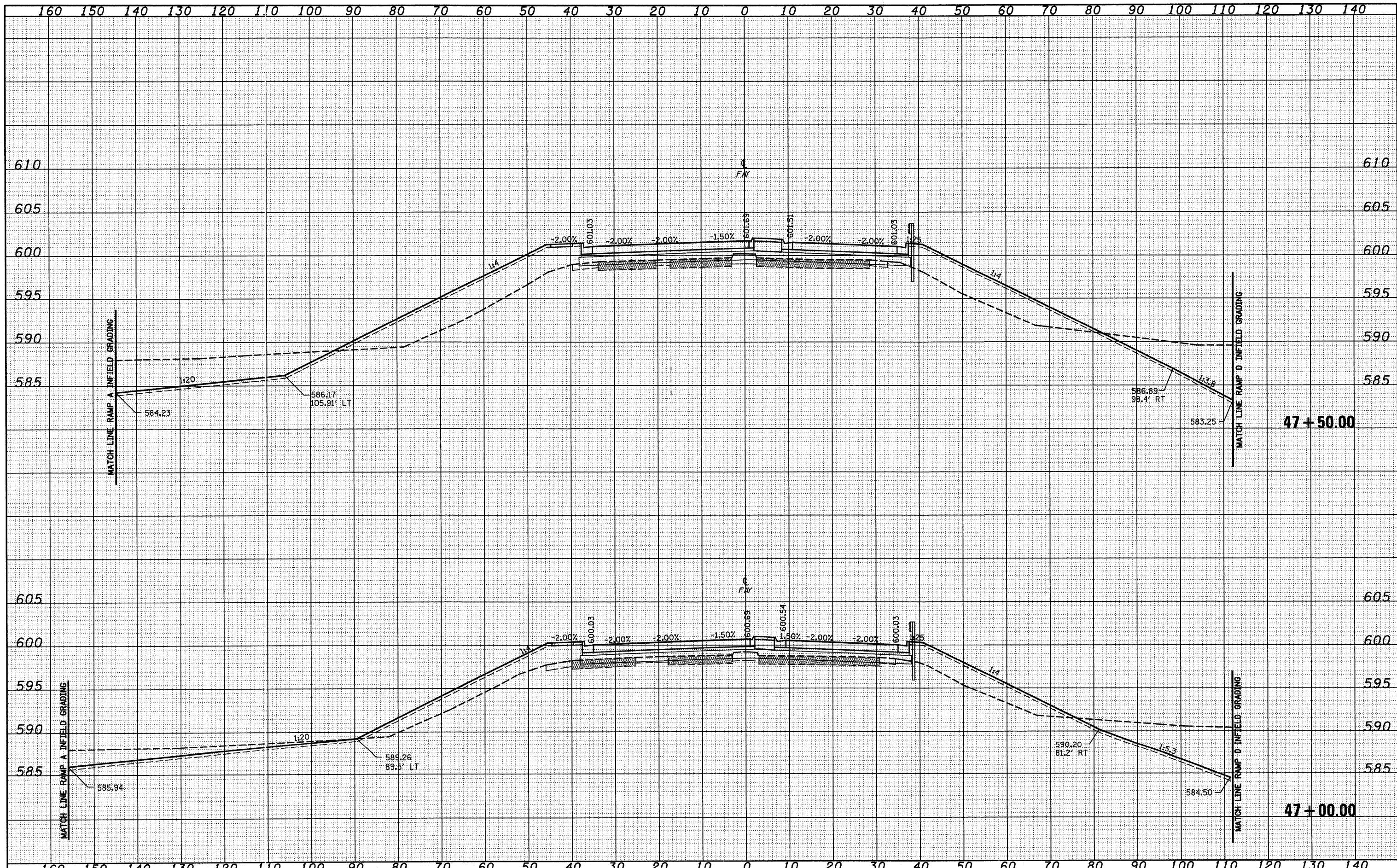

FILE NAME =	USER NAME = linda	DESIGNED - JWS	REVISED -	STATE OF ILLINOIS DEPARTMENT OF TRANSPORTATION	CROSS SECTIONS, FAYETTE AVE.			F.A. RT. 57/70	SECTION (25-3)I-6	COUNTY EFFINGHAM	TOTAL SHEETS 839	SHEET NO. 384
3:\Projects\03-0007257-70.dgn\Fayette\rsd\FM.dgn	PLOT SCALE = 20,0000' / IN.	DRAWN - LEC	REVISED -		SCALE: 1"=10'	SHEET NO. 15 OF 43 SHEETS	STA. 47+00.00 TO STA. 47+50.00	CONTRACT NO. 74293				
	PLOT DATE = 6/24/2010	CHECKED - BRM	REVISED -		FED. ROAD DIST. NO. ILLINOIS FED. AID PROJECT							
		DATE - 11-05-07	REVISED -									

DATE	
BY	
FINAL SURVEY	
PLOTTED	
NOTE BOOK	
AREAS CHECKED	
NO.	

DATE	
BY	
ORIGINAL SURVEY	
PLOTTED	
NOTE BOOK	
AREAS CHECKED	
NO.	

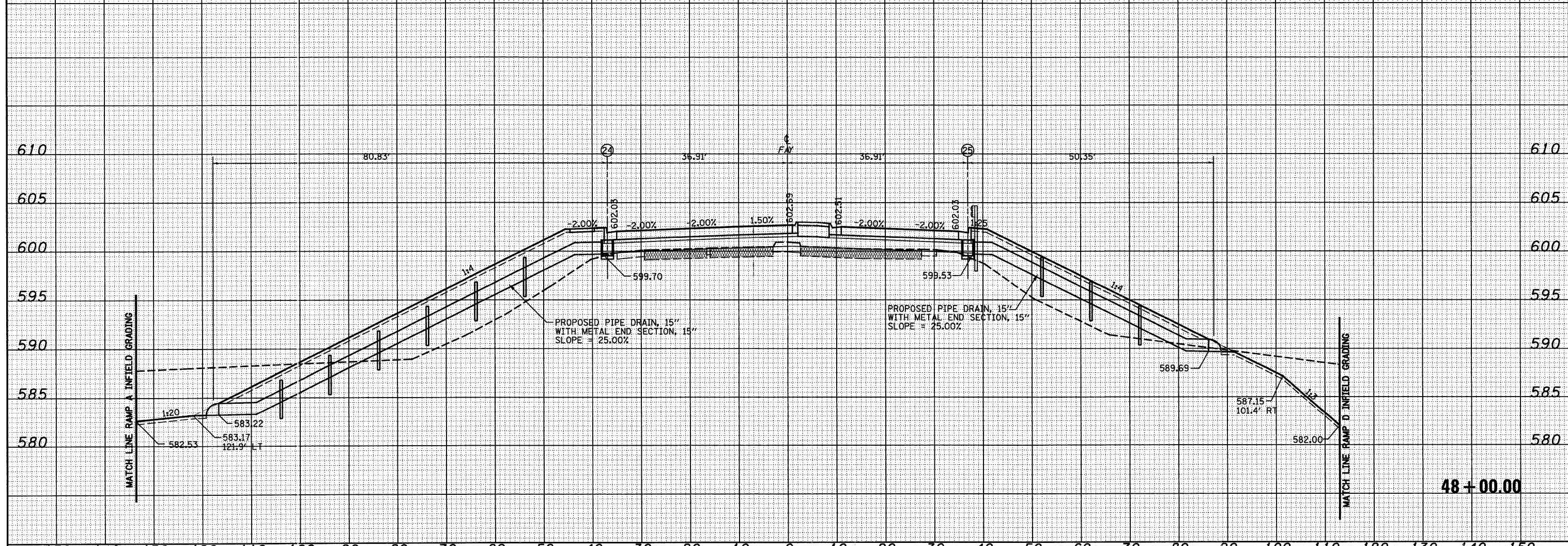
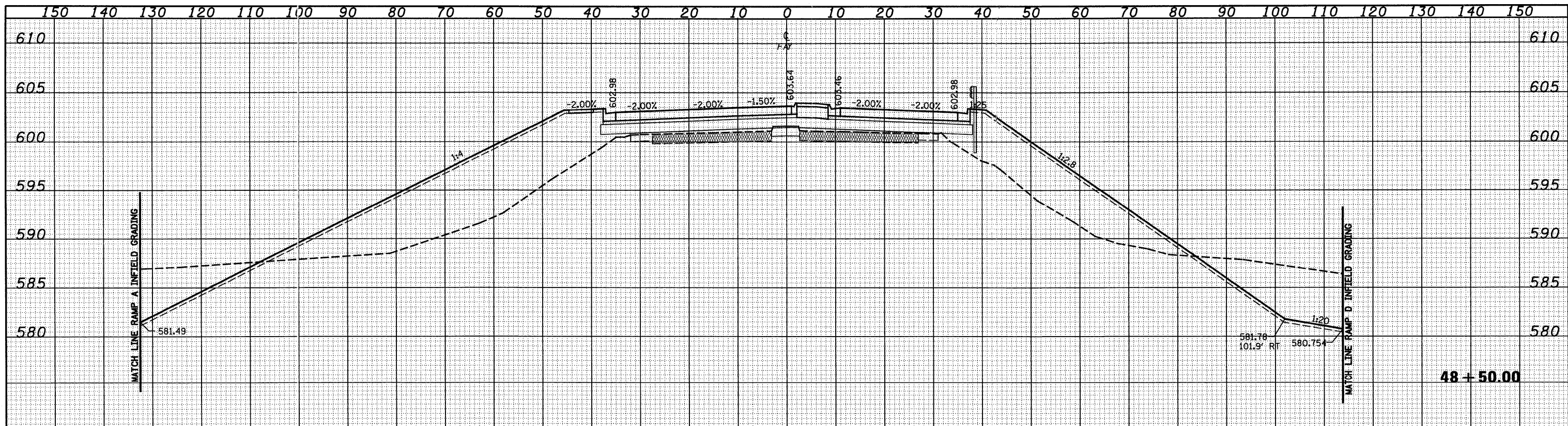

FILE NAME =	USER NAME = linda	DESIGNED - JWS	REVISED -	STATE OF ILLINOIS DEPARTMENT OF TRANSPORTATION	CROSS SECTIONS, FAYETTE AVE.			F.A. RT.	SECTION	COUNTY	TOTAL SHEETS	SHEET NO.
PROJECT: 003-0007-57-7(Indy)FayetteAveS11.dwg	PLT SCALE = 20,0000' / IN.	DRAWN - LEC	REVISED -		SCALE: 1"=10'	SHEET NO. 16 OF 43 SHEETS	STA. 48+00.00 TO STA. 48+50.00	57/70	(25-3)I-6	EFFINGHAM	839	385
PLT DATE = 6/24/2010	DATE - 11-05-07	CHECKED - BRM	REVISED -					CONTRACT NO. 74293				
		DATE - 11-05-07	REVISED -					FED. ROAD DIST. NO. ILLINOIS FED. AID PROJECT				

DATE	
BY	
FINAL SURVEY	
PLOTTED	
NOTE BOOK	
NO.	
AREAS CHECKED	

DATE	
BY	
ORIGINAL SURVEY	
PLOTTED	
NOTE BOOK	
NO.	
AREAS CHECKED	

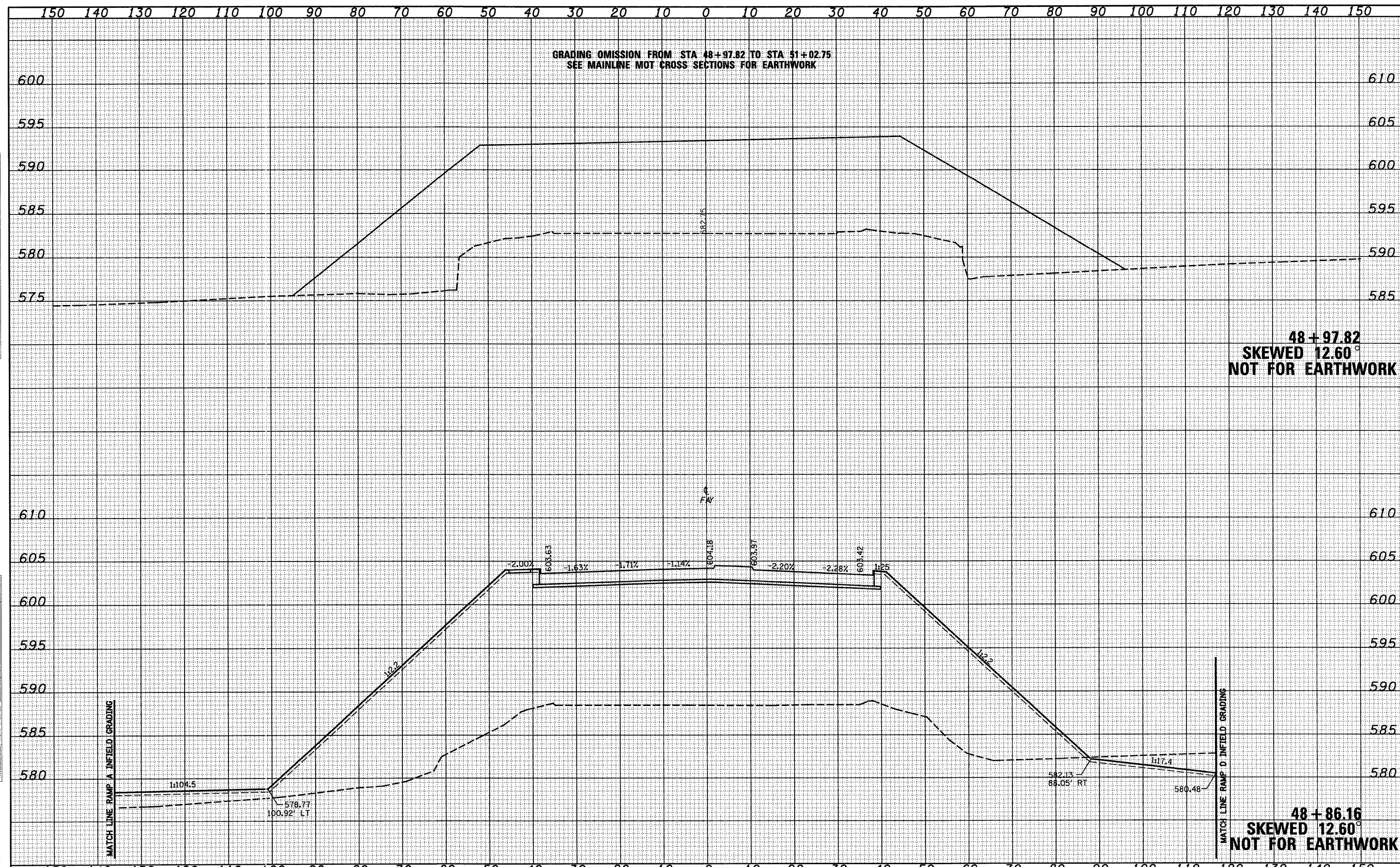

48 + 97.82
SKewed 12.60°
NOT FOR EARTHWORK

48 + 86.16
SKewed 12.60°
NOT FOR EARTHWORK

FILE NAME =	USER NAME = l1nda	DESIGNED - JWS	REVISED -	STATE OF ILLINOIS DEPARTMENT OF TRANSPORTATION	CROSS SECTIONS, FAYETTE AVE.		F.A. RT.	SECTION	COUNTY	TOTAL SHEETS	SHEET NO.	
S:\Project\107-0007-51-70\plan\crossect\17.dwg		DRAWN - LEC	REVISED -		SCALE: 1"=10'	SHEET NO. 17 OF 43 SHEETS	STA. 48+86.16 TO STA. 48+97.82	57/70	(25-3)I-6	EFFINGHAM	839	386
		CHECKED - BRM	REVISED -									
		DATE - 11-05-07	REVISED -									
							FED. ROAD DIST. NO. ILLINOIS FED. AID PROJECT					

FINAL SURVEY	DATE
SURVEYED	
PLOTTED	
NOTE BOOK	
AREAS CHECKED	
NO.	

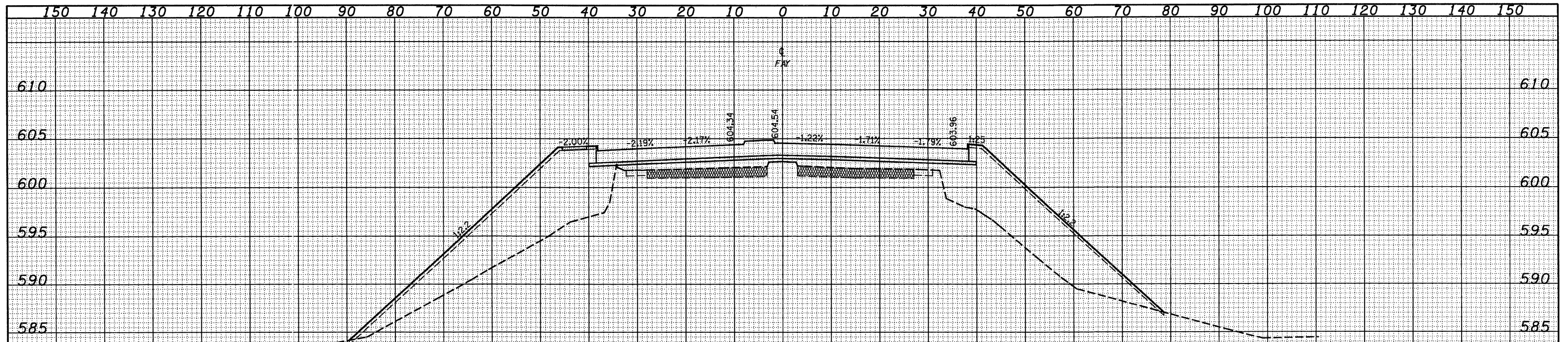

51 + 20.79
SKewed 12.60°
NOT FOR EARTHWORK

ORIGINAL SURVEY	DATE
SURVEYED	
PLOTTED	
NOTE BOOK	
AREAS CHECKED	
NO.	

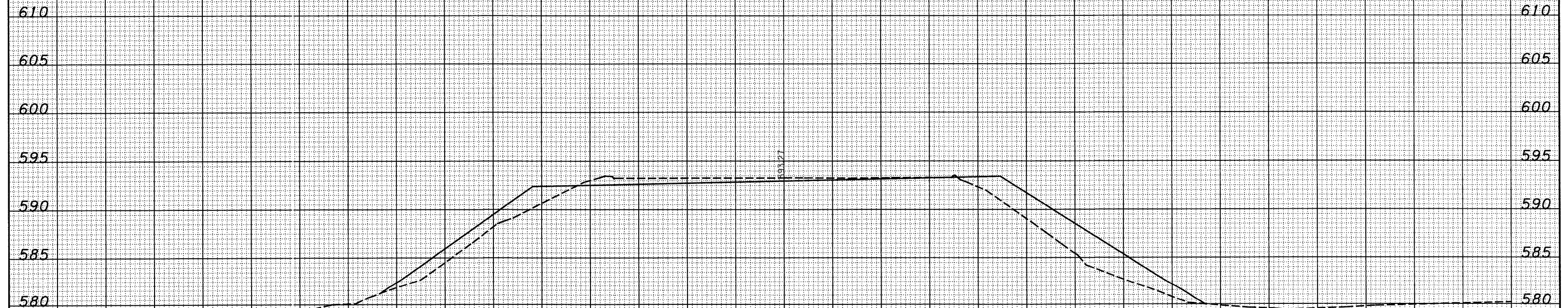

GRADING OMISSION FROM STA 48+97.82 TO STA 51+02.75
 SEE MAINLINE MOT CROSS SECTIONS FOR EARTHWORK

51 + 02.75
SKewed 12.60°
NOT FOR EARTHWORK

DATE	
BY	
SURVEYED	
PLOTTED	
NOTE BOOK	
AREAS CHECKED	
NO.	

DATE	
BY	
SURVEYED	
PLOTTED	
NOTE BOOK	
AREAS CHECKED	
NO.	

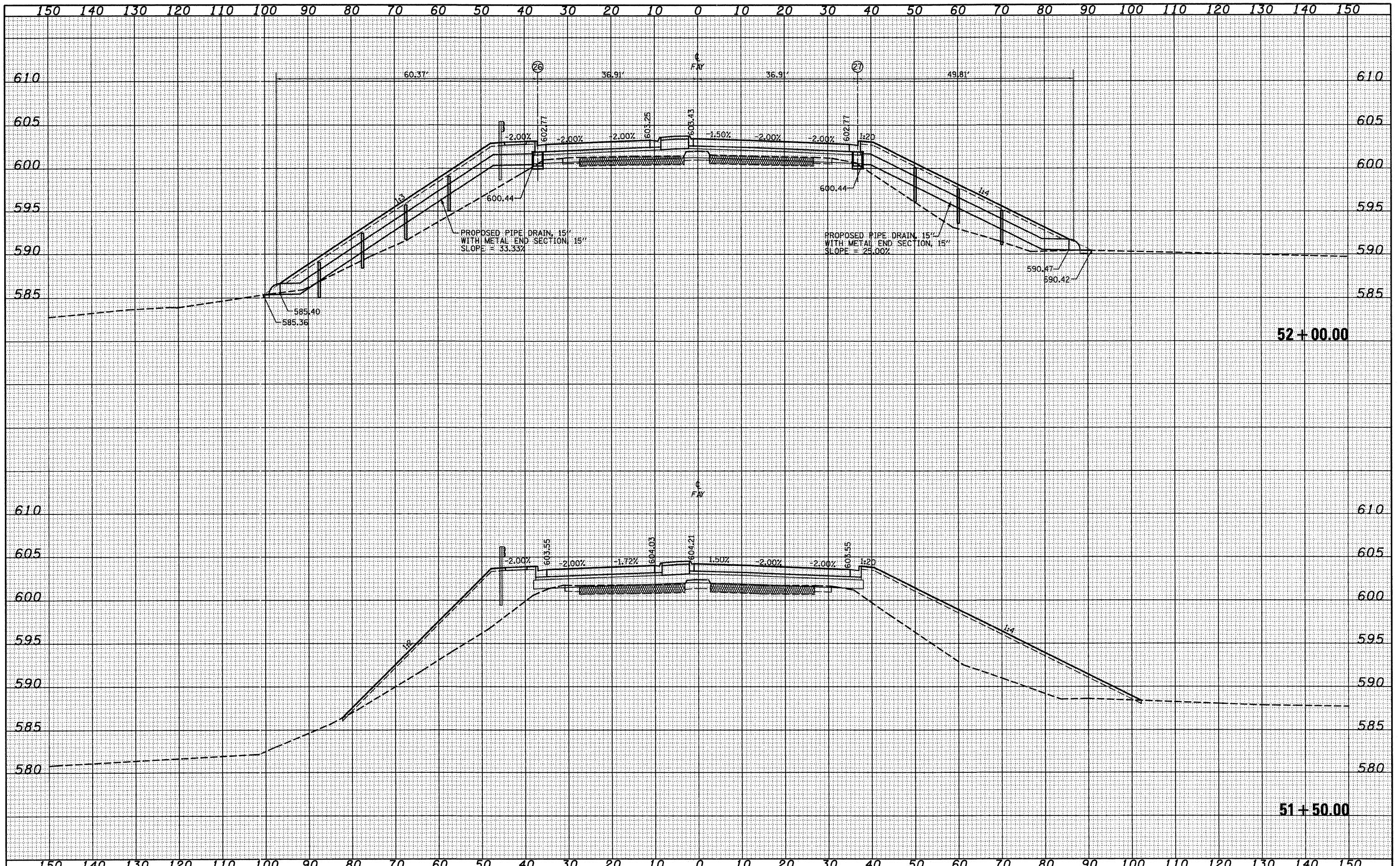

FILE NAME =	USER NAME = lnda	DESIGNED - JWS	REVISED -	STATE OF ILLINOIS DEPARTMENT OF TRANSPORTATION	CROSS SECTIONS, FAYETTE AVE.			F.A. RT.	SECTION	COUNTY	TOTAL SHEETS	SHEET NO.
S:\Projects\102-0007-57-70.dgn\Fayette\cross1.dgn		DRAWN - LEC	REVISED -		57/70	(25-3)I-6	EFFINGHAM	839	388			
PLOT SCALE = 20.0000' / IN.		CHECKED - BRM	REVISED -		SCALE: 1"=10'	SHEET NO. 19 OF 43 SHEETS	STA. 51+50.00 TO STA. 52+00.00	CONTRACT NO. 74293				
PLOT DATE = 6/24/2010		DATE - 11-05-07	REVISED -		FED. ROAD DIST. NO.		ILLINOIS FED. AID PROJECT					

DATE	
BY	
SURVEYED	
TEMPERATURE	
NOTE BOOK	
AREAS CHECKED	
NO.	

DATE	
BY	
SURVEYED	
TEMPERATURE	
NOTE BOOK	
AREAS CHECKED	
NO.	

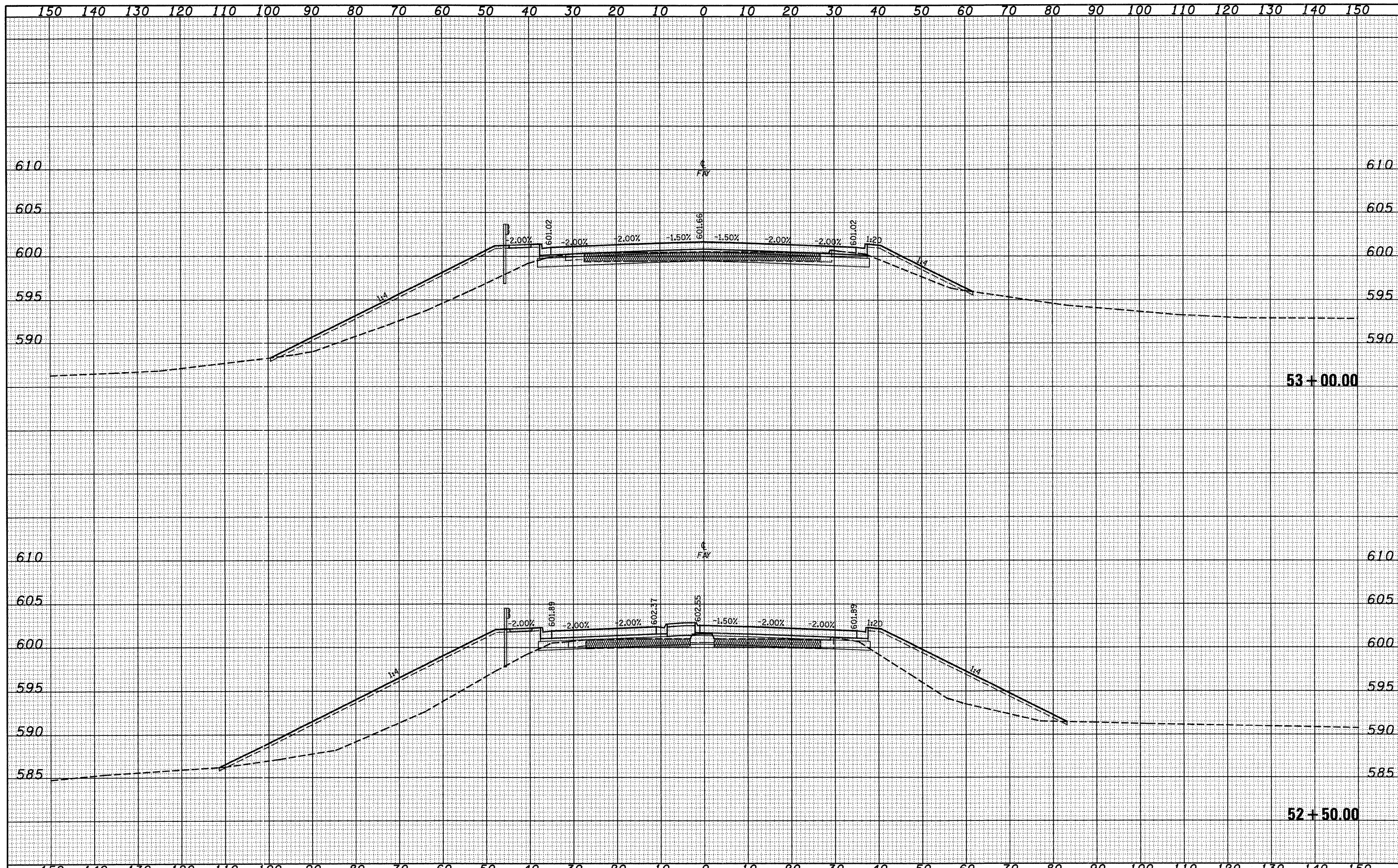

FILE NAME -	USER NAME = llrnda	DESIGNED - JWS	REVISED -	STATE OF ILLINOIS DEPARTMENT OF TRANSPORTATION	CROSS SECTIONS, FAYETTE AVE.		F.A. RT.	SECTION	COUNTY	TOTAL SHEETS	SHEET NO.
S:\Projects\103-800\7-57-70.dwg\Fayette\cross1.dwg		DRAWN - LEC	REVISED -		57/70	(25-3)-6	EFFINGHAM	839	389		
		CHECKED - BRM	REVISED -		SCALE: 1"=10'	SHEET NO. 20 OF 43 SHEETS	STA. 52+50.00 TO STA. 53+00.00	CONTRACT NO. 74293			
		DATE - 11-05-07	REVISED -		FED. ROAD DIST. NO.		ILLINOIS FED. AID PROJECT				

FINAL SURVEY	DATE
SURVEYED	BY
PLOTTED	
NOTE BOOK	
AREAS CHECKED	
NO.	

ORIGINAL SURVEY	DATE
SURVEYED	BY
PLOTTED	
NOTE BOOK	
AREAS CHECKED	
NO.	

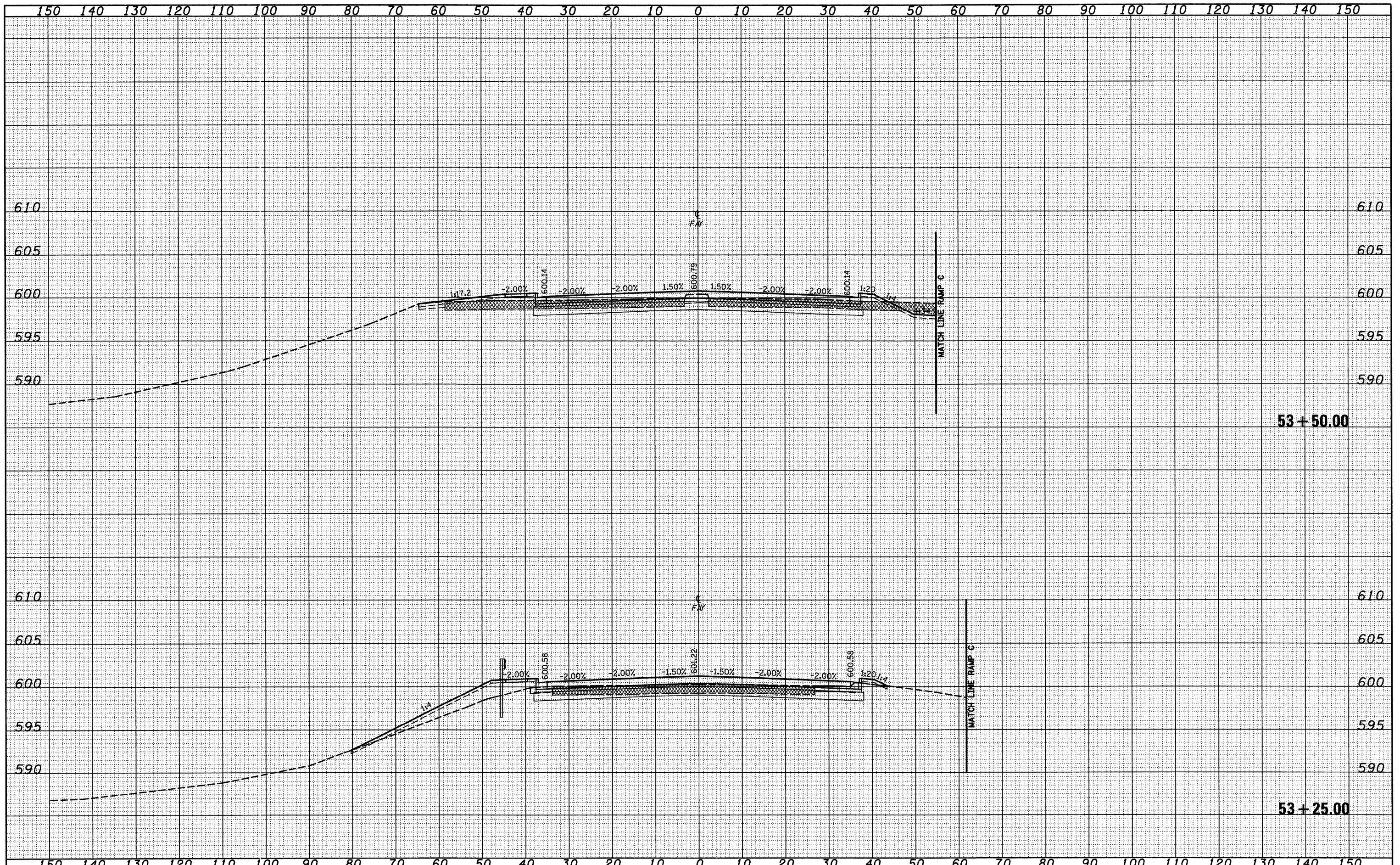

FILE NAME = S:\Projects\103-8007-51-70.dgn\Fayette\cross1.dgn
 USER NAME = linda

DESIGNED - JWS
 DRAWN - LEC
 CHECKED - BRM
 DATE - 11-05-07

REVISED -
 REVISED -
 REVISED -
 REVISED -

**STATE OF ILLINOIS
 DEPARTMENT OF TRANSPORTATION**

CROSS SECTIONS, FAYETTE AVE.

SCALE: 1"=10' SHEET NO. 21 OF 43 SHEETS STA. 53+25.00 TO STA. 53+50.00

F.A. RT.	SECTION	COUNTY	TOTAL SHEETS	SHEET NO.
57/70	(25-3)I-6	EFFINGHAM	839	390
FED. ROAD DIST. NO.			ILLINOIS FED. AID PROJECT	
			CONTRACT NO. 74293	

DATE	
BY	
FINAL SURVEY	
NO. TO BOOK	
NO.	

DATE	
BY	
ORIGINAL SURVEY	
NO. TO BOOK	
NO.	

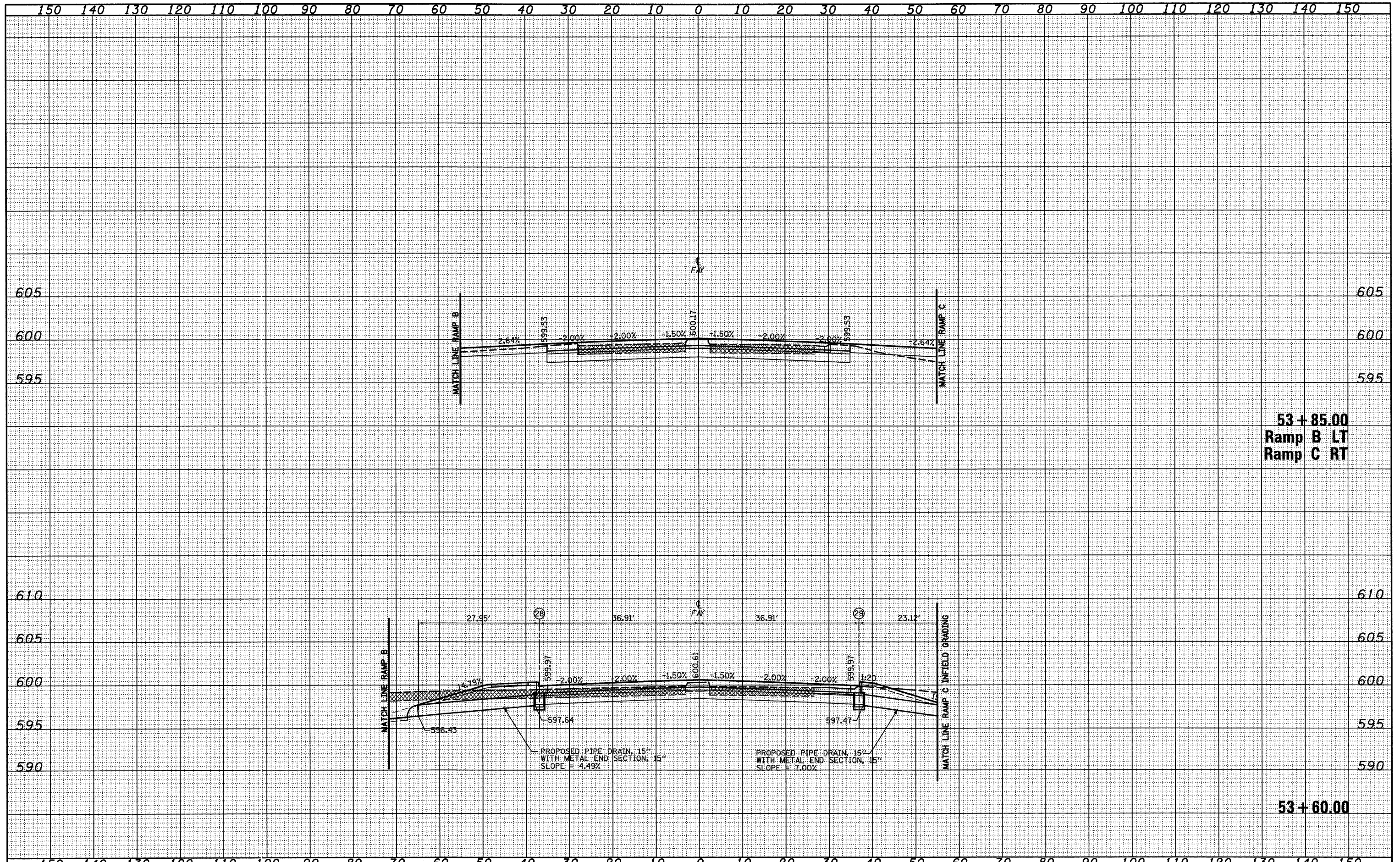

53+85.00
Ramp B LT
Ramp C RT

53+60.00

FILE NAME =	USER NAME = linda	DESIGNED - JWS	REVISED -	STATE OF ILLINOIS DEPARTMENT OF TRANSPORTATION	CROSS SECTIONS, FAYETTE AVE.			F.A. RT.	SECTION	COUNTY	TOTAL SHEETS	SHEET NO.
S:\Projects\183-0007-57-70.dgn\Fayette\sect18.dgn		DRAWN - LEC	REVISED -		57/70	(25-3)-6	EFFINGHAM	839	391			
PLOT SCALE = 20.0000' / IN.		CHECKED - BRM	REVISED -		SCALE: 1"=10'	SHEET NO. 22 OF 43 SHEETS	STA. 53+60.00 TO STA. 53+85.00	CONTRACT NO. 74293				
PLOT DATE = 6/24/2018		DATE - 11-05-07	REVISED -					ILLINOIS FED. AID PROJECT				

DATE	
BY	
FINAL SURVEY	
REVISION	
NOTE BOOK	
NO.	
AREAS CHECKED	

DATE	
BY	
ORIGINAL SURVEY	
REVISION	
NOTE BOOK	
NO.	
AREAS CHECKED	

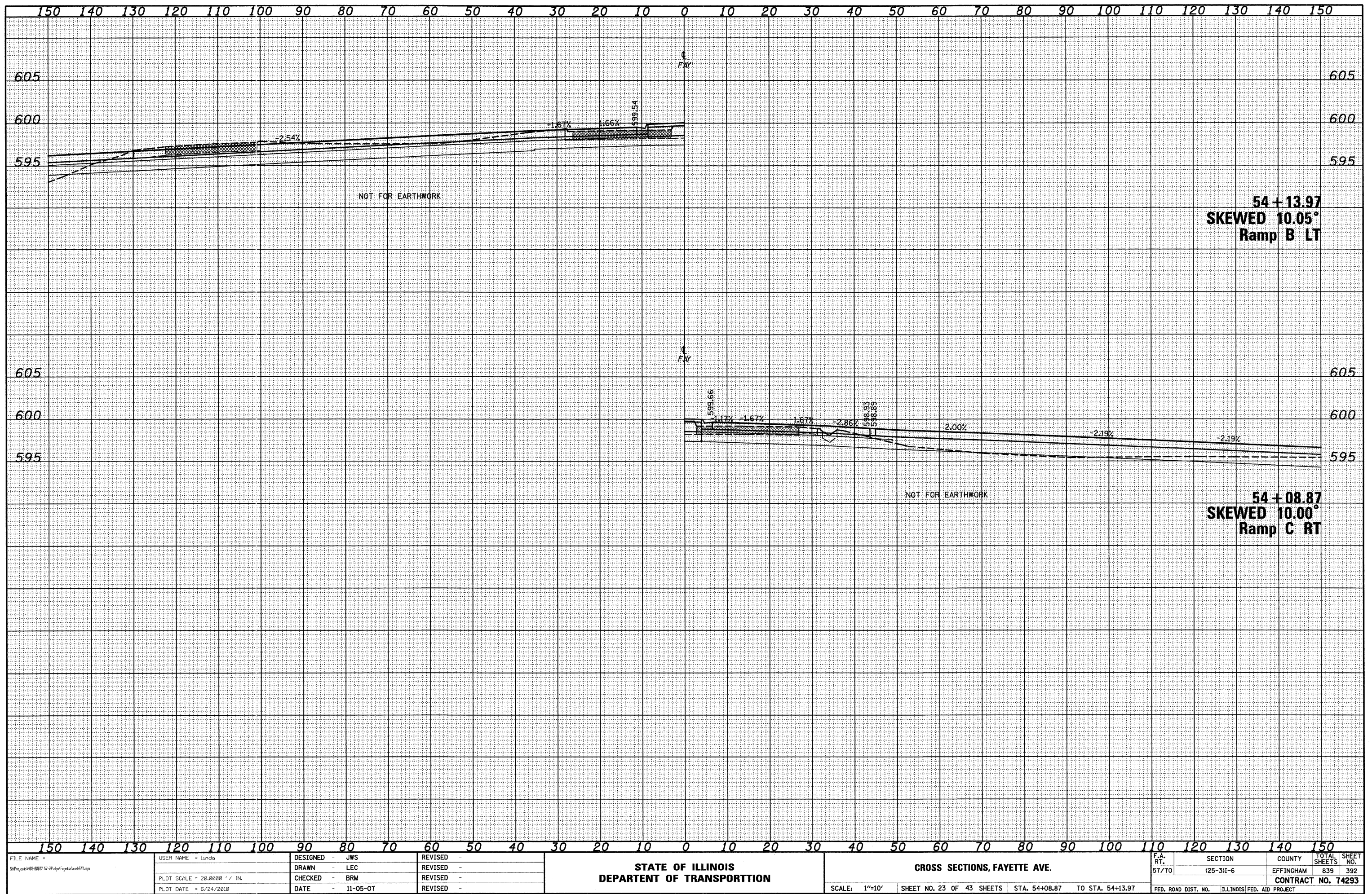

FILE NAME = S:\Projects\MD-607251\70.dgn
 USER NAME = linda
 DESIGNED - JWS
 DRAWN - LEC
 CHECKED - BRM
 DATE - 11-05-07
 PLOT SCALE = 20,00000' / IN.
 PLOT DATE = 6/24/2010

DESIGNED	- JWS	REVISED	-
DRAWN	- LEC	REVISED	-
CHECKED	- BRM	REVISED	-
DATE	- 11-05-07	REVISED	-

**STATE OF ILLINOIS
 DEPARTMENT OF TRANSPORTATION**

CROSS SECTIONS, FAYETTE AVE.
 SCALE: 1"=10'
 SHEET NO. 23 OF 43 SHEETS
 STA. 54+08.87 TO STA. 54+13.97

F.A. RT.	SECTION	COUNTY	TOTAL SHEETS	SHEET NO.
57/70	(25-3)-6	EFFINGHAM	839	392
FED. ROAD DIST. NO.		ILLINOIS FED. AID PROJECT		
		CONTRACT NO. 74293		

DATE	
BY	
SURVEYED	
FINAL SURVEY	
NOTE BOOK	
NO.	
TEMPLATE	
AREAS CHECKED	

DATE	
BY	
SURVEYED	
ORIGINAL SURVEY	
NOTE BOOK	
NO.	
TEMPLATE	
AREAS CHECKED	

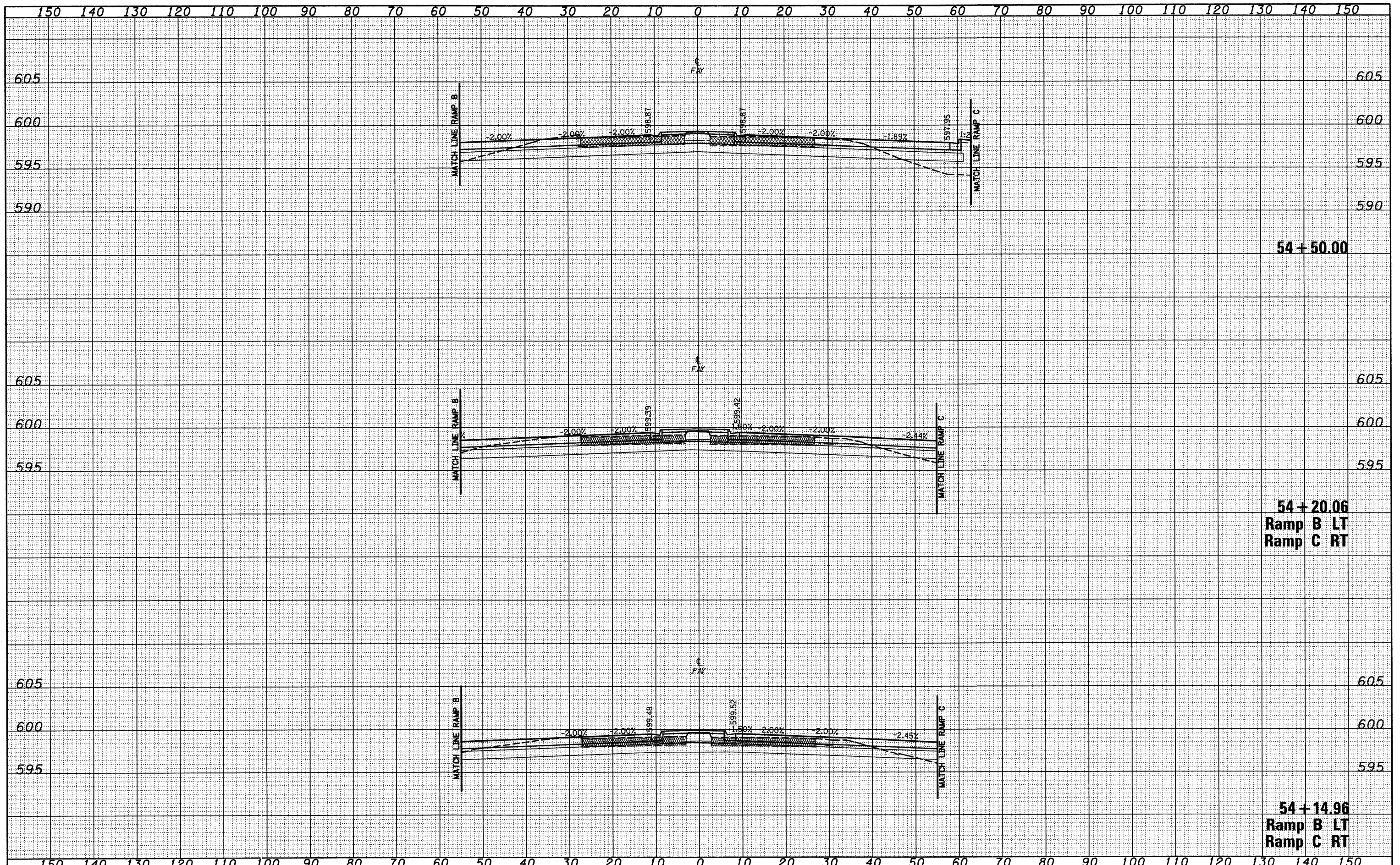

FILE NAME = S:\Projects\102\102-57-70.dgn\Fayette\cross1.dgn	USER NAME = l1nda	DESIGNED - JWS	REVISED -	STATE OF ILLINOIS DEPARTMENT OF TRANSPORTATION	CROSS SECTIONS, FAYETTE AVE.			F.A. RT. 57/70	SECTION (25-3)I-6	COUNTY EFFINGHAM	TOTAL SHEETS 839	SHEET NO. 393	
PLOT SCALE = 20.0000' / IN.		CHECKED - BRM	REVISED -		SCALE: 1"=10'	SHEET NO. 24 OF 43 SHEETS	STA. 54+14.96 TO STA. 54+50.00	CONTRACT NO. 74293		ILLINOIS FED. AID PROJECT			
PLOT DATE = 6/24/2010		DATE - 11-05-07	REVISED -										

DATE	
BY	
SURVEYED	
NOTE BOOK	
TEMP. PLATE	
AREAS CHECKED	
NO.	

DATE	
BY	
ORIGINAL SURVEY	
NOTE BOOK	
TEMP. PLATE	
AREAS CHECKED	
NO.	

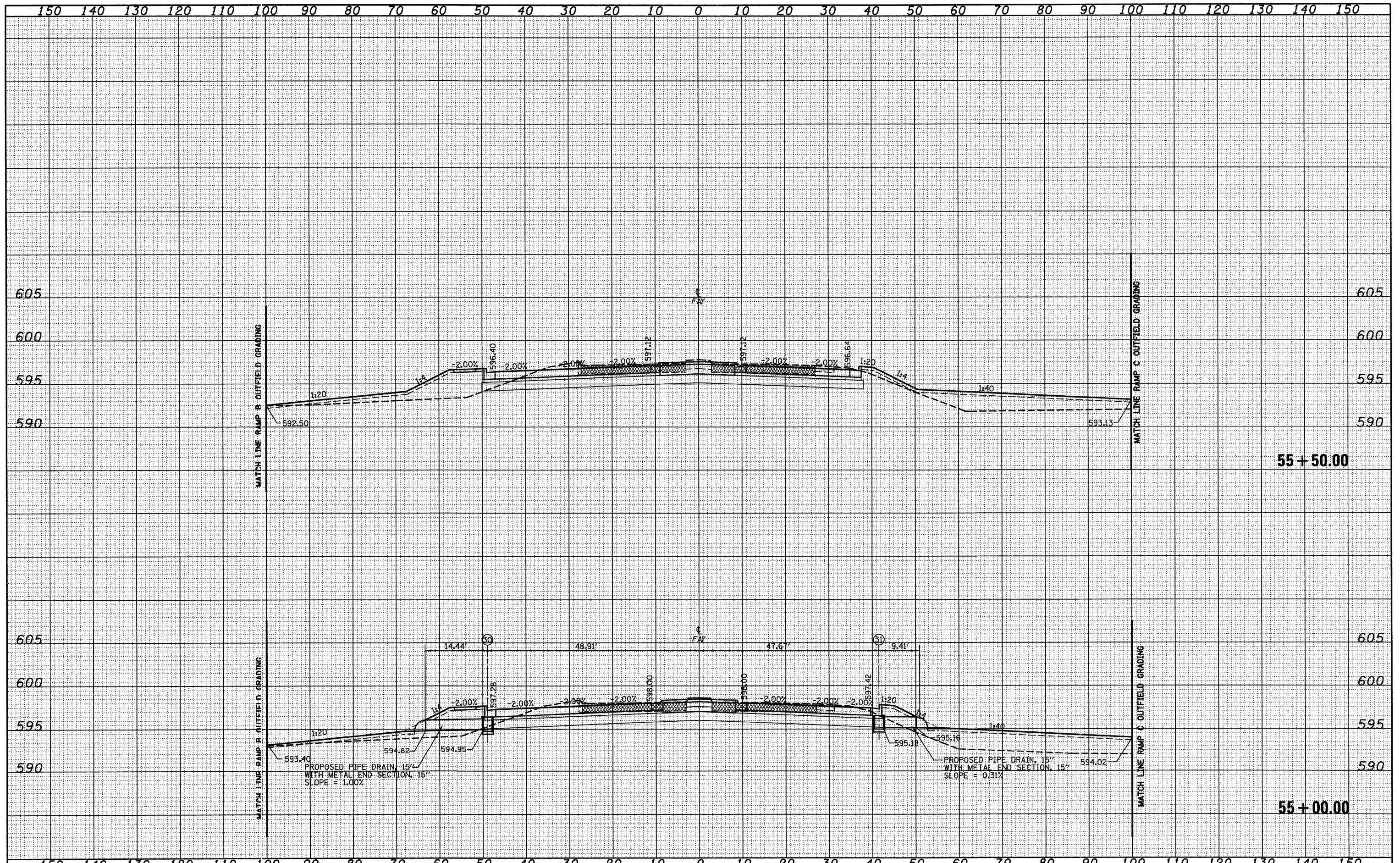

FILE NAME =	USER NAME = lunda	DESIGNED - JWS	REVISED -	STATE OF ILLINOIS DEPARTMENT OF TRANSPORTATION	CROSS SECTIONS, FAYETTE AVE.		F.A. RT.	SECTION	COUNTY	TOTAL SHEETS	SHEET NO.	
S:\Projects\103-0007\57-70\Drawings\Fayette\crossRt.dwg		DRAWN - LEC	REVISED -		SCALE: 1"=10'	SHEET NO. 25 OF 43 SHEETS	STA. 55+00.00 TO STA. 55+50.00	57/70	(25-3)-6	EFFINGHAM	839	394
		CHECKED - BRM	REVISED -									
		DATE - 11-05-07	REVISED -					FED. ROAD DIST. NO.	ILLINOIS FED. AID PROJECT			CONTRACT NO. 74293

DATE	
BY	
FINAL SURVEY	
NO. OF SHEETS	
NOTE BOOK	
NO.	

DATE	
BY	
ORIGINAL SURVEY	
NO. OF SHEETS	
NOTE BOOK	
NO.	

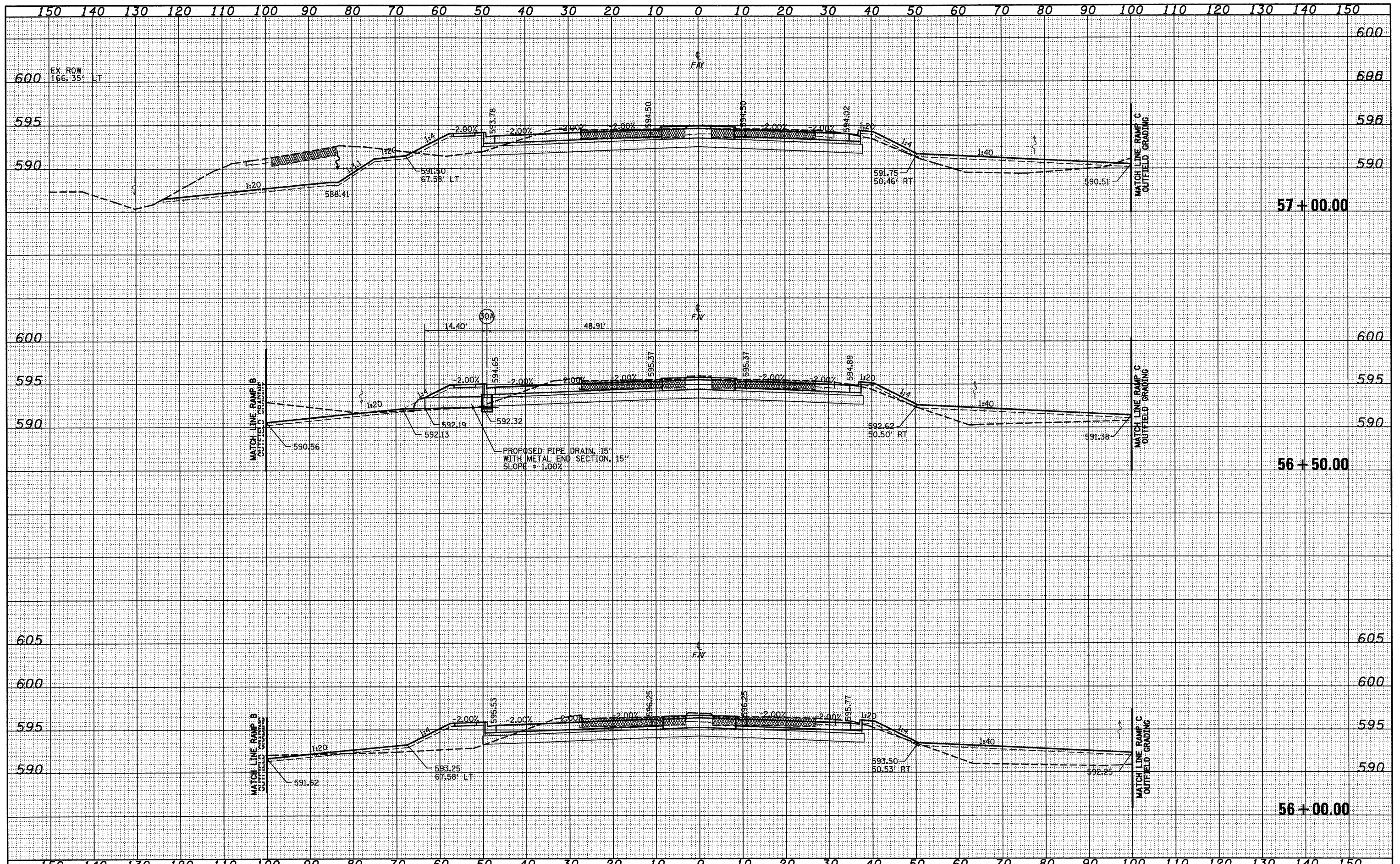

FILE NAME =	USER NAME = Junda	DESIGNED - JWS	REVISED -	STATE OF ILLINOIS DEPARTMENT OF TRANSPORTATION	CROSS SECTIONS, FAYETTE AVE. F.A. RT. SECTION COUNTY TOTAL SHEETS SHEET NO. 57/70 (25-3)I-6 EFFINGHAM 839 395 CONTRACT NO. 74293					
PLOT SCALE = 20.0000' / IN.	CHECKED - BRM	REVISIED -	REVISIED -							
PLOT DATE = 6/24/2018	DATE - 11-05-07	REVISIED -	REVISIED -							
SCALE: 1"=10'					SHEET NO. 26 OF 43 SHEETS		STA. 56+00.00 TO STA. 57+00.00		FED. ROAD DIST. NO. ILLINOIS FED. AID PROJECT	

DATE	
BY	
SURVEYED	
NOTED	
TEMPLATE	
AREAS CHECKED	
FINAL SURVEY	
NOTE BOOK	
NO.	

DATE	
BY	
SURVEYED	
NOTED	
TEMPLATE	
AREAS CHECKED	
ORIGINAL SURVEY	
NOTE BOOK	
NO.	

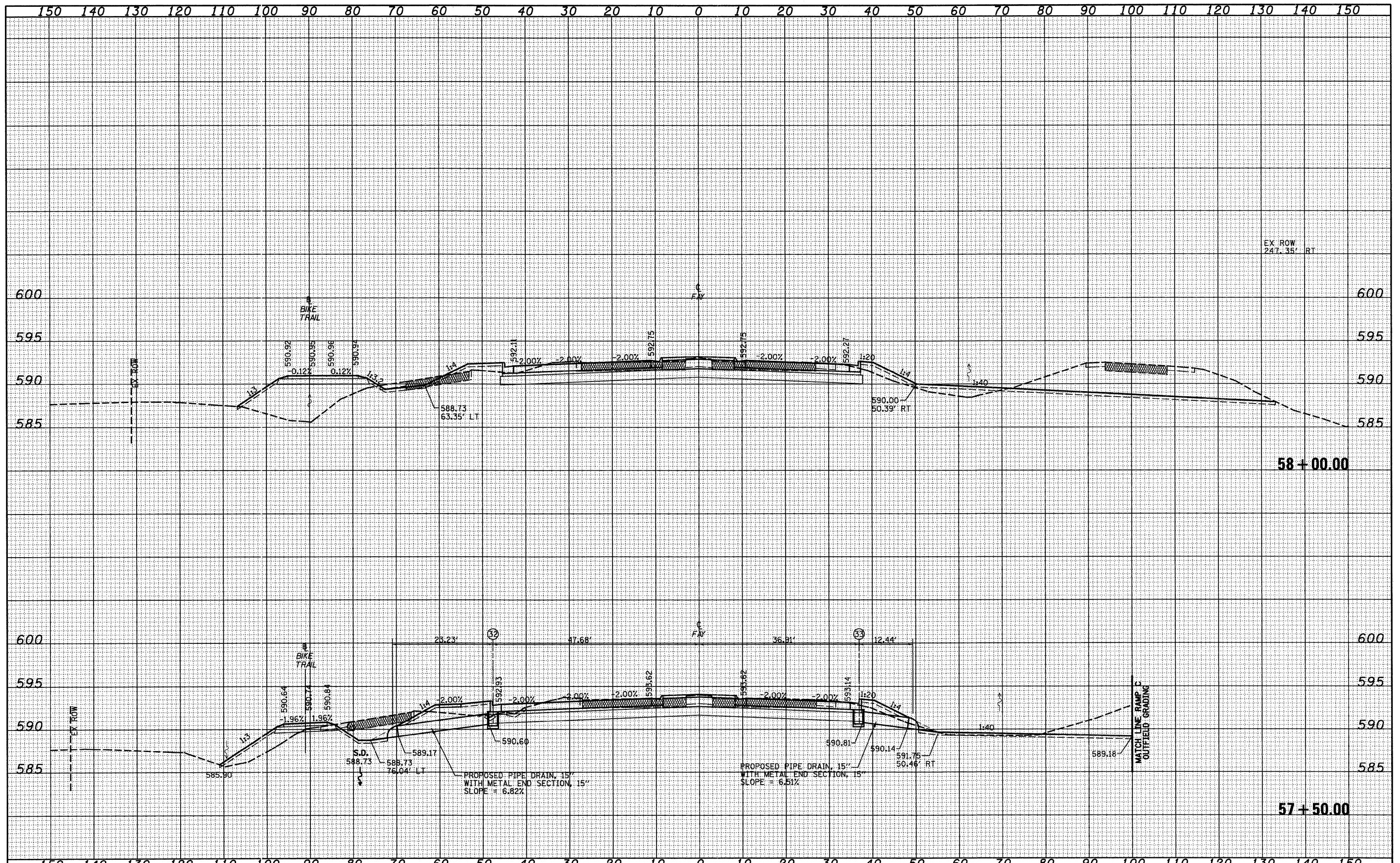

FILE NAME =	USER NAME = lards	DESIGNED - JWS	REVISED -	STATE OF ILLINOIS DEPARTMENT OF TRANSPORTATION	CROSS SECTIONS, FAYETTE AVE. SCALE: 1"=10' SHEET NO. 27 OF 43 SHEETS STA. 57+50.00 TO STA. 58+00.00		F.A. RT.	SECTION	COUNTY	TOTAL SHEETS	SHEET NO.
S:\projects\103\103-000\757-70.dgn\FayetteAve.dgn	PLOT SCALE = 20.00000' / IN.	DRAWN - LEC	REVISED -				57/70	(25-3)-6	EFFINGHAM	839	396
PLOT DATE = 6/24/2010	DATE - 11-05-07	CHECKED - BRM	REVISED -				CONTRACT NO. 74293				
		DATE - 11-05-07	REVISED -				ILLINOIS FED. AID PROJECT				

DATE	
BY	
FINAL SURVEY	
SURVEYED	
NOTE BOOK	
TEMPLATE	
AREAS CHECKED	
NO.	

DATE	
BY	
ORIGINAL SURVEY	
SURVEYED	
NOTE BOOK	
TEMPLATE	
AREAS CHECKED	
NO.	

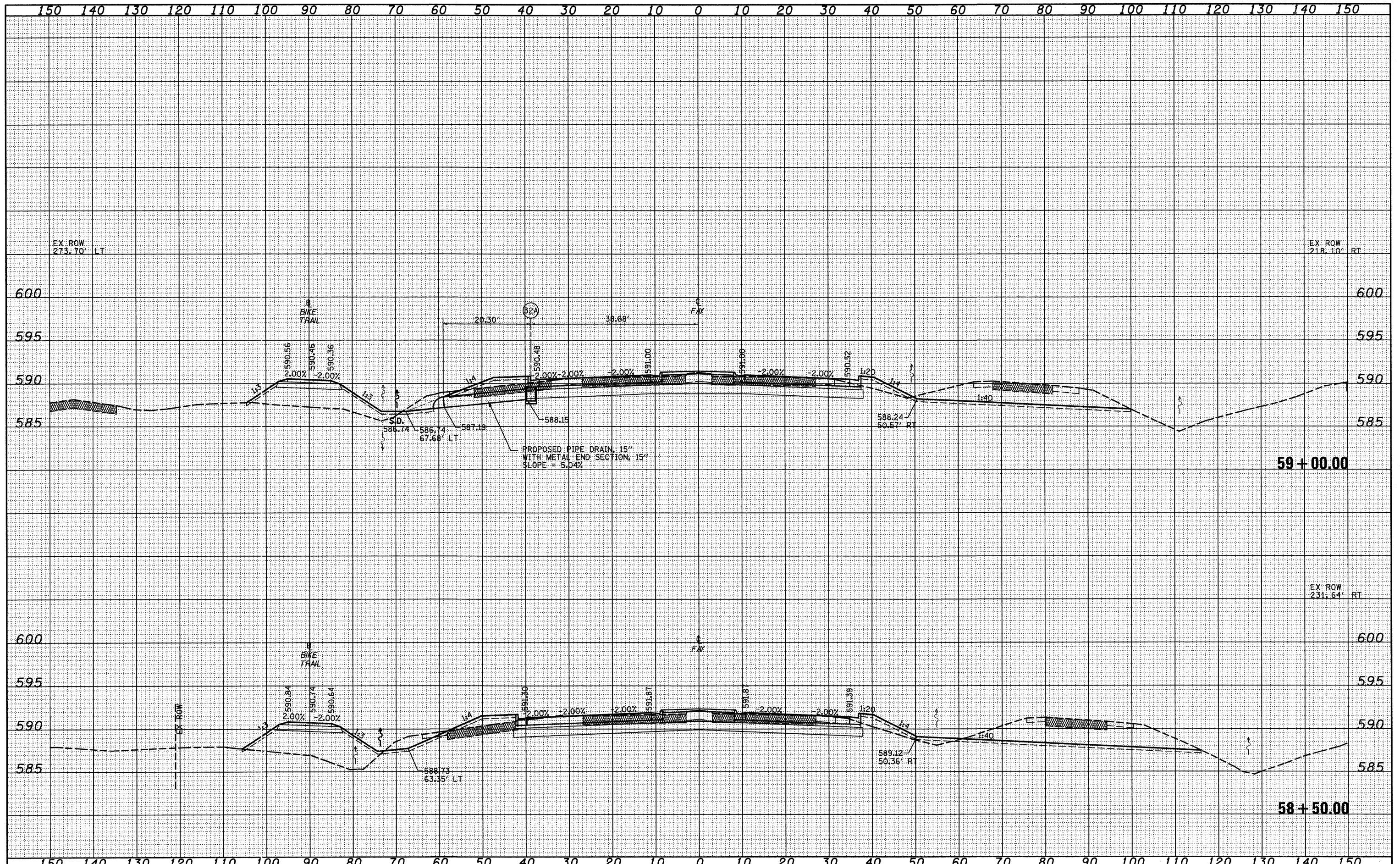

DATE	
BY	
FINAL SURVEY	
SURVEYED	
PLOTTED	
NOTE BOOK	
AREAS CHECKED	
NO.	

DATE	
BY	
ORIGINAL SURVEY	
SURVEYED	
PLOTTED	
NOTE BOOK	
AREAS CHECKED	
NO.	

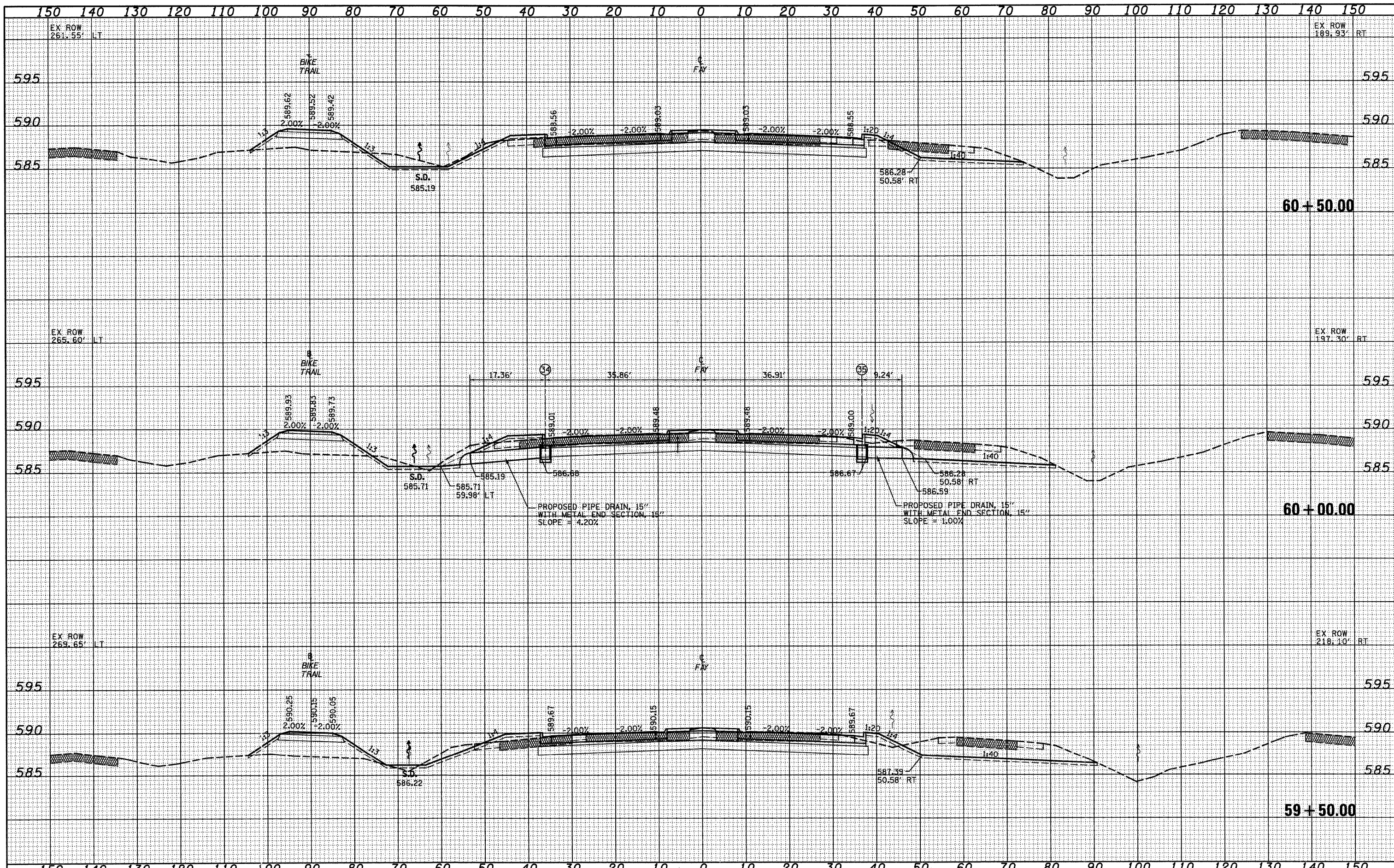

DATE _____
 BY _____
 SURVEYED _____
 PLOTTED _____
 NOTE BOOK _____
 AREAS CHECKED _____
 NO. _____

DATE _____
 BY _____
 ORIGINAL SURVEY _____
 PLOTTED _____
 NOTE BOOK _____
 AREAS CHECKED _____
 NO. _____

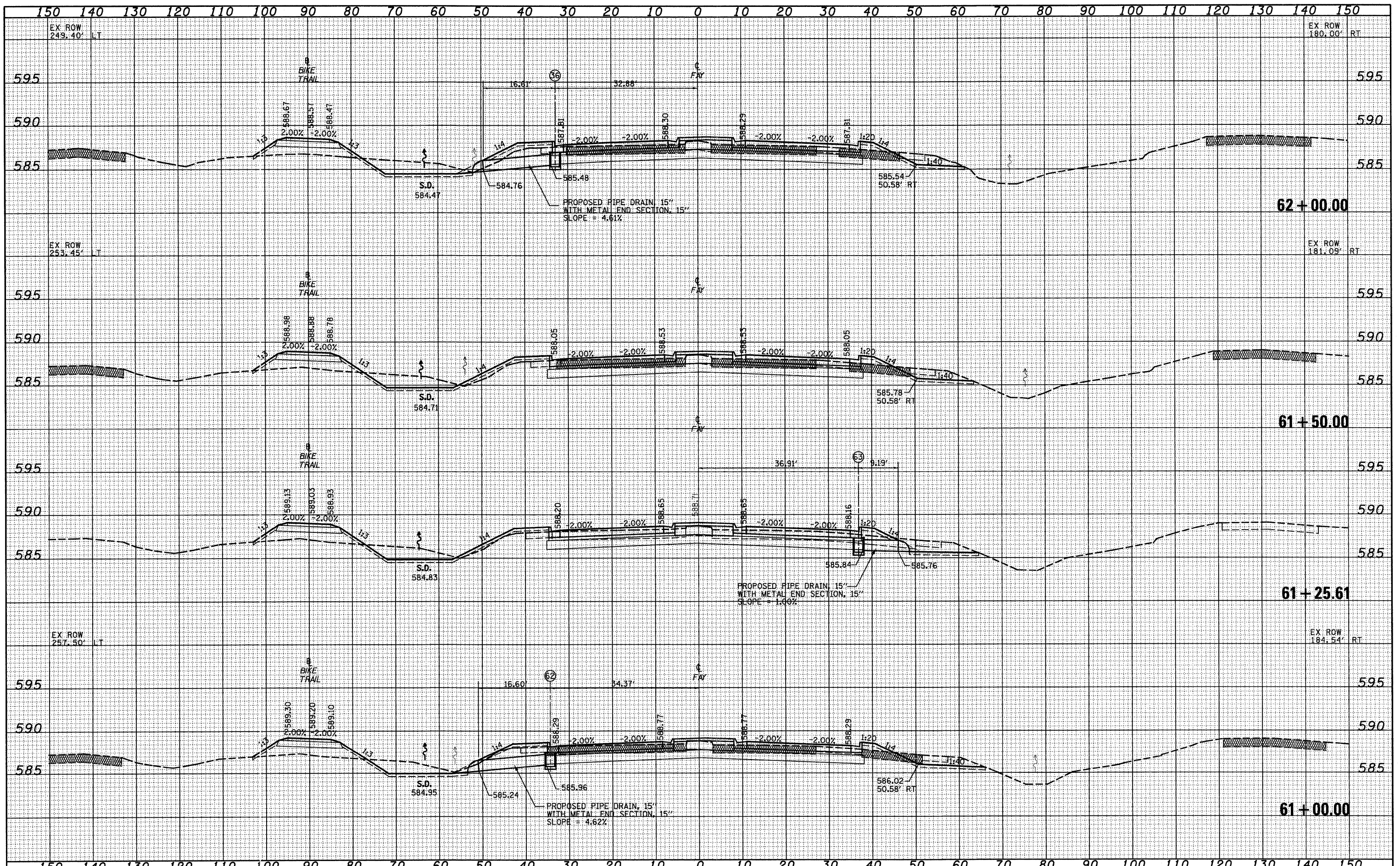

DATE _____
 BY _____
 SURVEYED _____
 PLOTTED _____
 NOTE BOOK _____
 AREAS CHECKED _____
 NO. _____

DATE _____
 BY _____
 SURVEYED _____
 PLOTTED _____
 NOTE BOOK _____
 AREAS CHECKED _____
 NO. _____

