

INDEX OF SHEETS

SHEET NO.	DESCRIPTION
1	TITLE SHEET & SUMMARY OF QUANTITIES
2	PLAN & PROFILE, TYPICAL SECTIONS, GENERAL NOTES & STONE RIPRAP DITCH DESIGN
3-4	ROADWAY CROSS SECTIONS
5-12	BRIDGE DESIGN

HIGHWAY STANDARDS

000001-05	STANDARD SYMBOLS, ABBREVIATIONS & PATTERNS (8 SHEETS)
280001-05	TEMPORARY EROSION CONTROL SYSTEMS (2 SHEETS)
515001-03	NAME PLATE FOR BRIDGES (2 SHEETS)
542401-01	METAL END SECTION FOR PIPE CULVERTS
701901-01	TRAFFIC CONTROL DEVICES (3 SHEETS)
B.L.R. 21-B	TYPICAL APPLICATION OF TRAFFIC CONTROL DEVICES FOR CONSTRUCTION ON RURAL LOCAL HIGHWAYS
B.L.R. 22-6	TYPICAL APPLICATION OF TRAFFIC CONTROL DEVICES FOR CONSTRUCTION ON RURAL LOCAL HIGHWAYS (TWO-LANE TWO-WAY RURAL TRAFFIC) (ROAD CLOSED TO THRU TRAFFIC)

SUMMARY OF QUANTITIES

QUANTITY	UNIT	ITEM	CODE NO.
35.00	UNIT	TREE REMOVAL (6 TO 15 UNITS DIAMETER)	20100110
74.00	UNIT	TREE REMOVAL (OVER 15 UNITS DIAMETER)	20100210
392.00	CU YD	EARTH EXCAVATION	20200100
171.00	CU YD	CHANNEL EXCAVATION	20300100
752.00	CU YD	FURNISHED EXCAVATION	20400800
0.40	ACRE	SEEDING, CLASS 2 (SPECIAL)	X2501000
18.00	FOOT	TEMPORARY DITCH CHECKS	28000305
13.00	TON	AGGREGATE (EROSION CONTROL)	28001000
615.00	TON	STONE DUMPED RIPRAP, CLASS A4	28100807
400.00	TON	AGGREGATE SURFACE COURSE, TYPE B	40200800
1.00	EACH	REMOVAL OF EXISTING STRUCTURES	50100100
23.80	CU YD	CONCRETE STRUCTURES	50300225
2.80	CU YD	CONCRETE ENCASEMENT	50300280
1320.00	SQ FT	PRECAST PRESTRESSED CONCRETE DECK BEAMS (21" DEPTH)	50400405
2560.00	POUND	REINFORCEMENT BARS	50800105
106.00	FOOT	STEEL RAILING, TYPE S1	50900205*
240.00	FOOT	FURNISHING STEEL PILES HP10X42	51201400
240.00	FOOT	DRIVING PILES	51202305
1.00	EACH	NAME PLATES	51500100
48.00	FOOT	PIPE CULVERTS, CLASS C, TYPE 1 36"	54200241
2.00	EACH	ALUMINUM END SECTIONS 36"	54214101
1.00	L SUM	MOBILIZATION	67101100

* SPECIALTY ITEMS

DESIGN DESIGNATION:
DESIGN SPEED: 30 MPH
HIGHWAY CLASS - LOCAL ROAD
EXISTING STRUCTURE NO.: 024-3064
PROPOSED STRUCTURE NO.: 024-3138
CURRENT A.D.T. = 50
CONTRACT NO. 95633

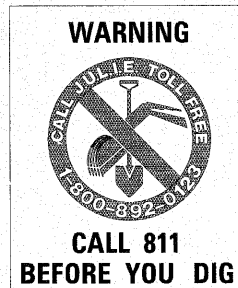

STATE OF ILLINOIS

DEPARTMENT OF TRANSPORTATION

**PLANS FOR PROPOSED
FEDERAL AID - H.B.P. PROJECT**

T.R. 185 EDWARDS COUNTY SECTION 07-06115-00-BR

PROJ. NO. ARA-BROS-047(033) JOB NO. C-97-081-10

CONTRACT #95633 BUTTER CREEK

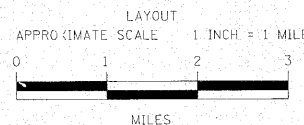
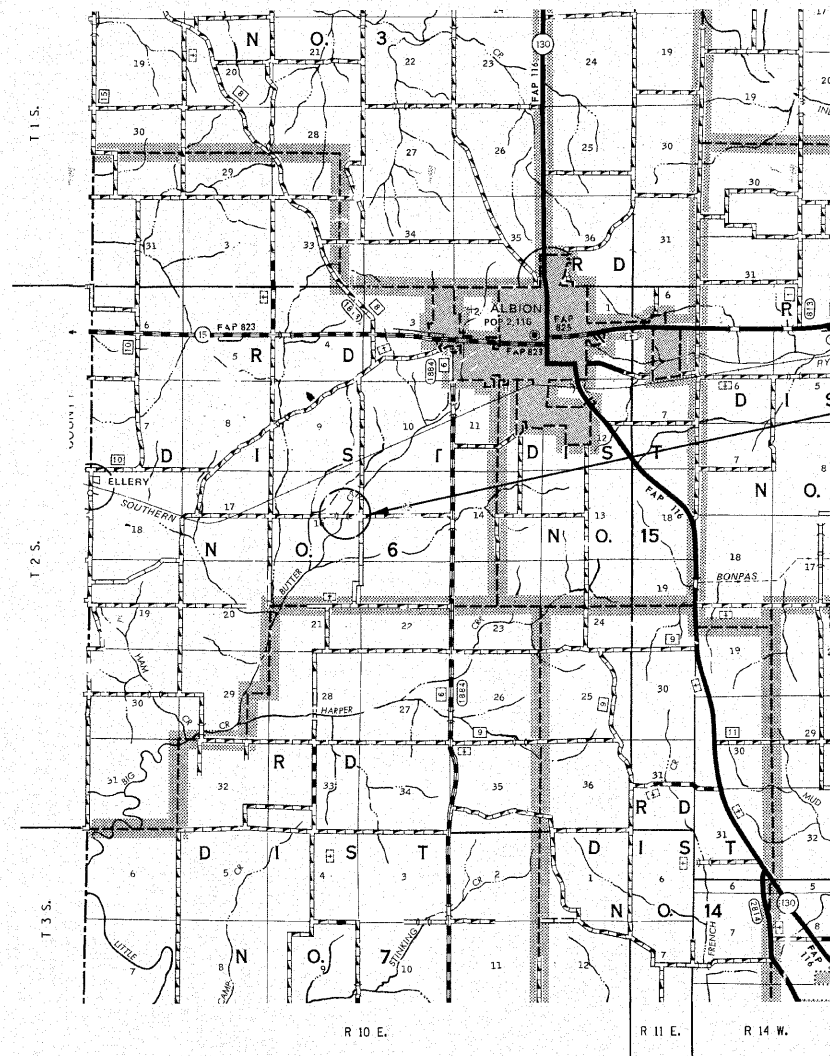

GROSS LENGTH	600.00 FT	0.114 MILES
OMISSIONS	0.00 FT	0.00 MILES
NET LENGTH	600.00 FT	0.114 MILES

SECTION 07-06115-00-BR
BEGINS STATION 2+00

STATION 5+00, STRUCTURE NO. 024-3138
A 55' LONG SINGLE SPAN PRECAST
PRESTRESSED CONCRETE DECK BEAM BRIDGE
(21" DEPTH), 24' ROADWAY, 20° LT. FWD. SKEW.

SECTION 07-06115-00-BR
ENDS STATION 8+00

PLAN	1" = 50'	
PROFILE	1" = 50'	
PROFILE VERT.	1" = 5'	

APPROVED 6-25 2010
[Signature]
COUNTY ENGINEER

PASSED 7-13 2010
[Signature]
DISTRICT SEVEN ENGINEER OF
LOCAL ROADS & STREETS

Releasing For
Bid Based on
Limited Review 7-13 2010
[Signature]
DEPUTY DIRECTOR OF HIGHWAYS,
REGION FOUR ENGINEER

STATE OF ILLINOIS
DEPARTMENT OF TRANSPORTATION

T.R.	SECTION	COUNTY	TOTAL SHEETS	SHEET NO.
185	07-06115-00-BR	EDWARDS	12	1

FED. ROAD DIST. NO. 7 ILLINOIS
FED. AID PROJECT
PROJ. NO. ARA-BROS-047(033)
CONTRACT # 95633
LEC JOB # H08L025ED
BUTTER CREEK

323 W. 3RD ST.
P.O. BOX 160
MT. CARMEL, IL
62863
PHONE:
(618)-262-8651
FAX:
(618)-263-3327

405 W. STATE ST.
SUITE 1
PRINCETON, IN
47570
PHONE:
(812)-386-7611
FAX:
(812)-385-2812



PROFESSIONAL DESIGN FIRM
LAND SURVEY &
PROFESSIONAL ENGINEERING
CORPORATION
184-000887
(62-032435)(35-002769)

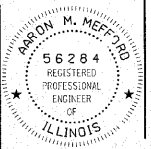

AARON M. MEFFORD
NAME
SIGNATURE *[Signature]*
DATE
6-25-10
11-30-11
EXPIRES

BUTTER CREEK
TOWNSHIP ROUTE 185
EDWARDS COUNTY, ILLINOIS

SHEET TITLE:
TITLE SHEET
SCALE: VARIES
B.Y.: AMM
DATE: 6/25/10
REV:
1 OF 12
SHEETS
SHEET NO.
1

GENERAL NOTES:

THIS SECTION SHALL BE CONSTRUCTED IN ACCORDANCE WITH THE PLANS, SPECIAL PROVISIONS AND "STANDARD SPECIFICATIONS FOR ROAD AND BRIDGE CONSTRUCTION", ADOPTED JANUARY 1, 2007.

THE WORK INVOLVED ON THIS SECTION CONSISTS OF THE REMOVAL OF THE EXISTING STRUCTURE, THE CONSTRUCTION OF A 55 FOOT LONG SINGLE SPAN PRECAST PRESTRESSED CONCRETE DECK BEAM BRIDGE, EARTH APPROACHES, AGGREGATE SURFACE COURSE AND OTHER MISCELLANEOUS ITEMS NECESSARY TO COMPLETE THIS SECTION.

ALL ELEVATIONS ARE BASED ON U.S.G.S. MEAN SEA LEVEL DATUM.

IT SHALL BE THE CONTRACTOR'S RESPONSIBILITY TO CONTACT ALL THE UTILITIES, AFFECTING THE PROJECT, PRIOR TO CONSTRUCTION.

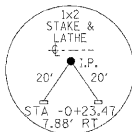

NOTE: CONSTRUCTION TRANSITIONS
 STA. 2+00 TO STA. 2+50
 STA. 7+50 TO STA. 8+00
 ALL QUANTITIES ARE INCLUDED IN THE PROPOSAL

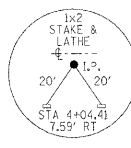

T.R.	SECTION	COUNTY	TOTAL SHEETS	SHEET NO.
185	07-06115-00-BR	EDWARDS	12	2
FED. ROAD DIST. NO. 7		ILLINOIS	BUTTER CREEK	
PROJECT: HARRIS-0470233		CONTRACT # 95633		
LEC JOB # H081025D				

323 W. 3RD ST.
 P.O. BOX 160
 MT. CARMEL, IL
 62863
 PHONE:
 (618)-262-8651
 FAX:
 (618)-263-3327

405 W. STATE ST
 SUITE 1
 PRINCETON, IN
 47670
 PHONE:
 (812)-386-7611
 FAX:
 (812)-385-2812



PROFESSIONAL DESIGN FIRM
 LAND SURVEY &
 PROFESSIONAL ENGINEERING CORPORATION
 184-030887
 (62-032435)(95-002769)

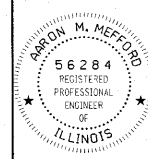

AARON M. MEFFORD
 NAME
 SIGNATURE
 DATE
 11-30-11
 EXPIRES

BUTTER CREEK
 TOWNSHIP ROUTE 185
 EDWARDS COUNTY, ILLINOIS

SHEET TITLE:

PLAN & PROFILE

SCALE: VPIES
 BY: AMM
 DATE: 6/25/10
 REV:

2 OF 12 SHEETS

SHEET NO. 2

TYPICAL CROSS SECTION PROPOSED

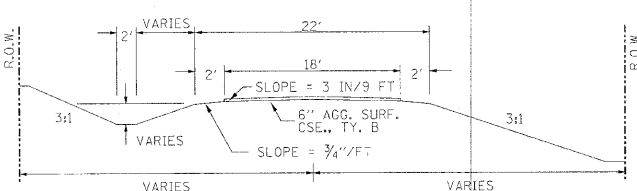

TYPICAL CROSS SECTION EXISTING

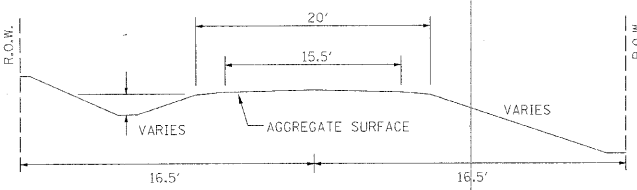

FIELD ENTRANCE DETAIL

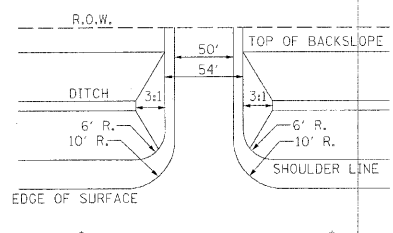

UTILITIES:
 J.U.L.L.E. 1-800-892-0123

NOTE: CONSTRUCT SPECIAL DITCH

- STA 2+00 TO STA 4+00 LT & RT
- STA 5+16 TO STA 6+81.7 RT
- STA 5+50 TO STA 7+29.5 LT
- STA 6+81.7 TO STA 8+00 RT
- STA 7+29.5 TO STA 8+00 LT

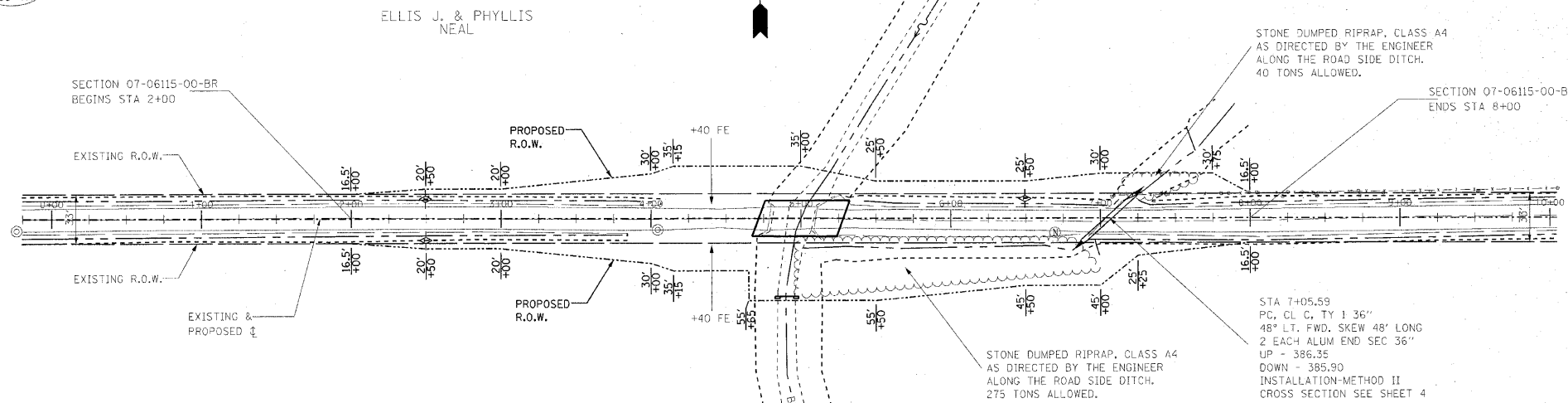

ELLIS J. & PHYLLIS NEAL

DANIEL & AMANDA METCALF

EXISTING BRIDGE STA 4+94.3; STRUCTURE NUMBER: 024-3064
 A 30' LONG SINGLE SPAN BRIDGE WITH 3" WOOD DECK WITH 2" WOOD RUNNERS ON 2-12" C-CHANNELS AND 6-12" I-BEAMS WITH 12" I-BEAM CAP ON 7-10" WOOD PILE AND STEEL PLATE MUD WALL ON EAST SIDE; CONCRETE MUD WALLS AND CONCRETE WINGWALLS ON WEST SIDE.

ONE (1) EACH-REMOVAL OF EXISTING STRUCTURES ALLOWED IN THIS PROPOSAL.

NOTE: FILL NEXT TO BRIDGE TO BE AGGREGATE SURFACE COURSE

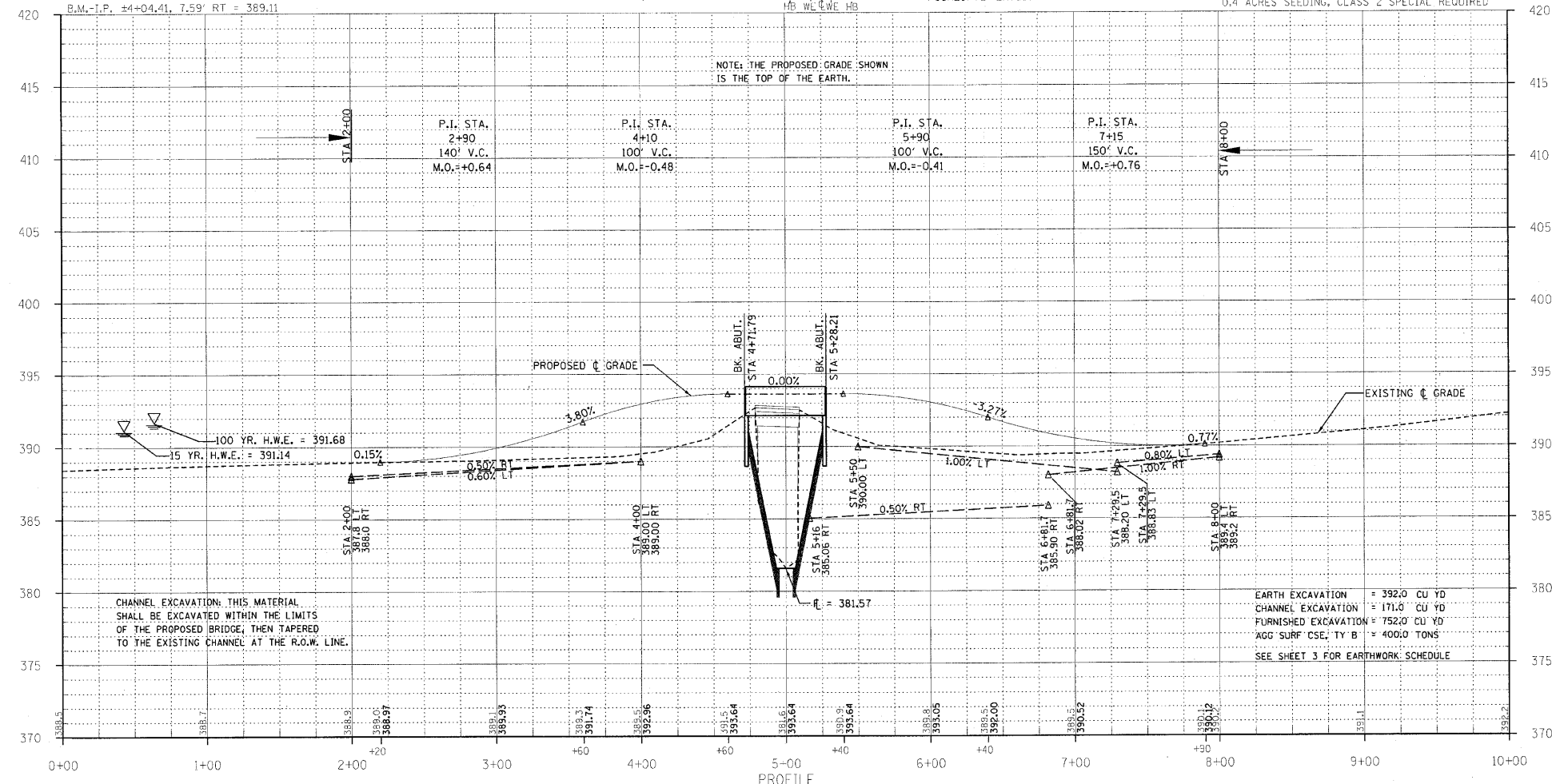

PROPOSED STRUCTURE: NO. 024-3138, STA 5+00,
 A 55' LONG SINGLE SPAN P.P.C.D.B. BRIDGE WITH 21" DEPTH BEAMS, SPILL THROUGH TYPE ABUTMENTS, 24' WIDTH, 0% GRADE, 20° LT FWD. SKEW.

SEE SHEETS 5-12 FOR THE DESIGN AND BILL OF MATERIALS.

- 35.0 UNIT TREE REMOVAL (6 TO 15 UNITS DIAMETER)
- 74.0 UNIT TREE REMOVAL (OVER 15 UNITS DIAMETER)
- 18.0 FOOT TEMPORARY DITCH CHECKS
- 13.0 TONS AGGREGATE (EROSION CONTROL)
- 0.4 ACRES SEEDING, CLASS 2 SPECIAL REQUIRED

T.R.	SECTION	COUNTY	TOTAL SHEETS	SHEET NO.
185	07-06115-00-BR	EDWARDS	12	3
FED. ROAD DIST. NO. 7 ILLINOIS		BUTTER CREEK		
PROJ. # MA BR05-04710331		CONTRACT # 95633		
LEC JOB # H081029ED				

323 W. 3RD ST.
P.O. BOX 160
MARIETTA, GA 30066
PHONE: (618)-262-8651
FAX: (618)-263-3327

405 W. STATE ST.
SUITE 1
PRINCETON, IN 47670
PHONE: (812)-386-7611
FAX: (812)-385-2812



PROFESSIONAL DESIGN FIRM
LAND SURVEY & PROFESSIONAL ENGINEERING CORPORATION
184-000887
(62-032435)(35-002769)

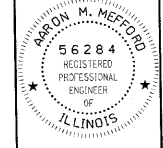

AARON M. MEFFORD
NAME
Aaron Mefford
SIGNATURE
DATE: 6-25-10
11-30-11 EXPIRES

BUTTER CREEK
TOWNSHIP ROUTE 185
EDWARDS COUNTY, ILLINOIS

SHEET TITLE:
CROSS-SECTIONS
SCALE: 1" = 5'
BY: AMM
DATE: 6/25/10
REV:
3 OF 12 SHEETS
SHEET NO. 3

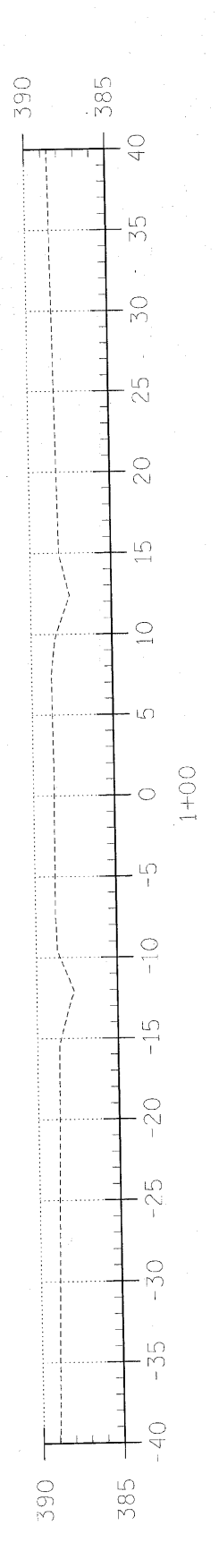
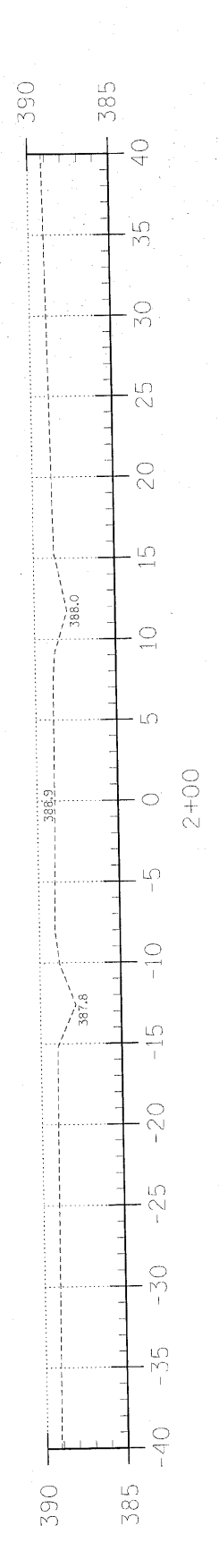
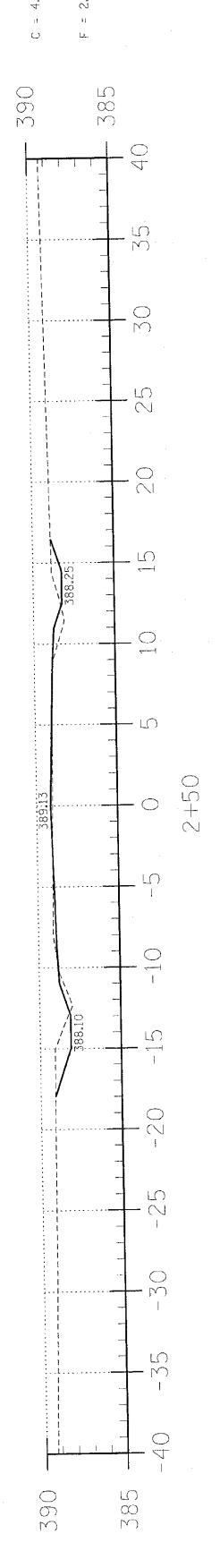
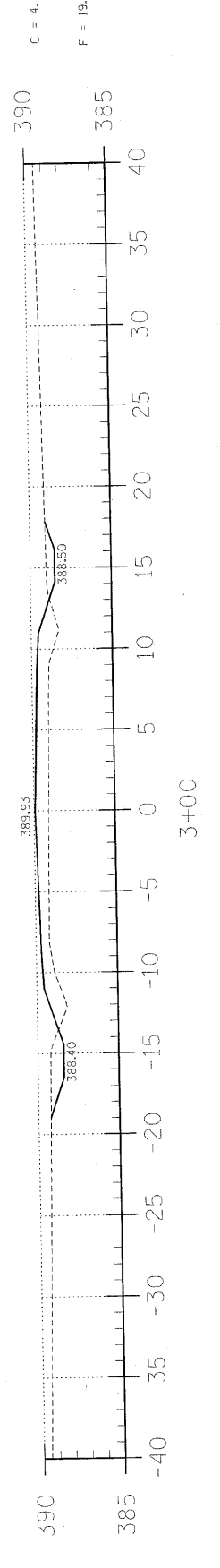
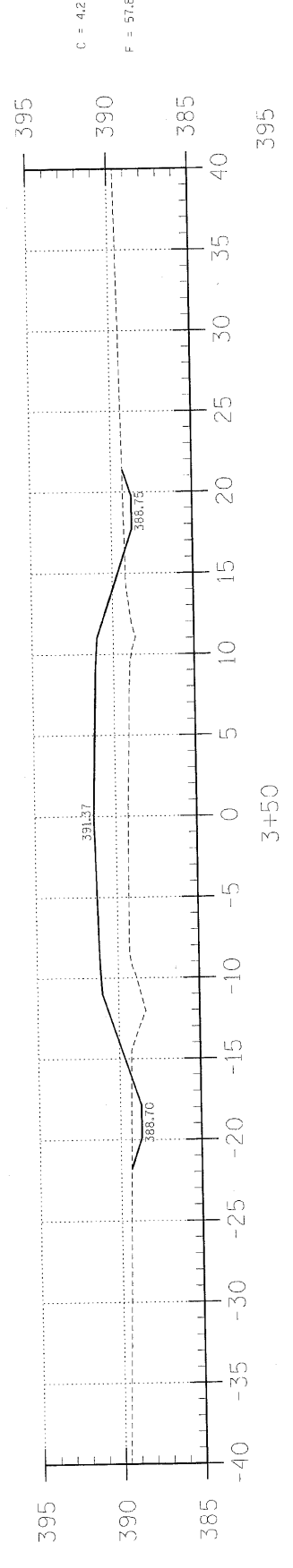
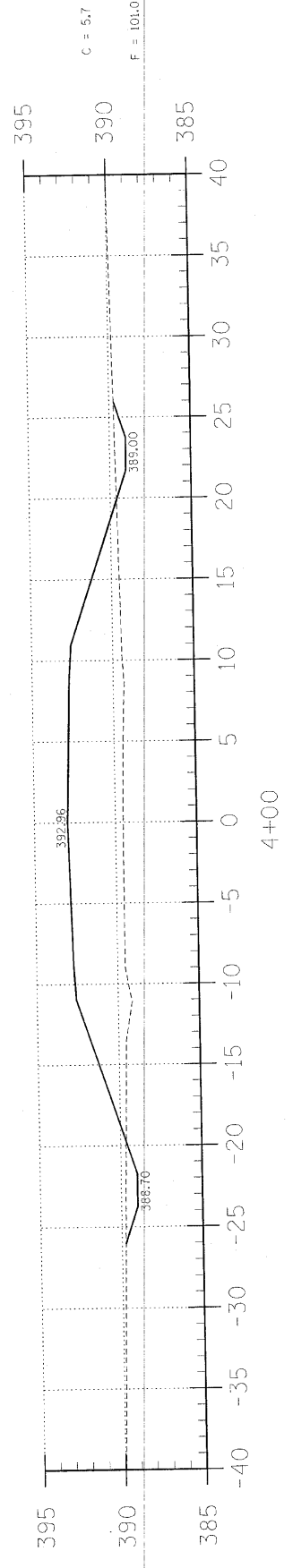
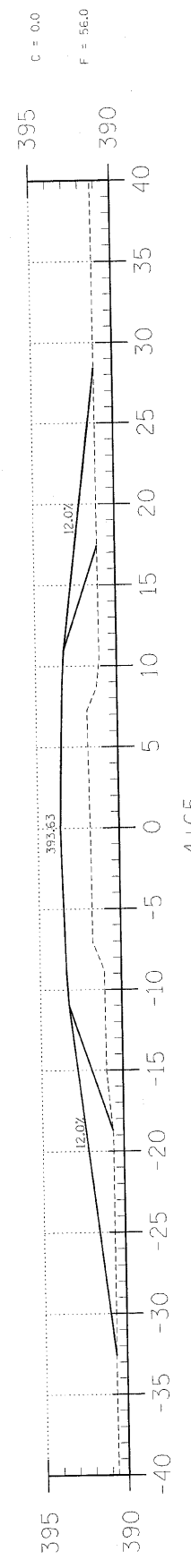

EARTHWORK SCHEDULE

LOCATION	EARTH EXCAVATION		CHANNEL EXCAVATION		ESTIMATED UNSUITABLE MATERIAL		SUITABLE MATERIAL ADJUSTED FOR SHRINKAGE		EMBANKMENT		EARTHWORK BALANCE WASTE (+) OR SHORTAGE (-)	
	CUBIC YARD	CUBIC YARD	CUBIC YARD	CUBIC YARD	CUBIC YARD	CUBIC YARD	CUBIC YARD	CUBIC YARD	CUBIC YARD	CUBIC YARD	CUBIC YARD	CUBIC YARD
STA 0+00 TO 4+71.8	34.2	0.0	0.0	0.0	0.0	25.7	451.0	451.0	0.0	-425.3		
STA 4+71.8 TO 5+28.2	0.0	171.0	85.5	64.1	64.1	268.1	581.9	0.0	0.0	64.1		
STA 5+28.2 TO 10+00	357.4	0.0	0.0	0.0	0.0	0.0	76.7	76.7	581.9	-313.8		
2 FIELD ENTRANCE	0.0	0.0	0.0	0.0	0.0	0.0	0.0	0.0	76.7	-76.7		
TOTAL	391.6	171.0	85.5	357.9	1109.6	-751.7						

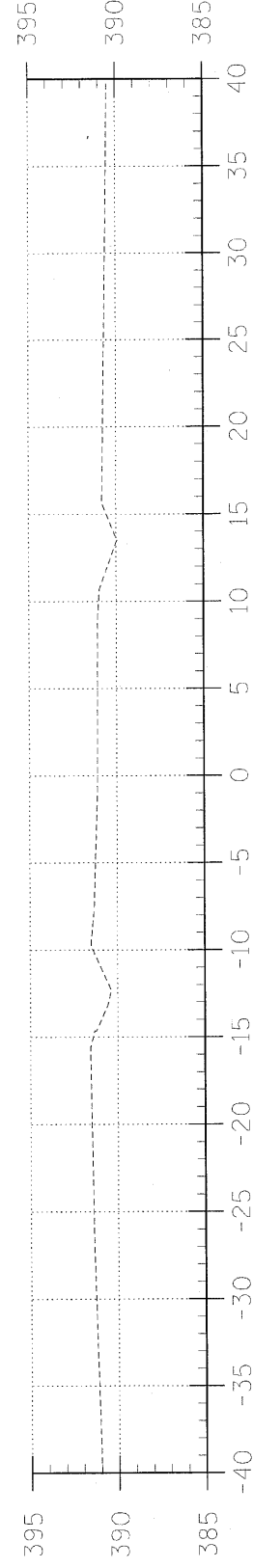

9+00

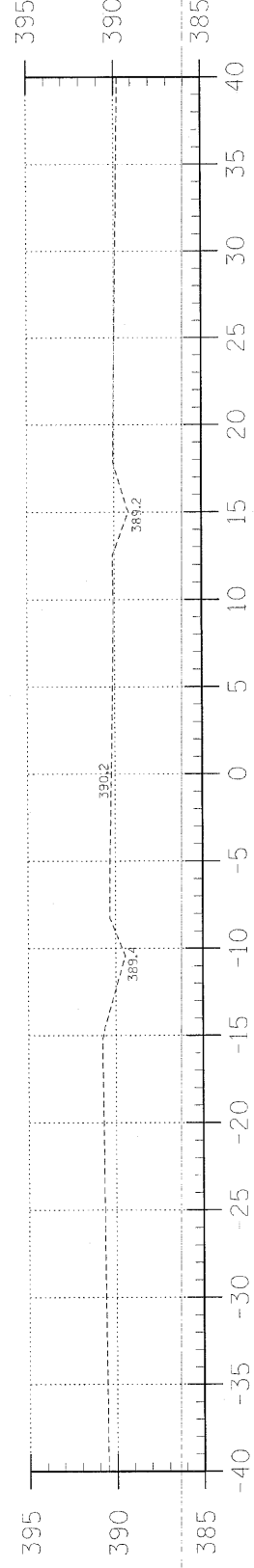

8+00

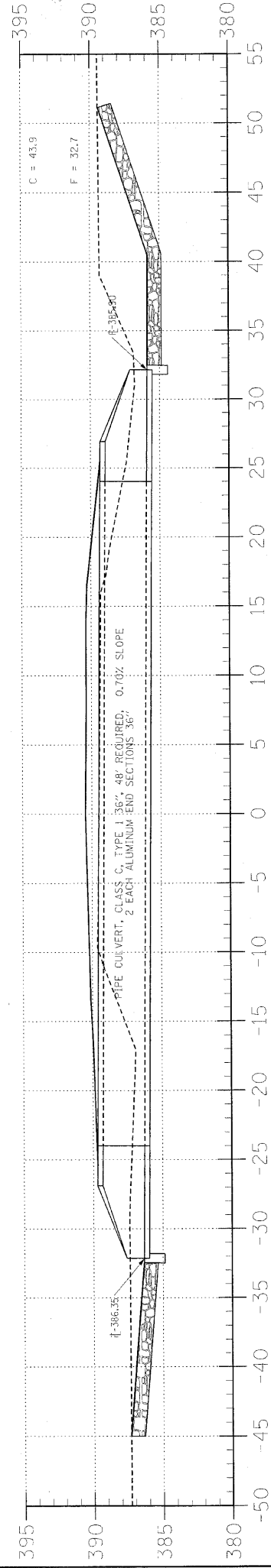

7+05.6 ACROSS ROAD PIPE CULVERT

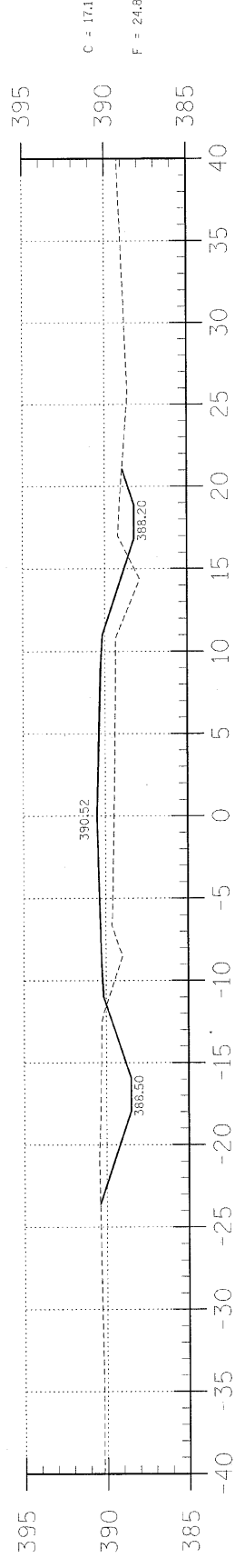

7+00

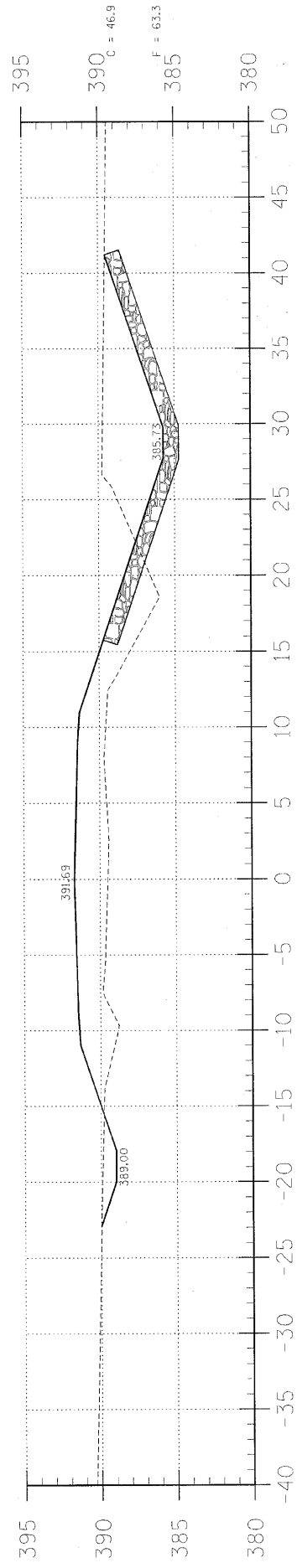

6+150

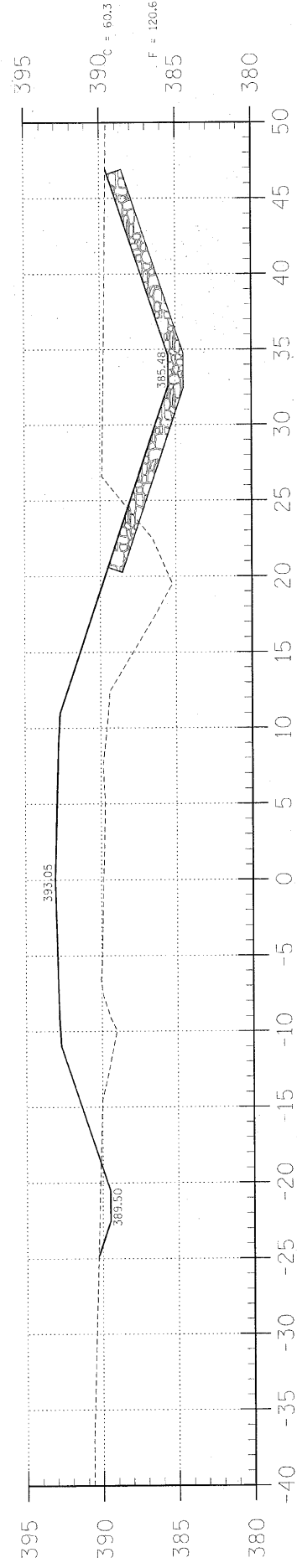

6+00

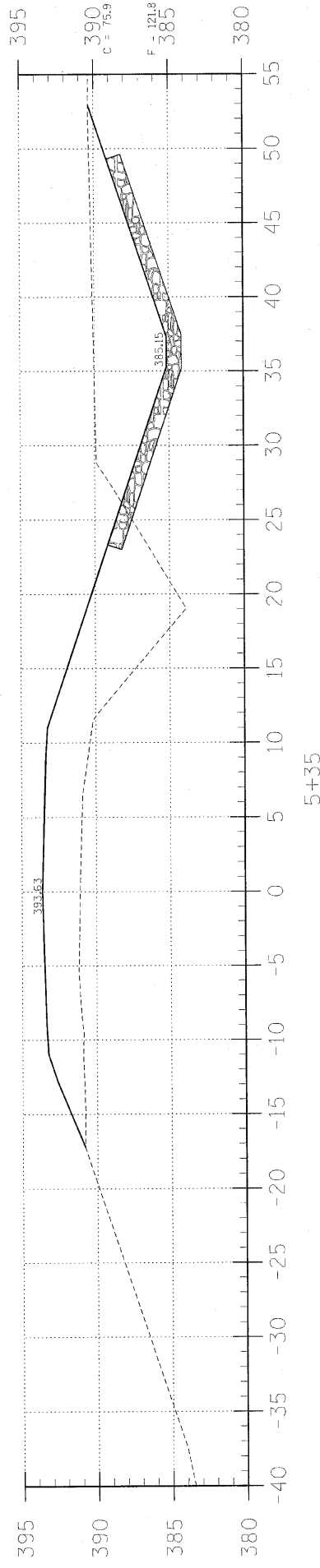

5+35

T.R.	SECTION	COUNTY	TOTAL SHEETS	SHEET NO.
185	07-06115-00-BR	EDWARDS	12	4
FED. ROAD DIST. NO. 7		ILLINOIS	BUTTER CREEK	
PROJECT NO. BR05-04710331		CONTRACT # 95633		
LEC JOB # MOBIL0295D				

323 W. 3RD ST.
P.O. BOX 160
MT. CARMEL, IL
62863
PHONE:
(618)-262-8651
FAX:
(618)-263-3327

405 W. STATE ST.
SUITE 1
PRINCETON, IN
47670
PHONE:
(812)-386-7611
FAX:
(812)-385-2812



PROFESSIONAL DESIGN FIRM
LAND SURVEY &
ENGINEERING
CORPORATION
184-000887
(62-032435)/(35-002769)

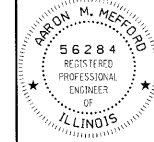

AARON M. MEFFORD
NAME
SIGNATURE
DATE
11-30-11
EXPIRES

BUTTER CREEK
TOWNSHIP ROUTE 185
EDWARDS COUNTY, ILLINOIS

SHEET TITLE:

CROSS-SECTIONS

SCALE: 1" = 5'
BY: AMM
DATE: 6/25/10
REV:

4 OF 12
SHEETS

SHEET NO.
4

BENCHMARK:

EXISTING STRUCTURE: STA. 4+94.3; Structure Number 024-3064; A single span bridge with wood deck and runners on steel beams which sit on steel I-beam caps on wood piles with concrete wingwalls and mud walls. 30.0' bk.-bk. abutts., 15.5' o.-o. deck.

No Salvage.

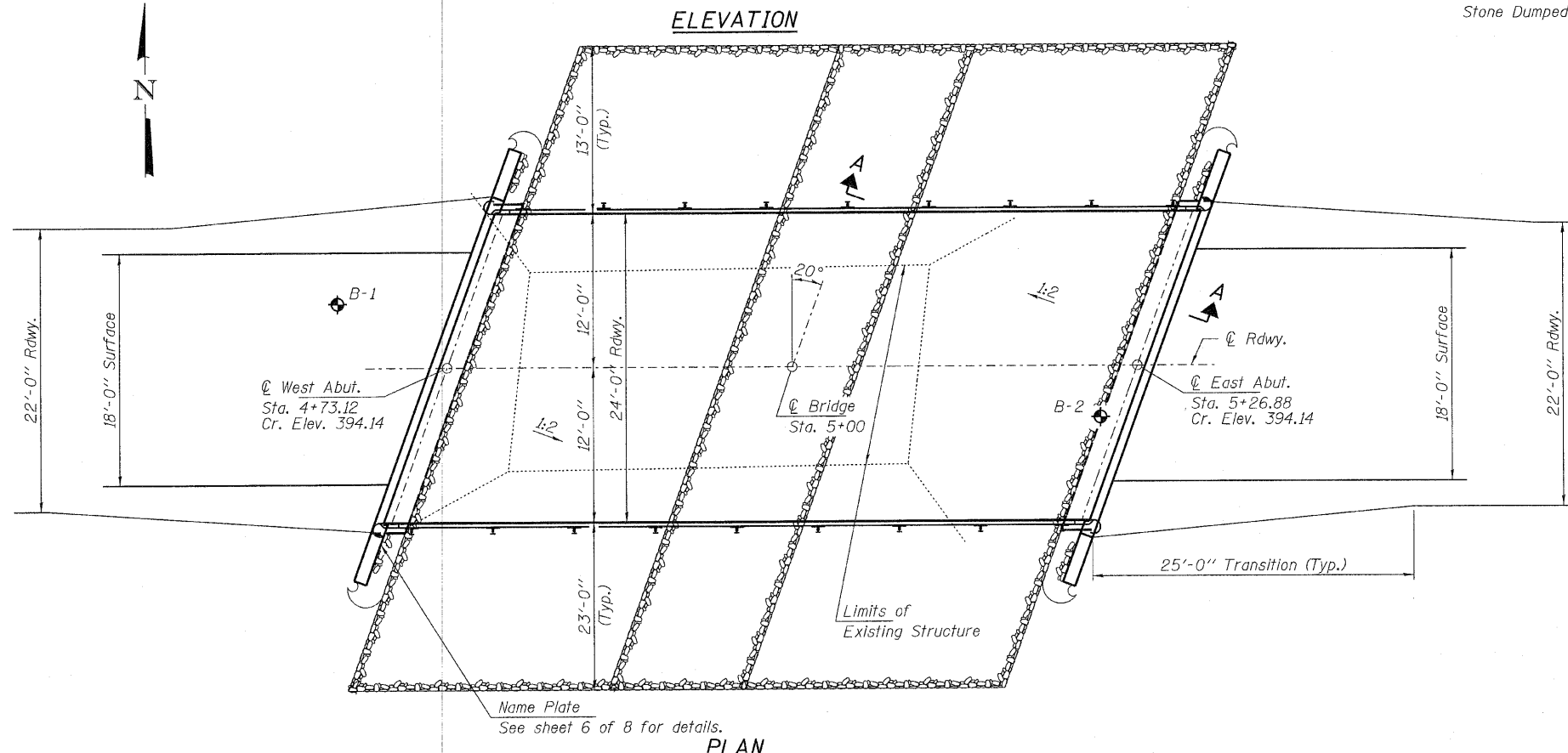
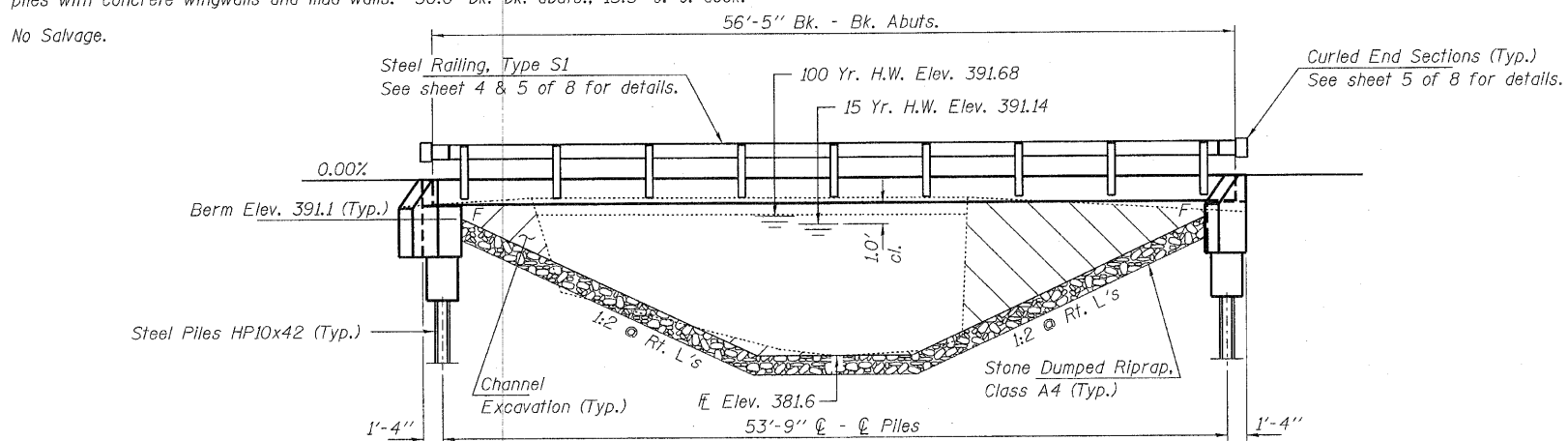

GENERAL NOTES

Layout of the slope protection system may be varied to suit ground conditions in the field as directed by the Engineer.
Reinforcement bars shall conform to the requirements of ASTM A 706 Gr 60 (IL Modified). See Special Provisions.
Excavation required to construct the Abutments shall be included in the cost of Concrete Structures. No additional compensation will be allowed for Structure Excavation.
All proposed construction activities shall be in accordance with Nationwide Permit number 14 of the Department of the Army authorized under Section 404 of the Clean Water Act.
The IEPA has issued Section 401 Water Quality Certification for this activity. See Special Provisions for conditions.

BUTTER CREEK
BUILT 201 BY
EDWARDS COUNTY
SEC. 07-06115-00-BR
ROAD DISTRICT #6
STR. NO. 024-3138
LOADING HL-93

NAME PLATE
See Std. 515001

INDEX OF STRUCTURE SHEETS

1. General Plan & Elevation
2. Superstructure
- 3-4. Superstructure Details
5. Steel Railing, Type S-1
6. Abutments
7. HP Pile Details
8. Borings

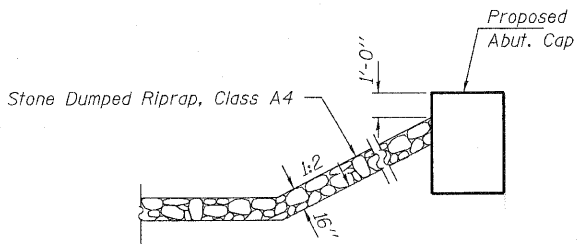

SECTION A-A

Note: See Special Provisions for Stone Dumped Riprap, Class A4.

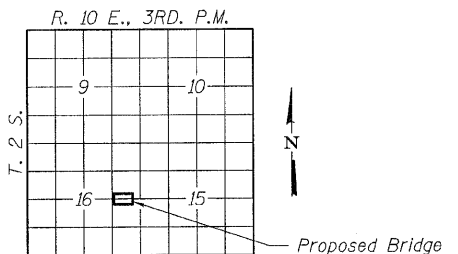

LOCATION SKETCH

TOTAL BILL OF MATERIAL

ITEM	UNIT	SUPER	SUB	TOTAL
Channel Excavation	Cu. Yd.			171
Stone Dumped Riprap, Class A4	Ton			300
Removal of Existing Structures	Each			1
Concrete Structures	Cu. Yd.		23.8	23.8
Concrete Encasement	Cu. Yd.		2.8	2.8
Precast Prestressed Concrete Deck Beams (21" Depth)	Sq. Ft.	1,320		1,320
Reinforcement Bars	Pound		2,560	2,560
Steel Railing, Type S1	Foot	108		108
Furnishing Steel Piles HP10x42	Foot		240	240
Driving Piles	Foot		240	240
Name Plates	Each		1	1

DESIGN STRESSES

FIELD UNITS

f'c = 3,500 psi
fy = 60,000 psi (Reinf.)

PRECAST PRESTRESSED UNITS

f'c = 6,000 psi
f'ci = 5,000 psi
fpu = 270,000 psi (1/2" low lax. strands)
fpbt = 201,960 psi (1/2" low lax. strands)
fy = 60,000 psi (Reinf.)

LOADING HL-93

Design Specifications: 2010 AASHTO LRFD with all applicable Interims.
50#/Sq. Ft. included in dead load for future wearing surface.

SEISMIC DATA

Seismic Performance Zone (SPZ) = 2
Design Spectral Acceleration at 1.0 sec. (Sp1) = 0.274g
Design Spectral Acceleration at 0.2 sec. (Sps) = 0.654g
Soil Site Class = D

WATERWAY INFORMATION

Flood	Freq. Yr.	Q C.F.S.	Opening Sq. Ft.		Natural H.W.E.	Head - Ft.		Headwater El.	
			Exist.	Prop.		Exist.	Prop.	Exist.	Prop.
Design	15	1490	202	285.9	391.14	0.29	0.05	391.43	391.19
Base	100	2590	230	312.0	391.68	0.01	0.02	391.69	391.70
Max. Calc.	500	-	-	-	-	-	-	-	-

Existing Low Grade Elev. 388.5 @ Sta. 0+00
Proposed Low Grade Elev. 388.5 @ Sta. 0+00

I certify that to the best of my knowledge, information and belief, this bridge design is structurally adequate for the design loading shown on the plans. The design is an economical one for the style of structure and complies with requirements of the current "AASHTO LRFD Specifications."



Steven W. McGinnis 6/23/2010
ILLINOIS STRUCTURAL NO. 081-6064 Expires 11-30-2010

**GENERAL PLAN AND ELEVATION
STRUCTURE NO. 024-3138**

DESIGNED - A.S.L.
CHECKED - S.W.M.
DRAWN - D.A.B.
CHECKED - S.W.M.

HAMPTON, LENZINI AND RENWICK, INC.
CIVIL ENGINEERS - STRUCTURAL ENGINEERS - LAND SURVEYORS
3085 STEVENSON DRIVE, SUITE 201
SPRINGFIELD, ILLINOIS 62703
217.546.3400 www.hlrengineering.com
194.00959
ILLINOIS PROFESSIONAL DESIGN FIRM L.S./P.E./S.E. CORPORATION
PROJECT NUMBER: 09.0007.130 DATE: 02/23/10

SHEET NO. 1 8 SHEETS	T.R.	SECTION	COUNTY	TOTAL SHEETS	SHEET NO.
	185	07-06115-00-BR	EDWARDS	12	5
ROAD DISTRICT #6			CONTRACT NO. 95633		
FED. ROAD DIST. NO.		ILLINOIS	FED. AID PROJECT		

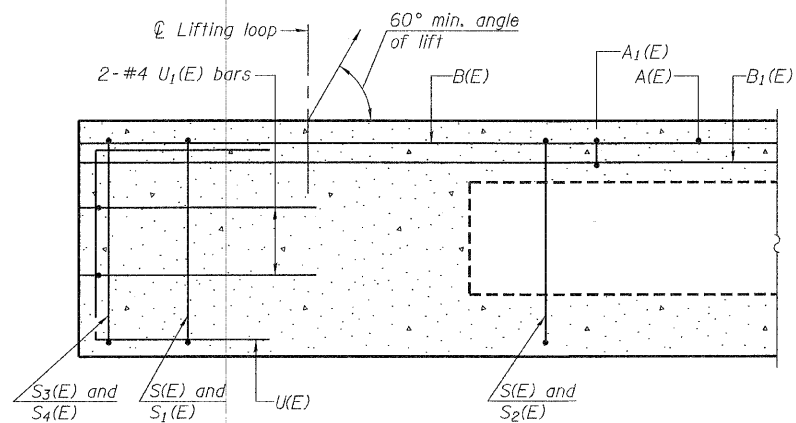

SECTION C-C

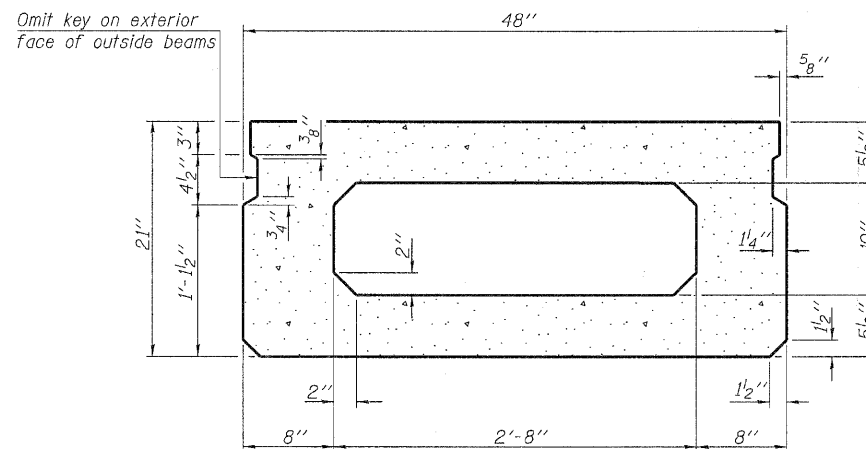

SECTION A-A
(Showing dimensions)

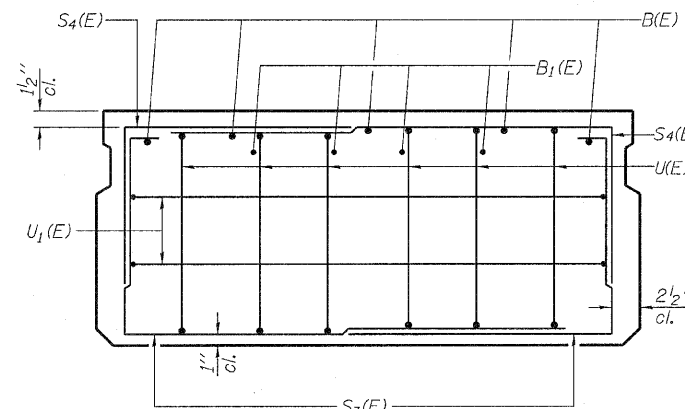

VIEW B-B

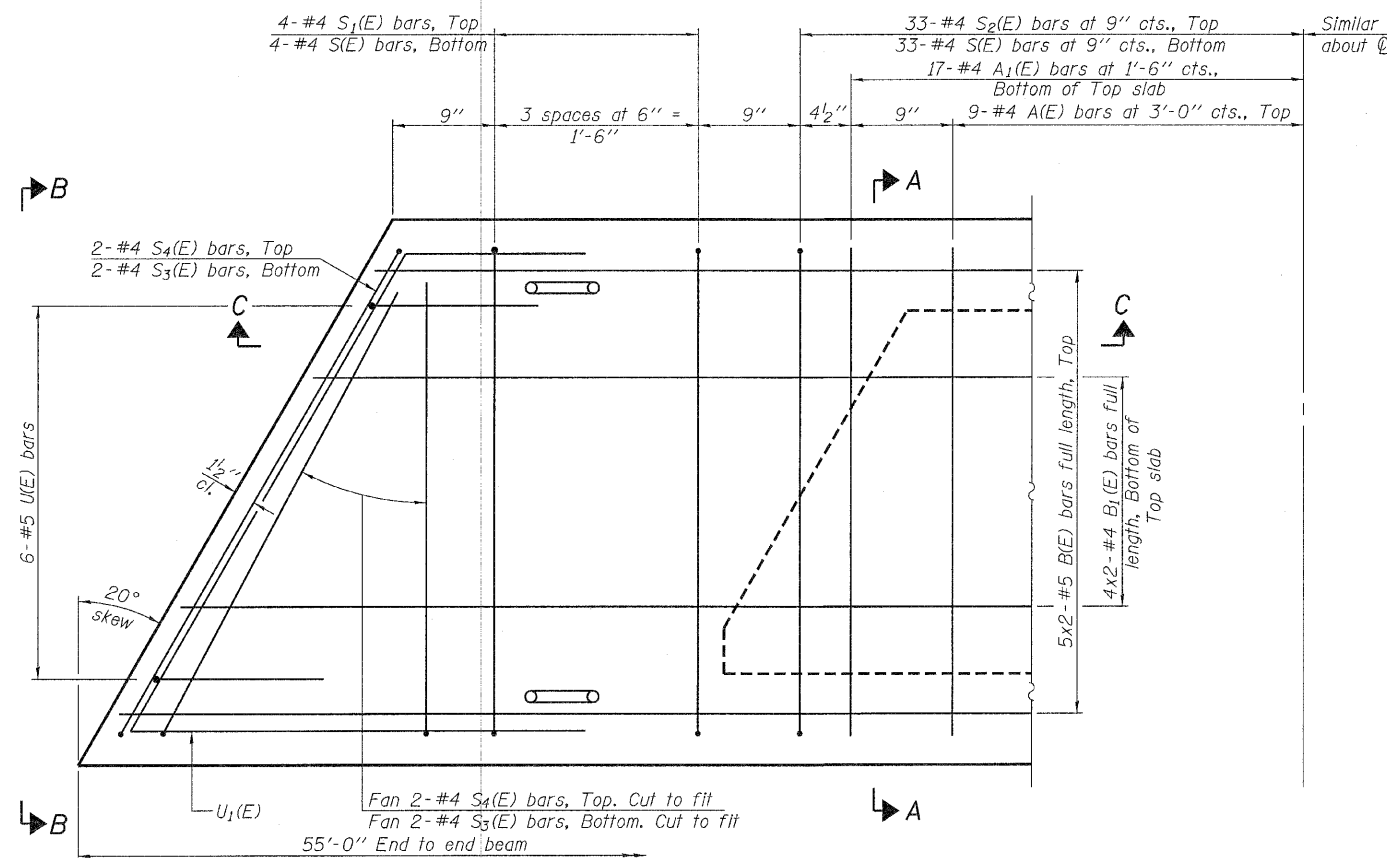

PLAN VIEW

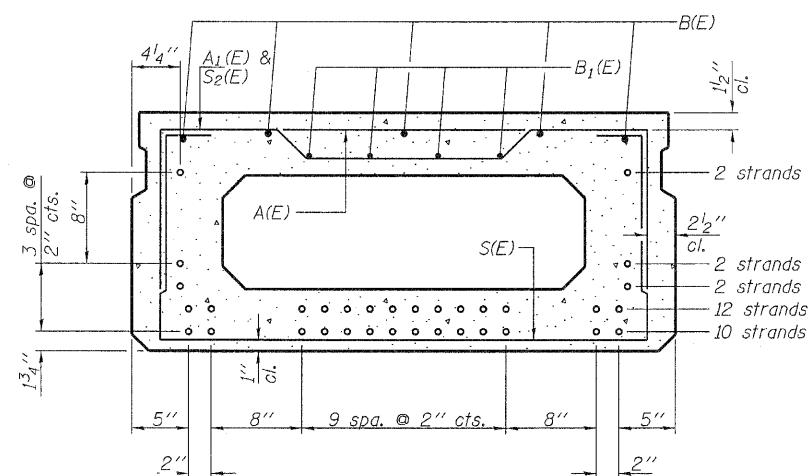

SECTION A-A
(Showing reinforcement and permissible strand locations)

Note: Place the number of strands specified in each row symmetrically about the centerline of beam in the permissible strand locations shown.

BAR LIST
ONE BEAM ONLY
(For information only)

Bar	No.	Size	Length	Shape
A(E)	18	#4	3'-7"	—
A1(E)	34	#4	3'-10"	—
B(E)	10	#5	28'-8"	—
B1(E)	8	#4	28'-5"	—
S(E)	74	#4	7'-5"	U
S1(E)	8	#4	5'-11"	U
S2(E)	66	#4	6'-2"	U
S3(E)	8	#4	4'-9"	U
S4(E)	8	#4	4'-0"	U
U(E)	12	#5	4'-0"	U
U1(E)	4	#4	7'-6"	U

Note: See sheets 3 & 4 of 8 for additional details and Bill of Material.

MINIMUM BAR LAP

#4 bar = 2'-0"
#5 bar = 2'-6"

Notes:
Spacing of S(E) and S2(E) bars may be adjusted up to 4" in the immediate area of the transverse tie diaphragms to miss the block outs for the transverse ties.
Bars indicated thus 5x2-#4 etc. indicates 5 lines of bars with 2 lengths per line.

DESIGNED - A.S.L.
CHECKED - S.W.M.
DRAWN - D.A.B.
CHECKED - S.W.M.

PD-2148-L

11-1-09

HAMPTON, LENZINI AND RENWICK, INC.
CIVIL ENGINEERS • STRUCTURAL ENGINEERS • LAND SURVEYORS
3085 STEVENSON DRIVE, SUITE 201
SPRINGFIELD, ILLINOIS 62703
217.546.3400 www.hireengineering.com

164.00099
ILLINOIS PROFESSIONAL DESIGN FIRM LS / PE / SE CORPORATION

PROJECT NUMBER: 09.0007.130 DATE: 02/23/10

SHEET NO. 2 8 SHEETS	T.R.	SECTION	COUNTY	TOTAL SHEETS	SHEET NO.
	185	07-06115-00-BR	EDWARDS	12	6
ROAD DISTRICT #6			CONTRACT NO. 95633		
FED. ROAD DIST. NO.		ILLINOIS FED. AID PROJECT			

SUPERSTRUCTURE
21" X 48" PPC DECK BEAM
STRUCTURE NO. 024-3138

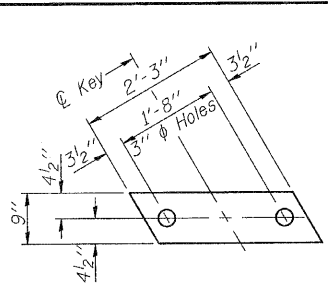

FABRIC BEARING PAD
(Interior - 10 Req'd.)

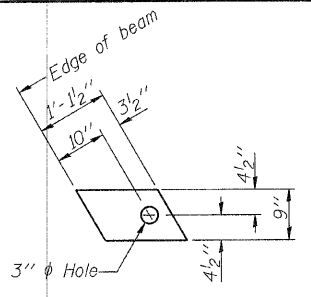

FABRIC BEARING PAD
(Exterior - 4 Req'd.)

FIXED
Notes:
All bearing pads shall be 1" thick.
Omit holes when using expansion bearings.
Expansion bearing pad shall be bonded to the substructure.

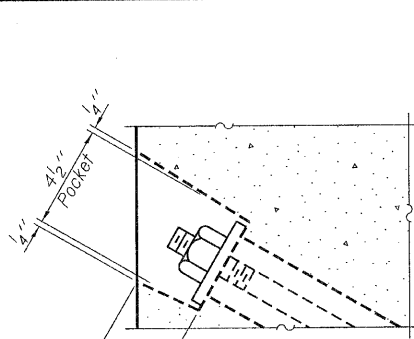

SECTION A-A

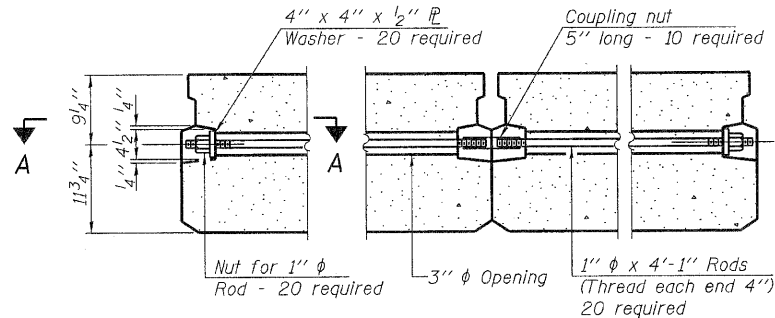

TYPICAL TRANSVERSE TIE ASSEMBLY

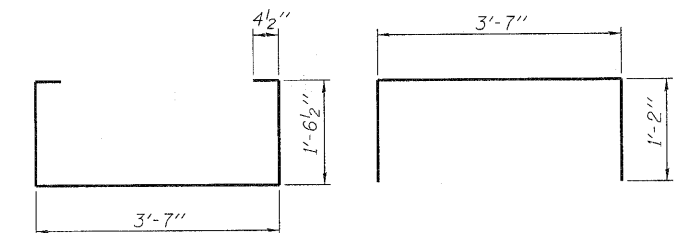

BAR S₁(E)

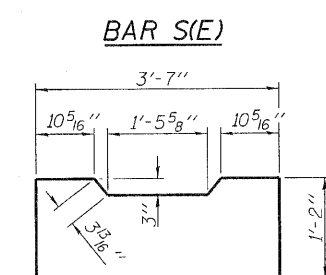

BAR S(E)

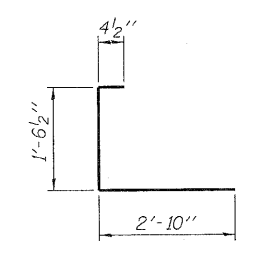

BAR S₂(E)

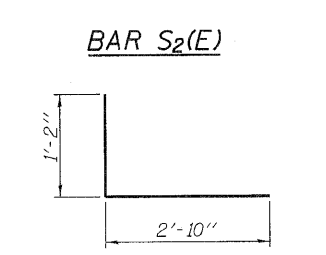

BAR S₃(E)

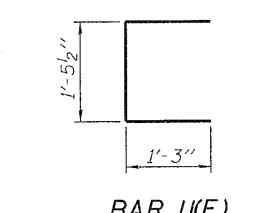

BAR S₄(E)

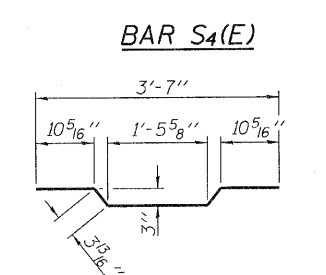

BAR U₁(E)

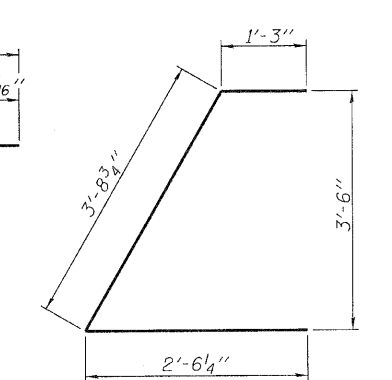

BAR A₁(E)

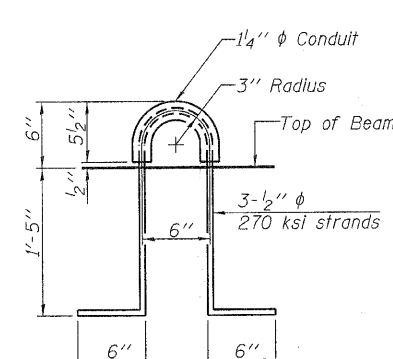

LIFTING LOOP DETAIL

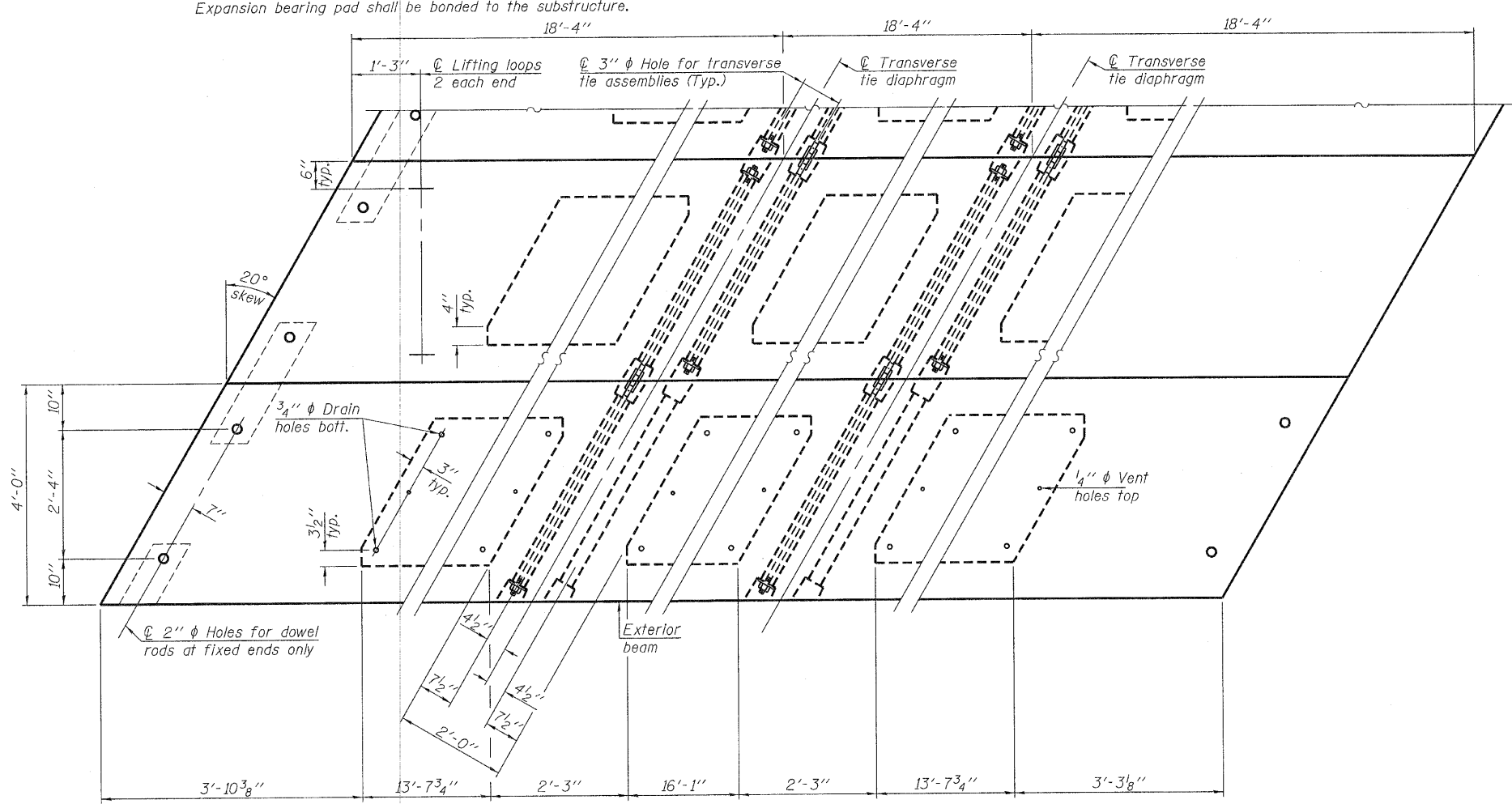

PLAN VIEW

NOTES

Prestressing steel shall be uncoated high strength, low relaxation 7-wire strand, Grade 270. The nominal diameter shall be 1/2" and the nominal cross-sectional area shall be 0.153 sq. in. The 1" rods in the transverse tie assembly shall be tightened to a snug fit and the threads set. Pockets on exterior faces of bridge shall be filled with grout after transverse tie assembly is in place. Reinforcement bars shall conform to ASTM A 706, Grade 60. (See Special Provisions). Two 1/8" fabric adjusting shims of the dimensions of the exterior bearing pad shall be provided for each bearing pad location. A minimum 2 1/2" diameter lifting pin shall be used to engage the lifting loops during handling. Corrosion Inhibitor, per Article 1020.05(b)(12) and 1021.06 of the Standard Specifications, shall be used in the concrete for precast prestressed concrete deck beams. Compressive strength of prestressed concrete, f'c, shall be 6000 psi. Compressive strength of prestressed concrete at release, f'ci, shall be 5000 psi. All reinforcement shall be epoxy coated.

Note: Connect beams in pairs with the transverse tie configuration shown.

DESIGNED - A.S.L.
CHECKED - S.W.M.
DRAWN - D.A.B.
CHECKED - S.W.M.

PD-2148-LD

11-1-09

BILL OF MATERIAL

Precast Prestressed Conc. Deck Bms. (21" depth)	Sq. Ft.	1,320
---	---------	-------

SUPERSTRUCTURE DETAILS
21" X 48" PPC DECK BEAM DETAILS
STRUCTURE NO. 024-3138

HAMPTON, LENZINI AND RENWICK, INC. CIVIL ENGINEERS • STRUCTURAL ENGINEERS • LAND SURVEYORS 3085 STEVENSON DRIVE, SUITE 201 SPRINGFIELD, ILLINOIS 62703 217.546.3400 www.hlrenw.com 184.00989 ILLINOIS PROFESSIONAL DESIGN FIRM LS / PE / SE CORPORATION PROJECT NUMBER: 09.0007.130 DATE: 02/23/10	SHEET NO. 3	T.R.	SECTION	COUNTY	TOTAL SHEETS	SHEET NO.
	8 SHEETS	185	07-06115-00-BR	EDWARDS	12	7
			ROAD DISTRICT #6	CONTRACT NO. 95633		
			FED. ROAD DIST. NO.	ILLINOIS FED. AID PROJECT		

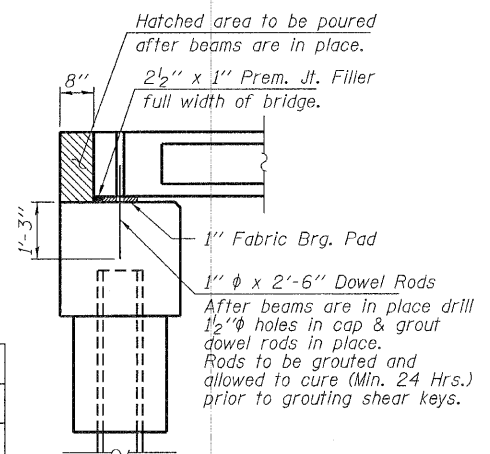
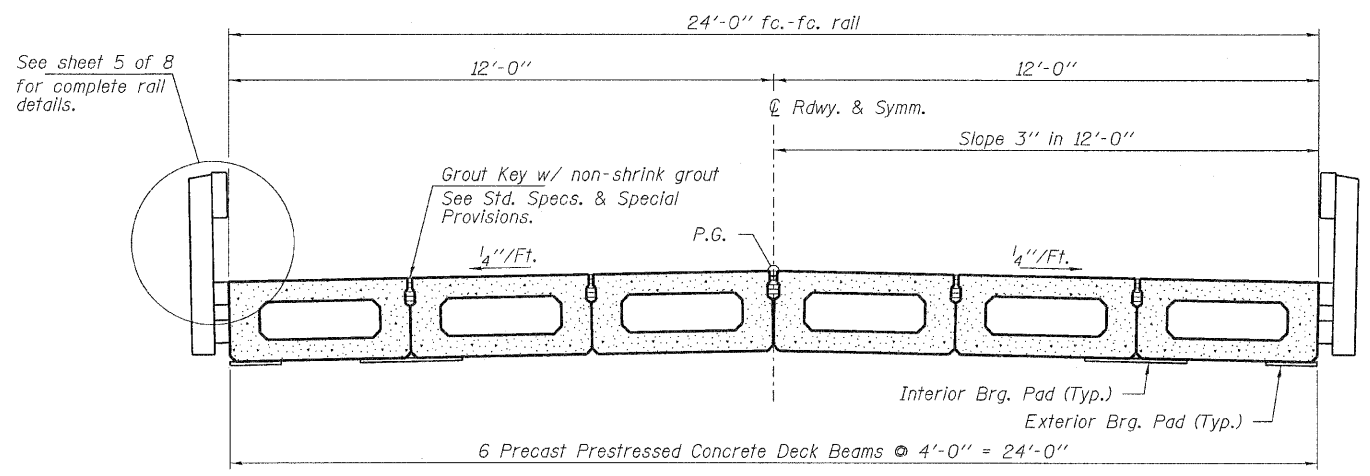
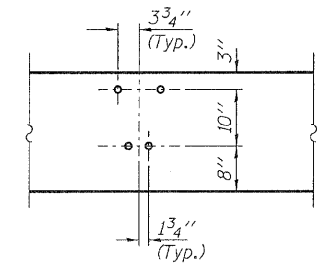
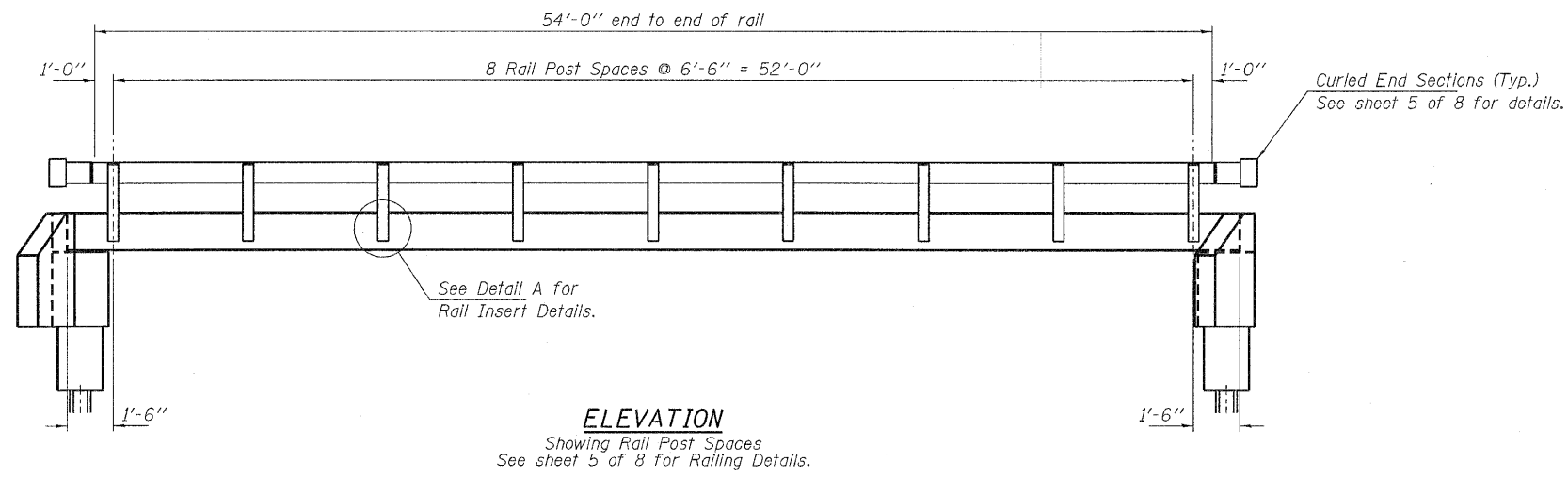

DESIGNED - A.S.L.
CHECKED - S.W.M.
DRAWN - D.A.B.
CHECKED - S.W.M.

SUPERSTRUCTURE DETAILS
STRUCTURE NO. 024-3138

HAMPTON, LENZINI AND RENWICK, INC. CIVIL ENGINEERS • STRUCTURAL ENGINEERS • LAND SURVEYORS HLR 3085 STEVENSON DRIVE, SUITE 201 SPRINGFIELD, ILLINOIS 62703 217.548.3400 www.hirengineering.com 184.000999 ILLINOIS PROFESSIONAL DESIGN FIRM LS / PE / SE CORPORATION	SHEET NO. 4	T.R.	SECTION	COUNTY	TOTAL SHEETS	SHEET NO.
	8 SHEETS	185	07-06115-00-BR	EDWARDS	12	8
PROJECT NUMBER: 09.0007.130	DATE: 02/23/10	ROAD DISTRICT #6		CONTRACT NO. 95633		
		FED. ROAD DIST. NO.	ILLINOIS	FED. AID PROJECT		

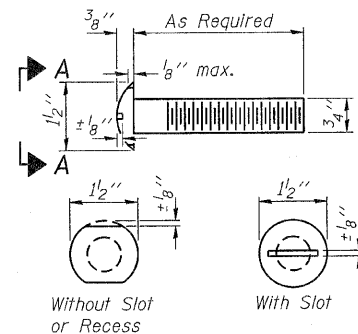

**VIEW A-A
ROUND HEAD BOLT**

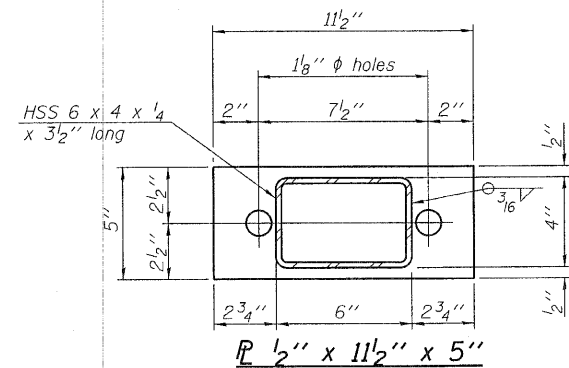

SECTION B-B

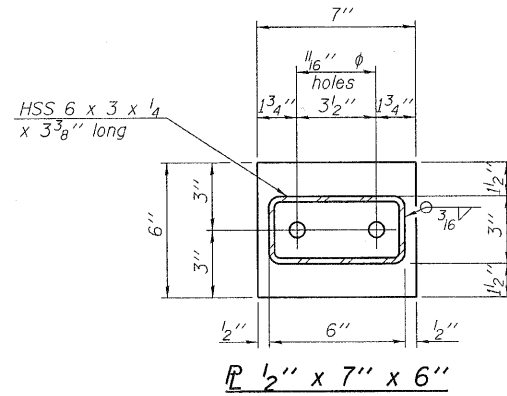

SECTION AT RAILING POST

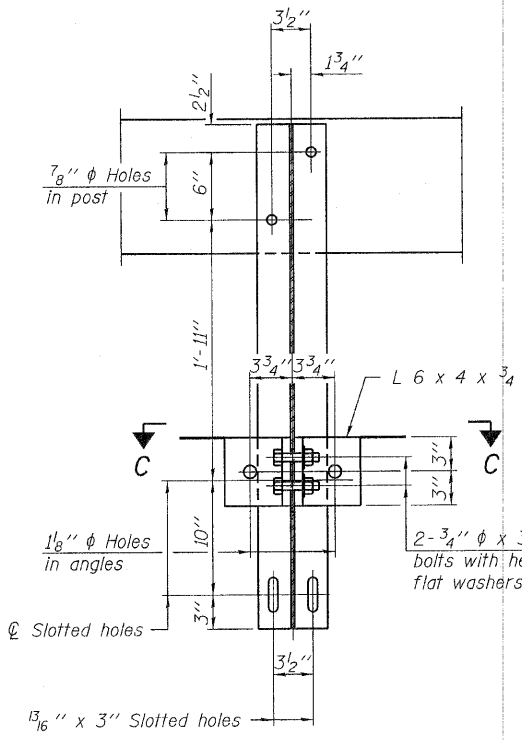

SECTION C-C

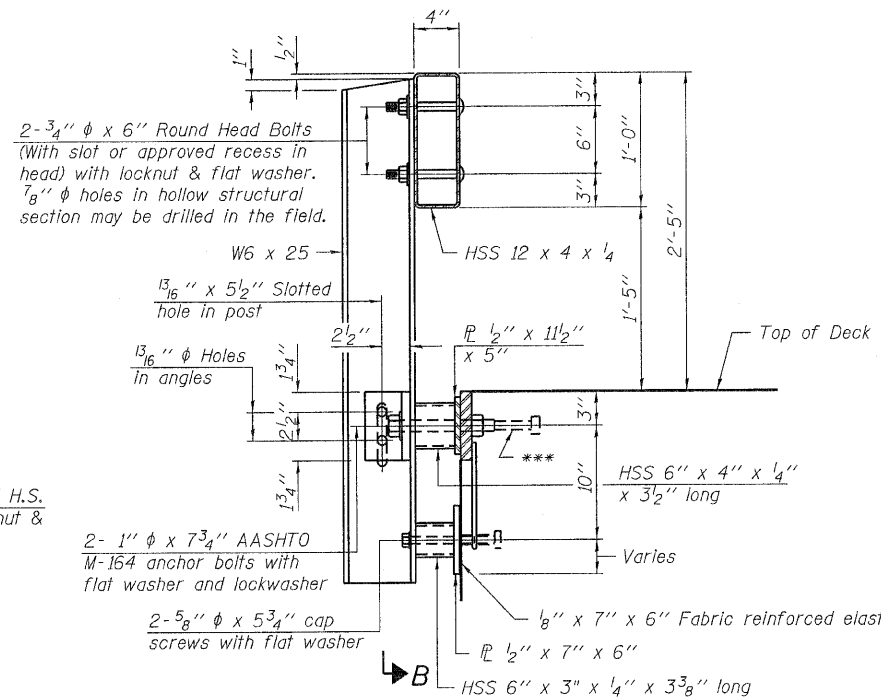

SECTION AT RAILING POST

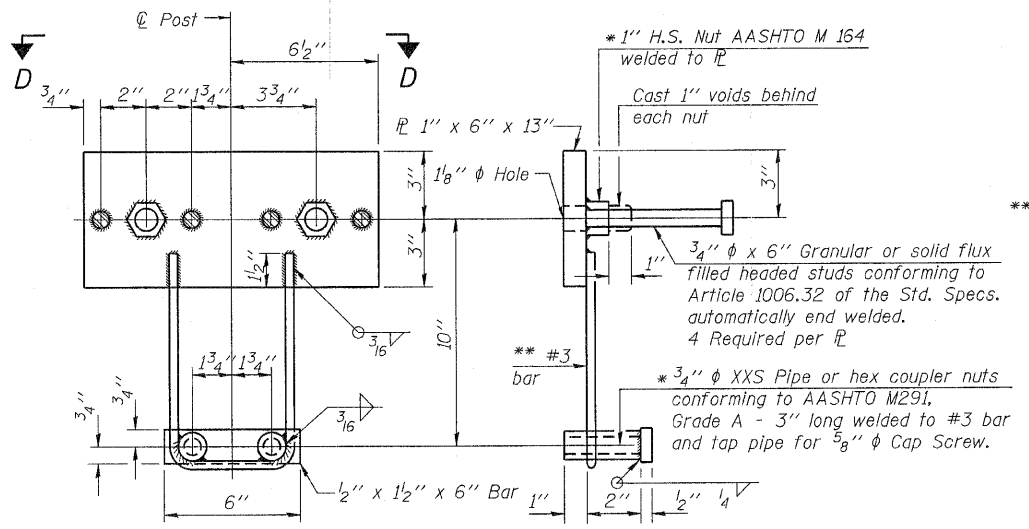

ANCHOR DEVICE

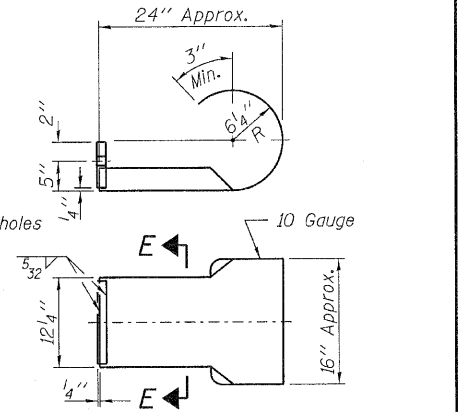

SECTION E-E CURLED END SECTION DETAILS

Note: Cost of curled end sections shall be included with the Steel Railing. (4 Required)

Notes:
All field drilled holes shall be coated with an approved zinc rich paint before erection.
For multi-span bridges, sufficient 1/4 inch x 6 inch x 1-2 inch galvanized steel shims shall be provided to align rail between adjacent spans. Cast included with Steel Railing, Type S-1.
All steel rail elements shall be galvanized according to Article 509.05 of the Standard Specifications.
*** The studs of the anchor devices shall be placed below the top reinforcement bars and the outermost longitudinal reinforcement bar shall be placed directly above the studs of the rail post anchor device.

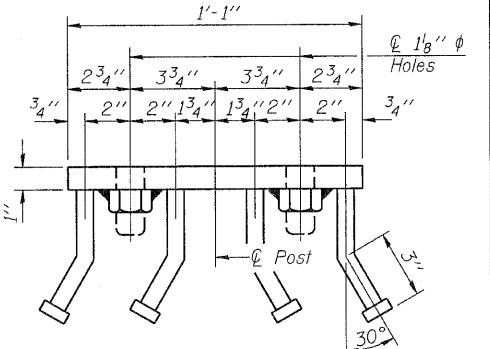

VIEW D-D

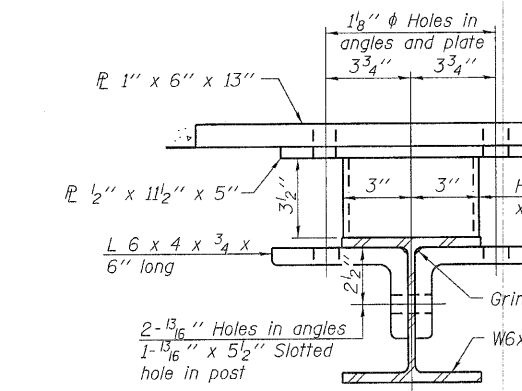

SECTION C-C

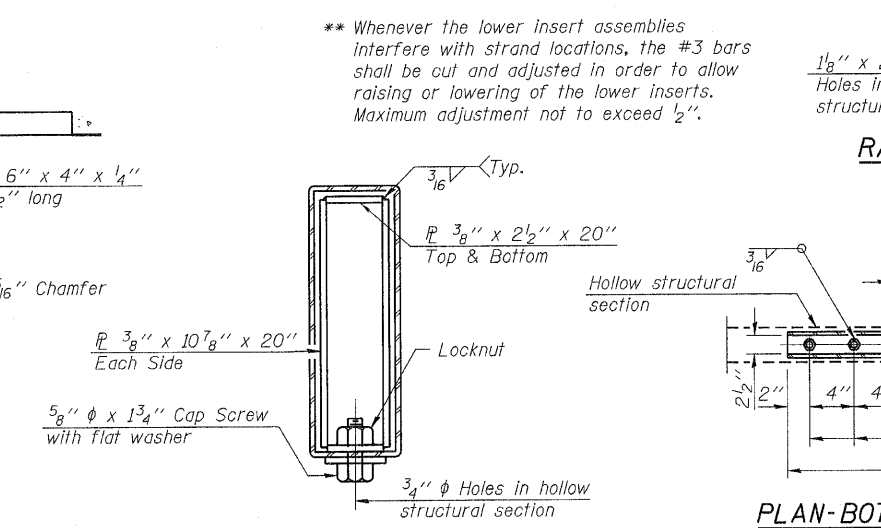

SECTIONS AT RAIL SPLICE

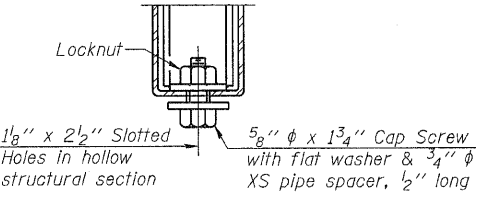

RAIL SPLICE CONNECTION AT EXPANSION JT.

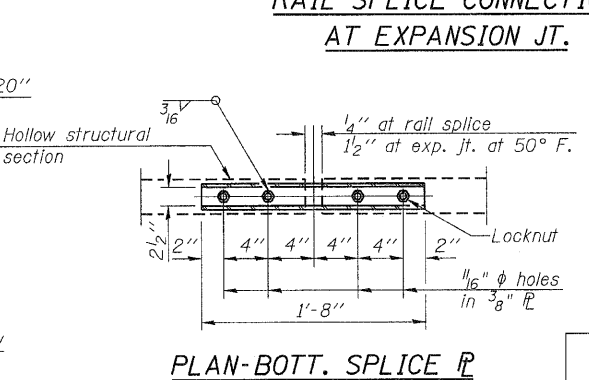

PLAN-BOTT. SPLICE TYPICAL

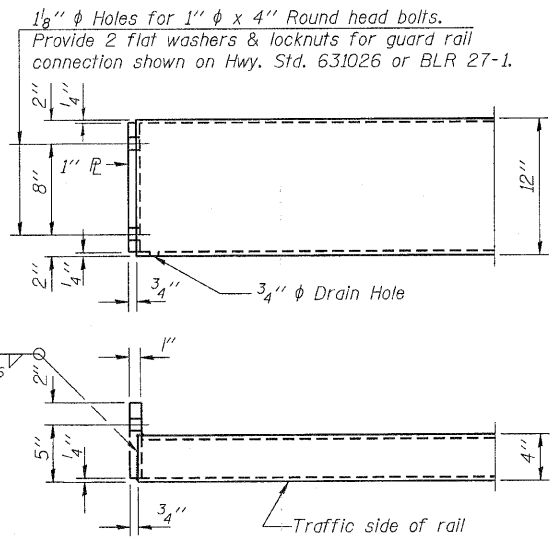

END OF RAIL DETAILS

BILL OF MATERIAL

Item	Unit	Quantity
Steel Railing, Type S-1	Foot	108

**STEEL RAILING, TYPE S-1
STRUCTURE NO. 024-3138**

DESIGNED - A.S.L.
CHECKED - S.W.M.
DRAWN - D.A.B.
CHECKED - S.W.M.

R-23A

11-1-09 (10'-9" Maximum Post Spacing)

HAMPTON, LENZINI AND RENWICK, INC.
CIVIL ENGINEERS - STRUCTURAL ENGINEERS - LAND SURVEYORS
3085 STEVENSON DRIVE, SUITE 201
SPRINGFIELD, ILLINOIS 62703
217.546.3400 www.hlrengineering.com

HLR
184 009899
ILLINOIS PROFESSIONAL DESIGN FIRM L3 / PE / SE CORPORATION

PROJECT NUMBER: 09.0007.130 DATE: 02/23/10

SHEET NO. 5	T.R.	SECTION	COUNTY	TOTAL SHEETS	SHEET NO.
8 SHEETS	185	07-06115-00-BR	EDWARDS	12	9
	ROAD DISTRICT #6		CONTRACT NO. 95633		
	FED. ROAD DIST. NO.	ILLINOIS	FED. AID PROJECT		

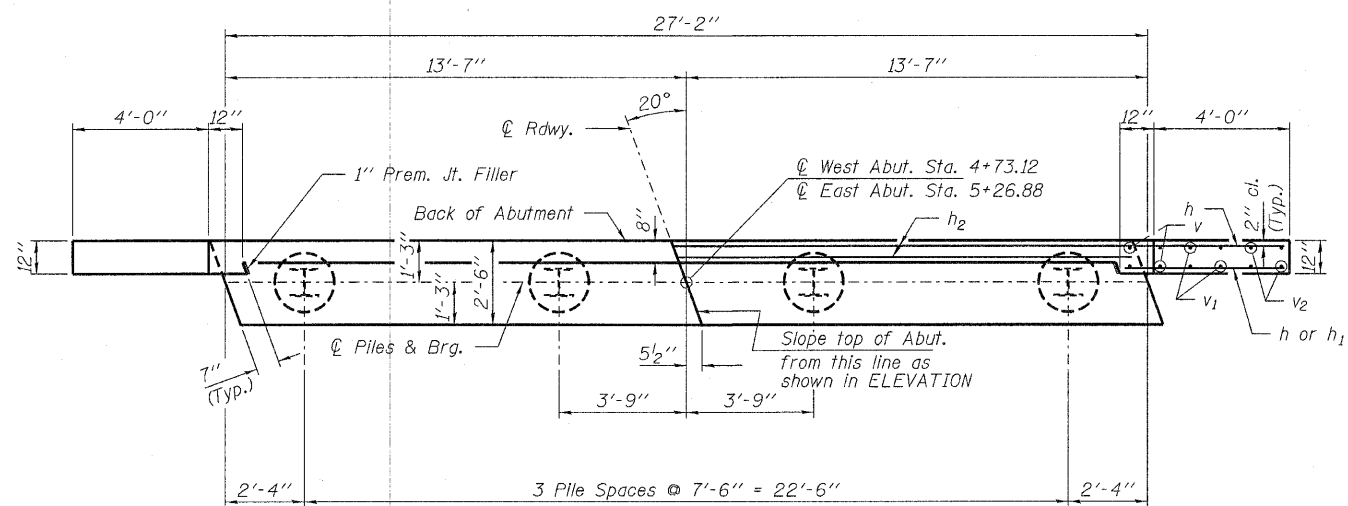

PLAN

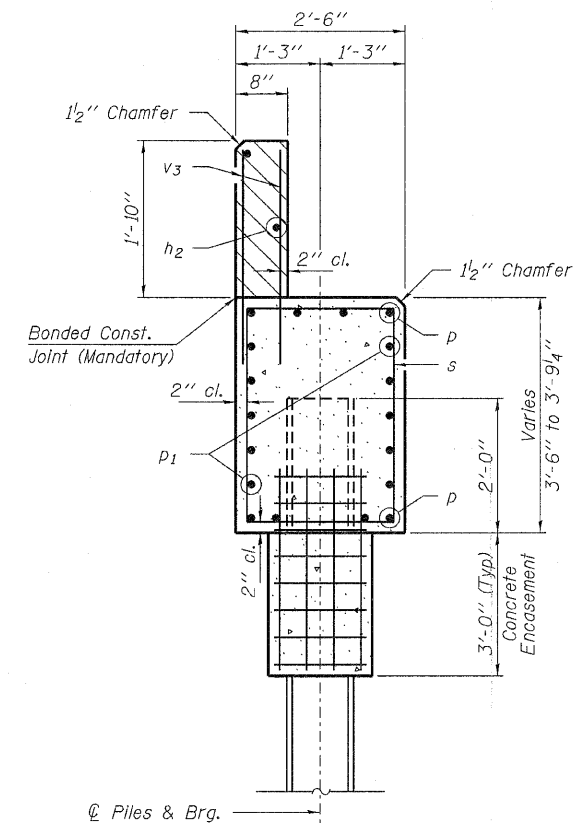

SECTION A-A

Hatched area to be poured after beams are in place.

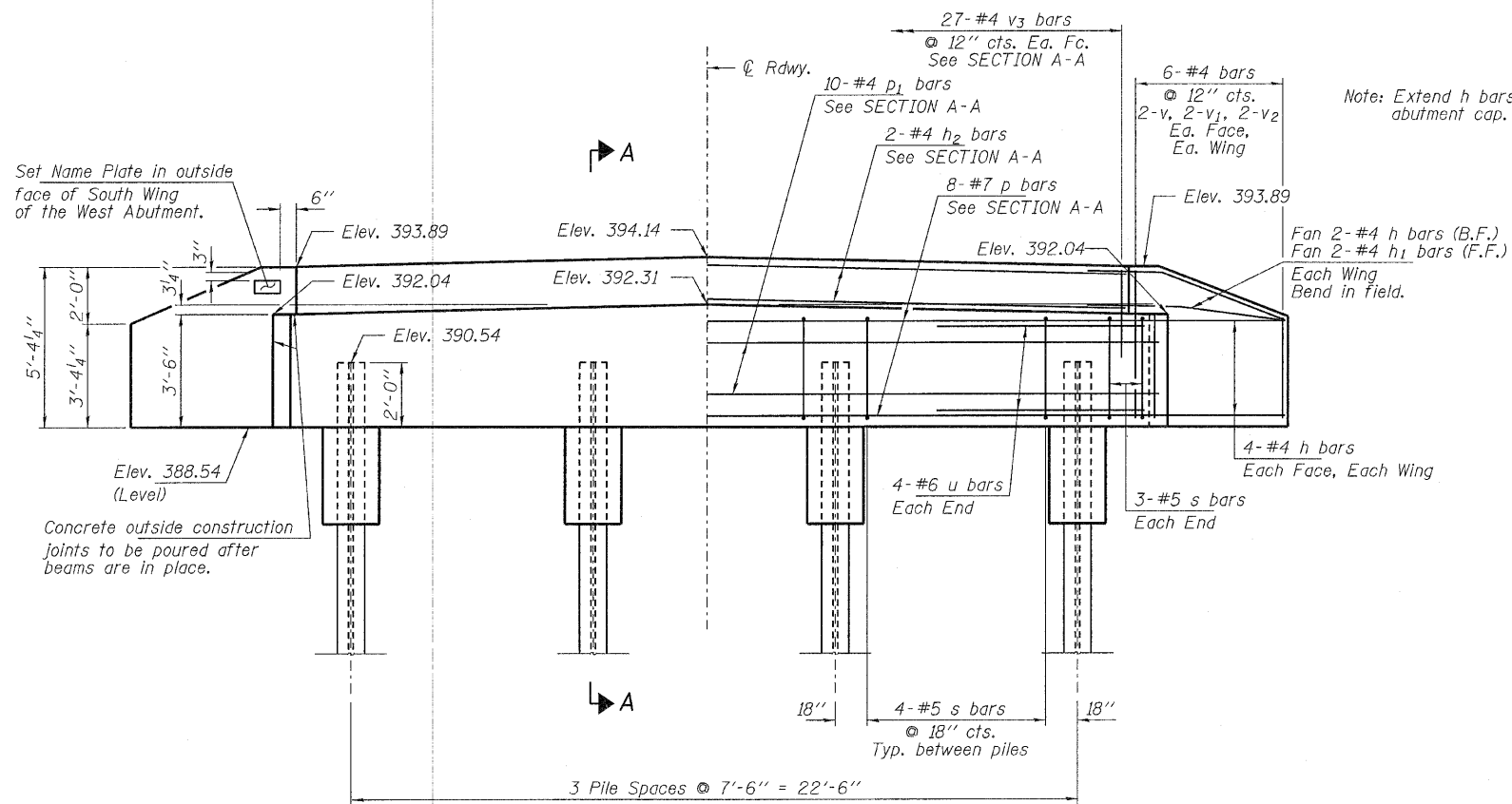

ELEVATION

Note: Extend h bars into abutment cap.

PILE DATA

Type: Steel HP10x42
 No. Req'd. (2 Abutments): 8
 Factored Resistance Available (Rf): 167 Kips/Pile
 Nominal Required Bearing (Rn): 335 Kips/Pile
 Est. Length: 30 Ft/Pile

Notes: The Steel H-Piles shall be according to AASHTO M270 Grade 50.

BILL OF MATERIAL - 2 ABUTS.

BAR	NO.	SIZE	LENGTH	SHAPE
h	40	#4	6'-3"	—
h ₁	8	#4	4'-9"	—
h ₂	4	#4	26'-10"	—
p	16	#7	26'-10"	—
p ₁	20	#4	26'-10"	—
s	36	#5	11'-7"	□
u	16	#6	12'-3"	—
v	16	#4	5'-0"	—
v ₁	16	#4	4'-1"	—
v ₂	16	#4	3'-1"	—
v ₃	112	#4	2'-8"	—
Concrete Structures			Cu. Yd.	23.8
Concrete Encasement			Cu. Yd.	2.8
Reinforcement Bars			Pound	2,560
Steel Piles HP10x42			Foot	240
Name Plates			Each	1

ABUTMENTS
 STRUCTURE NO. 024-3138

DESIGNED - A.S.L.
CHECKED - S.W.M.
DRAWN - D.A.B.
CHECKED - S.W.M.

HAMPTON, LENZINI AND RENWICK, INC.
 CIVIL ENGINEERS - STRUCTURAL ENGINEERS - LAND SURVEYORS
 3085 STEVENSON DRIVE, SUITE 201
 SPRINGFIELD, ILLINOIS 62703
 217.546.3400 www.hlr-engineering.com

154 00099
 ILLINOIS PROFESSIONAL DESIGN FIRM LS / PE / SE CORPORATION

PROJECT NUMBER: 09.0007.130 DATE: 02/23/10

SHEET NO. 6	T.R.	SECTION	COUNTY	TOTAL SHEETS	SHEET NO.
	185	07-06115-00-BR	EDWARDS	12	10
8 SHEETS	ROAD DISTRICT #6		CONTRACT NO. 95633		
	FED. ROAD DIST. NO.	ILLINOIS	FED. AID PROJECT		

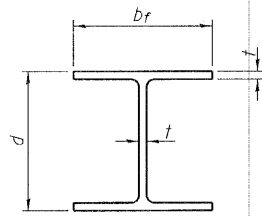

STEEL PILE TABLE

Designation	Depth d	Flange width b _f	Web and Flange thickness t	Encasement diameter A
HP 14x117	14 1/4"	14 7/8"	13/16"	30"
x102	14"	14 3/4"	1/16"	30"
x89	13 7/8"	14 3/4"	5/8"	30"
x73	13 5/8"	14 5/8"	1/2"	30"
HP 12x84	12 1/4"	12 1/4"	11/16"	24"
x74	12 1/8"	12 1/4"	5/8"	24"
x63	12"	12 1/8"	1/2"	24"
x53	11 3/4"	12"	7/16"	24"
HP 10x57	10"	10 1/4"	9/16"	24"
x42	9 3/4"	10 1/8"	7/16"	24"
HP 8x36	8"	8 1/8"	7/16"	18"

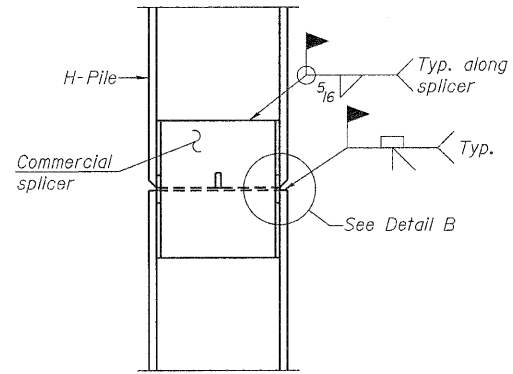

ELEVATION

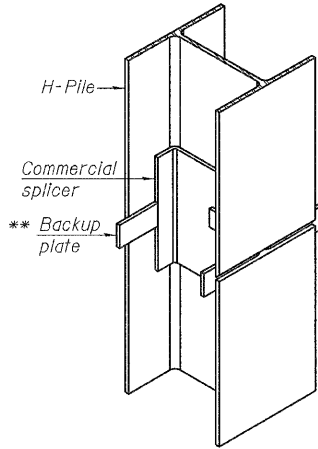

ISOMETRIC VIEW

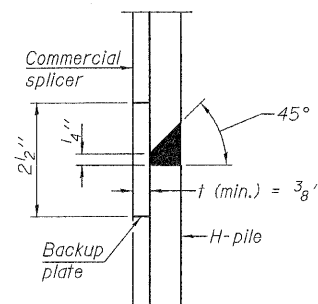

DETAIL "B"

WELDED COMMERCIAL SPLICE

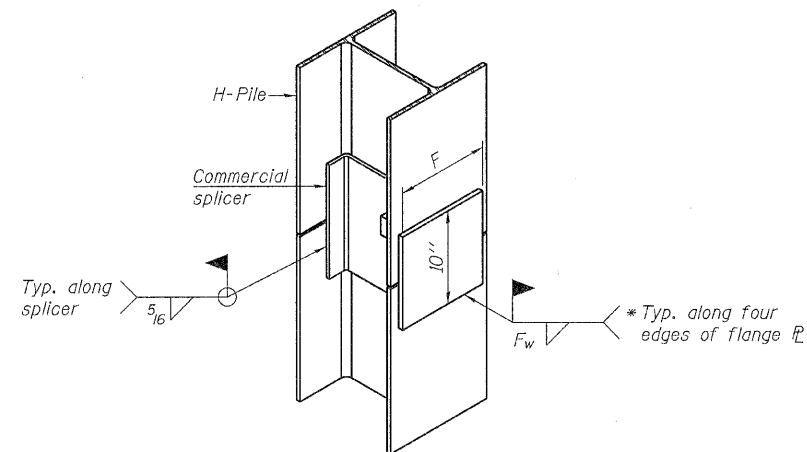

ISOMETRIC VIEW

WELDED COMMERCIAL SPLICE ALTERNATE

- * Interrupt welds 1/4" from end of web and/or each flange.
- ** Remove portions of backup plates that extend outside the flanges.
- *** Weld size per pile shoe manufacturer (5/16" min.).

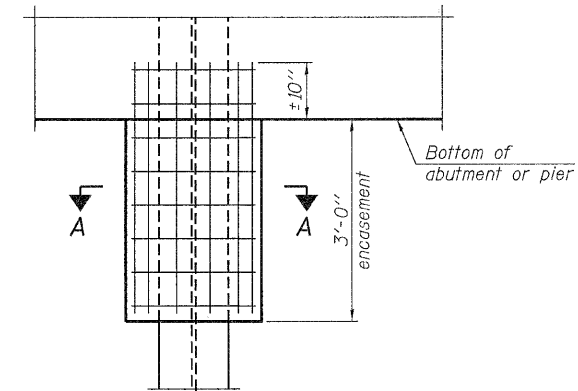

ELEVATION

PILE ENCASEMENT

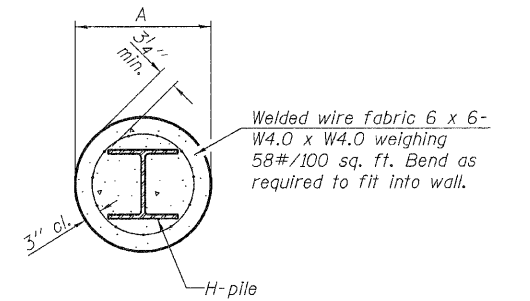

SECTION A-A

Note:
Forms for encasement may be omitted when soil conditions permit.

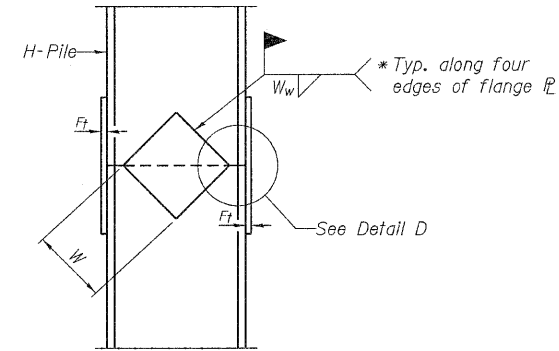

ELEVATION

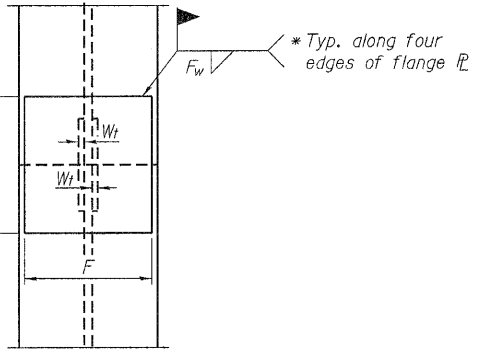

END VIEW

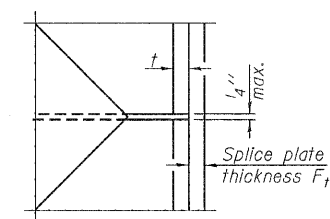

DETAIL D

WELDED PLATE FIELD SPLICE

Designation	F	F _t	F _w	W	W _t	W _w
HP 14x117	12 1/2"	1"	7/8"	7 3/4"	5/8"	1/2"
x102	12 1/2"	7/8"	3/4"	7 3/4"	5/8"	1/2"
x89	12 1/2"	3/4"	11/16"	7 3/4"	5/8"	1/2"
x73	12 1/2"	5/8"	9/16"	7 3/4"	5/8"	1/2"
HP 12x84	10"	7/8"	11/16"	6 1/2"	5/8"	1/2"
x74	10"	7/8"	11/16"	6 1/2"	5/8"	1/2"
x63	10"	5/8"	1/2"	6 1/2"	1/2"	3/8"
x53	10"	5/8"	1/2"	6 1/2"	1/2"	3/8"
HP 10x57	8"	3/4"	9/16"	5 1/4"	1/2"	3/8"
x42	8"	5/8"	9/16"	5 1/4"	1/2"	3/8"
HP 8x36	7"	5/8"	7/16"	4 1/4"	1/2"	3/8"

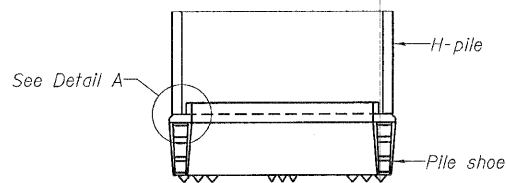

ELEVATION

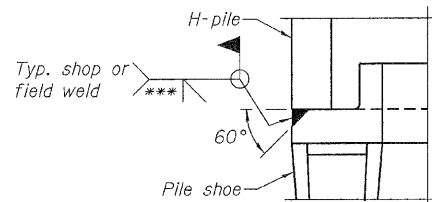

DETAIL A

H-PILE SHOE ATTACHMENT

DESIGNED - A.S.L.
CHECKED - S.W.M.
DRAWN - D.A.B.
CHECKED - S.W.M.

F-HP 11-1-09

Note:
The steel H-piles shall be according to AASHTO M270 Grade 50.

**HP PILE DETAILS
STRUCTURE NO. 024-3138**

HAMPTON, LENZINI AND RENWICK, INC. CIVIL ENGINEERS - STRUCTURAL ENGINEERS - LAND SURVEYORS 3085 STEVENSON DRIVE, SUITE 201 SPRINGFIELD, ILLINOIS 62703 217.546.3400 www.hirengineering.com <small>104.000999 ILLINOIS PROFESSIONAL DESIGN FIRM LS / PE / SE CORPORATION</small>	SHEET NO. 7	T.R.	SECTION	COUNTY	TOTAL SHEETS	SHEET NO.
	8 SHEETS	185	07-06115-00-BR	EDWARDS	12	11
PROJECT NUMBER: 09.0007.130	DATE: 02/23/10	ROAD DISTRICT #6		CONTRACT NO. 95633		
		FED. ROAD DIST. NO.	ILLINOIS	FED. AID PROJECT		

