

STATE OF ILLINOIS
DEPARTMENT OF TRANSPORTATION

F.A. RTE.	SECTION	COUNTY	TOTAL SHEETS	SHEET NO.
VAR.	2021-091-CBL	VARIOUS	13	1
FED. ROAD DIST. NO. 1	ILLINOIS	CONTRACT NO. 62P21		

FOR INDEX OF SHEETS, SEE SHEET NO. 2

PROPOSED HIGHWAY PLANS

VARIOUS ROUTES (I-55, I-57, I-80 & IL 394)
 AT VARIOUS EXPRESSWAY MEDIANS
 SECTION: 2021-091-CBL
 HIGH TENSION CABLE BARRIER REPAIR
 VARIOUS COUNTIES
 C-91-219-21

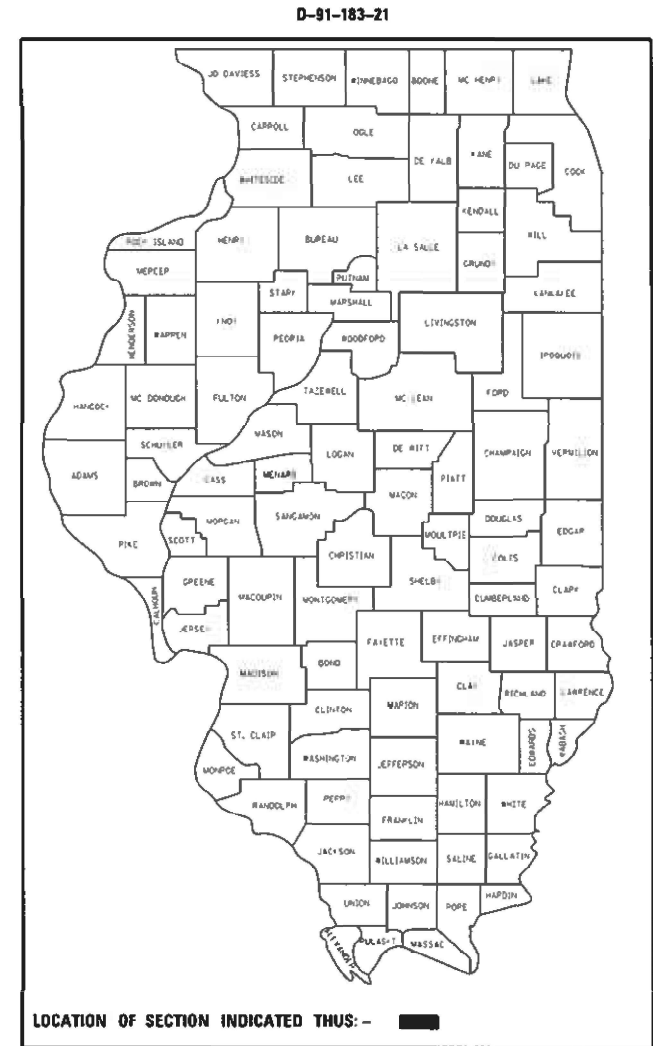

SEE LOCATION MAP
SHEET 4

J.U.L.I.E.
 JOINT UTILITY LOCATION INFORMATION FOR EXCAVATION
 1-800-892-0123
 OR 811

PROJECT MANAGER: J. ALAIN MIDY (847) 221-3056

CONTRACT NO. 62P21

STATE OF ILLINOIS
 DEPARTMENT OF TRANSPORTATION

SUBMITTED May 13, 2021
Jose Pires / CWS
 REGIONAL ENGINEER

June 25, 2021
Scott A. Etk
 ENGINEER OF DESIGN AND ENVIRONMENT

June 25, 2021
James J. Gu
 DIRECTOR OF HIGHWAYS PROJECT IMPLEMENTATION 13

PRINTED BY THE AUTHORITY
OF THE STATE OF ILLINOIS

INDEX OF SHEETS

STATE STANDARDS

GENERAL NOTES

<u>SHEET NO.</u>	<u>DESCRIPTION</u>	<u>STANDARD NO.</u>	<u>DESCRIPTION</u>
1	COVER SHEET	635001-02	DELINEATORS
2	INDEX OF SHEETS, STANDARDS AND GENERAL NOTES	701101-05	OFF-ROAD OPERATIONS, MULTILANE, 15' TO 24" FROM PAVEMENT EDGE
3	SUMMARY OF QUANTITIES	701106-02	OFF-ROAD OPERATIONS, MULTILANE, > 15' AWAY
4	LOCATION MAP	701400-10	APPROACH TO LANE CLOSURE, FREEWAY/EXPRESSWAY
5-6	HIGH TENSION GUARDRAIL DETAILS (BRIFEN USA)	701401-12	LANE CLOSURE, FREEWAY/EXPRESSWAY
7	HIGH TENSION GUARDRAIL DETAILS (GIBLARTAR)	701411-09	LANE CLOSURE, MULTILANE, AT ENTRANCE OR EXIT RAMP FOR SPEEDS ≥ 45 MPH
8	HIGH TENSION GUARDRAIL DETAILS (TRINITY)	701421-08	LANE CLOSURE, MULTILANE, DAY OPERATIONS ONLY, FOR SPEEDS ≥ 45 MPH TO 55 MPH
9	ENTRANCE RAMP AND CLOSURE DETAILS (TC-08)	701426-09	LANE CLOSURE, MULTILANE, INTERMITTENT OR MOVING OPERATIONS, FOR SPEEDS ≥ 45 MPH
10	TRAFFIC CONTROL AND PROTECTION FOR SIDE ROADS, INTERSECTIONS AND DRIVEWAYS (TC-10)	701428-01	TRAFFIC CONTROL SETUP AND REMOVAL FREEWAY/EXPRESSWAY
11	TRAFFIC CONTROL AND PROTECTION AT TURN BAYS (TO REMAIN OPEN TO TRAFFIC) (TC-14)	701901-08	TRAFFIC CONTROL DEVICES
12	HIGHWAY TRAFFIC CONTROL FOR FREEWAY SHOULDER CLOSURES AND PARTIAL RAMP CLOSURES (TC-17)		
13	SIGNING FOR FLAGGING OPERATIONS AT WORK ZONE OPENINGS (TC-18)		

BEFORE STARTING ANY EXCAVATION, THE CONTRACTOR SHALL CALL "J.U.L.I.E." AT (800) 892-0123 OR 811 FOR FIELD LOCATIONS OF BURIED ELECTRIC, TELEPHONE AND GAS UTILITIES. 48 HOUR NOTIFICATION IS REQUIRED.

THE CONTRACTOR SHALL COORDINATE CONSTRUCTION ACTIVITIES WITH UTILITY COMPANIES.

THE CONTRACTOR WILL NOT BE ALLOWED TO SET UP A YARD OR FIELD OFFICE ON STATE PROPERTY WITHOUT WRITTEN PERMISSION FROM THE DEPARTMENT.

THE CONTRACTOR SHALL CALL STATE ELECTRICAL CONTRACTOR AT (773) 287-7600 TO LOCATE STATE OWNED FACILITIES.

THE CONTRACTOR SHALL WORK IN THE DIRECTION OF TRAFFIC.

THE CONTRACTOR WILL NOT BE ALLOWED TO STORE MATERIALS OVERNIGHT IN THE MEDIAN.

THE PROPOSED DEPTH OF THE CONCRETE SOCKETED FOUNDATIONS SHALL BE 42" (MINIMUM).

STANDARDS 701400 & 701401 SHALL BE USED FOR ALL LANE CLOSURES EXCEPT ON IL 394 SOUTH OF SAUK TRAIL, WHERE STANDARD 701421 SHALL BE USED.

CONTRACTOR SHALL REGISTER, SUBMIT AND GAIN THE APPROVAL FOR ALL DAILY LANE CLOSURE REQUESTS VIA WWW.IDOTLCS.COM AT LEAST 24 HOURS IN ADVANCE OF ALL WORK.



THE CONTRACTOR SHALL NOTIFY THE ILLINOIS DEPARTMENT OF TRANSPORTATION, EXPRESSWAY TRAFFIC CONTROL SUPERVISOR (847-705-4151) 72 HOURS IN ADVANCE OF ALL WORK ON THE INTERSTATE.

FILE NAME =	USER NAME = midyja	DESIGNED -	REVISED -	STATE OF ILLINOIS DEPARTMENT OF TRANSPORTATION	CABLE BARRIER REPAIR AT VARIOUS EXPRESSWAY MEDIANS INDEX OF SHEETS, STATE STANDARDS & GENERAL NOTES	F.A. RTE.	SECTION	COUNTY	TOTAL SHEETS	SHEET NO.	
pw:\plenroom.dot.illinois.gov\PIDOT\Documents\IDOT Offices\District 1\Projects\DI34318\DRAWING\Design\DI34318-sht-plen.dgn	DRAWN	CHECKED -	REVISED -			VAR.	2021-091-CBL	VARIOUS	13	2	
PLOT SCALE = 100.0000' / in.		DATE -	REVISED -			SCALE: SHEET NO. OF SHEETS STA. TO STA.					
PLOT DATE = 5/13/2021						FED. ROAD DIST. NO. 1 ILLINOIS FED. AID PROJECT					

REV-SEP

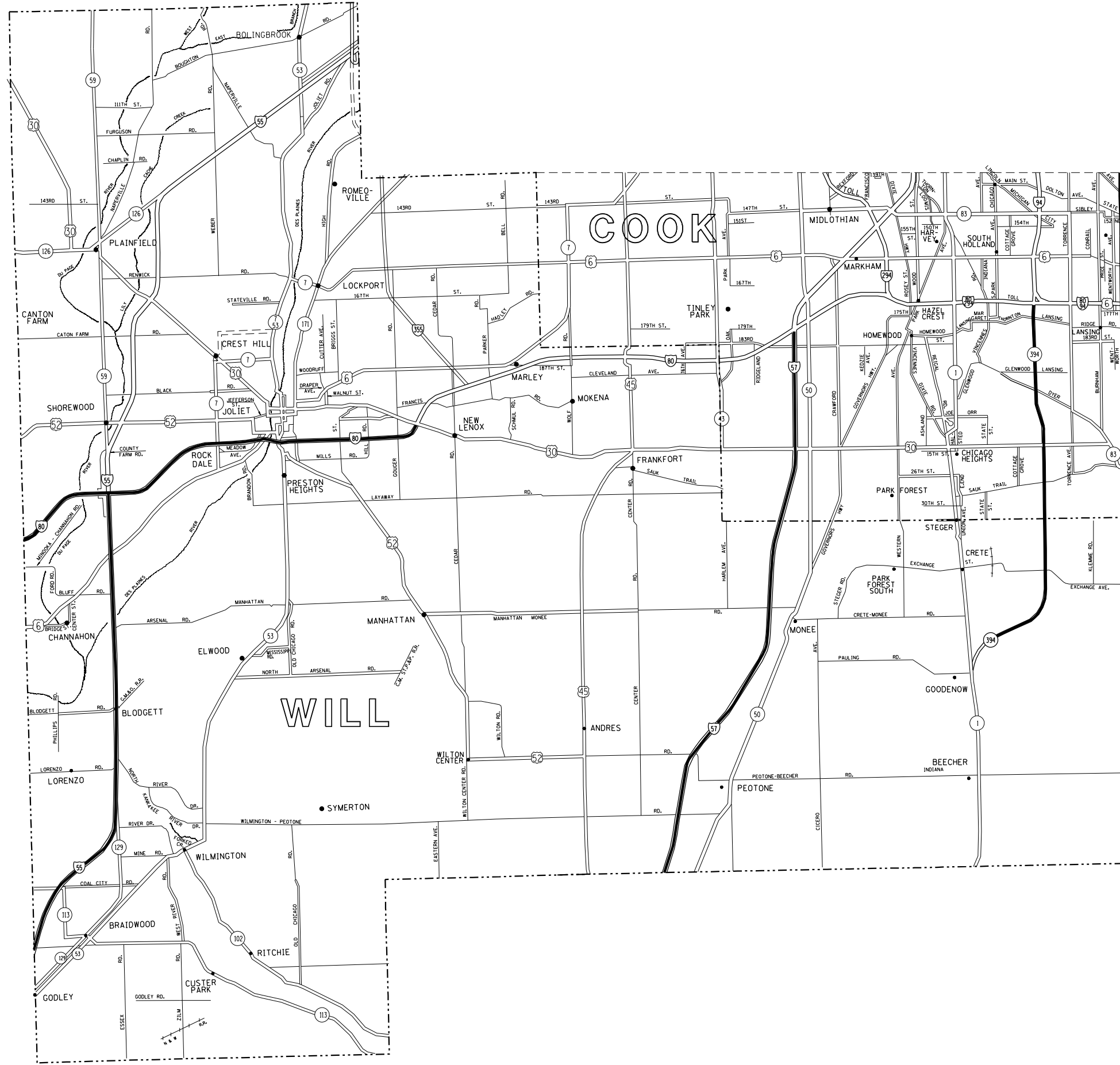
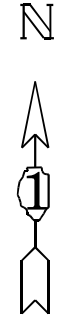
CONTRACT NO. 62P21



- LEGEND**
-  STATE HIGHWAYS & EXPRESSWAYS WITH EXISTING HIGH TENSION BARRIERS.
 -  STATE HIGHWAYS & EXPRESSWAYS WITHIN STATE JURISDICTION. (EXCEPT TOLLWAYS)
 -  VARIOUS AGENCIES HIGHWAYS

FILE NAME =	USER NAME = midjje	DESIGNED -	REVISED -
p:\planroom.dot\illinois.gov\PIDOT\Documents\DOT Offices\District 1\Projects\0134318\DRAWING\Design\0134318-sht-plen.dgn		DRAWN -	REVISED -
	PLOT SCALE = 100.0000' / in.	CHECKED -	REVISED -
	PLOT DATE = 5/13/2021	DATE -	REVISED -

**STATE OF ILLINOIS
DEPARTMENT OF TRANSPORTATION**

**CABLE BARRIER REPAIR
AT VARIOUS EXPRESSWAY MEDIANS
WILL & COOK (SOUTH) COUNTIES LOCATION MAP**

SCALE: SHEET NO. 7 OF 7 SHEETS STA. TO STA.

F.A. RTE.	SECTION	COUNTY	TOTAL SHEETS	SHEET NO.
VAR.	2021-091-CBL	VARIOUS	13	4
			CONTRACT NO. 62P21	
FED. ROAD DIST. NO. 1 ILLINOIS FED. AID PROJECT				

FOR INFORMATION ONLY

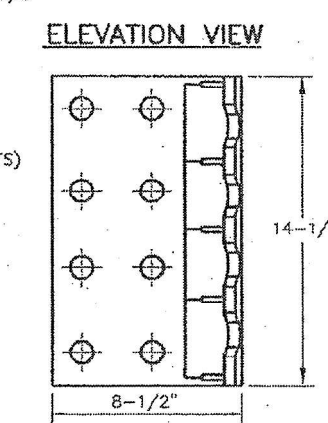
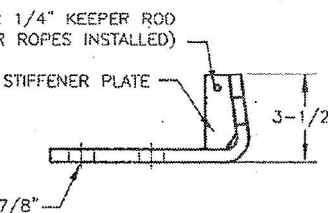
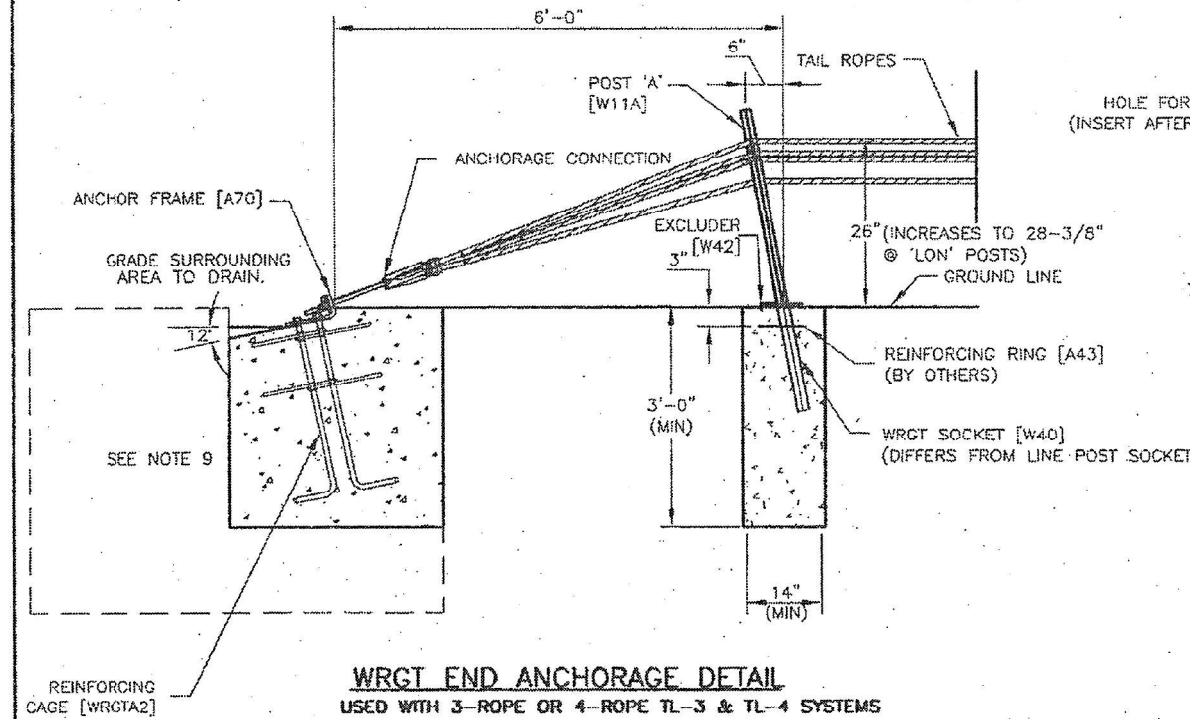
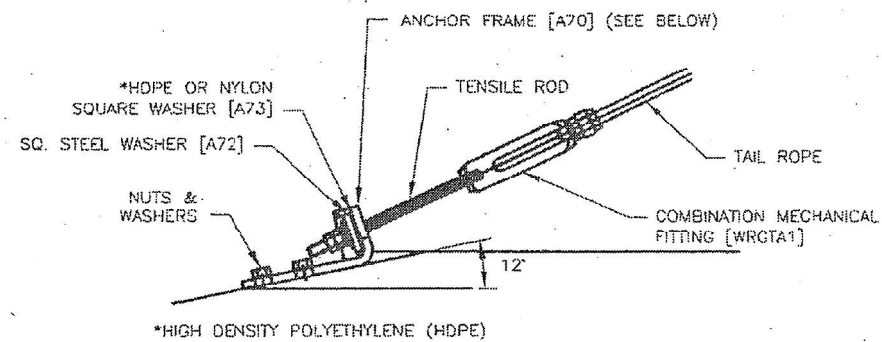
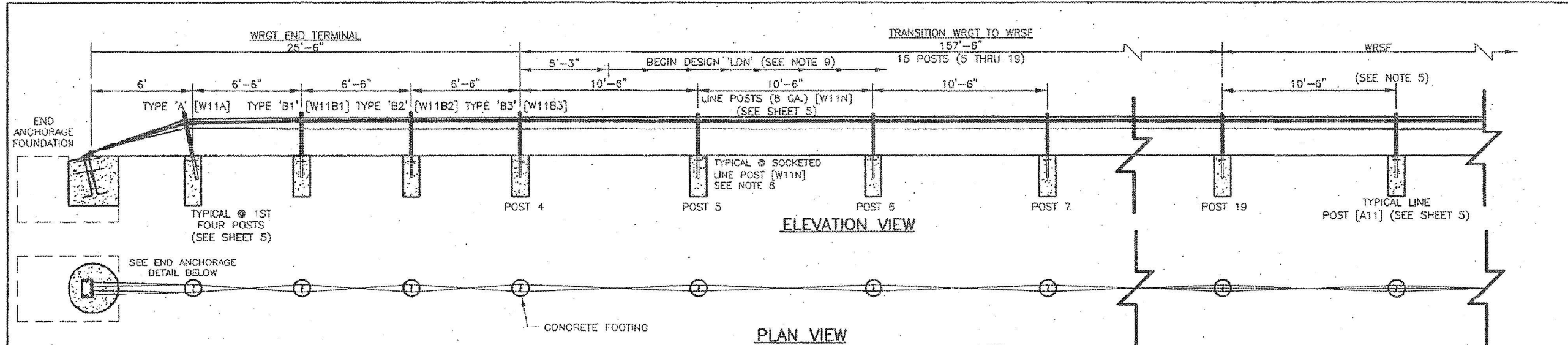

NOTES:

- BRIFEN DRAWINGS, SPECIFICATIONS & PRODUCT MANUAL SHOULD BE REVIEWED PRIOR TO STARTING AN INSTALLATION. FOR ASSISTANCE OR ADDITIONAL INFORMATION CALL 1-866-427-4336 TOLL FREE.
- WIRE ROPE SAFETY FENCE (WRSF) IS RECOMMENDED FOR INSTALLATIONS ON SLOPES OF 6:1 OR FLATTER. THE AREA SHOULD BE RELATIVELY SMOOTH, WITHOUT EDGE DROP-OFFS, ABRUPT SLOPE CHANGES, Holes, DEBRIS, ETC. THAT COULD PREVENT A VEHICLE FROM IMPACTING THE WRSF WITH ALL WHEELS ON THE GROUND, AND SUSPENSION NORMAL. SOME FILLING AND/OR GRADING AND COMPACTION MAY BE NECESSARY. THE ROPES MUST BE PLACED AT DESIGN HEIGHT ABOVE GROUND LINE. TOLERANCE IS $\pm 1"$.
- WRSF MAY BE INSTALLED ON EITHER SIDE OF THE ROADWAY. THE RADIUS EDGE OF POSTS SHALL BE ON THE APPROACH SIDE OF TRAFFIC. WEAKENING CUT (RELIEF NOTCH) AT GROUND LINE ON POST A & B TO BE PLACED TOWARD THE END ANCHOR. ALSO SEE SHEET 5.
- ALL POSTS ARE SET IN SOCKETS UNLESS OTHERWISE SPECIFIED. ALL CONCRETE (BY OTHERS) TO BE 3500 PSI MINIMUM. EXPOSED SURFACES TO BE HAND TROWELED.
- LINE POST SPACING AT 10'-6" SHOWN; MAY BE DECREASED IF NECESSARY. ADEQUATE CLEARANCE TO RIGID OBSTACLES SUCH AS BRIDGE PIERS, SIGN SUPPORTS, POWER POLES, TREES, ETC. IS CRITICAL. SEE PRODUCT MANUAL OR CONTACT MANUFACTURER.
- WRGT END TERMINAL IS NCHRP 350 APPROVED AND MAY BE LOCATED WITHIN THE HORIZONTAL CLEAR ZONE. END TERMINAL FLARE RATE MAY NOT EXCEED 25:1; 50:1 OR LESS IS PREFERRED. USED FOR BOTH TL-3 & TL-4 SYSTEMS. NO MAXIMUM LIMIT TO LENGTH BETWEEN END TERMINALS.
- WRGT END TERMINAL IS SUPPLIED AS A PACKAGE UNLESS SPECIFIED OTHERWISE. INCLUDES ANCHOR FRAME, REINFORCING CAGE, CONNECTION HARDWARE, COMBINATION MECHANICAL FITTING, POSTS TYPE A AND B, WRGT SOCKETS, PEGS, EXCLUDERS AND TAIL ROPES.
- THE 15 TRANSITION LINE POSTS ADJACENT TO WRGT END TERMINAL DO NOT HAVE TOP ROPE SLOT. ALL THE ROPES WEAVE ON EITHER SIDE OF THE POSTS UNTIL THE FIRST LINE POST WITH A SLOT (POST 20). SEE SHEET 5.
- END ANCHORAGE AND POST FOUNDATION SIZES ARE DETERMINED BY SOIL CLASSIFICATION AND CONDITION AS WELL AS TEMPERATURE EXTREMES. REFER TO PRODUCT MANUAL OR CONTACT BRIFEN USA REPRESENTATIVE FOR TECHNICAL ASSISTANCE.

BRIFEN★USA INC.

Revisions			GENERAL LAYOUT		
No.	Date	By	USING WRGT END TERMINAL (NCHRP-350) AND TRANSITION		
1.	7.21.05	MW	Date	Drawn By	Scale
2.	8.01.05	MW	5.17.05	Manita Workman	None
3.	8.04.05	MW	VERSION 8.8		
4.	10.10.05	MW			
5.	12.16.05	MW	Dwg. No.	WRSF-05-2016	

FOR INFORMATION ONLY

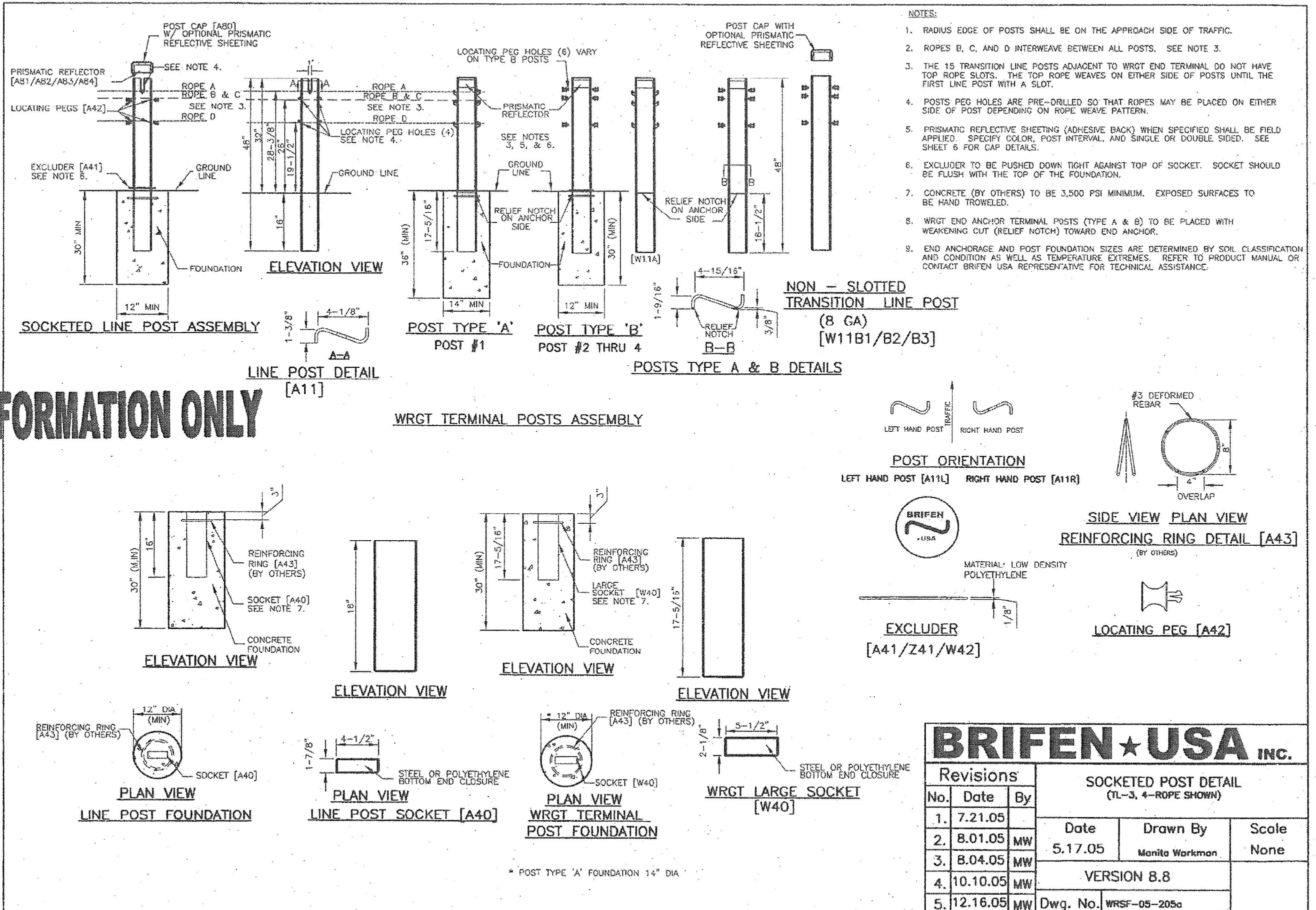

- NOTES:**
- RADIUS EDGE OF POSTS SHALL BE ON THE APPROACH SIDE OF TRAFFIC.
 - ROPES B, C, AND D INTERWEAVE BETWEEN ALL POSTS. SEE NOTE 3.
 - THE 15 TRANSITION LINE POSTS ADJACENT TO WRGT END TERMINAL DO NOT HAVE TOP ROPE SLOTS. THE TOP ROPE WEAVES ON EITHER SIDE OF POSTS UNTIL THE FIRST LINE POST WITH A SLOT.
 - POSTS PEG HOLES ARE PRE-DRILLED SO THAT ROPES MAY BE PLACED ON EITHER SIDE OF POST DEPENDING ON ROPE WEAVE PATTERN.
 - PRISMATIC REFLECTIVE SHEETING (ADHESIVE BACK) WHEN SPECIFIED SHALL BE FIELD APPLIED. SPECIFY COLOR, POST INTERVAL, AND SINGLE OR DOUBLE SIDED. SEE SHEET 6 FOR CAP DETAILS.
 - EXCLUDER TO BE PUSHED DOWN TIGHT AGAINST TOP OF SOCKET. SOCKET SHOULD BE FLUSH WITH THE TOP OF THE FOUNDATION.
 - CONCRETE (BY OTHERS) TO BE 3,500 PSI MINIMUM. EXPOSED SURFACES TO BE HAND TROWELED.
 - WRGT END ANCHOR TERMINAL POSTS (TYPE A & B) TO BE PLACED WITH WEAKENING CUT (RELIEF NOTCH) TOWARD END ANCHOR.
 - END ANCHORAGE AND POST FOUNDATION SIZES ARE DETERMINED BY SOIL CLASSIFICATION AND CONDITION AS WELL AS TEMPERATURE EXTREMES. REFER TO PRODUCT MANUAL OR CONTACT BRIFEN USA REPRESENTATIVE FOR TECHNICAL ASSISTANCE.



BRIFEN USA INC.

Revisions			SOCKETED POST DETAIL (TL-3, 4-ROPE SHOWN)		
No.	Date	By	Date	Drawn By	Scale
1.	7.21.05		5.17.05	Monita Workman	None
2.	8.01.05	MW			
3.	8.04.05	MW	VERSION 8.8		
4.	10.10.05	MW			
5.	12.16.05	MW	Dwg. No.	WRSF-05-205a	

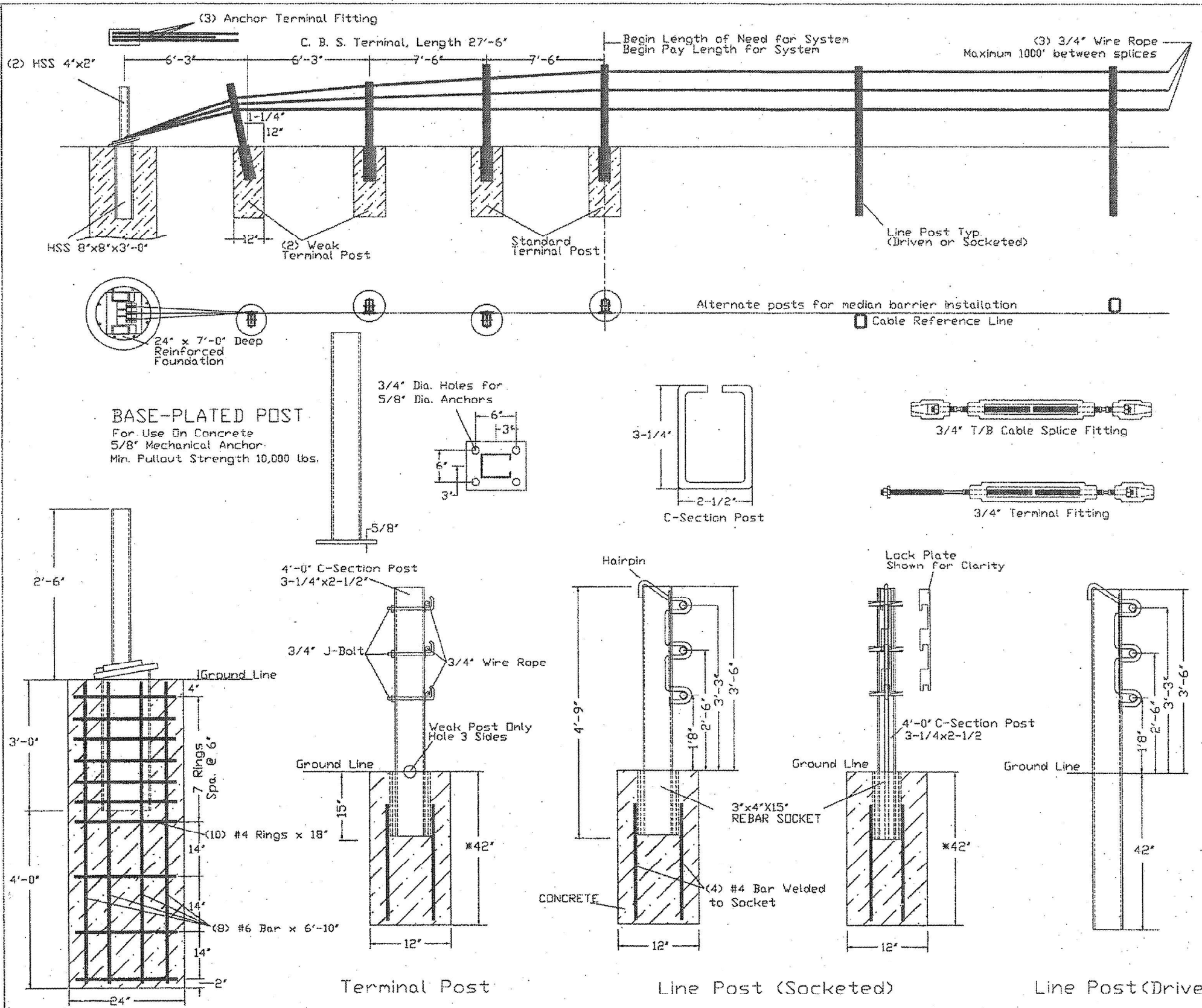

- ### GENERAL NOTES
- For additional information contact Gibraltar, Inc. at 1-800-495-8957, or see the manufacturer's product manual.
 - All concrete shall be minimum 2500 PSI.
 - Alternate Post for bi-directional traffic flow. If installed for traffic in one direction install cables on traffic side of posts.
 - The Cable Barrier System shall be installed on shoulders or on medians with slopes of 6:1 or flatter. If installed on slopes steeper than 6:1 up to 4:1 the TL-4 system performs as a TL-3 and Gibraltar must be contacted for various guidelines related to placement.
 - The Cable Barrier System is accepted by the FHWA Test Level - 4
 - See the MUTCD for proper "Barrier" delineation
 - Rock Clause: Where solid rock is encountered:
 - For socketed post, continue digging 12" diameter, 15' deep into rock or the required plan depth, whichever comes first.
 - For driven post, core drill a 4" diameter hole 18" deep into rock or the required plan depth, whichever comes first.
 - For Anchor post, continue digging 24" diameter, 30' deep into rock or the required plan depth, whichever comes first.
 - The Gibraltar cable barrier system shall be installed in NCHRP Report 350 standard compacted soil. Soil must be well drained.
 - Every component to be galvanized.

Cable Tension	
-10F	8000
0	7600
10	7200
20	6800
30	6400
40	6000
50	5600
60	5200
70	4800
80	4400
90	4000
100	3600
110	3200

Allowable Deviation from Chart +/- 10%

Deflection	Post Spacing
9'3"	30.FT
9'	28.FT
8'	20.FT
7'	12.FT
6'8"	10.FT

Cable Release Anchor Post

*30"x12" Concrete Foundation with Min. 18" wide Mow Strip
 *42"x12" Deep w/o Mow Strip

FOR INFORMATION ONLY

GIBRALTAR
 320 Southland Road
 Burnet, Texas 78611
 1-800-495-8957

Cable Barrier System
 Patent Pending

SYSTEM: TL-4 SCALE: NTS DRAFTERS: EJ&TJ DATE: 09/13/07

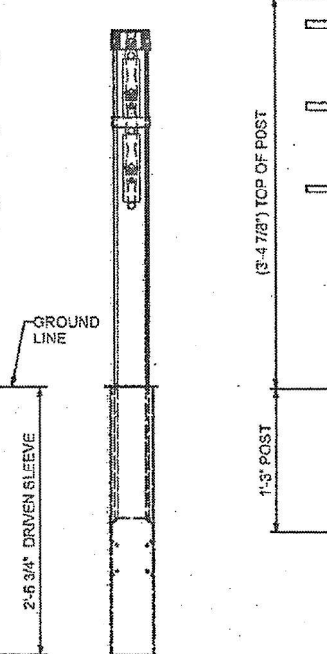
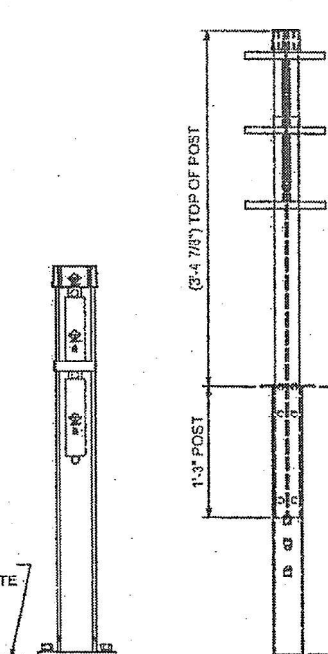
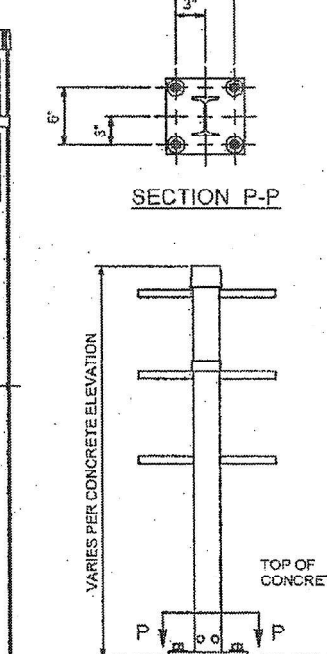
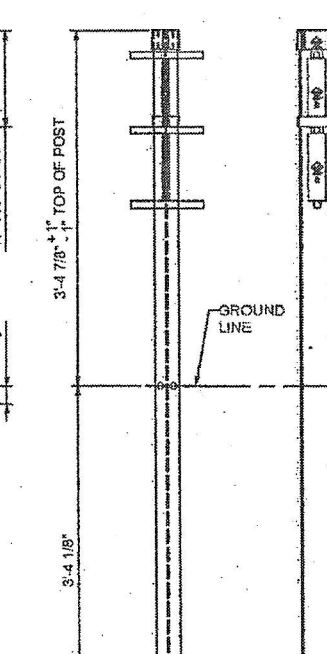
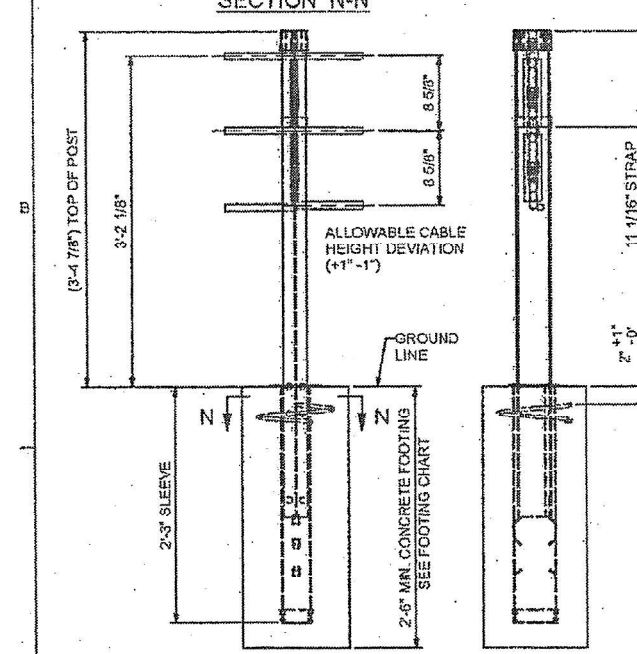
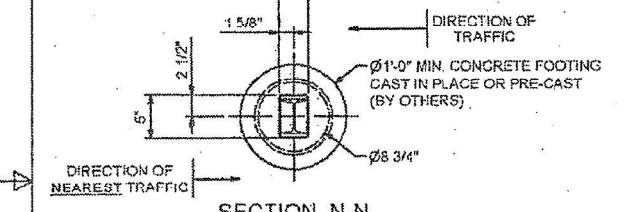
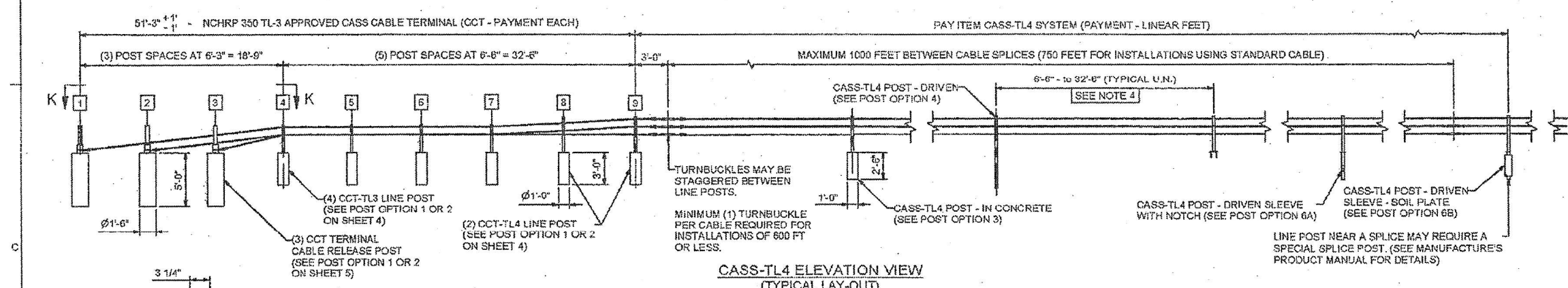
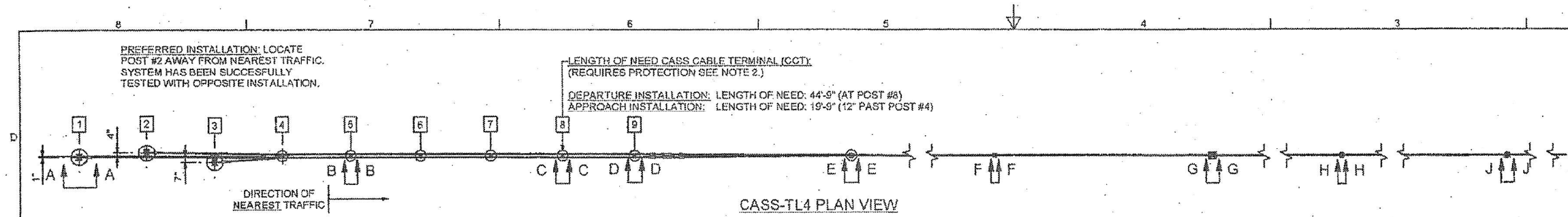

FOR INFORMATION ONLY

- NOTES:**
- CASS-TL4 HAS BEEN SUCCESSFULLY TESTED TO NATIONAL COOPERATIVE HIGHWAY RESEARCH PROGRAM REPORT 350 TEST LEVEL 4 (NCHRP 350 TL4) AND ACCEPTED BY FHWA FOR VARIOUS POST SPACINGS. CASS CABLE TERMINAL (CCT) HAS BEEN SUCCESSFULLY TESTED AND APPROVED TO NCHRP TL3.
 - AN NCHRP 350 TL3 APPROVED TERMINAL (CCT) OR CASS-TL4 TRANSITION (VARIOUS) SHALL BE USED ON APPROACH AND DEPARTURE TERMINATIONS WHEN CASS-TL4 IS INSTALLED ON THE NATIONAL HIGHWAY SYSTEM (NHS). IF THE TERMINATION POINT IS LOCATED OUTSIDE THE CLEAR ZONE AND/OR PROTECTED BY OTHER MEANS (CRASHWORTHY BARRIER, TERMINALS, ETC.), A NON-NCHRP 350 TL3 ANCHOR (CCA) MAY BE USED ON APPROACH AND DEPARTURE TERMINATIONS.
 - CASS-TL4 SHALL BE INSTALLED ON SHOULDERS OR MEDIANS WITH SLOPES OF 6:1 OR FLATTER WITHOUT OBSTRUCTIONS, DEPRESSIONS, ETC. THAT MAY SIGNIFICANTLY AFFECT THE STABILITY OF AN ERRANT VEHICLE. GRADING OF SITE AND/OR APPROPRIATE FILL MATERIALS MAY BE REQUIRED. THE DESIGNER/INSTALLER SHALL "FLATTEN" OR "ROUND" VARIOUS TOPOGRAPHICAL INCONSISTENCIES THAT COULD INTERFERE WITH THE ABILITY OF THE INSTALLER TO CONSISTENTLY MAINTAIN THE DESIGN HEIGHT (IN RELATION TO THE TERRAIN) OF THE CABLES. PLEASE CONSULT THE CASS MANUAL(S) FOR INSTALLATIONS IN "DITCH SECTIONS".
 - CASS-TL4 POST SPACING MAY BE MODIFIED TO AVOID OBSTACLES THAT CONFLICT WITH THE INSTALLATION OF CASS-TL4 LINE POSTS. NO POST SPACE CAN EXCEED THE MAXIMUM POST SPACE LIMIT OF 32'-0", OR MAXIMUM POST SPACING ALLOWED BY PROJECT ENGINEER - WHICHEVER IS LESS. REDUCING OR INCREASING POST SPACING AFFECTS DEFLECTION. CASS-TL4 MAY BE LATERALLY TRANSFERRED AT A RATE NOT TO EXCEED 30:1.
 - POST FOUNDATIONS MAY BE DRILLED THROUGH EXISTING PAVEMENT. TRINITY MAY ALLOW THE USE OF ALTERNATE LINE POST FOOTINGS IF SYSTEM IS INSTALLED WITH AN ACCEPTABLE MOWSTRIP APPLICATION - PLEASE CONTACT TRINITY.
 - FOR AESTHETIC PURPOSES TRINITY RECOMMENDS ALL SLEEVES, DRIVEN POSTS, AND LOWER CABLE RELEASE POSTS TO BE INSTALLED REASONABLY PLUMB (APPROXIMATELY 1/8" PER FOOT).
 - ALL CONCRETE SHALL HAVE A MINIMUM COMPRESSIVE STRENGTH OF 3,000 P.S.I. PRIOR TO TENSIONING THE SYSTEM. TRINITY RECOMMENDS THE CONCRETE TO BE VIBRATED IN ACCORDANCE WITH THE LATEST APPLICABLE AGENCY SPECIFICATION.
 - CASS-TL4 SHALL BE INSTALLED IN WELL-DRAINED, COMPACTED, NCHRP REPORT 350 STANDARD SOILS. IF SOIL DOESN'T MEET THIS CLASSIFICATION, IF SOLID ROCK/CONCRETE IS ENCOUNTERED BELOW GRADE OR IF SOIL IS SUSCEPTIBLE TO SEVERE FREEZE/THAW CYCLES, PLEASE CONTACT TRINITY ABOUT ALTERNATE FOOTING DESIGN(S). TRINITY SUGGESTS THE USE OF "MOW STRIPS" FOR EROSION PREVENTION AND EASE OF MAINTENANCE / INSTALLATION.
 - PLEASE SEE SPECIFYING AGENCY (OR MUTCD) FOR PROPER "BARRIER" DELINEATION.
 - PLEASE CONTACT TRINITY OR CONSULT THE DESIGN, INSTALLATION, OR REPAIR MANUAL(S) FOR ADDITIONAL INFORMATION.

TRINITY HIGHWAY PRODUCTS, LLC. EMAIL: PRODUCT.INFO@TRIN.NET
 2525 STEMMONS FREEWAY DALLAS, TX 75207 PHONE: (800) 644-7976

MOW STRIP DETAIL*		CONCRETE FOOTING CHART			
MOW STRIP	DEPTH	WIDTH	FOOTING	TUBE SLEEVE	REBAR RING
NONE			30" MIN.	27" MIN.	YES
HMA	6" MIN.	3" MIN.	27" MIN.	15" MIN.	NO
HMA	8" MIN.	3" MIN.	24" MIN.	15" MIN.	NO
RC	3" MIN.	3" MIN.	24" MIN.	15" MIN.	NO

CHART DOES NOT APPLY TO TERMINAL POSTS 1 THRU 9
 * MOW STRIP OR PAVEMENT
 HMA = HOT MIX ASPHALT (NOT RECYCLED ASPHALT PAVEMENT)
 RC = REINFORCED CONCRETE (3,000 P.S.I. MINIMUM)

No.	CASS-TL4 POST OPTIONS
1	CCT - TERMINAL POST 1 - 9 - IN CONCRETE
2	CCT - TERMINAL POST 1 - 9 - WITH SOIL PLATE
3	CASS-TL4 POST - IN CONCRETE
4	CASS-TL4 POST - DRIVEN
5	CASS-TL4 POST - BASE-PLATED
6	CASS-TL4 POST - IN DRIVEN SLEEVE
	6A - DRIVEN SLEEVE - WITH NOTCH
	6B - DRIVEN SLEEVE - WITH SOIL PLATE

CASS-TL4 3-CABLE GUARDRAIL SAFETY SYSTEM

TRINITY HIGHWAY PRODUCTS, LLC

PROJ: CASS-TL4

SS-740 3

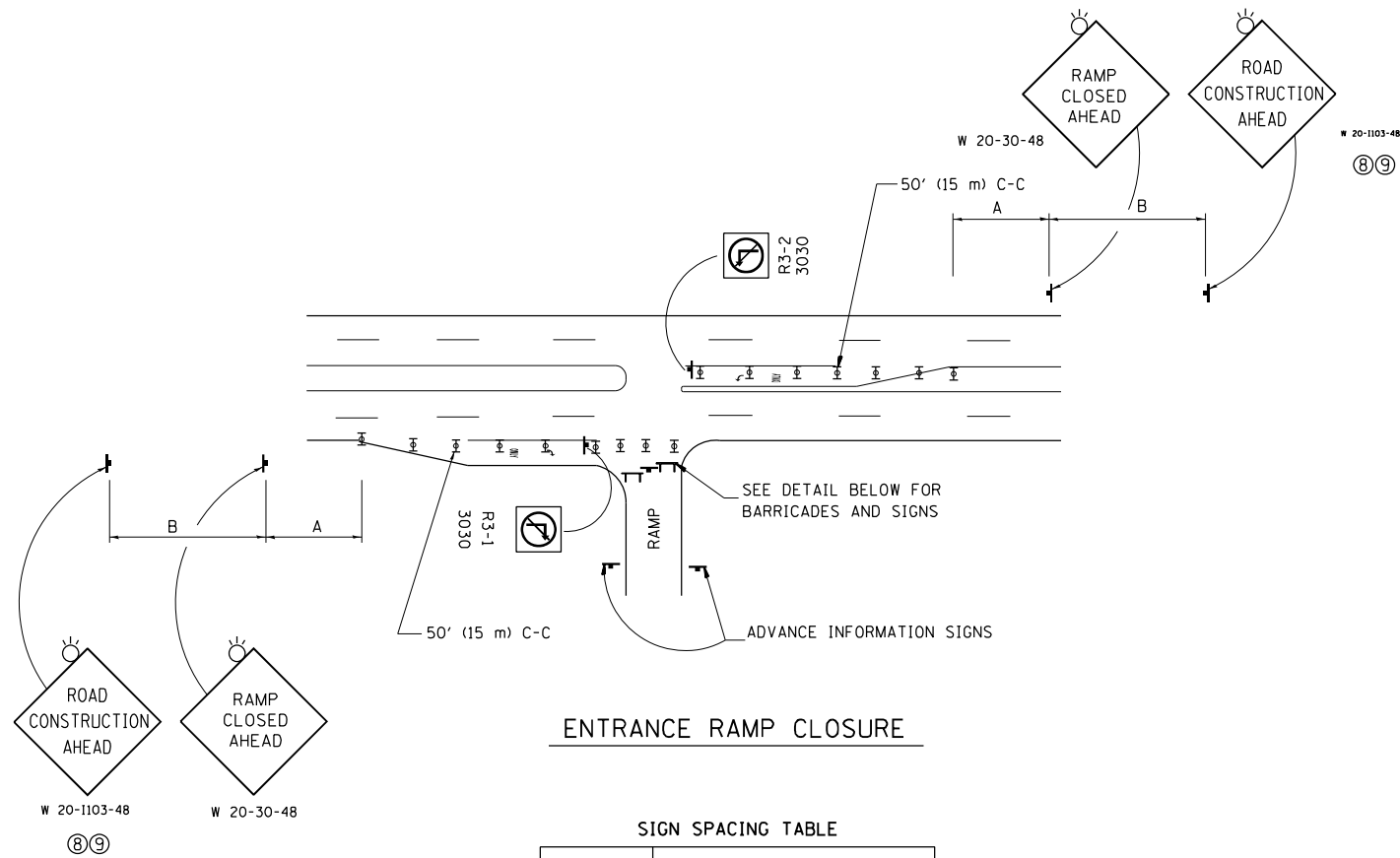

ENTRANCE RAMP CLOSURE

SIGN SPACING TABLE

FACILITY	DISTANCE BETWEEN SIGNS	
	A	B
EXPRESSWAY >24 HOURS	1000' (300 m)	1500' (450 m)
EXPRESSWAY <24 HOURS	500' (150 m)	500' (150 m)
ARTERIAL 55 MPH	500' (150 m)	500' (150 m)
ARTERIAL 50-45 MPH	350' (100 m)	350' (100 m)
ARTERIAL <45 MPH	200' (60 m)	200' (60 m)

DISTANCES MAY BE SHORTENED DEPENDING UPON THE PROXIMITY OF ADJACENT RAMPS OR INTERSECTIONS.

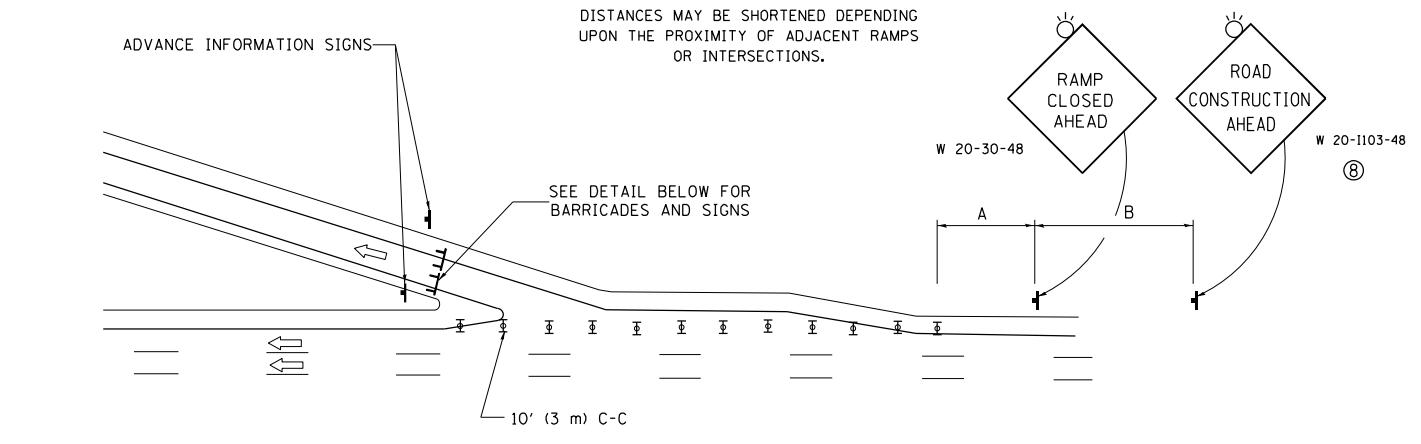

EXIT RAMP CLOSURE

- SYMBOLS**
- ⊥ TYPE II BARRICADE OR DRUM
 - ⊓ TYPE III BARRICADE WITH 2 FLASHING LIGHTS

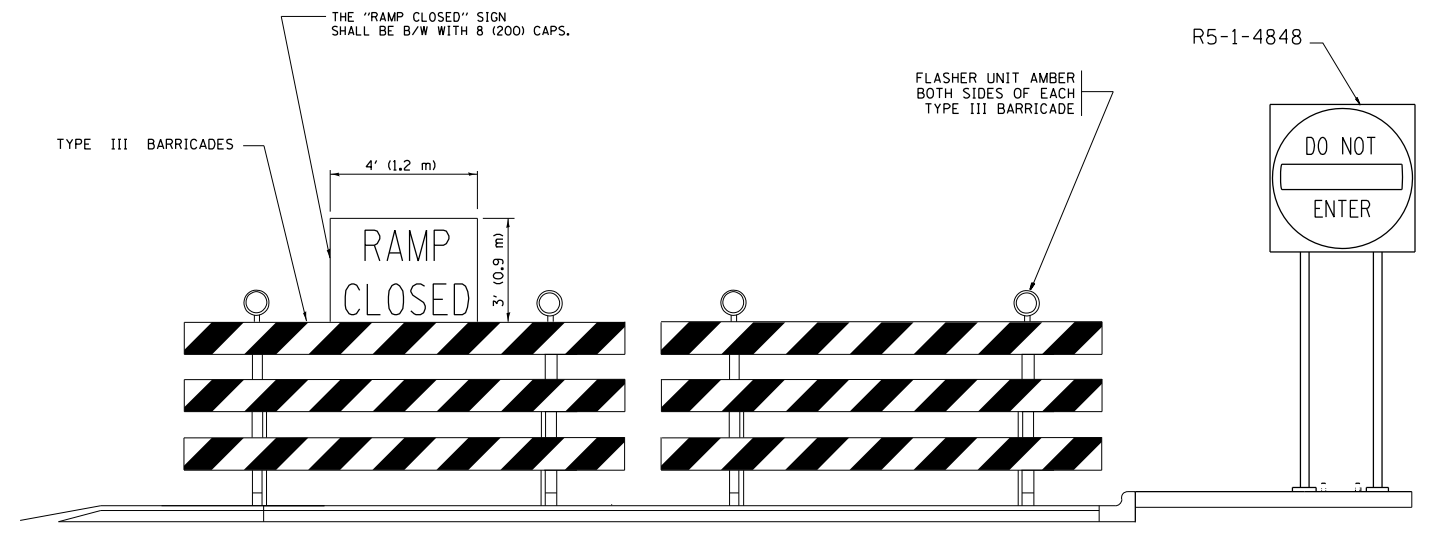

DETAIL FOR REQUIRED BARRICADES & SIGNS

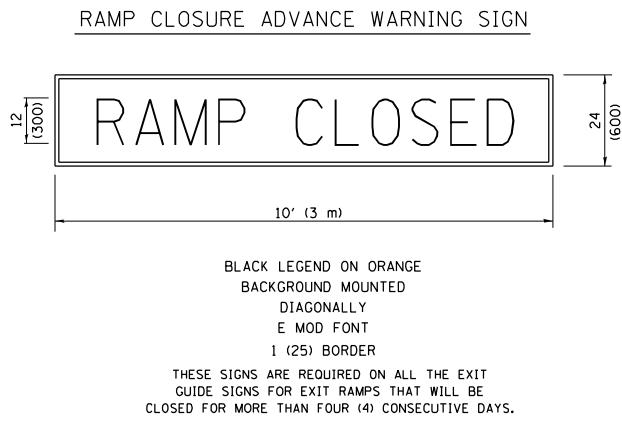

RAMP CLOSURE ADVANCE WARNING SIGN

BLACK LEGEND ON ORANGE BACKGROUND MOUNTED DIAGONALLY
E MOD FONT
1 (25) BORDER

THESE SIGNS ARE REQUIRED ON ALL THE EXIT GUIDE SIGNS FOR EXIT RAMPS THAT WILL BE CLOSED FOR MORE THAN FOUR (4) CONSECUTIVE DAYS.

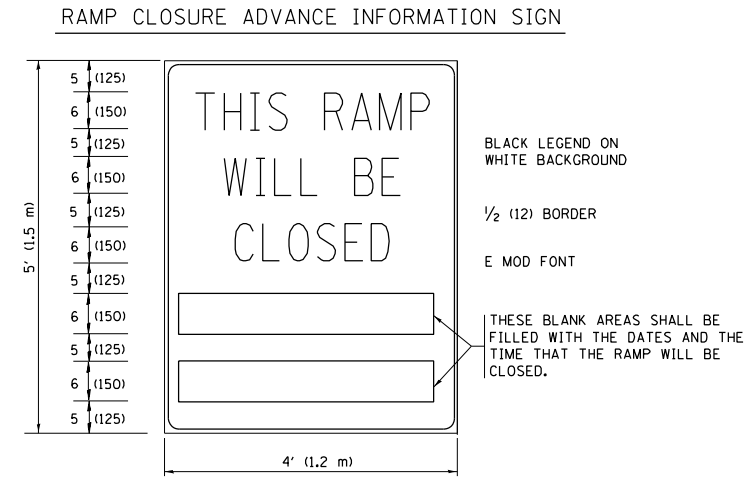

RAMP CLOSURE ADVANCE INFORMATION SIGN

BLACK LEGEND ON WHITE BACKGROUND
1/2 (12) BORDER
E MOD FONT

THESE BLANK AREAS SHALL BE FILLED WITH THE DATES AND THE TIME THAT THE RAMP WILL BE CLOSED.

THESE SIGNS ARE REQUIRED ON BOTH SIDES OF THE RAMP, MINIMUM OF 1 WEEK IN ADVANCE OF THE CLOSURE.
THESE SIGNS SHALL BE FABRICATED AND PAID FOR ACCORDING TO THE TEMPORARY INFORMATION SIGNING SPECIAL PROVISION

GENERAL NOTES:

- 1 CONES MAY BE SUBSTITUTED FOR DRUMS OR TYPE II BARRICADES DURING DAY OPERATIONS. CONES SHALL BE A MINIMUM OF 28 (700) HIGH.
- 2 VERTICAL BARRICADES SHALL NOT BE USED FOR RAMP CLOSURES.
- 3 A FLAGGER SHALL BE POSITIONED AT EACH CLOSED RAMP THAT IS OPEN TO CONSTRUCTION VEHICLES, PRECEDED BY A W20-7 FLAGGER WARNING SIGN.
- 4 ALL ROUTE MARKERS AND TRAILBLAZER ASSEMBLIES WHICH DIRECT MOTORISTS TO A CLOSED ENTRANCE RAMP SHALL BE COVERED WHEN THE RAMP IS CLOSED FOR MORE THAN FOUR (4) DAYS.
- 5 THE SIGNING AND BARRICADING WHICH IS REQUIRED BY THIS DETAIL SHALL BE INCLUDED IN THE COST OF TRAFFIC CONTROL AND PROTECTION (EXPRESSWAYS).
- 6 AUTHORIZATION FROM THE DISTRICT'S BUREAU OF TRAFFIC IS REQUIRED FOR ALL RAMP CLOSURES.
- 7 THE RAMP CLOSURE ADVANCE INFORMATION SIGNS SHALL BE ERECTED IF THE CLOSURE TIME EXCEEDS TWENTY-FOUR (24) HOURS. ADDITIONAL ADVANCE WARNING SIGNS ON EXIT GUIDE SIGNING WILL BE REQUIRED FOR EXIT RAMP CLOSURES THAT EXCEED FOUR (4) DAYS IN LENGTH.
- 8 ROAD CONSTRUCTION AHEAD SIGNS MAY BE OMITTED WHEN THIS DETAIL IS USED IN CONJUNCTION WITH OTHER TRAFFIC CONTROL THAT ALREADY INCLUDES A ROAD CONSTRUCTION AHEAD SIGN.
- 9 ARTERIAL ROAD CONSTRUCTION AHEAD SIGNS SHALL BE INSTALLED ON THE LEFT SIDE OF TRAFFIC IF THE MEDIAN IS MORE THAN 10 FT WIDE.

ALL DIMENSIONS ARE IN INCHES (MILLIMETERS) UNLESS OTHERWISE SHOWN.

FILE NAME =	USER NAME = midyja	DESIGNED - D.W.S.	REVISED - S.P.B. 01-07
pw:\plenroom.dot.illinois.gov\PIDOT\Documents\IDOT Offices\District 1\Projects\0134318\Drawings\Design\0134318-sht-plen.dgn		CHECKED -	REVISED - S.P.B. 12-09
Default	PLOT SCALE = 100.0000' / in.	DATE - 02-83	REVISED - M.D. 06-13
	PLOT DATE = 5/13/2021		REVISED - M.D. 01-18

**STATE OF ILLINOIS
DEPARTMENT OF TRANSPORTATION**

**ENTRANCE AND EXIT RAMP
CLOSURE DETAILS**

SCALE: NONE SHEET 1 OF 1 SHEETS STA. TO STA.

F.A. RTÉ.	SECTION	COUNTY	TOTAL SHEETS	SHEET NO.
VAR.	2021-091-CBL	VARIOUS	13	9
TC-08		CONTRACT NO.	62P21	
ILLINOIS FED. AID PROJECT				

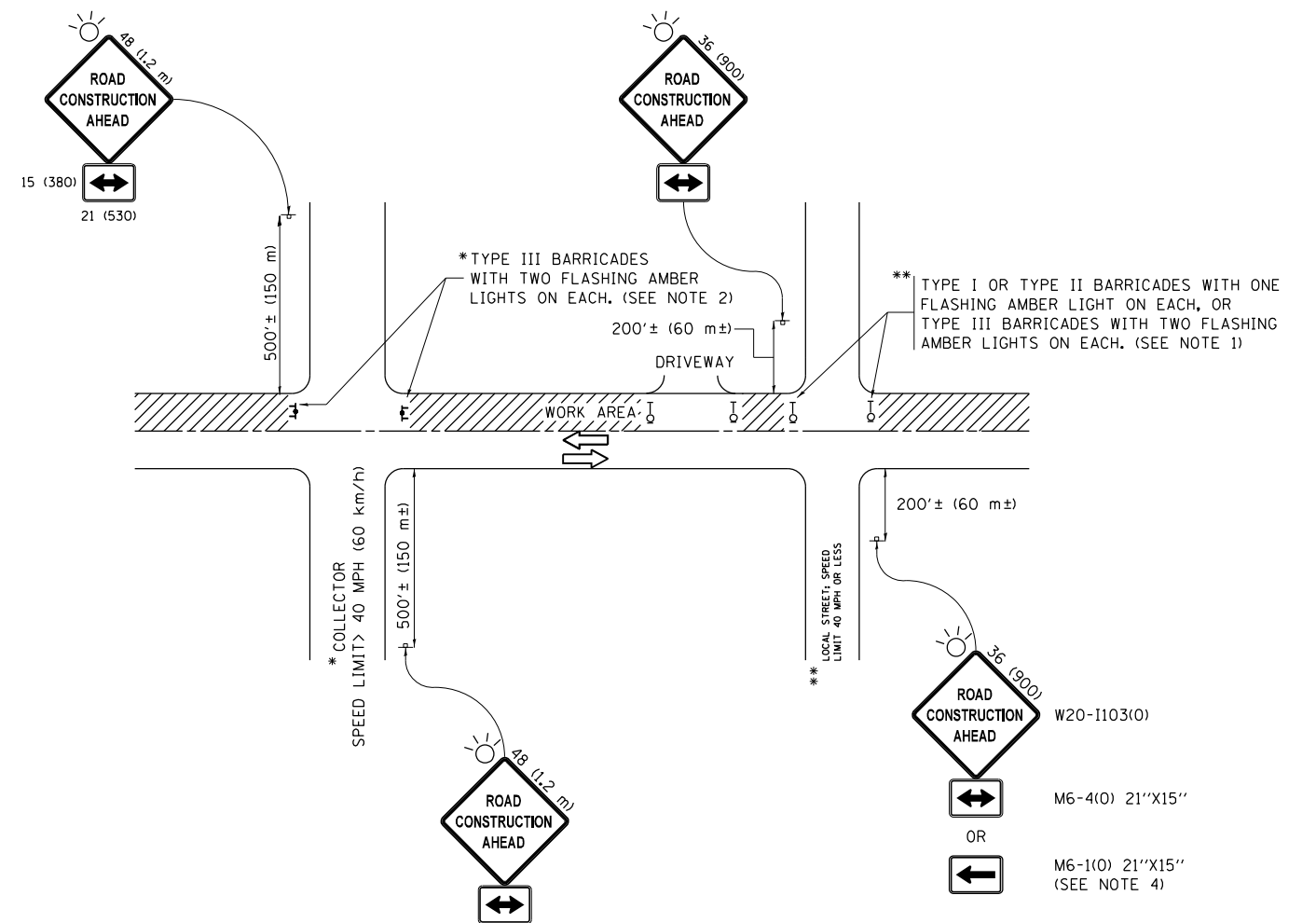

NOTES:

1. SIDE ROAD WITH A SPEED LIMIT OF 40 MPH (60 km/h) OR LESS AS SHOWN ON THE DRAWING AND AS DIRECTED BY THE ENGINEER:
 - a) ONE "ROAD CONSTRUCTION AHEAD" SIGN 36 x 36 (900x900) WITH A FLASHER MOUNTED ON IT APPROXIMATELY 200' (60 m) IN ADVANCE OF THE MAIN ROUTE.
 - b) THE CLOSED PORTION OF THE MAIN ROUTE SHALL BE PROTECTED BY BLOCKING WITH TYPE I, TYPE II OR TYPE III BARRICADES, 1/3 OF THE CROSS SECTION OF THE CLOSED PORTION.
2. SIDE ROAD WITH A SPEED LIMIT GREATER THAN 40 MPH (60 km/h) AS SHOWN ON THE DRAWING AND AS DIRECTED BY THE ENGINEER:
 - a) ONE "ROAD CONSTRUCTION AHEAD" SIGN 48 x 48 (1.2 m x 1.2 m) WITH A FLASHER MOUNTED ON IT APPROXIMATELY 500' (150 m) IN ADVANCE OF THE MAIN ROUTE.
 - b) THE CLOSED PORTION OF THE MAIN ROUTE SHALL BE PROTECTED BY BLOCKING WITH TYPE III BARRICADES, 1/2 OF THE CROSS SECTION OF THE CLOSED PORTION.
3. CONES MAY BE SUBSTITUTED FOR BARRICADES OR DRUMS AT HALF THE SPACING DURING DAY OPERATIONS. CONES SHALL BE A MINIMUM OF 28 (710) IN HEIGHT.
4. WHEN THE SIDE ROAD LIES BETWEEN THE BEGINNING OF THE MAINLINE SIGNING AND THE WORK ZONE, A SINGLE HEADED ARROW (M6-1) SHALL BE USED IN LIEU OF THE DOUBLE HEADED ARROW (M6-4).
5. WHEN WORK IS BEING PERFORMED ON A SIDE ROAD OR DRIVEWAY, FOLLOW THE APPLICABLE STANDARD(S). THE DIRECTIONAL ARROW (M6-1 OR M6-4) SHALL BE COVERED OR REMOVED WHEN NO LONGER CONSISTENT WITH THE TRAFFIC CONTROL SET-UP.
6. ADVANCE WARNING SIGNS ARE TO BE OMITTED ON DRIVEWAYS UNLESS OTHERWISE SPECIFIED IN THE PLANS OR BY THE ENGINEER.
7. THE TRAFFIC CONTROL AND PROTECTION FOR SIDE ROADS, INTERSECTIONS, AND DRIVEWAYS SHALL BE INCLUDED IN THE COST OF SPECIFIED TRAFFIC CONTROL STANDARDS OR ITEMS.

All dimensions are in inches (millimeters) unless otherwise shown.

FILE NAME =	USER NAME = midyja	DESIGNED - L.H.A.	REVISED - A. HOUSEH 10-15-96
p:\plnroom.dot\illinois.gov\PIDOT\Documents\IDOT Offices\District 1\Projects\0134318\DRAWING\Design\0134318-sht-pln.dgn		CHECKED -	REVISED - T. RAMMACHER 01-06-00
Default	PLOT SCALE = 100.0000' / in.	DATE - 06-89	REVISED - A. SCHUETZE 07-01-13
	PLOT DATE = 5/13/2021		REVISED - A. SCHUETZE 09-15-16

**STATE OF ILLINOIS
DEPARTMENT OF TRANSPORTATION**

**TRAFFIC CONTROL AND PROTECTION FOR
SIDE ROADS, INTERSECTIONS, AND DRIVEWAYS**

SCALE: NONE SHEET 1 OF 1 SHEETS STA. TO STA.

F.A. RTE.	SECTION	COUNTY	TOTAL SHEETS	SHEET NO.
VAR.	2021-091-CBL	VARIOUS	13	10
TC-10		CONTRACT NO.	62P21	
ILLINOIS FED. AID PROJECT				

TURN BAY ENTRANCE AT START OF LANE CLOSURE TAPER

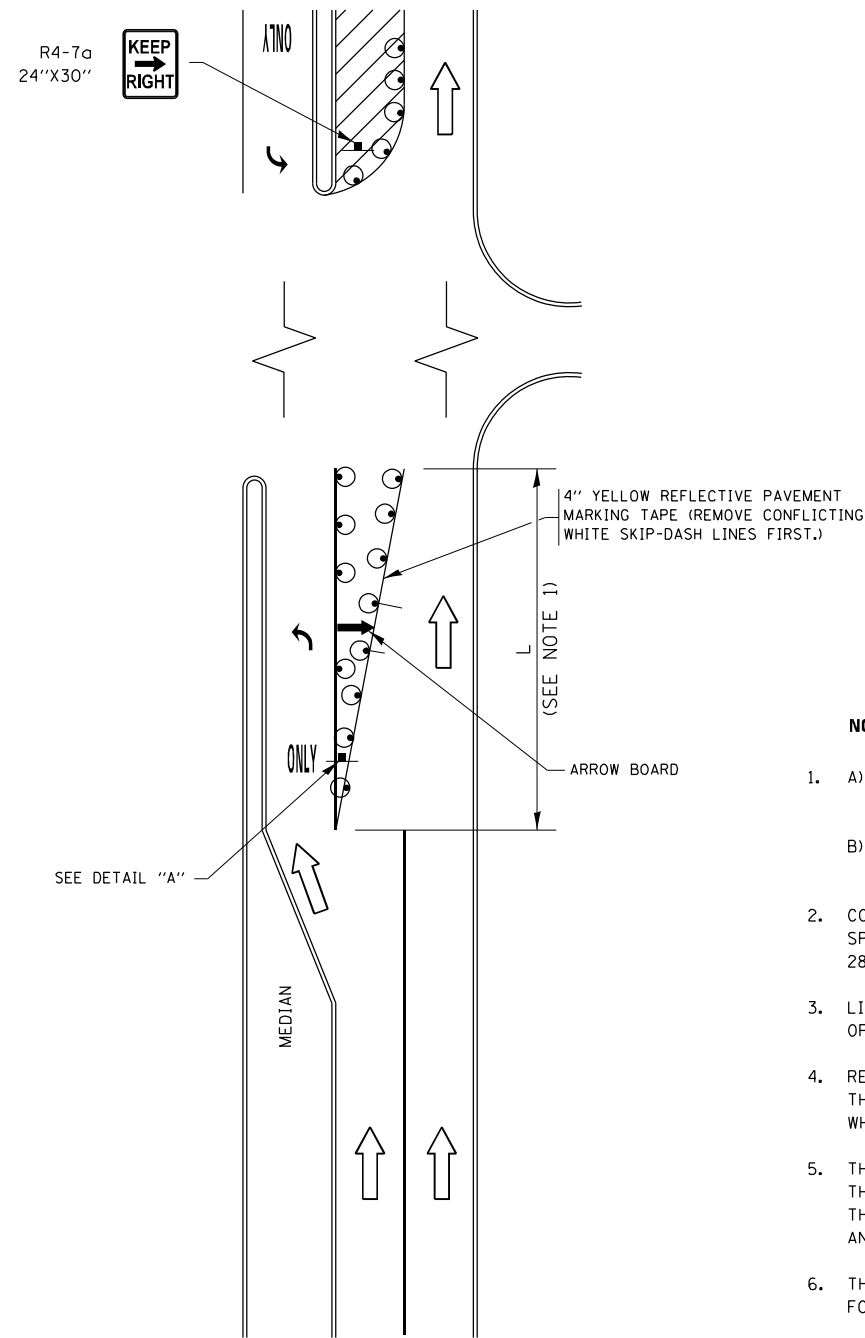

FIGURE 1

TURN BAY ENTRANCE WITHIN A LANE CLOSURE

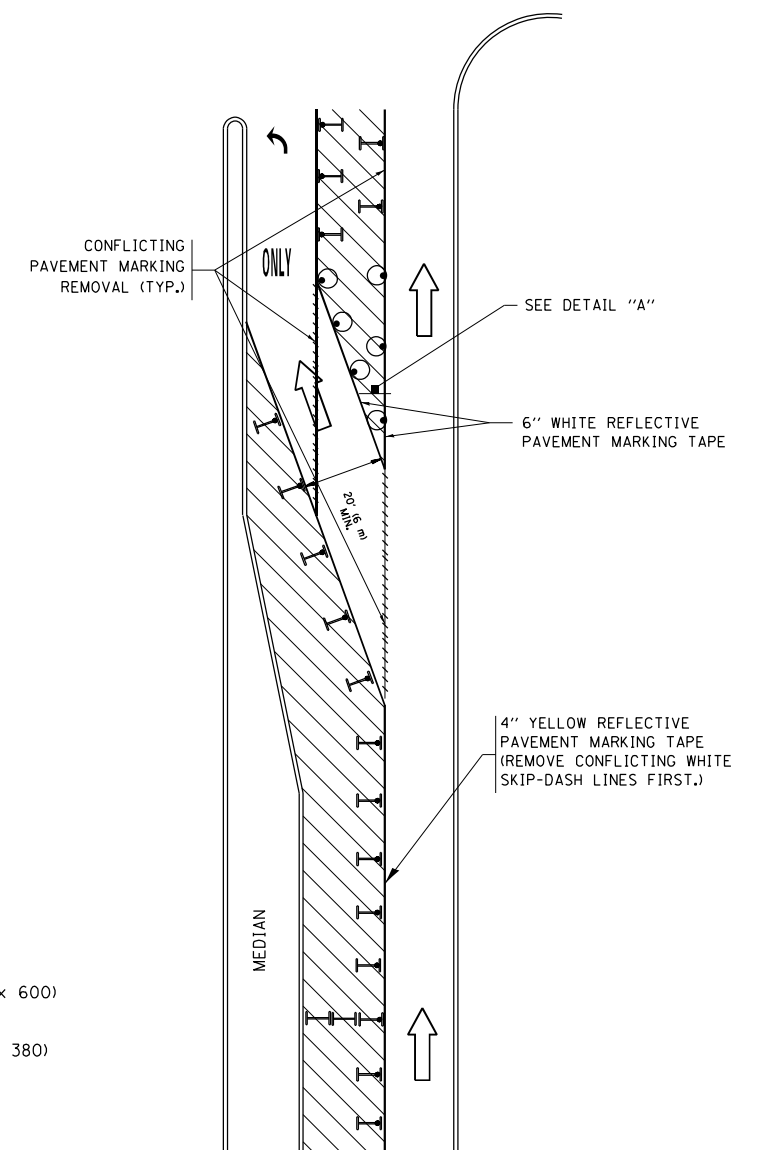
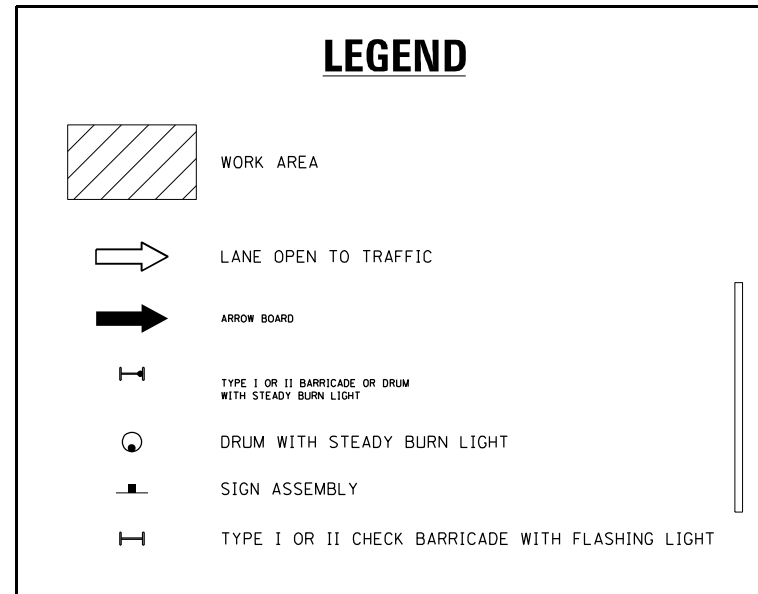
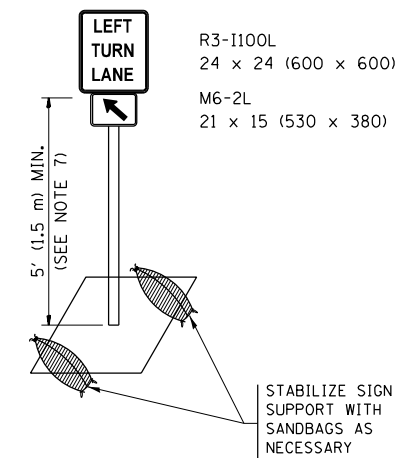

FIGURE 2



NOTES:

1. A) WHEN "L" IS \leq THE STORAGE LENGTH OF THE TURN LANE (AS SHOWN IN FIG. 1), USE FIGURE 1.
B) WHEN "L" IS $>$ THE STORAGE LENGTH OF THE TURN LANE OR THE TURN LANE IS WITHIN THE LANE CLOSURE, USE FIGURE 2.
2. CONES MAY BE SUBSTITUTED FOR BARRICADES OR DRUMS AT HALF THE SPACING DURING DAY OPERATIONS. CONES SHALL BE A MINIMUM OF 28 (710) IN HEIGHT.
3. LIGHTS WILL NOT BE REQUIRED ON BARRICADES OR DRUMS FOR DAY OPERATIONS. ALL LIGHTS SHALL BE MONODIRECTIONAL.
4. REFLECTIVE TEMPORARY PAVEMENT MARKINGS SHALL BE PLACED THROUGHOUT THE BARRICADED AREAS OF EACH TURN BAY AS SHOWN WHERE THE CLOSURE TIME IS GREATER THAN FOURTEEN (14) DAYS.
5. THIS APPLICATION ALSO APPLIES WHEN WORK IS BEING PERFORMED IN THE RIGHT LANE(S) AND THE RIGHT TURN BAY IS TO REMAIN OPEN. UNDER THIS CONDITION, "RIGHT TURN LANE" R3-1100R 24 x 24 (600 x 600) AND M6-2R 21 x 15 (530 x 380) SHALL BE USED.
6. THESE CONTROLS SHALL SUPPLEMENT MAINLINE TRAFFIC CONTROL FOR LANE CLOSURES.
7. THE SIGNS SHALL BE MOUNTED ABOVE THE BARRICADES/DRUMS ON SEPARATE SIGN SUPPORTS THAT MEET NCHRP 350 OR MASH PREQUIREMENTS.
8. TRAFFIC CONTROL AND PROTECTION AT TURN BAYS (TO REMAIN OPEN TO TRAFFIC) SHALL BE INCLUDED IN THE COST OF SPECIFIED TRAFFIC CONTROL STANDARDS OR ITEMS.



DETAIL A

All dimensions are in inches (millimeters) unless otherwise shown.

FILE NAME =	USER NAME = midyja	REVISED - T. RAMMACHER 09-08-94	REVISED - R. BORO 09-14-09	STATE OF ILLINOIS DEPARTMENT OF TRANSPORTATION	TRAFFIC CONTROL AND PROTECTION AT TURN BAYS (TO REMAIN OPEN TO TRAFFIC)			F.A. RTE.	SECTION	COUNTY	TOTAL SHEETS	SHEET NO.
pw:\planroom.dot.illinois.gov\PIDOT\Documents\IDOT Offices\District 1\Projects\0134318\REVISED Design\0134318-01-07-95	REVISED - A. HOUSEH 11-07-95	REVISED - A. SCHUETZE 07-01-13	REVISED - A. SCHUETZE 09-15-16					VAR.	2021-091-CBL	VARIOUS	13	11
Default	PLOT SCALE = 100.0000' / in.	REVISED - A. HOUSEH 10-12-96	REVISED -		TC-14			CONTRACT NO. 62P21				
	PLOT DATE = 5/13/2021	REVISED - T. RAMMACHER 01-06-00	REVISED -		SCALE: NONE	SHEET 1	OF 1 SHEETS	STA.	TO STA.	ILLINOIS FED. AID PROJECT		

PARTIAL RAMP CLOSURE DETAILS

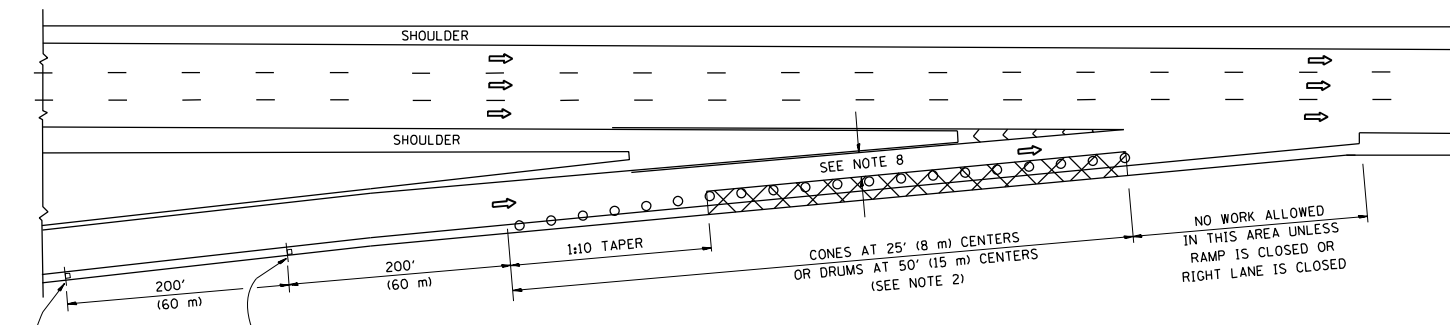

TYPICAL ENTRANCE RAMP

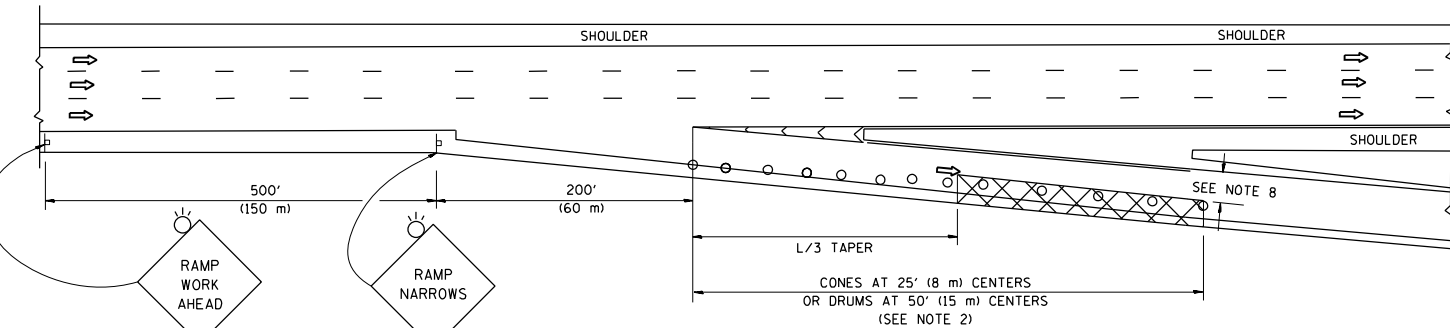

TYPICAL EXIT RAMP

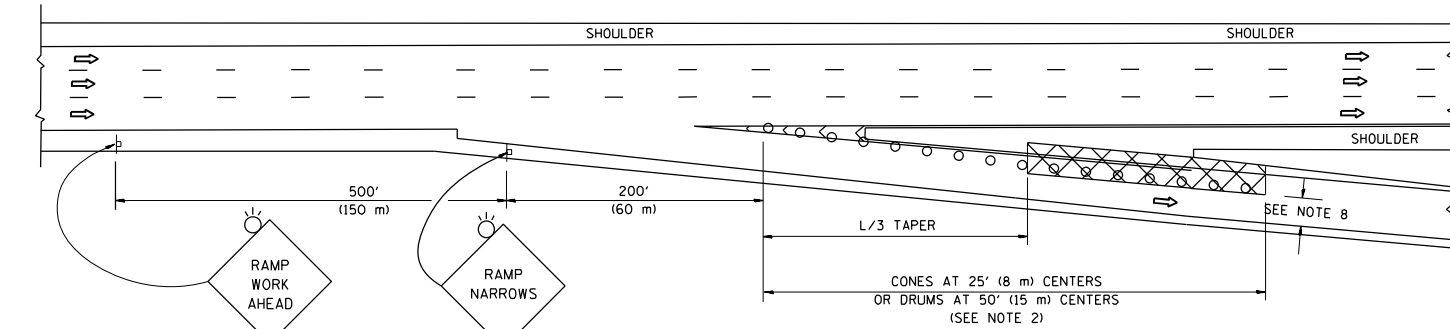

TYPICAL EXIT RAMP

SYMBOLS

- ACTIVE WORK AREA
- SIGN ON PORTABLE OR PERMANENT SUPPORT
- FLAGGER WITH CONTROL SIGN
- TYPE II BARRICADE OR DRUM
- CONE, DRUM OR BARRICADE
- IMPACT ATTENUATOR OF TYPE AND TEST LEVEL SPECIFIED

GENERAL NOTES

1. THE "L" DISTANCE EQUALS:

SPEED LIMIT	FORMULAS
45 mph (80 km/h)	METRIC ENGLISH
OR GREATER:	$L=0.65(W)(S)$ $L=(W)(S)$

W = WIDTH OF OFFSET IN FEET (METERS)
 S = NORMAL POSTED SPEED MPH (KM/H)
2. TYPE II BARRICADES OR DRUMS ARE REQUIRED FOR ALL NIGHTTIME CLOSURES. TYPE II BARRICADES OR DRUMS WITH MONODIRECTIONAL STEADY BURN LIGHTS ARE REQUIRED FOR DELINEATING OBSTACLES, EXCAVATIONS, OR HAZARDS EXCEEDING 100 FT (30m) IN LENGTH AT NIGHT.
3. ALL SIGNS SHALL BE POST MOUNTED IF THE CLOSURE TIME EXCEEDS FOUR DAYS.
4. FLASHING LIGHTS SHALL BE USED DURING THE HOURS OF DARKNESS AND SHALL BE INSTALLED ABOVE THE FIRST TWO SETS OF SIGNS.
5. THE IMPACT ATTENUATOR, TEMPORARY IS NOT REQUIRED WHEN THE TEMPORARY CONCRETE BARRIER WALL IS PROTECTED BY OR IS TIED INTO THE EXISTING GUARDRAIL. IF OFFSET IS LESS THAN 5 FEET USE NARROW USE TYPE DEVICE TO MEET NCHRP350/MASH.
6. AUTHORIZATION FROM THE DISTRICT'S BUREAU OF TRAFFIC IS REQUIRED FOR ALL FREEWAY CLOSURES.
7. THE FLAGGER AND FLAGGER SIGN ARE REQUIRED AT THE ABOVE WORK SITES WHEN:
 - a. FOUR OR MORE WORK VEHICLES ENTER THE TRAFFIC LANES IN A ONE HOUR PERIOD.
 - b. THE WORK ACTIVITY REQUIRES FREQUENT ENCROACHMENT INTO THE LANE OPEN TO TRAFFIC.
 THE FLAGGER SHALL BE STATIONED APPROXIMATELY 100' (30 m) TO 200' (60 m) IN ADVANCE OF THE WORKERS.
8. 12' MIN. WIDTH TANGENT SECTION
 16' MIN. WIDTH CURVE SECTION.

SHOULDER CLOSURE DETAILS

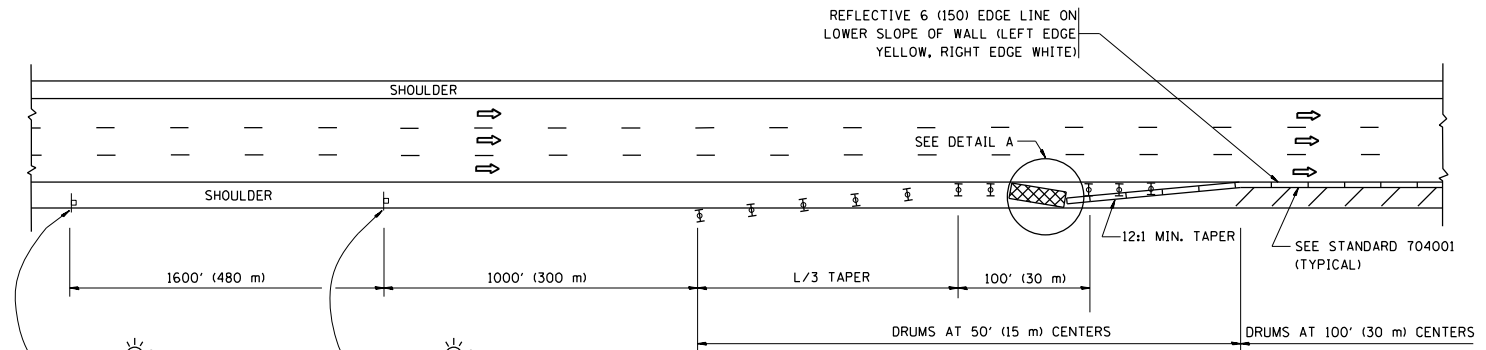

PERMANENT SHOULDER CLOSURE

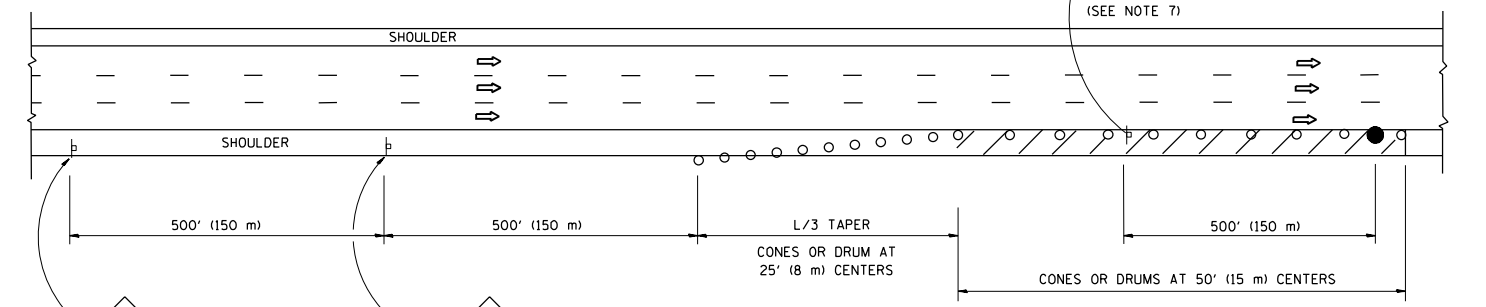

DAYTIME SHOULDER CLOSURE

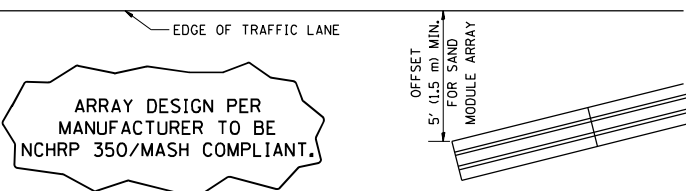

ARRAY DESIGN PER MANUFACTURER TO BE NCHRP 350/MASH COMPLIANT.

DETAIL "A"
IMPACT ATTENUATOR, TEMPORARY
(SEE NOTE 5)

ALL DIMENSIONS ARE IN INCHES (MILLIMETERS) UNLESS OTHERWISE SHOWN.

FILE NAME =	USER NAME = midyja	DESIGNED -	REVISED - S.P.B. 01-07
pw:\planning\dot.illinois.gov\PIWOT\Documents\IDOT Offices\District 1\Projects\0134318\Drawings\Design\DWG\Sheet-plen.dgn		DRAWN -	REVISED - S.P.B. 12-09
Default	PLOT SCALE = 100.0000' / in.	CHECKED -	REVISED - M.D. 06-13
	PLOT DATE = 5/13/2021	DATE -	REVISED - M.D. 01-18

STATE OF ILLINOIS
DEPARTMENT OF TRANSPORTATION

TRAFFIC CONTROL DETAILS FOR FREEWAY
SHOULDER CLOSURES AND PARTIAL RAMP CLOSURES

SCALE: NONE SHEET 1 OF 1 SHEETS STA. TO STA.

F.A. RTE.	SECTION	COUNTY	TOTAL SHEETS	SHEET NO.
VAR.	2021-091-CBL	VARIOUS	13	12
TC-17		CONTRACT NO.	62P21	
ILLINOIS FED. AID PROJECT				

SIGNING FOR FLAGGING OPERATIONS AT WORK ZONE OPENINGS

WORK ZONE EXIT OPENING

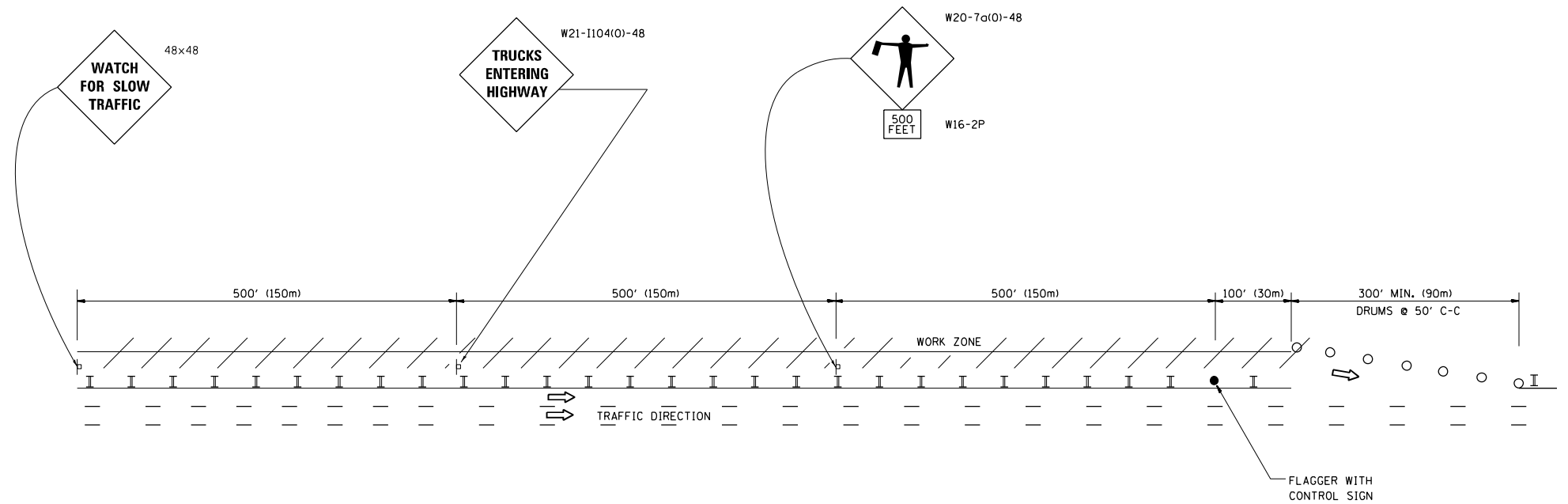

WORK ZONE ENTRY OPENING

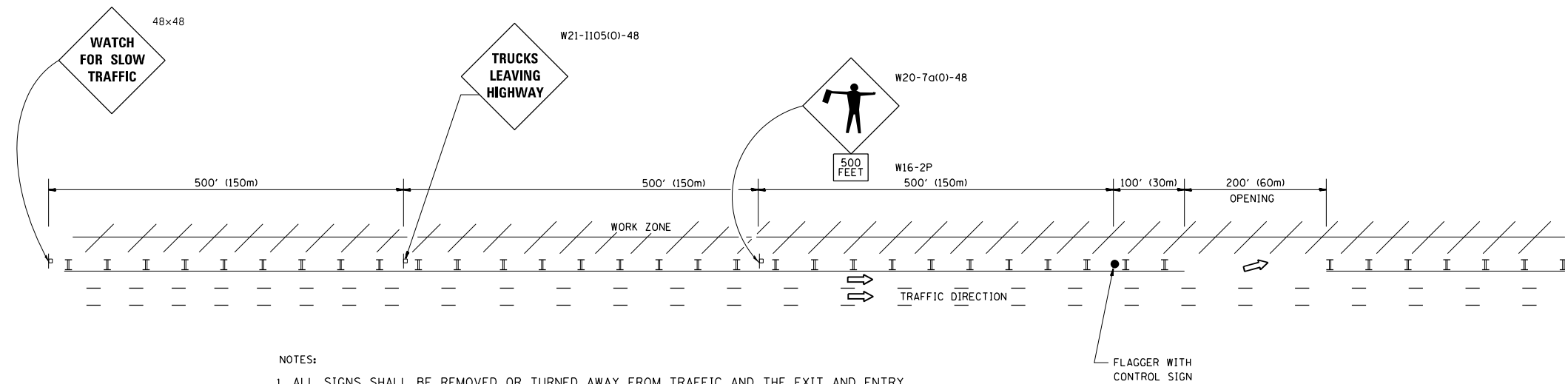

NOTES:

1. ALL SIGNS SHALL BE REMOVED OR TURNED AWAY FROM TRAFFIC AND THE EXIT AND ENTRY OPENINGS SHALL BE CLOSED WHEN THE FLAGGING OPERATION CEASES. NON OPERATING EQUIPMENT SHALL COMPLY WITH ARTICLE 701.11
2. WORK ZONE OPENINGS SHALL BE A MINIMUM OF ONE HALF MILE APART AND A MINIMUM OF ONE QUARTER MILE FROM ALL ENTRANCE AND EXIT RAMP.
3. EXITING THE WORK ZONE AT ANY PLACE OTHER THAN AT A WORK ZONE EXIT OPENING WILL BE PROHIBITED.
4. ALL VEHICLES SHALL ENTER THE WORK ZONE AT ENTRY OPENINGS, USING THEIR TURN SIGNALS TO WARN MOTORISTS
5. FLAGGERS SHALL NOT STOP TRAFFIC OR DIRECT TRAFFIC INTO AN ADJACENT LANE.

ALL DIMENSIONS ARE IN INCHES (MILLIMETERS) UNLESS OTHERWISE SHOWN

FILE NAME =	USER NAME = midyja	DESIGNED -	REVISED - J.A.F. 02-06	STATE OF ILLINOIS DEPARTMENT OF TRANSPORTATION	FREEWAY/EXPRESSWAY SIGNING FOR FLAGGING OPERATIONS AT WORK ZONE OPENINGS ON FREEWAYS/EXPRESSWAYS	F.A. RTE.	SECTION	COUNTY	TOTAL SHEETS	SHEET NO.
pw:\plenroom.dot.illinois.gov\PIDOT\Documents\IDOT Offices\District 1\Projects\0134318\DRAWING\Design\0134318-sht-plen.dgn		DRAWN	REVISED - S.P.B. 01-07			VAR.	2021-091-CBL	VARIOUS	13	13
	PLOT SCALE = 100.0000' / in.	CHECKED -	REVISED - S.P.B. 12-09			TC-18		CONTRACT NO. 62P21		
	PLOT DATE = 5/13/2021	DATE -	REVISED - M.D. 06-13			SCALE: NONE		SHEET NO. 1 OF 1 SHEETS		STA. TO STA.
						FED. ROAD DIST. NO. 1 ILLINOIS FED. AID PROJECT				