

SECTION A-A

BEAM NO'S. 1 THRU 10

EXIST. EXP. BRG. AT SO. ABUT.

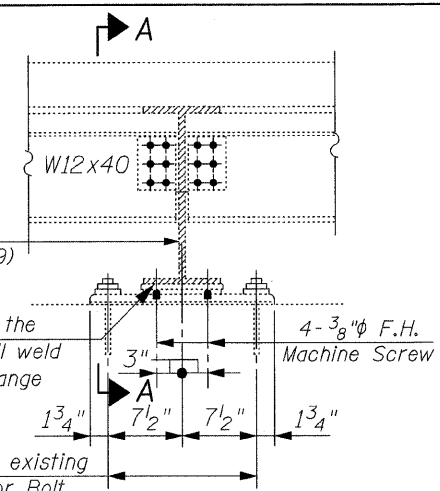

EXISTING ELEVATION

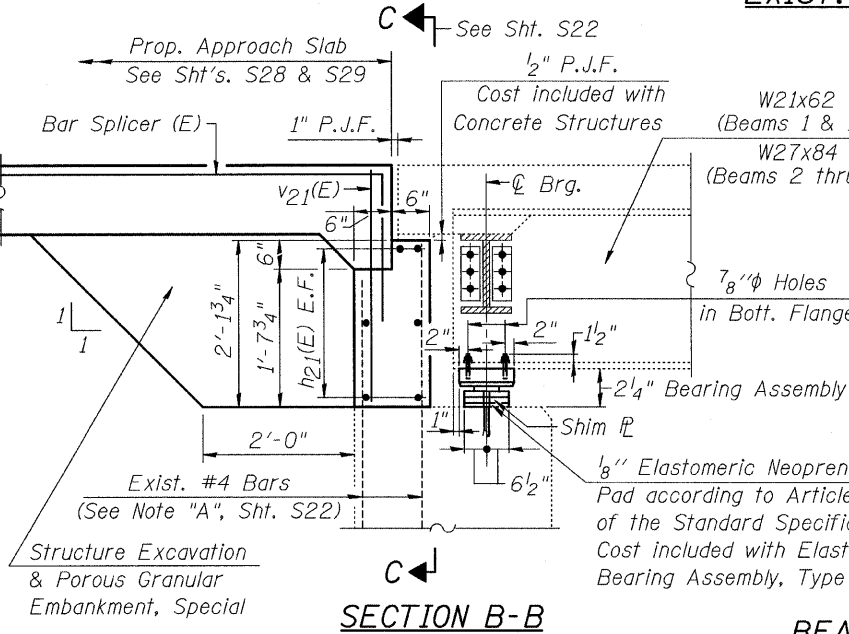

SECTION B-B

BEAM NO'S. 1 THRU 10

PROP. TYPE II ELASTOMERIC EXP. BRG. AT SO. ABUT.

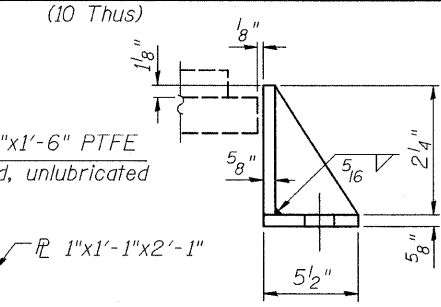

SIDE RETAINER

Equivalent rolled angle with stiffeners will be allowed in lieu of welded plates.

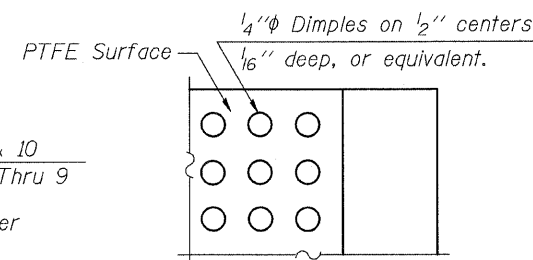

PLAN-PTFE SURFACE

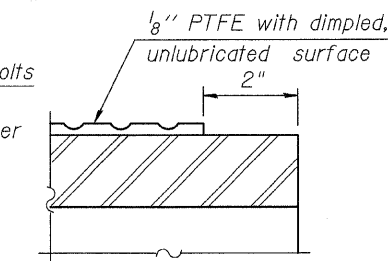

SECTION THRU PTFE

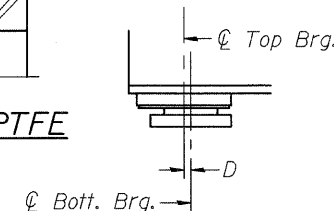

ABOVE 50°F.
(Move bott. brg. toward fixed brg.)

BELOW 50°F.
(Move bott. brg. away from fixed brg.)

SETTING ANCHOR BOLTS AT EXP. BRG.

D = 1/8" per each 100' of expansion for every 15° temp. change from the normal temp. of 50°F.

BEARING REPLACEMENT NOTES:

The Contractor shall submit Plans for Jacking the existing Superstructure for approval by the Engineer prior to commencing any work with the Bearings. The submittal shall be prepared and sealed by a Licensed Structural Engineer in Illinois.

It shall be the Contractor's responsibility to verify all dimensions between the bottom of the Bridge Beams and the Top of the Bearing Seat in the field prior to Construction or ordering of materials.

Jacking and Removing of existing Bearings shall be done after the existing Overlay Removal is completed but before the new Overlay is poured.

The Contractor shall supply additional Shim Plates if required to bring devices to Grade. Cost included with Elastomeric Bearing Assembly, Type II.

Drilled and set Anchor Bolts shall be installed according to Article 521.06 of the Standard Specifications. Anchor Bolts shall be ASTM F1554 all-thread (or an Engineer-approved alternate material) of the grade and diameter specified. ASTM A307 Grade C Anchor Bolts may be used in lieu of ASTM F1554 Grade 36 (Fy-36ksi). The corresponding specified grade of AASHTO M314 Anchor Bolts may be used in lieu of ASTM F1554.

Anchor Bolts for Type II Bearings shall be placed in holes drilled through the bottom Bearing Plate after members are in place. Side Retainers shall be placed after bolts are installed.

Side Retainers and other Steel Members required for the Bearing Assembly shall be included in the cost of Elastomeric Bearing Assembly, Type II.

The 1/8" PTFE Sheet shall be bonded directly to the bottom Steel Plate with a two-component, Medium Viscosity Epoxy Resin, conforming to the requirements of the Federal Specification MMM-A-134, Type I. The bond agent shall be applied on the full area of contact surfaces.

Bonding of 1/8" PTFE Sheet during Vulcanizing Process will be permitted providing the process and method of adjusting Assembly height is approved by the Engineer.

The new Bearings shall be in place and the Jacks shall be lowered before the new Overlay is poured.

BEAM REACTION TABLE

	Beam No.'s. 1 & 10	Beam No.'s. 2 Thru 9 (Span 1)
R ₀	(k) 40.2	16
R _L	(k) 15.4	39
R _{RM}	(k) -	12
R _{Total}	(k) 55.6	67

Minimum jack capacity at each bearing for Beam No.'s. 1 & 10 = 80k
Minimum jack capacity at each bearing for Beam No.'s. 2 thru 9 = 32k

BILL OF MATERIAL

Item	Unit	Total
Jack and Remove Existing Bearings	Each	10
Elastomeric Bearing Assembly, Type II	Each	10
Anchor Bolts, 1"φ	Each	20

NOTE:
For additional Bill of Material, see Sht. S22

FILE NAME = bearing-exp-so.abut.dgn
PLOT DATE = 7/8/2009

CHRISTIAN-ROGE & ASSOCIATES, INC.
ENGINEERS-PLANNERS-SURVEYORS
211 WEST WACKER DRIVE
CHICAGO, ILLINOIS 60606
PHONE: (312)372-2023 FAX: (312)372-5274

DESIGNED - B.N.S./J.C.N. REVISIONS -
DRAWN - D.L./R.E.S./F.M. REVISIONS -
CHECKED - B.N.S./J.C.N. REVISIONS -
DATE - JULY 8, 2009 REVISIONS -

STATE OF ILLINOIS
DEPARTMENT OF TRANSPORTATION

EXPANSION BEARINGS - SOUTH ABUTMENT
AT BEAM NO'S. 1 THRU 10
KEDZIE AVENUE OVER CAL-SAG CHANNEL S.N. 016-0762

F.A.U. RTE.	SECTION	COUNTY	TOTAL SHEETS	SHEET NO.
2831	1313, 1-1-2	COOK	41	27

CONTRACT NO. 60D75
FED. ROAD DIST. NO. 1 | ILLINOIS | FED. AID PROJECT