

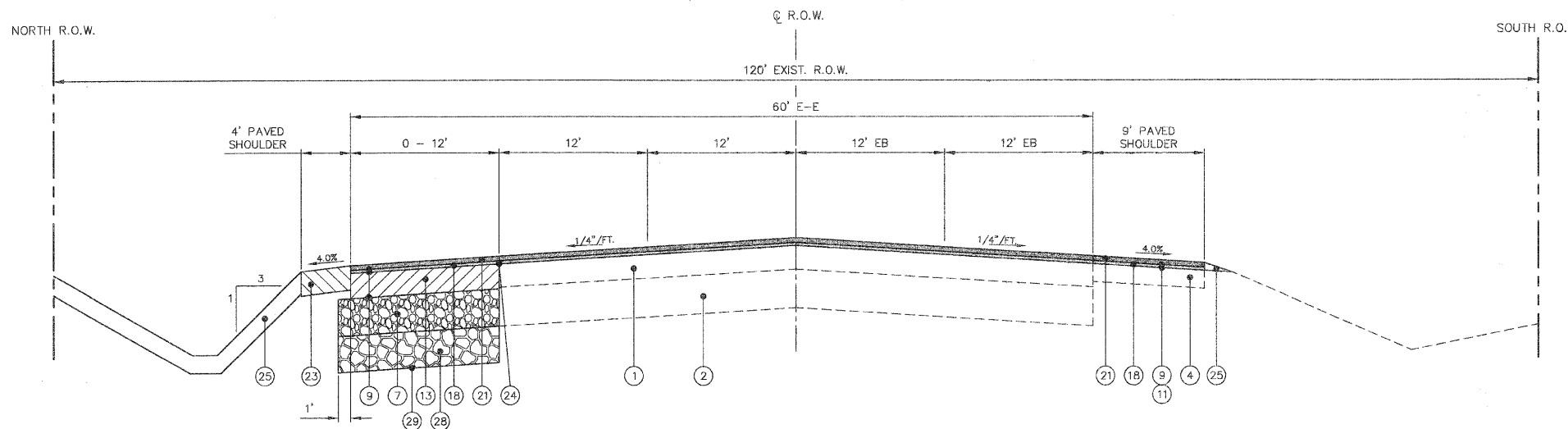

F.A.U. RTE.	SECTION	COUNTY	TOTAL SHEETS	SHEET NO.
1680	05-00038-00-PV	KANE/KENDALL	130	10
STA.		TO STA.		
FED. ROAD DIST. NO. -		ILLINOIS	FED. AID PROJECT	

**PROPOSED PAVEMENT CROSS SECTION
CATERPILLAR DRIVE
(STA. 3002+20 TO STA. 3005+50)**



**PROPOSED PAVEMENT CROSS SECTION
CATERPILLAR DRIVE
(STA. 3005+50 TO STA. 3010+06)**

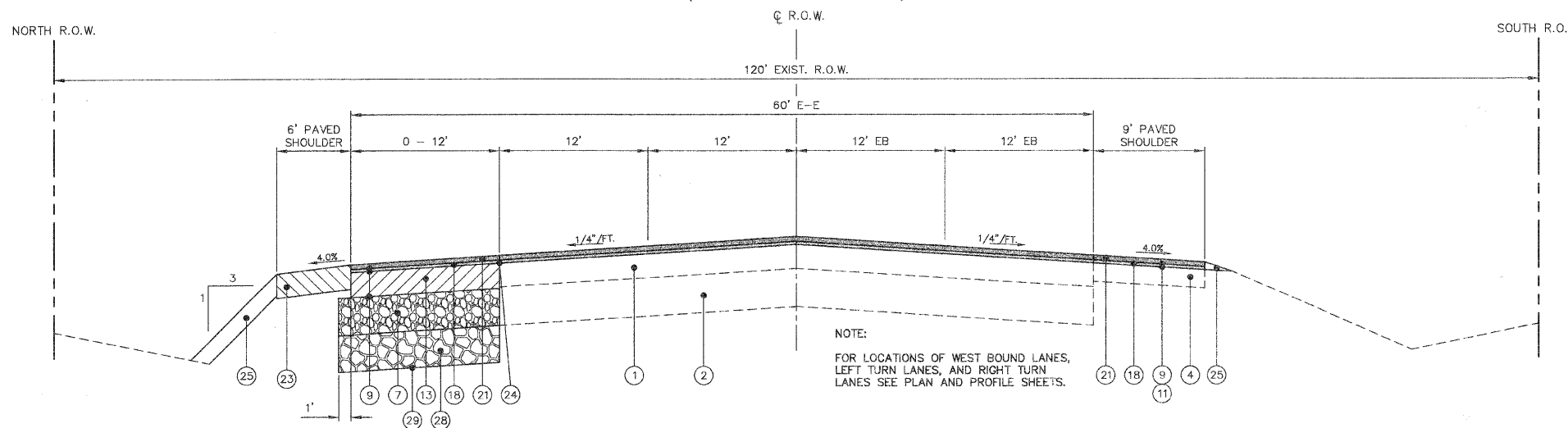

- LEGEND**
- ① EXISTING ASPHALT PAVEMENT
 - ② EXISTING BASE MATERIAL
 - ③ EXISTING AGGREGATE SHOULDER
 - ④ EXISTING PAVED SHOULDER
 - ⑤ PAVEMENT REMOVAL
 - ⑥ EARTH EXCAVATION (WIDENING)
 - ⑦ PROPOSED AGGREGATE SUBGRADE, 12"
 - ⑧ PROPOSED COMBINATION CONCRETE CURB AND GUTTER, TYPE B-6.12
 - ⑨ BITUMINOUS MATERIALS (PRIME COAT)
 - ⑩ POLYMERIZED BITUMINOUS MATERIALS (PRIME COAT)
 - ⑪ AGGREGATE (PRIME COAT)
 - ⑫ PROPOSED HOT-MIX ASPHALT BASE COURSE, 6 3/4" (2 LIFTS)
 - ⑬ PROPOSED HOT-MIX ASPHALT BASE COURSE, 7 1/2" (3 LIFTS)
 - ⑭ PROPOSED POLYMERIZED HOT-MIX ASPHALT BINDER COURSE, IL-19.0, N90, 12" (3 LIFTS)
 - ⑮ PROPOSED POLYMERIZED HOT-MIX ASPHALT BASE COURSE, IL-19.0, N90, 13" (3 LIFTS)
 - ⑯ PROPOSED HOT-MIX ASPHALT BINDER COURSE, IL-19.0, N50, 2.25"
 - ⑰ PROPOSED HOT-MIX ASPHALT BINDER COURSE, IL-19.0, N50, 8" (3 LIFTS)
 - ⑱ PROPOSED LEVELING BINDER (MACHINE METHOD), N70, 1.0" & VARIES
 - ⑲ PROPOSED HOT-MIX ASPHALT SURFACE COURSE, MIX "D", N50, 2"
 - ⑳ PROPOSED HOT-MIX ASPHALT SURFACE COURSE, MIX "D", N70, 1.5"
 - ㉑ PROPOSED HOT-MIX ASPHALT SURFACE COURSE, MIX "D", N70, 2"
 - ㉒ PROPOSED POLYMERIZED HOT-MIX ASPHALT SURFACE COURSE, MIX "F", N90, 2"
 - ㉓ PROPOSED HOT-MIX ASPHALT SHOULDERS, 8" (2" SURFACE, 6" BINDER)
 - ㉔ STRIP REFLECTIVE CRACK CONTROL
 - ㉕ TOPSOIL, SEEDING, FERTILIZER AND MULCH PER PLANS
 - ㉖ HOT-MIX ASPHALT SURFACE REMOVAL, 1.5"
 - ㉗ HOT-MIX ASPHALT SURFACE REMOVAL, 2"
 - ㉘ POROUS GRANULAR EMBANKMENT SUBGRADE, AS NEEDED
 - ㉙ GEOTECHNICAL FABRIC FOR GROUND STABILIZATION, AS NEEDED

HOT-MIX ASPHALT MIXTURE REQUIREMENT TABLE

ROADWAY	OPERATION	PAY ITEM DESCRIPTION	AC TYPE	VOIDS
CATERPILLAR DRIVE (STA 3002+20 TO STA 3010+06)	WIDENING, 7 1/2"	HOT-MIX ASPHALT BASE COURSE, 7 1/2" (HMA BINDER IL-19.0 MM)	PG 64-22"	4% @ 70 Gyr.
CATERPILLAR DRIVE (STA 3002+20 TO STA 3010+06)	OVERLAY, 3"	LEVELING BINDER (MACHINE METHOD), N70, 1" & VARIES (3/4" MIN.) (IL-9.5 MM)	PG 64-22"	4% @ 70 Gyr.
CATERPILLAR DRIVE (STA 3002+20 TO STA 3010+06)	HMA SHOULDER	HOT-MIX ASPHALT SURFACE COURSE, MIX "D", N70, 2" (IL-9.5 MM)	PG 64-22"	4% @ 70 Gyr.
CATERPILLAR DRIVE	HMA SHOULDER	HOT-MIX ASPHALT SHOULDER, 8" (HMA BINDER IL-19.0 MM) (BOTTOM 6")	PG 64-22"	4% @ 50 Gyr.
CATERPILLAR DRIVE	HMA SHOULDER	(HMA SURFACE, MIX "D", IL-9.5 MM) (TOP 2")	PG 64-22"	4% @ 50 Gyr.
CATERPILLAR DRIVE	PATCHING	CLASS D PATCHES (HMA BINDER IL-19.0 MM)	PG 64-22"	4% @ 70 Gyr.

* WHEN RAP EXCEEDS 20%, THE NEW ASPHALT BINDER IN THE MIX SHALL BE PG 58-22.
THE UNIT WEIGHT USED TO CALCULATE ALL HOT-MIX ASPHALT QUANTITIES IS 112 LBS/SQ YD./INCH.

REVISIONS		ILLINOIS DEPARTMENT OF TRANSPORTATION	
NAME	DATE	<h1>TYPICAL CROSS SECTIONS</h1>	
SCALE:		DRAWN BY: KKP	
DATE: 03-26-09		CHECKED BY: TWV	

DATE	
BY	
PLAN	
DATE	
BY	
PLotted	
Checked	
By	
Way	
Checked	
By	
File	
Name	
NO.	

DATE	
BY	
PROFILE	
DATE	
BY	
Plotted	
Checked	
By	
Way	
Checked	
By	
File	
Name	
NO.	