

A Section - Stairs

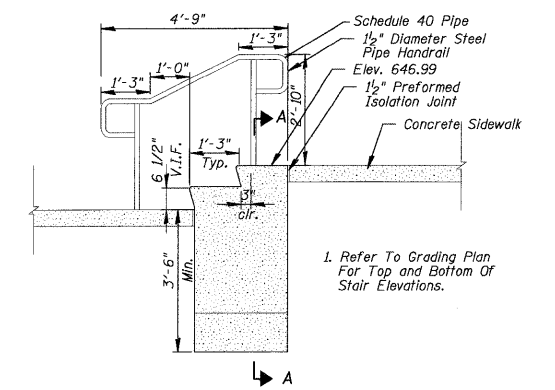

A Section - Stairs

GENERAL NOTES:

DRIVEWAY SLOPES, LOCATIONS, & GEOMETRIC LAYOUT SHALL BE IN ACCORDANCE WITH THE LATEST EDITION OF THE "HANDBOOK FOR POLICY ON PERMITS FOR ACCESS DRIVEWAYS TO STATE HIGHWAYS". FOR FURTHER LAYOUT REQUIREMENTS, REFER TO ILLUSTRATIONS IN THE PERMIT HANDBOOK. DRIVEWAYS SHALL BE REPLACED IN KIND, UNLESS OTHERWISE NOTED ON THE PLANS.

COMMERCIAL DRIVEWAYS SHALL BE CONSTRUCTED WITH CONCRETE CURB, TYPE B RETURNS EXCEPT WHEN THE SIDEWALK EDGE IS 4 FEET (1.2 METERS) OR LESS FROM THE BACK OF CURB, CONSTRUCT A FLARE DRIVEWAY WITHOUT CURB.

THE RESIDENT ENGINEER SHALL CONTACT THE TRAFFIC PERMIT OFFICE AT 847/705-4131 FOR ANY QUESTIONS ON DRIVEWAYS SHOWN IN THE PLANS; SPECIFICALLY IN REFERENCE TO ADDITIONAL AND/OR RELOCATION/REMOVAL OF A DRIVEWAY.

COMBINATION CONCRETE CURB & GUTTER SHALL BE MEASURED STRAIGHT ACROSS THE DRIVEWAY. NO ADDITIONAL COMPENSATION WILL BE ALLOWED FOR THE CURB & GUTTER TRANSITION.

1 (25) PREFORMED EXPANSION JOINT FILLER WILL NOT BE PAID SEPARATELY, BUT SHALL BE CONSIDERED INCLUDED IN THE COST OF THE P.C.C. DRIVEWAY PAVEMENT OR P.C.C. SIDEWALK.

WHEN THE P.C.C. SIDEWALK EXTENDS THROUGH THE DRIVEWAY, THE THICKNESS OF THE SIDEWALK IN THE DRIVEWAY AREA SHALL BE THE SAME AS THE DRIVEWAY THICKNESS. SIDEWALK WILL BE PAID FOR AS P.C.C. SIDEWALK OF THE THICKNESS SPECIFIED. SIDEWALK CROSS SLOPE THRU DRIVEWAY AREA TO BE A MAXIMUM OF 1/50.

REVISIONS	NAME	DATE
R. SHAH		11-04-95
J. POLLASTRINI		08-12-96
J. POLLASTRINI		12-14-96
A. ABRAS		03-21-97
T. HOLTZ		04-08-97
M. GOMEZ		04-06-01
P. LEFLEUR		04-15-03
R. BORO		01-01-07
R. BORO		06-11-08

ALL DIMENSIONS ARE IN INCHES (MILLIMETERS) UNLESS OTHERWISE NOTED

ILLINOIS DEPARTMENT OF TRANSPORTATION

DRIVEWAY DETAILS

DISTANCE BETWEEN R.O.W. AND FACE OF CURB & EDGE OF SHOULDER >= 15' (4.5 m)

SCALE: VERT. NONE HORIZ. NONE DRAWN BY CHECKED BY

- NOTES:**
- ALL REQUIRED EARTH EXCAVATION TO CONSTRUCT P.C.C. SIDEWALK SHALL BE INCLUDED IN THE COST FOR P.C.C. SIDEWALK.
 - THICKNESS SHALL BE INCREASED TO 7" WHERE SIDEWALK IS ADJACENT TO A DRIVEWAY
 - WHEN FORMS ARE REMOVED FROM THE SIDEWALK EITHER THE SIDEWALK SHALL BE BARRICADED OR BACKFILLED WITHIN 24 HOURS.

P.C.C. SIDEWALK DETAIL

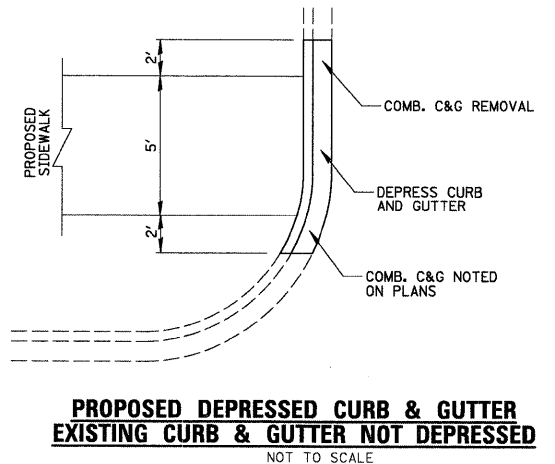

PROPOSED DEPRESSED CURB & GUTTER
EXISTING CURB & GUTTER NOT DEPRESSED
NOT TO SCALE

COMBINATION CONCRETE CURB AND GUTTER, TYPE B-4.12
NOT TO SCALE