

STATE OF ILLINOIS
DEPARTMENT OF TRANSPORTATION

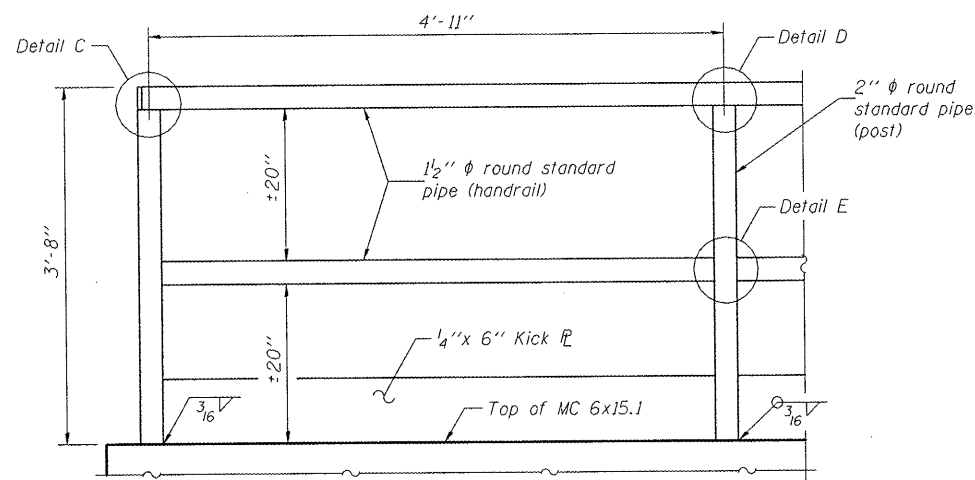

CATWALK RAILING ELEVATION
(Inside Face of Two Element Rail)

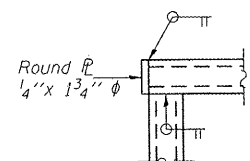

DETAIL C

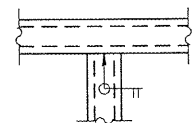

DETAIL D

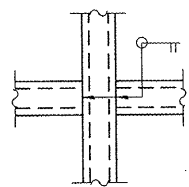

DETAIL E

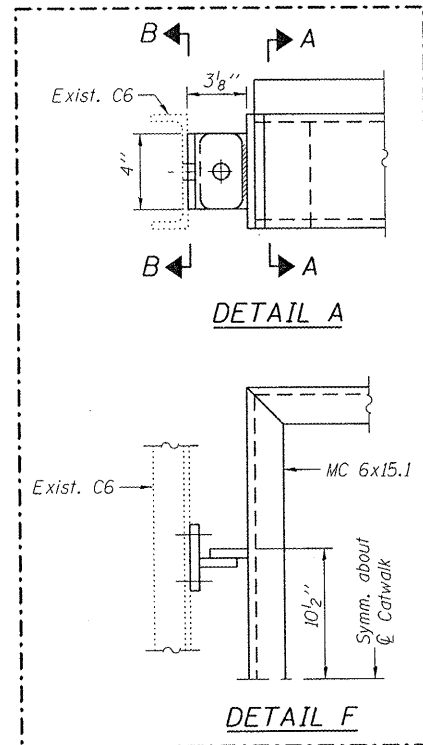

DETAIL A

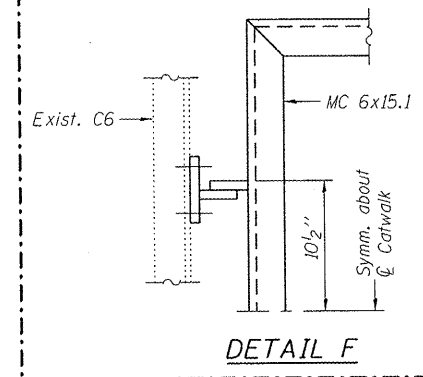

DETAIL F

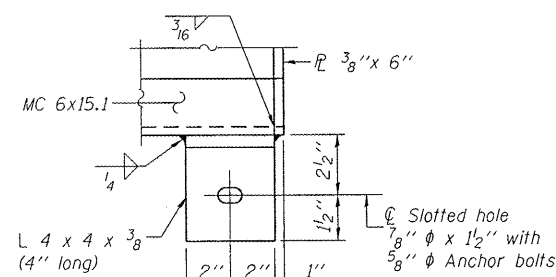

DETAIL B

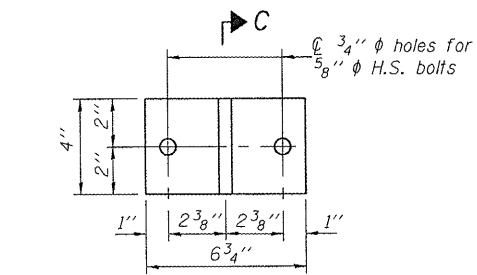

**ELEVATION
CATWALK BRACKET**
(2 Req'd.)

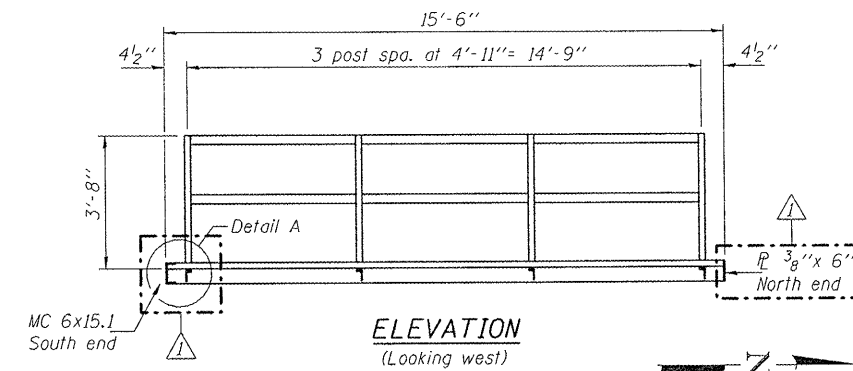

ELEVATION
(Looking west)

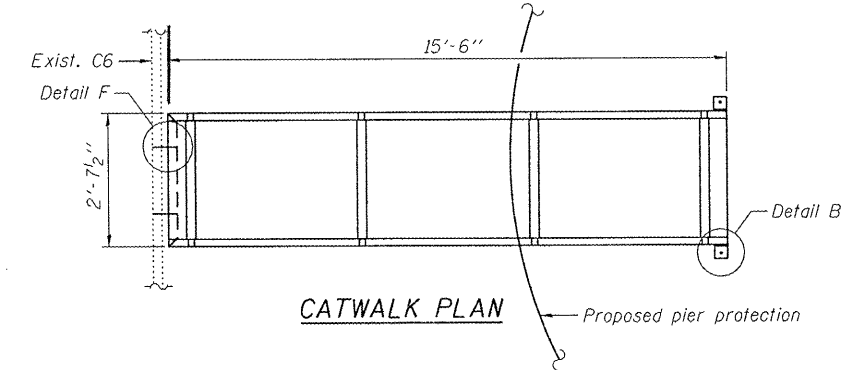

CATWALK PLAN

NOTES

Railing shall be according to Section 509 of the Standard Specifications, except as noted, and will be paid for at the Contract Unit Price per foot for Catwalk.

All material for walkway (except anchor bolts and field drilling of 7/8" diameter holes) shall be paid at the contract price per lineal foot for Catwalk.

All other steel shapes and plates shall conform to the requirements of AASHTO M 270 Grade 36.

If the option of drilling and epoxy grouting the anchor rods is chosen, the Contractor shall use the capsule or the adhesive cartridge type anchor rods that have been previously tested and given a prior approval by the Department. The Contractor shall install these anchor rods in the pre-drilled holes according to the manufacturer's recommendations and procedures. The capsule or the adhesive cartridge shall be sealed with pre-measured amounts of the adhesive chemical.

All posts, railing, splices, anchor devices, and bent plates shall be painted using the specified paint system for Structural Steel.

The Inorganic Zinc Rich Primer/Acrylic/Acrylic Paint System shall be used for shop and field painting of new structural steel except where otherwise noted. The color of the final finish coat for all interior steel surfaces shall be gray, Munsell No. 5B 7/1. The color of the final finish coat for the exterior and bottom flange of the fascia beams shall be gray, Munsell No. 5B 7/1. See Special Provision for "Cleaning and Painting New Metal Structures".

BILL OF MATERIAL

Item	Unit	Quantity
Catwalk	Foot	15.5
Anchor Bolts 5/8" diameter	Each	2

**CATWALK DETAILS
STRUCTURE NO. 086-0001**

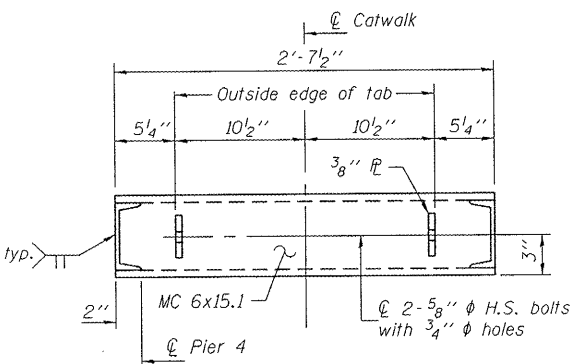

SECTION A-A

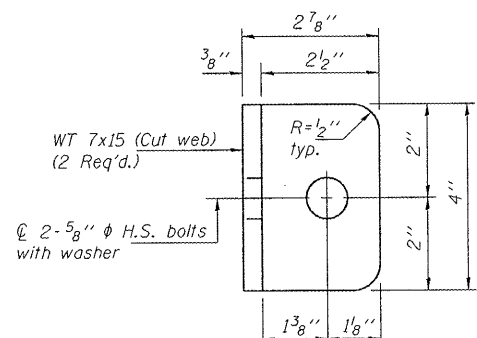

SECTION C-C

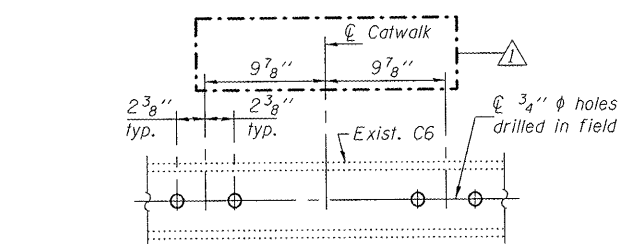

SECTION B-B

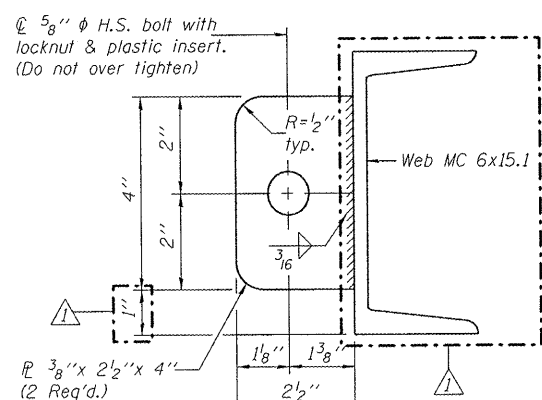

TAB DETAIL

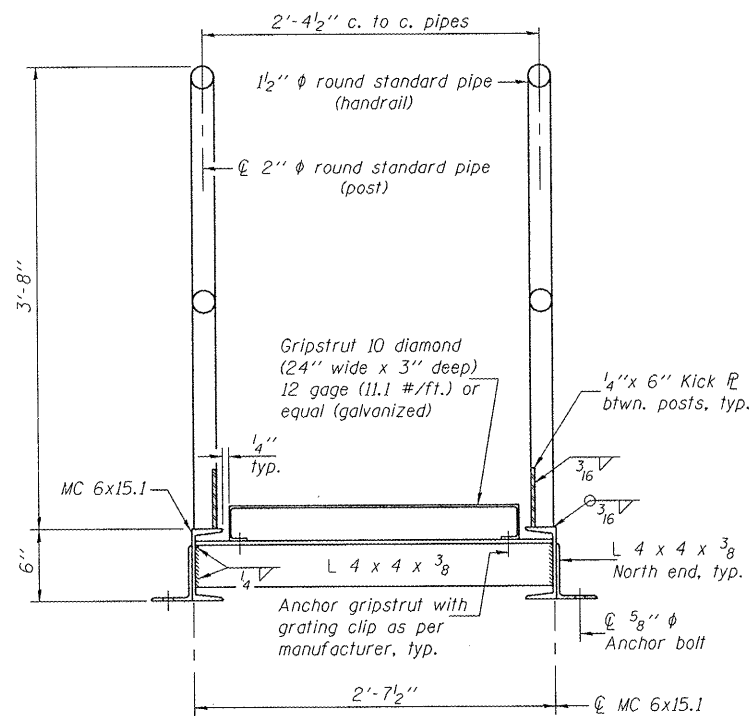

CROSS SECTION

DESIGNED	Patrick M. Petrone
CHECKED	Jay D. Edwards
DRAWN	h.t. duong
CHECKED	PMP/JDE

EXAMINED	August 14, 2009
PASSED	Thomas J. Donagale ENGINEER OF BRIDGE DESIGN
	Ralph E. Anderson ENGINEER OF BRIDGES AND STRUCTURES

SHEET NO. 4 4 SHEETS	F.A.P. RTE.	SECTION	COUNTY	TOTAL SHEETS	SHEET NO.
	757	D6 FLORENCE PIER PROTECTION	SCOTT	9	7
			CONTRACT NO. 72D07		
FED. ROAD DIST. NO.		ILLINOIS FED. AID PROJECT			