

SECTION A-A

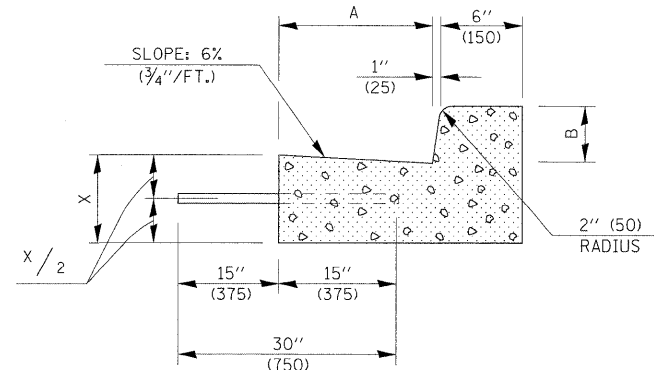

SECTION B-B

* INCREASE TO 2" (50 mm) WHERE IN THE PLANS IT IS SPECIFIED THAT THESE SPECIAL INLETS ARE TO BE CONSTRUCTED AS OUTLETS. ALL OUTLET LOCATIONS WILL BE CONFIRMED BY THE ENGINEER.

GENERAL NOTES

1. CLASS SI CONCRETE SHALL BE USED THROUGHOUT.
2. TIE BARS SHALL BE NO. 6 (NO. 20) AT 24" (600 mm) CENTERS UNLESS OTHERWISE SHOWN. SPECIAL INLETS AND OUTLETS SHALL BE TIED TO THE PAVEMENT IN ACCORDANCE WITH DETAILS FOR LONGITUDINAL CONSTRUCTION JOINT SHOWN ON STANDARD 420001.
3. TIE BARS SHOWN ABOVE WILL NOT BE PAID FOR SEPARATELY BUT SHALL BE CONSIDERED AS INCIDENTAL TO CLASS SI CONCRETE (OUTLET).
4. WHEN SPECIAL INLET IS CONSTRUCTED ADJACENT TO FLEXIBLE PAVEMENT, THE TIE BARS SHALL BE OMITTED AND ALL CONSTRUCTION JOINTS SHALL BE PROVIDED WITH A DOWEL BAR CONFORMING TO ARTICLE 1006.11(b).
5. THIS WORK WILL BE PAID FOR AT THE CONTRACT UNIT PRICE PER CU. YD. (m³) FOR CLASS SI CONCRETE (OUTLET) WHICH PRICE SHALL INCLUDE ALL LABOR AND MATERIAL AS SPECIFIED AND NO ADDITIONAL COMPENSATION WILL BE ALLOWED.

| | B-6.12 (B-15.30) | B-9.12 (B-22.30) | B-6.18 (B-15.45) | B-9.18 (B-22.45) | B-6.24 (B-15.60) | B-9.24 (B-22.60) |
|----------------------------|---------------------|---------------------|---------------------|---------------------|---------------------|---------------------|
| A | 12" (300) | 12" (300) | 12" (300) | 12" (300) | 18" (450) | 18" (450) |
| B | 6" (150) | 6" (150) | 9" (225) | 9" (225) | 6" (150) | 6" (150) |
| X | 9" (225) | 10" (250) | 9" (225) | 10" (250) | 9" (225) | 10" (250) |
| CU. YD. (m ³) | 0.37 (0.28) | 0.42 (0.32) | 0.38 (0.29) | 0.42 (0.32) | 0.44 (0.34) | 0.49 (0.37) |
| CLASS SI CONCRETE (OUTLET) | 0.42 (0.32) | 0.38 (0.29) | 0.44 (0.34) | 0.49 (0.37) | 0.45 (0.34) | 0.50 (0.38) |
| | 0.56 (0.43) | 0.52 (0.40) | 0.57 (0.44) | | | |

CLASS SI CONCRETE (OUTLET)

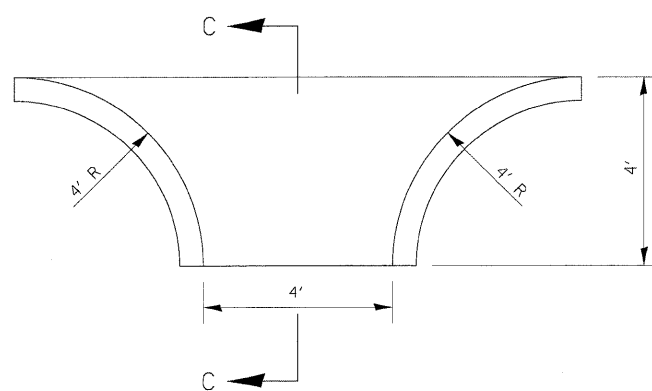

CURB OUTLET

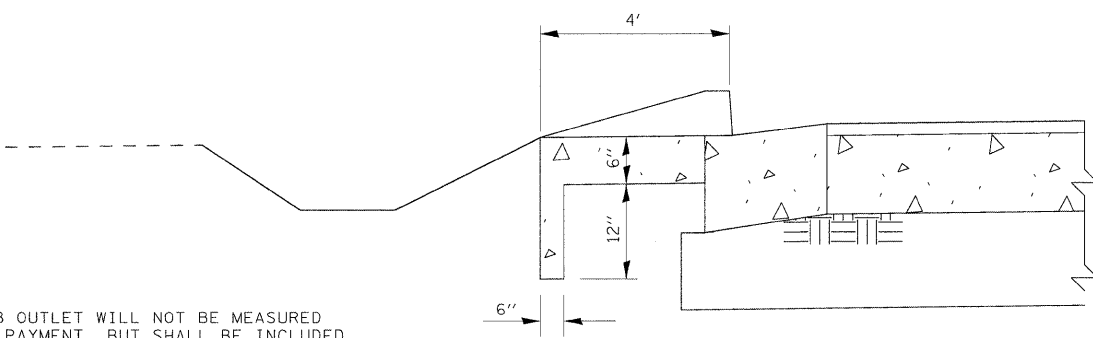

SECTION C-C

NOTE: CURB OUTLET WILL NOT BE MEASURED FOR PAYMENT, BUT SHALL BE INCLUDED IN THE CONTRACT UNIT PRICE FOR "COMBINATION CONCRETE CURB AND GUTTER TYPE B-6.24".

CURB OUTLET

Note: All dimensions are in INCHES (millimeters) unless otherwise shown.

| | | | | | | | | | | | |
|---|---------------------|----------------|-----------------|---|------------------------|----------------------------------|---------------------------|----------|--------------|-----------|--|
| FILE NAME = | USER NAME = moakley | DESIGNED - BWC | REVISED - 11/06 | STATE OF ILLINOIS DEPARTMENT OF TRANSPORTATION | ROADWAY DETAILS | F.A.P. RTE. | SECTION | COUNTY | TOTAL SHEETS | SHEET NO. | |
| P:\0340702Hutsonville\Drawings\Details\mo | scodetails.dgn | DRAWN - | REVISED - | | | 332 | 22N | CRAWFORD | 22 | 13 | |
| PLOT SCALE = 20.0000' / IN. | | CHECKED - | REVISED - | | | CONTRACT NO. 74300 | | | | | |
| PLOT DATE = 12/16/2008 | | DATE - | REVISED - | | | FED. ROAD DIST. NO. | ILLINOIS FED. AID PROJECT | | | | |
| SCALE: | | | | | | SHEET NO. OF SHEETS STA. TO STA. | | | | | |