

SECTION C-C

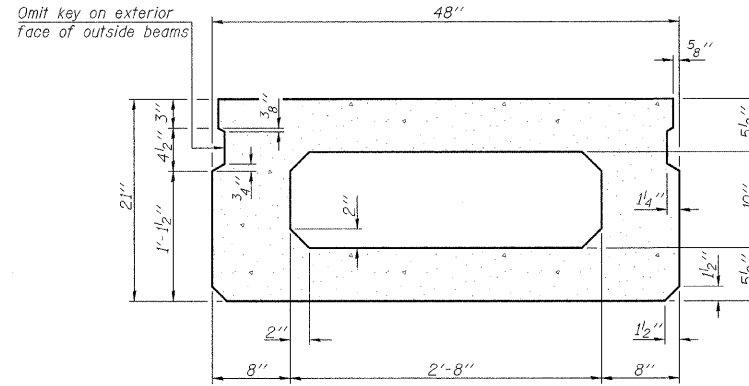

SECTION A-A
(Showing dimensions)

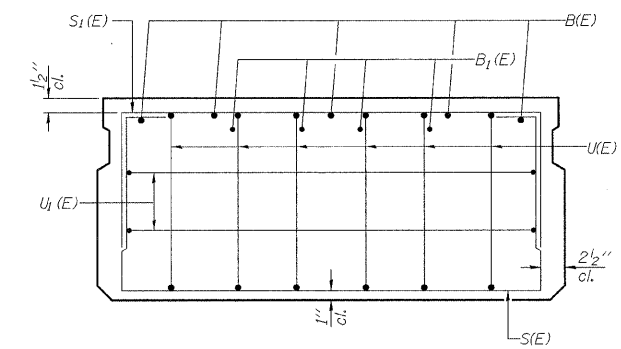

VIEW B-B

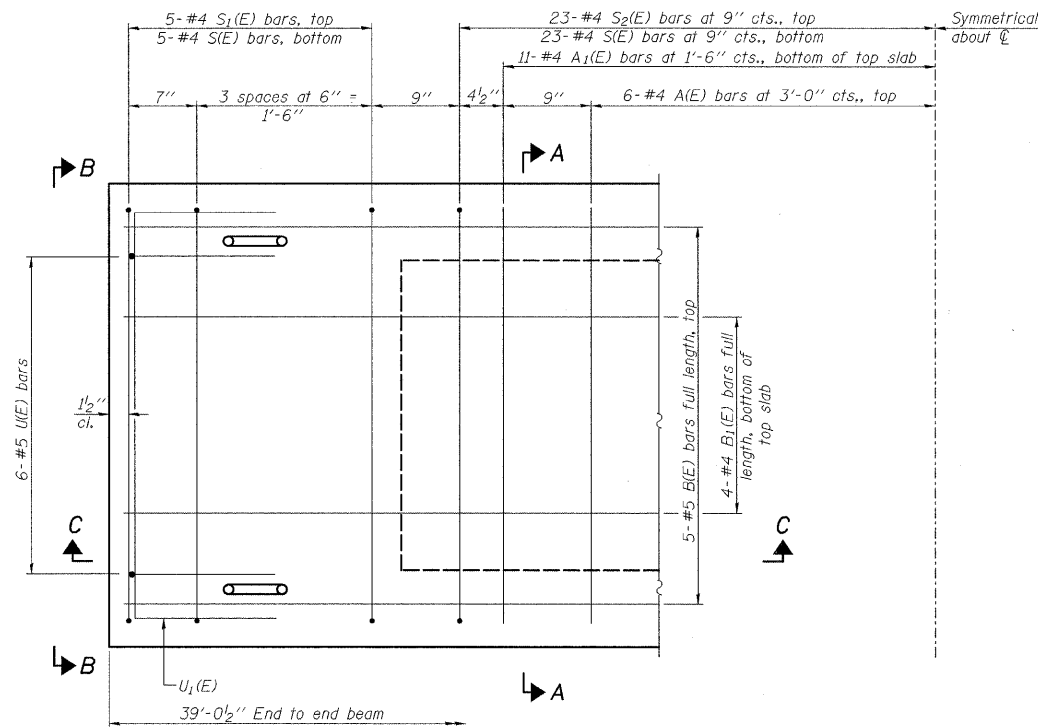

PLAN VIEW

Note: Spacing of S(E) and S2(E) bars may be adjusted up to 4\"/>

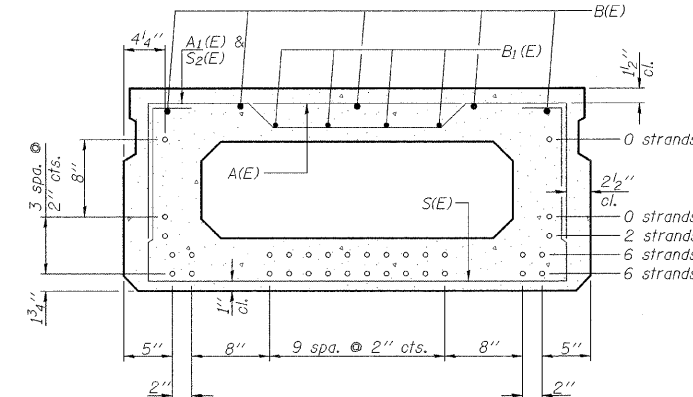

SECTION A-A

(Showing reinforcement and permissible strand locations)

Note: Place the number of strands specified in each row symmetrically about the centerline of beam in the permissible strand locations shown.

BAR LIST
ONE BEAM ONLY
(For Information Only)

Bar	No.	Size	Length	Shape
A(E)	12	#4	3'-7"	—
A1(E)	22	#4	3'-10"	—
B(E)	5	#5	38'-9"	—
B1(E)	4	#4	38'-9"	—
S(E)	56	#4	7'-5"	□
S1(E)	10	#4	5'-11"	□
S2(E)	46	#4	6'-2"	□
U(E)	12	#5	4'-0"	□
U1(E)	4	#4	6'-0"	□

Note: See Sheet B5 for additional details and Bill of Material.

PD-2148-0

10-1-08

DESIGNED - JML	REVISED -
DRAWN - DJM	REVISED -
CHECKED - MSW	REVISED -
DATE - 06/22/09	REVISED -

EFFINGHAM COUNTY DEPARTMENT OF HIGHWAYS

21" x 48" PPC DECK BEAM

T.R. 68 OVER FULFER CREEK
SECTION 05-07106-00-BR
EFFINGHAM COUNTY
STATION 9+96.25 STRUCTURE NO. 025-3318

T.R.	SECTION	COUNTY	TOTAL SHEETS	SHEET NO.
68	05-07106-00-BR	EFFINGHAM	25	10
FED. ROAD DIST. NO. 7 ILLINOIS FED. AID PROJECT			CONTRACT NO. 95392	

FARNSWORTH GROUP, INC.

CONSULTING ENGINEERS - 2709 MCGRAW DRIVE BLOOMINGTON, ILLINOIS 61704 (309) 663-8435 / (309) 663-1571 FAX

24-7945