

STATE OF ILLINOIS
DEPARTMENT OF TRANSPORTATION

F.A.I. RTE.	SECTION	COUNTY	TOTAL SHEETS	SHEET NO.
72	(86-9) BRR-1	SCOTT	7	1
		ILLINOIS	CONTRACT NO. 72M37	

FOR INDEX OF SHEETS, SEE SHEET NO. 2

PROPOSED CONTRACT MAINTENANCE

FAI ROUTE 72 (I-72)
SECTION (86-9) BRR-1
PROJECT (STATE ONLY)
BRIDGE REPAIRS
SCOTT COUNTY

C-96-137-20



PROJECT LOCATION
SN 086-0037 & 0038
I-72 OVER IL 100
AT THE BLUFFS INTERCHANGE

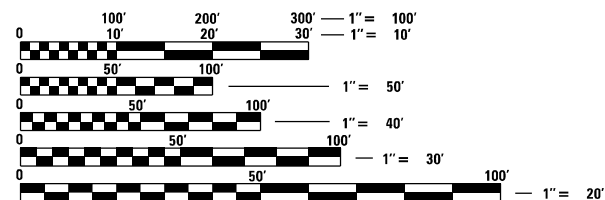

FULL SIZE PLANS HAVE BEEN PREPARED USING STANDARD ENGINEERING SCALES. REDUCED SIZED PLANS WILL NOT CONFORM TO STANDARD SCALES. IN MAKING MEASUREMENTS ON REDUCED PLANS, THE ABOVE SCALES MAY BE USED.

J.U.L.I.E.
JOINT UTILITY LOCATION INFORMATION FOR EXCAVATION
1-800-892-0123
OR 811

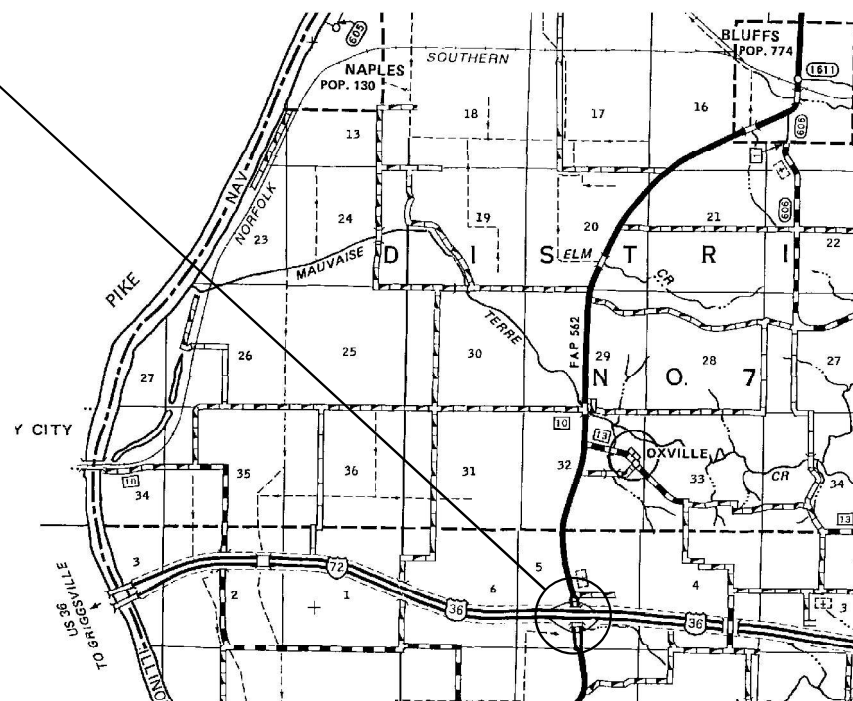

GROSS LENGTH = 175 FT. = 0.03 MILE
NET LENGTH = 175 FT. = 0.03 MILE

BRIDGE MAINTENANCE ENGINEER: BRANDON DUDLEY - (217) 785-9290

CONTRACT NO. 72M37

D-96-107-20

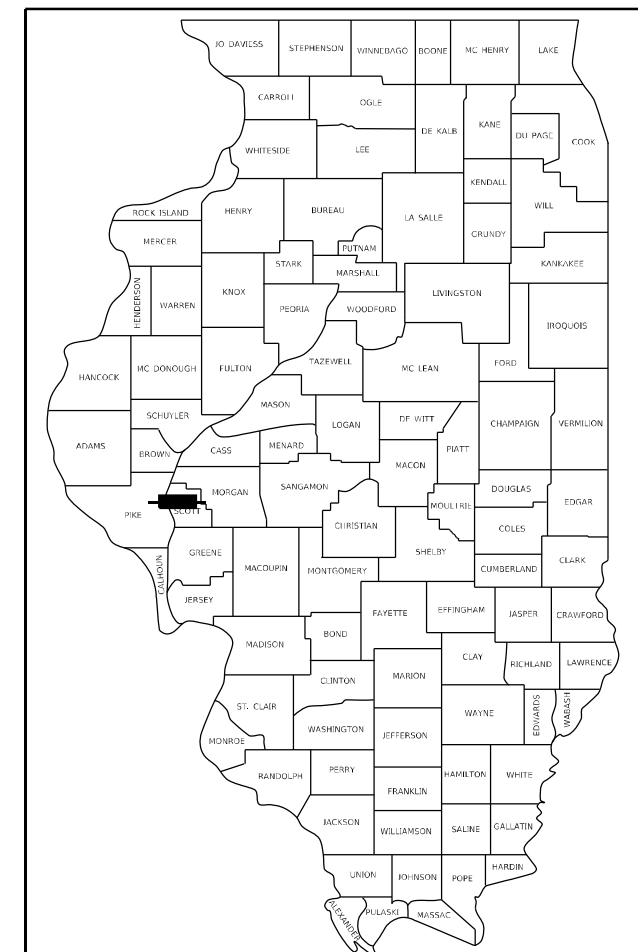

LOCATION OF SECTION INDICATED THIS: - [black rectangle] -

STATE OF ILLINOIS
DEPARTMENT OF TRANSPORTATION

SUBMITTED June 29 20 20
John P. Meyer REGIONAL ENGINEER
August 14, 2020
Scott A. Clark ENGINEER OF DESIGN AND ENVIRONMENT
August 14, 2020
James J. ... DIRECTOR OF HIGHWAYS PROJECT IMPLEMENTATION

PRINTED BY THE AUTHORITY
OF THE STATE OF ILLINOIS



INDEX OF SHEETS

- 1 COVER SHEET
- 2 INDEX, STANDARDS, SIGNATURES, & GENERAL NOTES
- 3 SUMMARY OF QUANTITIES
- 4-7 SN 086-0037 & 0038 BRIDGE PLANS

STANDARDS

- 000001-07
- 001001-02
- 001006
- 701001-02
- 701006-05
- 701101-05
- 701106-02
- 701301-04
- 701901-08

GENERAL NOTES:

STATE OF ILLINOIS DEPARTMENT OF TRANSPORTATION DIVISION OF HIGHWAYS DISTRICT 6	
EXAMINED <u>June 15</u> 20 <u>20</u>	 ENGINEER OF OPERATIONS
EXAMINED <u>June 26</u> 20 <u>20</u>	 ENGINEER OF PROJECT IMPLEMENTATION
EXAMINED <u>June 12</u> 20 <u>20</u>	 ENGINEER OF PROGRAM DEVELOPMENT

MODEL: Default
FILE NAME: C:\OPERATIONS\Bridges\Bridges\Plans_CAD\72M37 - 086-0037 & 0038 beam ends\indexsheet.dgn

REV. - MS

	USER NAME = dudleybm	DESIGNED -	REVISED -	STATE OF ILLINOIS DEPARTMENT OF TRANSPORTATION	INDEX OF SHEETS, GENERAL NOTES, HIGHWAY STANDARDS, & SIGNATURES	F.A.I. RTE.	SECTION	COUNTY	TOTAL SHEETS	SHEET NO.	
		DRAWN -	REVISED -			72	(86-9) BRR-1	SCOTT	7	2	
	PLOT SCALE = 100.0000' / in.	CHECKED -	REVISED -			CONTRACT NO. 72M37					
	PLOT DATE = 6/29/2020	DATE -	REVISED -			SCALE:		SHEET OF SHEETS		STA. TO STA.	

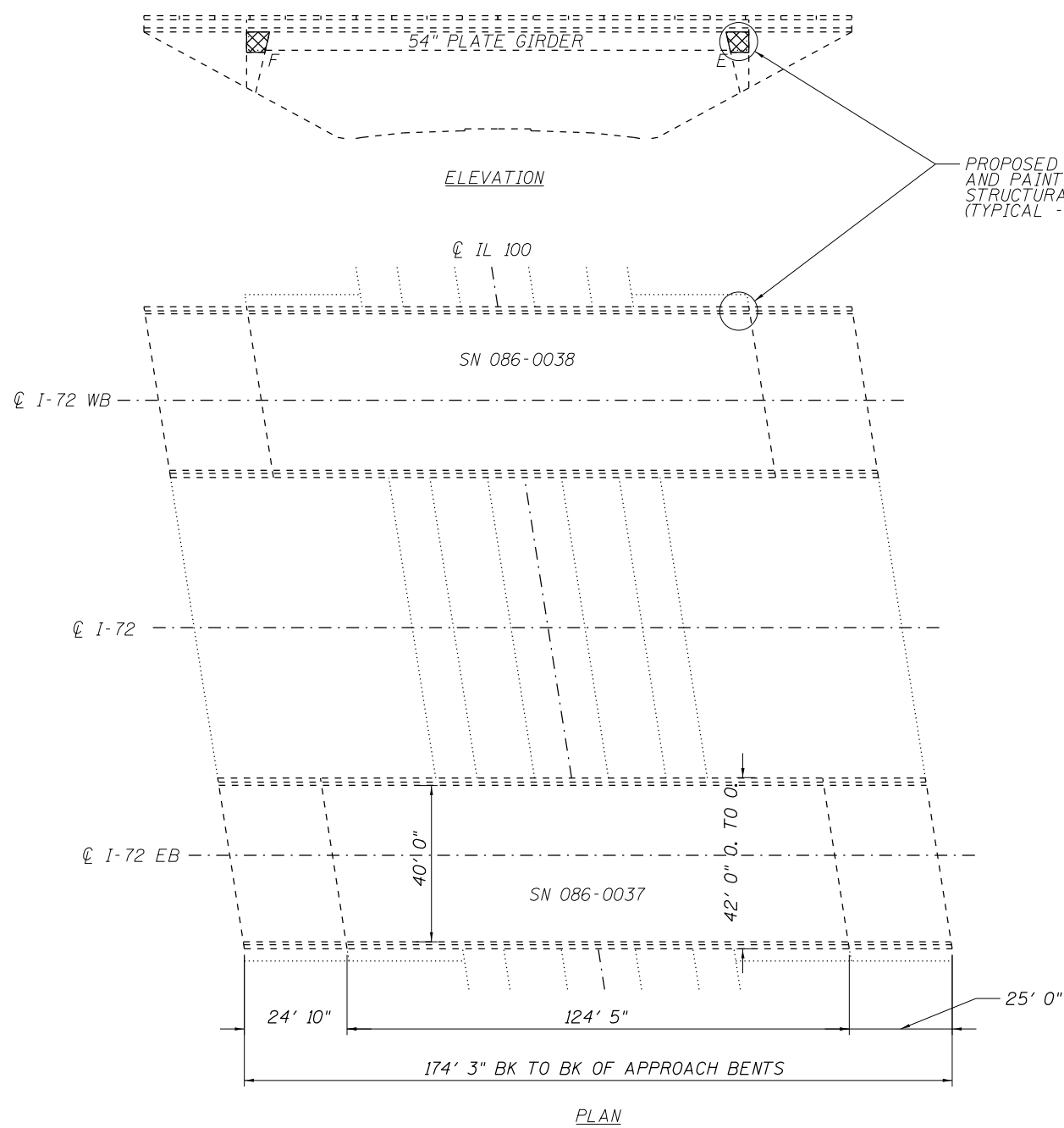

Expires 11-30-2020
David Carl Puzey
 8/13/2020

STRUCTURE GENERAL NOTES:

PLAN DIMENSIONS AND DETAILS RELATIVE TO EXISTING PLANS ARE SUBJECT TO NOMINAL CONSTRUCTION VARIATIONS. THE CONTRACTOR SHALL FIELD VERIFY EXISTING DIMENSIONS AND DETAILS AFFECTING NEW CONSTRUCTION AND MAKE NECESSARY APPROVED ADJUSTMENTS PRIOR TO CONSTRUCTION OR ORDERING OF MATERIALS. SUCH VARIATIONS SHALL NOT BE CAUSE FOR ADDITIONAL COMPENSATION FOR A CHANGE IN THE SCOPE OF WORK, HOWEVER, THE CONTRACTOR WILL BE PAID FOR THE QUANTITY ACTUALLY FURNISHED AT THE UNIT PRICE BID FOR THE WORK.

ALL STRUCTURAL STEEL SHALL BE AASHTO M270 GRADE 50 UNLESS OTHERWISE NOTED.

EXISTING STRUCTURAL STEEL THAT WILL BE IN CONTACT WITH NEW STRUCTURAL STEEL SHALL BE CLEANED AND PAINTED PRIOR TO ERECTION AS REQUIRED BY THE SPECIAL PROVISION "CLEANING AND PAINTING CONTACT SURFACE AREAS OF EXISTING STEEL STRUCTURES".

ALL NEW STRUCTURAL STEEL SHALL BE HOT-DIP GALVANIZED. SEE SPECIAL PROVISIONS FOR "HOT DIP GALVANIZING FOR STRUCTURAL STEEL".

AREAS TO BE WASHED SHALL BE PER THE SPECIAL PROVISIONS.

TOTAL BILL OF MATERIAL (086-0037 & 0038)

ITEM	UNIT	QUANTITY
Concrete Removal	Cu Yd	2.6
Cleaning and Painting Exposed Rebar	Sq Ft	32
Structural Steel Repair	Pound	930
Bridge Washing No. 1	Each	1
Bridge Washing No. 2	Each	1

MODEL: Default
 FILE: \\nrcs\c0\OPERATIONS\bridge\bridge\BRR\BRR-1\086-0037 & 0038 beam end\plan\bridge.dgn

USER NAME = dudleybm	DESIGNED - BRANDON DUDLEY	REVISED -
	DRAWN - BRANDON DUDLEY	REVISED -
PLOT SCALE = 100.0000' / in.	CHECKED - JASON JONES	REVISED -
PLOT DATE = 6/29/2020	DATE - 5/28/2020	REVISED -

STATE OF ILLINOIS
DEPARTMENT OF TRANSPORTATION

BRIDGE PLAN & ELEVATION
SN 086-0037 & 0038

SCALE: SHEET 1 OF 4 SHEETS STA. TO STA.

F.A.I. RTE.	SECTION	COUNTY	TOTAL SHEETS	SHEET NO.
72	(86-9) BRR-1	SCOTT	7	4
ILLINOIS FED. AID PROJECT			CONTRACT NO. 72M37	

NOTES

Fasteners shall be high strength bolts. Bolts $\frac{3}{4}"\varnothing$, open holes $1\frac{1}{16}"\varnothing$, unless otherwise noted.
 Cost of removal and re-installation of all members necessary to complete the work as detailed on the plans and as specified in the Special Provisions shall be included with Structural Steel Repair.
 The existing structural steel coating contains lead. The Contractor shall take appropriate precautions to deal with the presence of lead on this project.

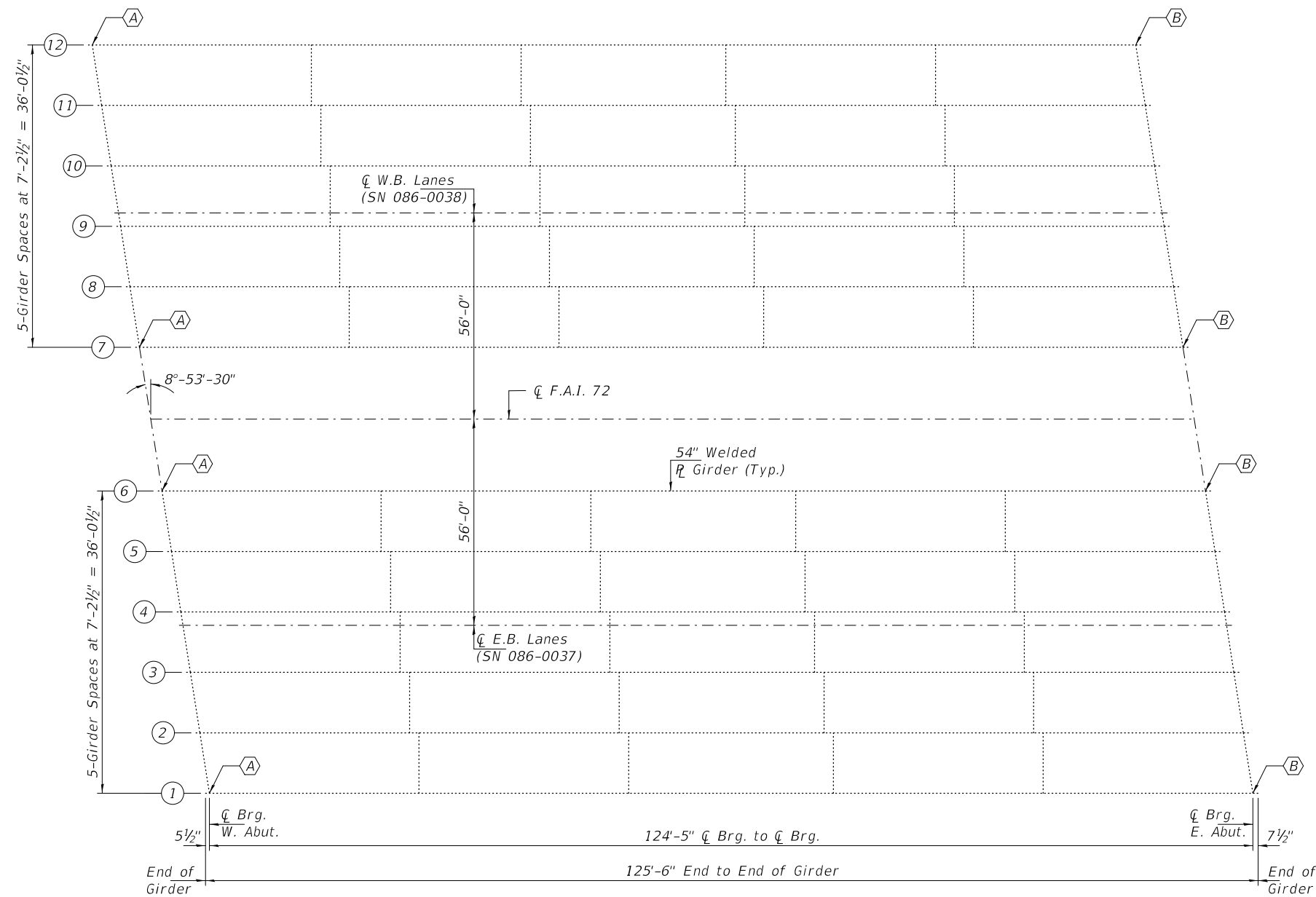

FRAMING PLAN

- (A) - Girder End Repair "A"
- (B) - Girder End Repair "B"

BILL OF MATERIAL

ITEM	UNIT	QUANTITY
Structural Steel Repairs	Pound	930

DESIGNED - SMR
 CHECKED - ATH
 DRAWN - STEFFEN
 CHECKED - SMR ATH

EXAMINED
 PASSED
Timothy A. ...
 ENGINEER OF STRUCTURAL SERVICES
Carl ...
 ENGINEER OF BRIDGES AND STRUCTURES

DATE - AUGUST 13, 2020
 REVISED -
 REVISED -

**STATE OF ILLINOIS
 DEPARTMENT OF TRANSPORTATION**

**FRAMING PLAN
 I-72 OVER IL RTE. 100
 SN 086-0037 (E.B.) & -0038 (W.B.)**
 SHEET NO. 1 OF 2 SHEETS

F.A. RTE.	SECTION	COUNTY	TOTAL SHEETS	SHEET NO.
408	(86-9) BRR-1	SCOTT	7	6
CONTRACT NO. 72M37				
ILLINOIS FED. AID PROJECT				

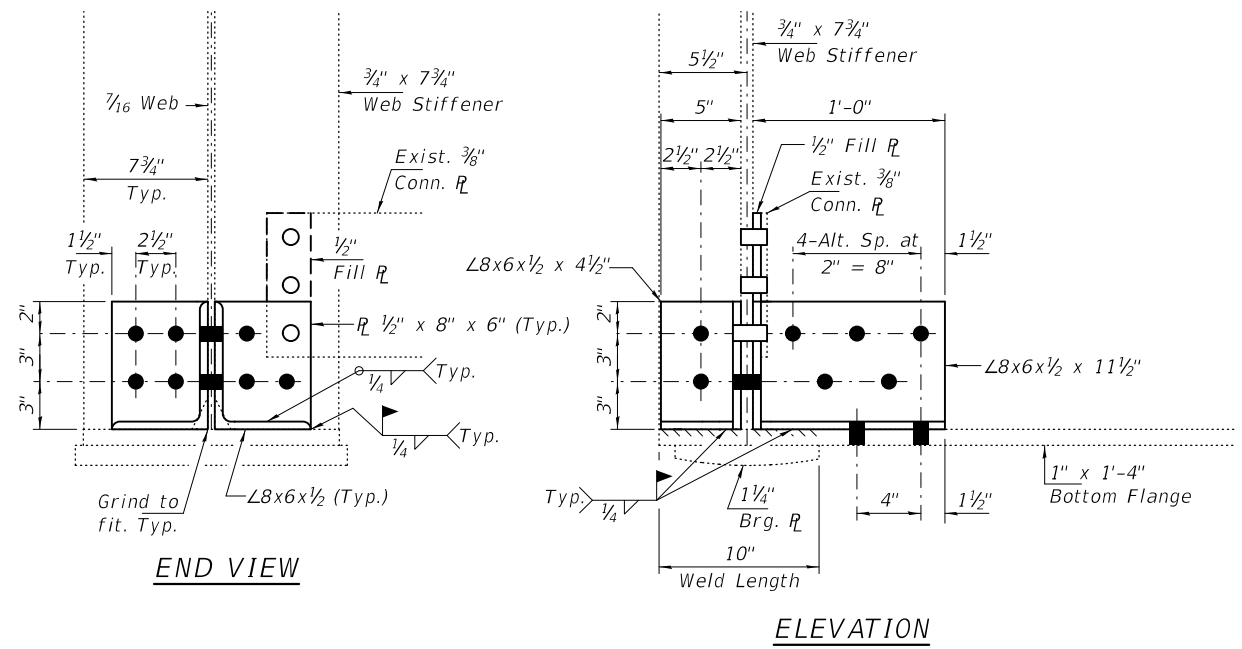

GIRDER REPAIR "A"
(4-Locations)

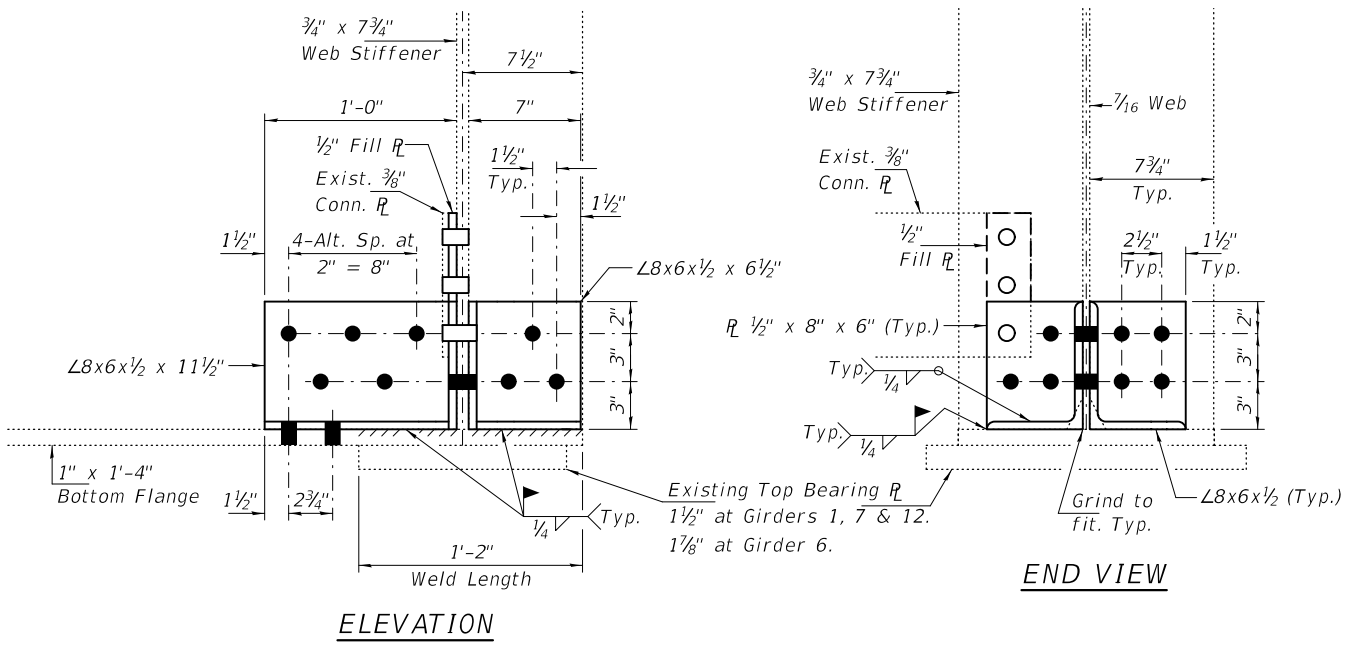

GIRDER REPAIR "B"
(4-Locations)

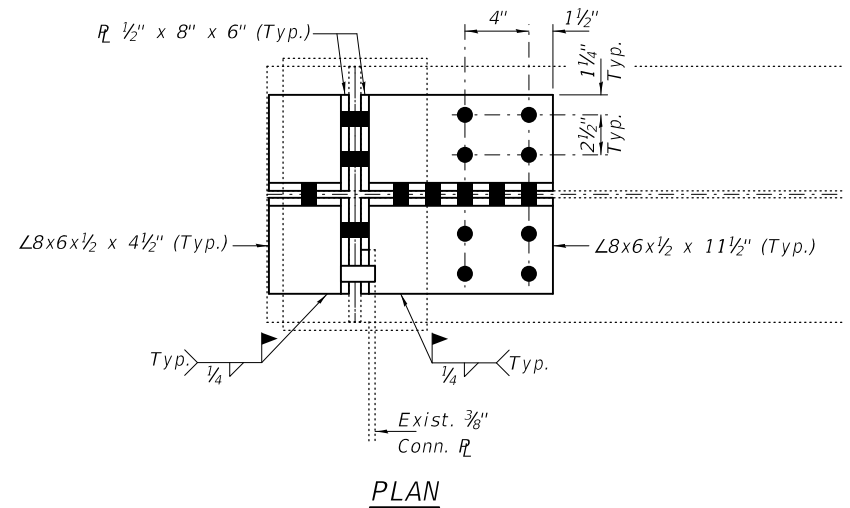

PLAN

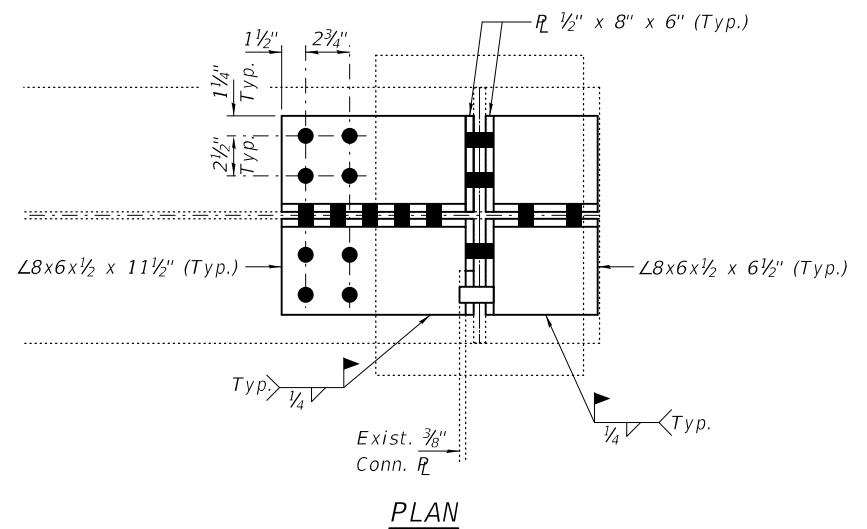

PLAN

BOLT HOLE LEGEND

- - Field drill using holes in existing steel as template.
- - Field drill using holes in new steel as template.

DESIGNED - SMR	EXAMINED - <i>Timothy A. Daulton</i>
CHECKED - ATH	ENGINEER OF STRUCTURAL SERVICES
DRAWN - STEFFEN	PASSED - <i>Carl Ruyter</i>
CHECKED - SMR ATH	ENGINEER OF BRIDGES AND STRUCTURES

DATE - AUGUST 13, 2020
REVISED -
REVISED -

**STATE OF ILLINOIS
DEPARTMENT OF TRANSPORTATION**

**GIRDER END REPAIR DETAILS
SN 086-0037 (E.B.) & -0038 (W.B.)**

F.A. RTE. 408	SECTION (86-9) BRR-1	COUNTY SCOTT	TOTAL SHEETS 7	SHEET NO. 7
CONTRACT NO. 72M37				