

STATE OF ILLINOIS
DEPARTMENT OF TRANSPORTATION

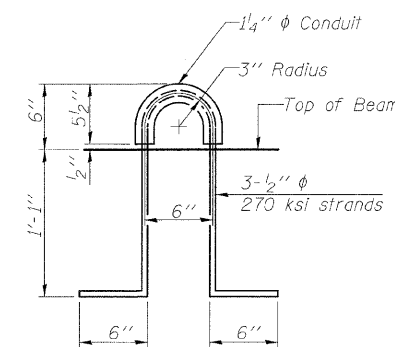
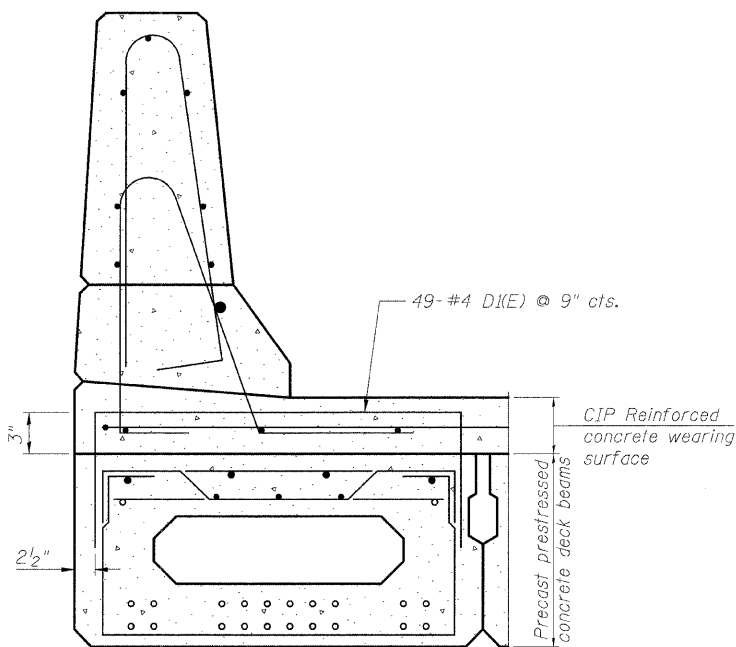
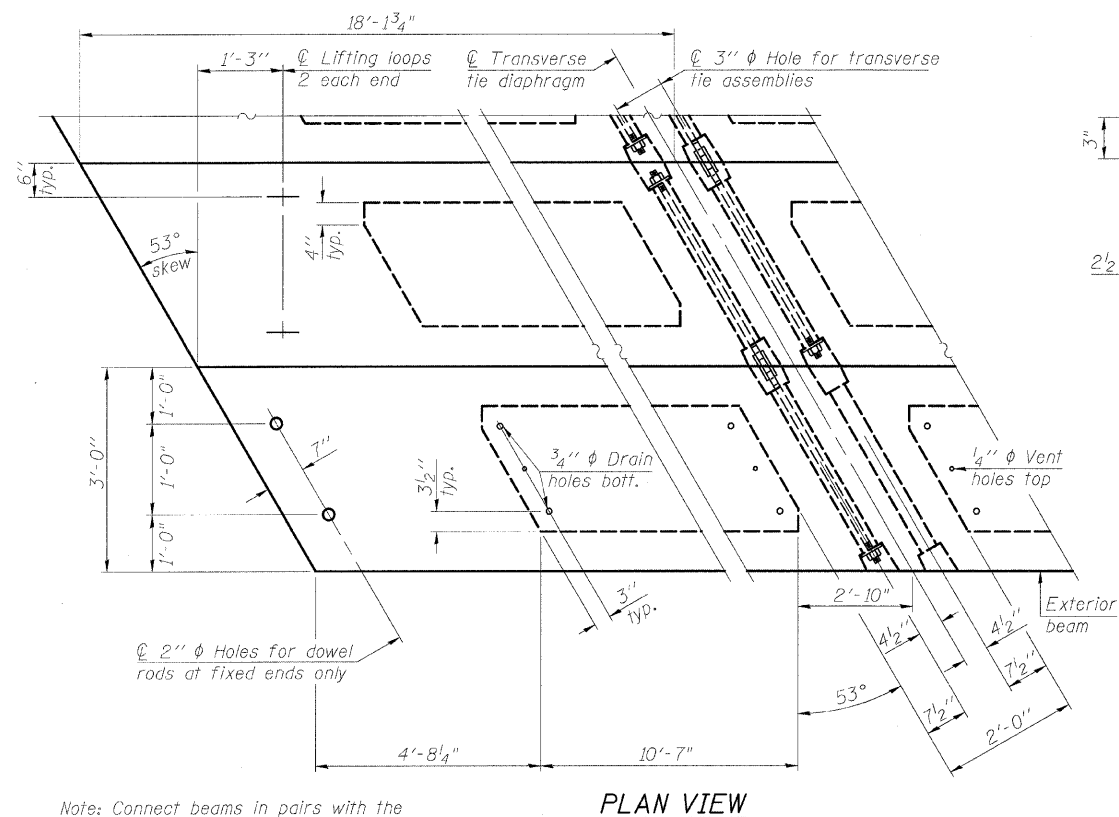
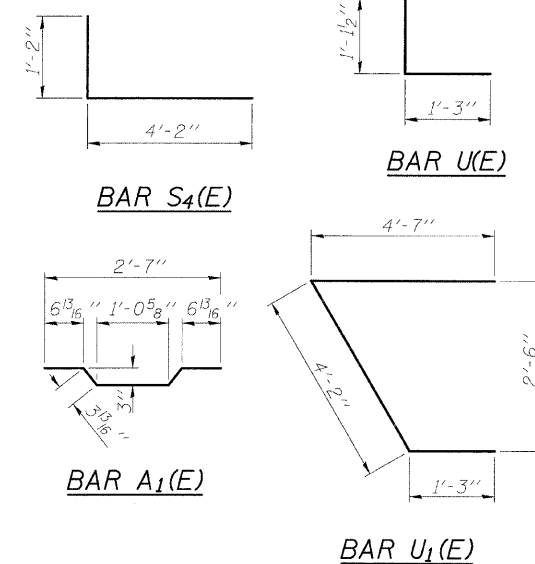
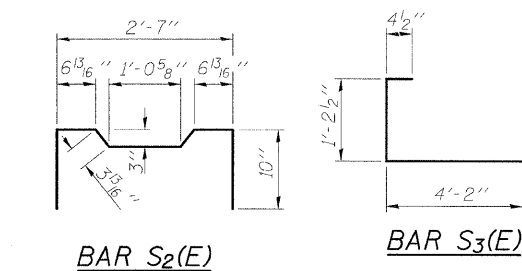
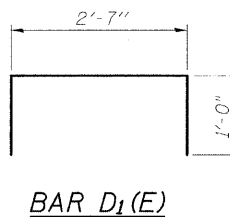
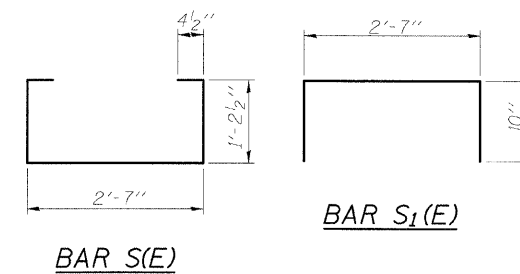
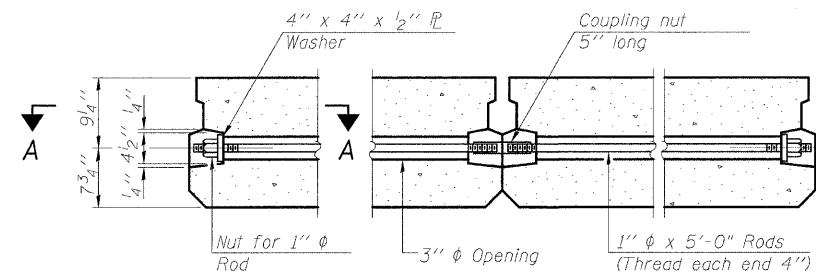
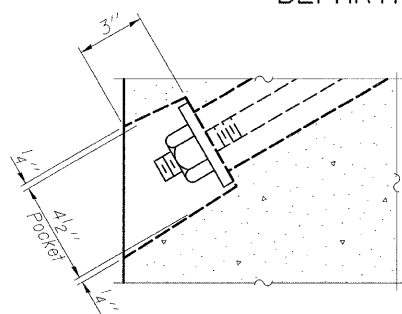
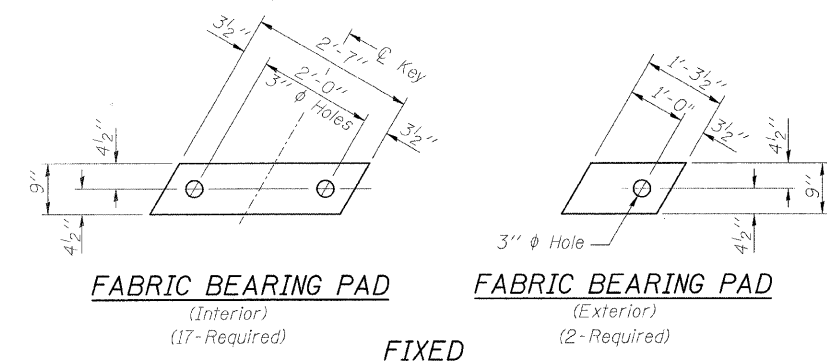
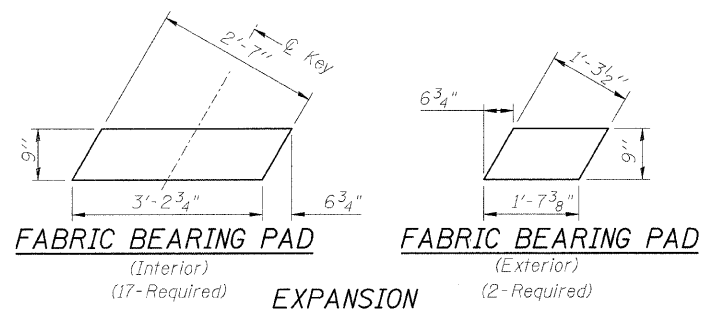

CROSS SECTION

LIFTING LOOP DETAIL

NOTES

1. Prestressing steel shall be uncoated high strength, low relaxation 7-wire strand, Grade 270. The nominal diameter shall be 1/2" and the nominal cross-sectional area shall be 0.153 sq. in.

2. The 1" rods in the transverse tie assembly shall be tightened to a snug fit and the threads set. Pockets on exterior faces of bridge shall be filled with grout after transverse tie assembly is in place.

3. Reinforcement bars shall conform to ASTM A 706, Grade 60. (See Special Provisions).

4. Two 3/8" fabric adjusting shims of the dimensions of the exterior bearing pad shall be provided for each bearing pad location.

5. A minimum 2 1/2" lifting pin shall be used to engage the lifting loops during handling.

6. Corrosion Inhibitor, per Article 1020.05(b)(12) and 1021.06 of the Standard Specifications, shall be used in the concrete for precast prestressed concrete deck beams.

7. Compressive strength of prestressed concrete, f'c, shall be 6000 psi.

8. Compressive strength of prestressed concrete at release, f'ci, shall be 5000 psi.

9. For half cross-section, see Sheet S-7.

BILL OF MATERIAL

Precast Prestressed Conc. Deck Bms. (17" depth)	Sq. Ft.	2,178
-------------------------------------------------	---------	-------

Note: Connect beams in pairs with the transverse tie configuration shown.

DESIGNED	B. Sauter
CHECKED	E. Mroczek
DRAWN	R. Danley
CHECKED	B. Sauter

Ciorba Group, Inc.
CONSULTING ENGINEERS
5507 North Cumberland Avenue, Suite 402 Chicago, Illinois 60656
Tel. 773.775.4009 Fax 773.775.4014 Email chicago@ciorba.com

PD-1736-RD 5-16-08

**17" X 36" PPC DECK BEAM
DETAILS
US 6 (RAILROAD AVE.) OVER I & M CANAL
STA. 112+00
S.N. 099-0098**

SHEET NO. S-5	F.A.U R.T.E.	SECTION	COUNTY	TOTAL SHEETS	SHEET NO.
	0318	DB-1-R-B	WILL	40	27
S-14 SHEETS	CONTRACT NO. 60D88				
FED. ROAD DIST. NO.		ILLINOIS FED. AID PROJECT			