

F.A.I. RTE.	SECTION	COUNTY	TOTAL SHEETS	SHEET NO.
57	•	WILL	303	12
STA.	TO STA.			
FED. ROAD DIST. NO.	ILLINOIS	FED. AID PROJECT		
CONTRACT No. 62253	*991&2) R-389-118-1-BR-2			

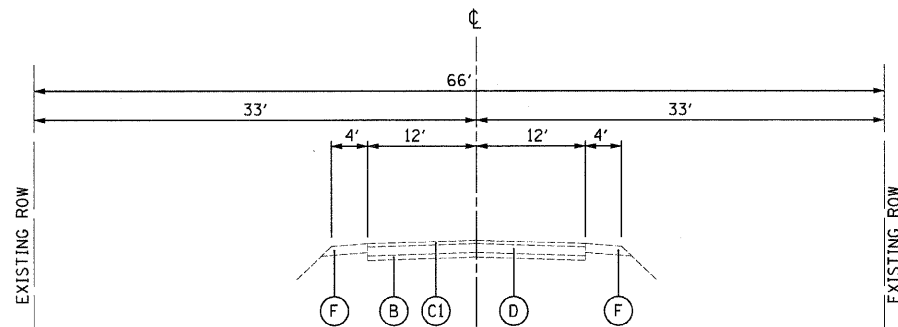

EXISTING
TYPICAL SECTION
MANHATTAN-MONEE ROAD
① STA. 14017+50 TO STA. 14024+25

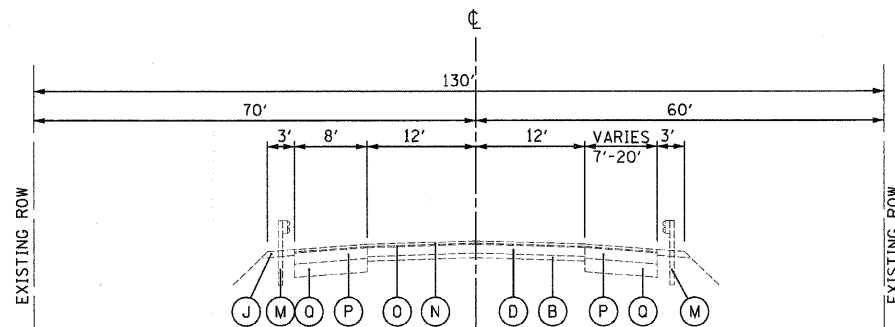

EXISTING
TYPICAL SECTION
MANHATTAN-MONEE ROAD
④ STA. 14030+00 TO STA. 14036+39

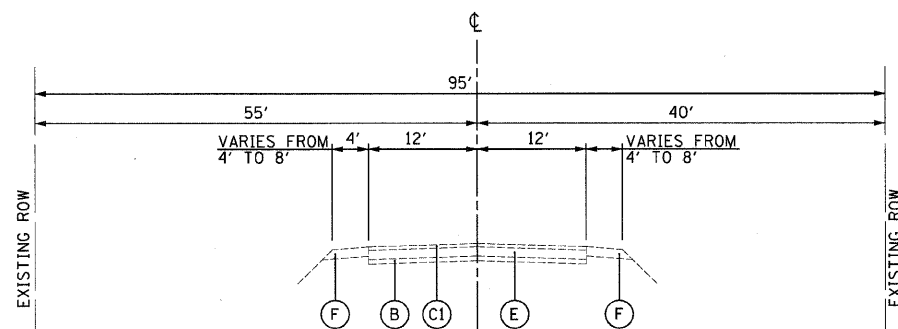

EXISTING
TYPICAL SECTION
MANHATTAN-MONEE ROAD
② STA. 14024+25 TO STA. 14027+15

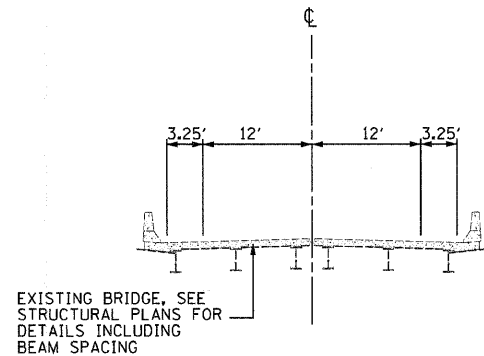

EXISTING
TYPICAL SECTION
MANHATTAN-MONEE ROAD
⑤ STA. 14036+39 TO STA. 14038+56

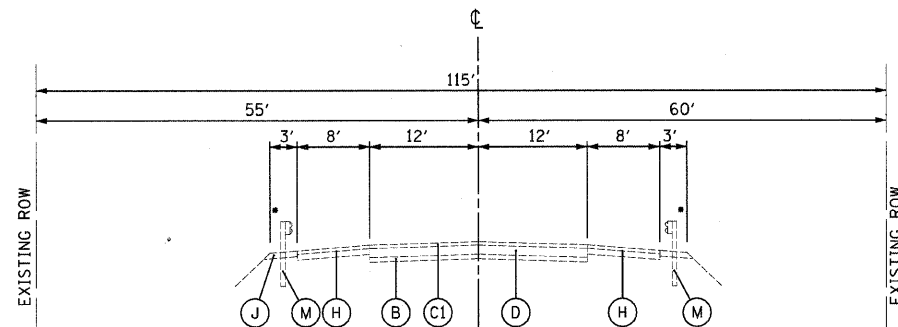

EXISTING
TYPICAL SECTION
MANHATTAN-MONEE ROAD
③ STA. 14027+15 TO STA. 14030+00

• GUARDRAIL IS NOT PRESENT IN ALL LOCATIONS

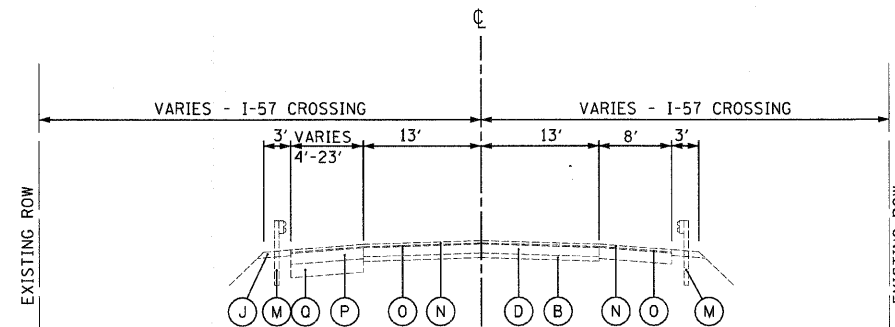

EXISTING
TYPICAL SECTION
MANHATTAN-MONEE ROAD
⑥ STA. 14038+56 TO STA. 14042+40

EXISTING LEGEND:

- Ⓐ EXISTING SUB-BASE GRANULAR MATERIAL, TYPE C, 4" AND VARIES
- Ⓑ EXISTING STABILIZED SUB-BASE, 4" AND VARIES
- Ⓒ EXISTING HOT-MIX ASPHALT PAVEMENT, 3" AND VARIES
- Ⓒ2 EXISTING HOT-MIX ASPHALT PAVEMENT, 3 1/4" AND VARIES
- Ⓓ EXISTING PORTLAND CEMENT CONCRETE PAVEMENT, 8" AND VARIES
- Ⓔ EXISTING CONTINUOUSLY REINFORCED PORTLAND CEMENT CONCRETE PAVEMENT, 8" AND VARIES
- Ⓕ EXISTING AGGREGATE SHOULDERS
- Ⓖ EXISTING HOT-MIX ASPHALT SHOULDER, 8" AND VARIES
- Ⓕ EXISTING HOT-MIX ASPHALT SHOULDER, 10" AND VARIES (WHEN NO GUARDRAIL IS PRESENT - HOT-MIX ASPHALT, 3" - AGGREGATE BASE, 5" AND VARIES)
- Ⓖ EXISTING HOT-MIX ASPHALT SHOULDER, 10" AND VARIES
- Ⓖ EXISTING HOT-MIX ASPHALT STABILIZATION, 6" AND VARIES (WHEN GUARDRAIL IS PRESENT)
- Ⓖ EXISTING STABILIZED SHOULDER, 8" AND VARIES
- Ⓖ EXISTING STABILIZED SHOULDER, 11" AND VARIES
- Ⓖ EXISTING COMBINATION CONCRETE CURB AND GUTTER
- Ⓖ EXISTING STEEL PLATE BEAM GUARDRAIL
- Ⓖ EXISTING POLYMERIZED HOT-MIX ASPHALT SURFACE COURSE, MIX "F", N90, 1 3/4"
- Ⓖ EXISTING POLYMERIZED LEVELING BINDER (MACHINE METHOD), IL-4.75, N50, 3/4"
- Ⓖ EXISTING HOT-MIX ASPHALT BINDER COURSE, IL-19.0, N90, 8 1/2"
- Ⓖ EXISTING AGGREGATE SUBGRADE, 12 "
- Ⓖ EXISTING PCES, 24 "
- Ⓖ EXISTING PIPE UNDERDRAINS, 4"

NOTES:

- 1.) EXISTING PAVEMENT THICKNESSES ARE ESTIMATES OBTAINED FROM EXISTING PLANS AND PAVEMENT CORES AND MAY VARY FROM DIMENSIONS SHOWN.
- 2.) EXISTING PAVEMENT WIDTHS SHOWN ARE NOMINAL AND MAY VARY SLIGHTLY FROM THE DIMENSIONS INDICATED.
- 3.) STATIONING LIMITS SHOWN HERE ARE APPROXIMATE.

REVISIONS	
NAME	DATE

ILLINOIS DEPARTMENT OF TRANSPORTATION
I-57 AT MANHATTAN - MONEE ROAD

EXISTING TYPICAL SECTIONS
MANHATTAN - MONEE ROAD

SCALE: VERT. NTS
DATE 9/19/2008

DRAWN BY ML, BDC, NS
CHECKED BY TMW

Clark Dietz
ENGINEERS

DESIGN FIRM REGISTRATION
No. 184-000450
118 SOUTH CLINTON STREET
SUITE 600
CHICAGO, IL 60661
PHONE : 312.648.9900
FAX : 312.648.0204