

SHEET INDEX

1. COVER SHEET
2. SUMMARY OF QUANTITIES & GENERAL NOTES
- 3.-5. LIGHTING PLAN SHEETS
6. LIGHTING WIRING DIAGRAM
7. LIGHTING CONTROL CABINET
- 8.-9. LIGHTING DETAILS

TRAFFIC DATA

IL RTE 19: 2007 ADT = 22,200
POSTED SPEED LIMIT = 45 MPH

IL RTE 59: 2007 ADT = 46,100
POSTED SPEED LIMIT = 45 MPH

STATE STANDARDS

000001-05 STANDARD SYMBOLS, ABBREVIATIONS AND PATTERNS
701501-04 URBAN LANE CLOSURE, 2L, 2W, UNDIVIDED
701606-05 URBAN LANE CLOSURE, MULTILANE, 2W WITH MOUNTABLE MEDIAN
701701-05 URBAN LANE CLOSURE, MULTILANE INTERSECTION
701901 - TRAFFIC CONTROL DEVICES
878001-06 CONCRETE FOUNDATION DETAILS

STATE OF ILLINOIS DEPARTMENT OF TRANSPORTATION DIVISION OF HIGHWAYS PLANS FOR PROPOSED FEDERAL AID HIGHWAY

**F.A.U. ROUTE 1321: IL RTE 19 (IRVING PARK RD)
west of IL RTE 59 (SUTTON RD) TO east of MADISON DR
SECTION NO: 05-00049-00-LT
ROADWAY LIGHTING IMPROVEMENTS
VILLAGE OF STREAMWOOD
COOK COUNTY
JOB NO. C-91-197-08
PROJECT NO. M-8003(943)**

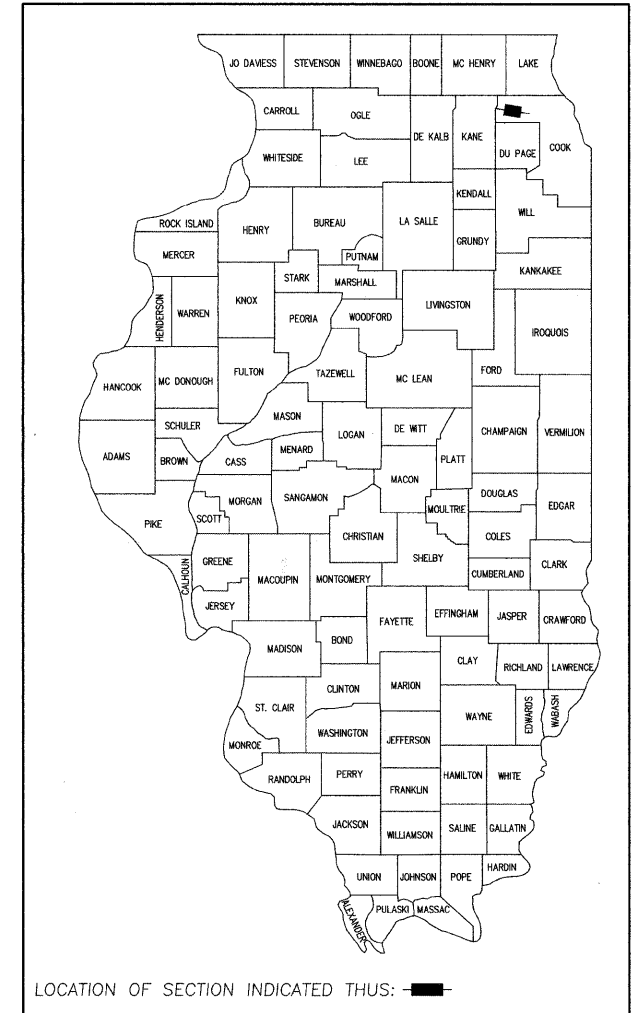

LOCATION MAP

(NOT TO SCALE)

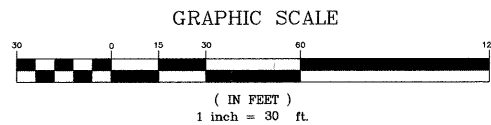

NOTE: CONSTRUCTION MEANS, METHODS AND JOB SITE SAFETY IS THE COMPLETE RESPONSIBILITY OF THE CONTRACTOR.

EXISTING UTILITIES: WHEN THE PLANS OR SPECIAL PROVISIONS INCLUDE INFORMATION PERTAINING TO THE LOCATION OF UNDERGROUND UTILITY FACILITIES, SUCH INFORMATION REPRESENTS ONLY THE OPINION OF THE ENGINEER AS TO THE LOCATION OF SUCH UTILITIES AND IS ONLY INCLUDED FOR THE CONVENIENCE OF THE BIDDER. THE ENGINEER AND OWNER ASSUME NO RESPONSIBILITY WHATEVER IN RESPECT TO THE SUFFICIENCY OR ACCURACY OF THE INFORMATION SHOWN ON THE PLANS RELATIVE TO THE LOCATION OF UNDERGROUND UTILITY FACILITIES OR THE MANNER IN WHICH THEY ARE TO BE REMOVED OR ADJUSTED. IT SHALL BE THE CONTRACTOR'S RESPONSIBILITY TO DETERMINE THE ACTUAL LOCATION OF ALL SUCH FACILITIES. HE SHALL ALSO OBTAIN FROM THE RESPECTIVE UTILITY COMPANIES, DETAILED INFORMATION RELATIVE TO THE LOCATION OF THEIR FACILITIES AND THE WORKING SCHEDULES OF THE UTILITY COMPANIES FOR REMOVING OR ADJUSTING THEM.

CONTRACTOR IS RESPONSIBLE FOR CONTACTING J.U.L.I.E. AT 1-800-892-0123 AND MUST ACQUIRE A DIG NUMBER A MINIMUM OF 72 HOURS PRIOR TO ANY WORK BEING DONE.

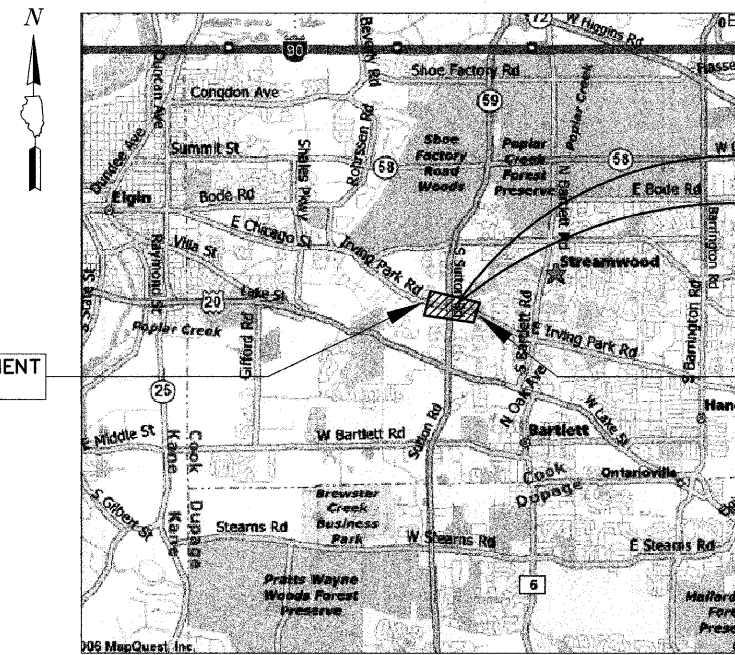

BEGIN IMPROVEMENT
STA. 176+45

PROJECT LOCATION

F.A.U. ROUTE 1321: IL RTE 19 (IRVING PARK RD)
VILLAGE OF STREAMWOOD, ILLINOIS

END IMPROVEMENT
STA. 198+00

GROSS & NET LENGTH OF PROJECT = 2,155 FEET = 0.41 MILES

STATE OF ILLINOIS DEPARTMENT OF TRANSPORTATION DIVISION OF HIGHWAYS
APPROVED: <u>JULY 24</u> 20 <u>08</u> <i>Mark Man, P.E.</i> VILLAGE OF STREAMWOOD DIRECTOR OF PUBLIC WORKS
APPROVED: <u>JULY 23</u> 20 <u>08</u> <i>Chris Christopher Holt</i> DISTRICT ENGINEER OF LOCAL ROADS & STREETS
RELEASING FOR BID BASED ON LIMITED REVIEW <u>JULY 25</u> 20 <u>08</u> <i>Diana M. O'Keefe</i> DEPUTY DIRECTOR OF HIGHWAYS, REGION 1 ENGINEER

GEWALT HAMILTON
ASSOCIATES, INC.

Consulting Engineers & Surveyors

850 Forest Edge Drive
Vernon Hills, IL 60061
847-478-9700



SIGNED: Bruce L. Shrade P.E.
DATE: July 23, 20 08
ILLINOIS LICENSE NO.: 62-39905
EXPIRATION DATE: November 30, 20 08

CONTRACT NO. 63068

PRINTED BY THE AUTHORITY OF THE STATE OF ILLINOIS

F.A.U. R.T.E.	SECTION	COUNTY	TOTAL SHEETS	SHEET NO.
1321	05-00049-00-LT	COOK	9	2
SUMM. OF QUANTITIES & GEN. NOTES				
ILLINOIS				

CONTRACT NO. 63068

GENERAL NOTES

- A-1. BEFORE STARTING ANY EXCAVATION, THE CONTRACTOR SHALL CALL "JULIE" AT 800-892-0123 FOR FIELD LOCATIONS OR BURIED ELECTRIC, TELEPHONE AND GAS FACILITIES (48 HOUR NOTIFICATION IS REQUIRED).
- A-2. THE CONTRACTOR SHALL COORDINATE CONSTRUCTION ACTIVITIES WITH UTILITY COMPANIES AND THE VILLAGE OF STREAMWOOD.
- A-3. THE CONTRACTOR WILL NOT BE ALLOWED TO SET UP A YARD OR FIELD OFFICE ON STATE PROPERTY WITHOUT WRITTEN PERMISSION FROM THE DEPARTMENT.
- A-4. BARRICADES: THE CONTRACTOR SHALL PROVIDE AND INSTALL TWO (2) WEIGHTED SANDBAGS ON EACH TYPE I OR TYPE II BARRICADE USED--ONE (1) WEIGHTED SANDBAG ACROSS EACH BOTTOM RAIL.
- A-5. TYPE II BARRICADES WHEN USED FOR APPROACH TAPERS, AS INDICATED ON THE STATE STANDARDS OR SHOWN ON THE PLANS SHALL BE SAFETYCADE DIRECTION INDICATOR BARRICADES MANUFACTURED BY WJ INDUSTRIES, INC. 880 N. ADDISON, P.O. BOX 7050, VILLA PARK, IL 60181-7050 OR EQUIVALENT. THE CONTRACTORS BID PRICES FOR TRAFFIC CONTROL ITEMS SHALL INCLUDE THE COST OF THESE BARRICADES.
- A-6. THE LOCAL ROADS PROJECT ENGINEER FOR THESE IMPROVEMENTS IS PHIL MARCYN AT 847-705-4189.

LIGHTING NOTES

- B-1. THE VILLAGE OF STREAMWOOD SHALL BE RESPONSIBLE FOR THE PROVISION OF CONSTRUCTION FUNDING, OWNERSHIP, ELECTRICAL ENERGY AND MAINTENANCE DURING AND AFTER CONSTRUCTION.
- B-2. IT SHALL BE THE CONTRACTOR'S RESPONSIBILITY TO MARK THE PROPOSED LOCATIONS OF ALL LIGHT POLES AND THE LIGHTING CONTROLLER FOR EXAMINATION AND CONFIRMATION WITH THE ENGINEER AT THE PRECONSTRUCTION INSPECTION. THE EXACT LOCATIONS OF ALL ITEMS SHALL BE CONFIRMED WITH THE ENGINEER PRIOR TO STARTING WORK.
- B-3. THE CONTRACTOR SHALL MAKE SPECIAL NOTE OF THE REQUIREMENTS FOR GROUNDING. GROUNDING CONNECTIONS AT THE FOUNDATION SHALL BE EXOTHERMICALLY WELDED, AS SPECIFIED, AND SHALL BE INSPECTED AND APPROVED BY THE RESIDENT ENGINEER PRIOR TO POURING CONCRETE OR BACKFILLING, AS APPLICABLE.
- B-4. THE CONTRACTOR SHALL BE RESPONSIBLE FOR THE ESTABLISHMENT OF FINISHED GRADE. THE ENGINEER MAY ASSIST THE CONTRACTOR AS APPLICABLE, BUT THE RESPONSIBILITY FOR COORDINATING FINISHED GRADE ELEVATION WITH THE TOP OF THE FOUNDATION HEIGHTS SHALL REMAIN WITH THE CONTRACTOR.
- B-5. ALL LIGHT POLES SHALL BE LOCATED WITHIN THE CORRECT SET BACK IDOT REQUIREMENTS FROM THE BACK OF CURB TO THE FACE OF THE PROPOSED LIGHT POLE.
- B-6. NO POLES SHALL BE ERECTED UNTIL THE RESPECTIVE FOUNDATIONS HAVE CURED, AS APPROVED BY THE ENGINEER.
- B-7. POLES WITH MAST ARMS SHALL NOT BE ERECTED AND LEFT TO STAND WITHOUT LUMINAIRES, TO MAINTAIN THE STRUCTURAL INTEGRITY OF POLES. NOTE THAT THE PROPOSED LIGHT POLES WILL NOT BE CONSIDERED COMPLETE WITHOUT THE LUMINAIRES INSTALLED.
- B-8. UNLESS OTHERWISE NOTED, ALL CONDUIT PROVIDED BY THIS CONTRACT SHALL BE 2" GALVANIZED STEEL CONDUIT CONFORMING TO IDOT STANDARD SPECIFICATIONS FOR ROAD AND BRIDGE CONSTRUCTION SECTION 1088.01 (c).
- B-9. UNLESS OTHERWISE NOTED, ALL CONVENTIONAL POLES SHALL BE FRANGIBLE WITH BREAKAWAY DEVICES AS SPECIFIED.
- B-10. THE CONTRACTOR SHALL MAKE NOTE OF THE SPECIAL CONTROL CABINET, AUXILIARY CABINET AND LIGHTING UNIT IDENTIFICATION REQUIREMENTS NOTED ON THE DRAWINGS.
- B-11. ALL WIRING SHALL BE IN ACCORDANCE WITH THE REQUIREMENTS OF THE NATIONAL ELECTRICAL CODE. PARTICULAR ATTENTION IS DIRECTED TO THE REQUIREMENTS FOR ELECTRIC SERVICE, GROUNDING, AND OVERCURRENT PROTECTION.
- B-12. THE ELECTRICAL SUPPLY SHALL BE A PROPERLY GROUNDED AC SYSTEM. DC SERIES WIRING WILL NOT BE PERMITTED.
- B-13. THE AC SYSTEM SHALL BE PROPERLY GROUNDED AT THE ASSOCIATED SERVICE DISCONNECTING MEANS. AN EQUIPMENT GROUNDING CONDUCTOR SHALL BE EXTENDED CONTINUOUS WITH ALL CIRCUIT WIRING AND SHALL BE BONDED TO THE SYSTEM GROUND AT THE SERVICE DISCONNECTING MEANS. IT IS RECOMMENDED THAT THE EQUIPMENT GROUNDING CONDUCTOR BE INSULATED. THE EQUIPMENT GROUNDING CONDUCTOR SHALL BE IN INTEGRAL PART OF ANY MULTI-CONDUCTOR CABLE OR SHALL BE RUN WITH THE CIRCUIT CONDUCTORS IN THE SAME RACEWAY. A SEPARATE GROUNDING CONDUCTOR WILL NOT BE PERMITTED. THE EQUIPMENT GROUNDING CONDUCTOR SHALL BE SPLICED AND BONDED VIA A PITGAIL CONNECTION AT EACH POLE.
- B-14. ALL CONDUCTORS AND EQUIPMENT SHALL HAVE PROPER OVERCURRENT PROTECTION. OVERCURRENT PROTECTION SHALL BE PROVIDED FOR EACH LUMINAIRE AND ITS ASSOCIATED BRANCH CIRCUIT EITHER BY THE USE OF INDIVIDUAL POLE BASE FUSING, FUSING WITHIN THE LUMINAIRE, OR OTHER MEANS AS APPROVED BY THE ENGINEER.
- B-15. THE ANCHOR BOLTS SHALL BE PROPERLY SECURED IN PLACE BEFORE THE CONCRETE IS PLACED IN THE FORMS.
- B-16. EXCAVATION FOR THE POLE FOUNDATION SHALL BE MADE WITH AN AUGER, 24 INCHES IN DIAMETER.
- B-17. ALL WORK SHALL CONFORM TO THE NATIONAL ELECTRICAL CODE. THE LATEST EDITION OF THE ILLINOIS DEPT. OF TRANSPORTATION STANDARD SPECIFICATIONS FOR ROAD AND BRIDGE CONSTRUCTION AND ANY APPLICABLE LOCAL CODES.
- B-18. BEFORE INSTALLING LIGHT STANDARDS NEAR OVERHEAD UTILITIES CALL LOCAL UTILITY FOR LOCATION APPROVAL.
- B-19. LOCATION OF CONTROLLER CABINET SHALL BE VERIFIED IN THE FIELD BY THE ENGINEER BEFORE FOUNDATION IS EXCAVATED OR POURED.
- B-20. NO MATERIALS SHALL BE DELIVERED TO THE JOB SITE UNTIL ALL PERTINENT EQUIPMENT SUBMITTALS HAVE BEEN APPROVED BY THE ENGINEER.
- B-21. CONTRACTOR TO COORDINATE ALL SERVICE CONNECTIONS WITH LOCAL UTILITY COMPANY. CONTRACTOR SHALL PROVIDE THE PAD FOR TRANSFORMER PER LOCAL UTILITY REQUIREMENTS AND COIL SUFFICIENT CABLES AT TRANSFORMER FOR UTILITY CONNECTION.
- B-22. UPON COMPLETION OF THE PERMANENT LIGHTING SYSTEM THE CONTRACTOR SHALL REQUEST IN WRITING A REQUEST FOR PREFINAL INSPECTION A MINIMUM OF THREE DAYS NOTICE TO THE VILLAGE OF STREAMWOOD.
- B-23. ALL PAY ITEMS REFER TO THE IDOT STANDARDS FOR ROAD AND BRIDGE CONSTRUCTION LATEST EDITION, UNLESS OTHERWISE NOTED.

SUMMARY OF QUANTITIES Y030-1E				
NO.	CODE NO.	PAY ITEM	UNIT	TOTAL
1.	67100100	MOBILIZATION	L SUM	1
2.	70102620	TRAFFIC CONTROL AND PROTECTION, STANDARD 701501	L SUM	1
2.	70102625	TRAFFIC CONTROL AND PROTECTION, STANDARD 701606	L SUM	1
3.	70102635	TRAFFIC CONTROL AND PROTECTION, STANDARD 701701	L SUM	1
	70102640	TRAFFIC CONTROL AND PROTECTION, STANDARD 701801	L SUM	1
4.	80400100	ELECTRIC SERVICE INSTALLATION	EACH	1
5.	80400200	ELECTRIC UTILITY SERVICE CONNECTION	LSUM	1
6.	81000600	CONDUIT IN TRENCH, 2" DIA., GALVANIZED STEEL	FOOT	584
7.	81018500	CONDUIT PUSHED, 2" DIA., GALVANIZED STEEL	FOOT	1,064
8.	81900200	TRENCH AND BACKFILL FOR ELECTRICAL WORK	FOOT	584
9.	82500505	LIGHTING CONTROLLER, SPECIAL	EACH	1
10.	83600200	LIGHT POLE FOUNDATION, 24" DIAMETER	FOOT	625
11.	84200500	REMOVAL OF EXISTING LIGHTING UNIT, SALVAGE	EACH	1
12.	87800215	CONCRETE FOUNDATION, TYPE D	EACH	1
13.	XX007584	CONDUIT, BORED AND PULLED, GALVANIZED STEEL, 2", SPECIAL	FOOT	3,956
14.	XX007585	ELECTRIC CABLE IN CONDUIT, 600V, (XLP-TYPE USE) 2/C NO. 8 & 1/C NO. 6 GROUND, SPECIAL	FOOT	934
15.	XX007586	ELECTRIC CABLE IN CONDUIT, 600V, (XLP-TYPE USE) 4/C NO. 6 & 1/C NO. 6 GROUND, SPECIAL	FOOT	4,820
16.	XX007587	LIGHT POLE, ALUMINUM, 32 FT. M.H., 4 FT. MAST ARM, WITH 250W HPS LUMINAIRE, SPECIAL	EACH	50
17.	XX007588	LIGHT POLE, ALUMINUM, 32 FT. M.H., DUAL 4 FT. MAST ARMS, WITH TWO 250W HPS LUMINAIRES, SPECIAL	EACH	1
18.	XX007589	LIGHT POLE, ALUMINUM, 32 FT. M.H., DUAL 4 FT. MAST ARMS, WITH TWO 400W HPS LUMINAIRES, SPECIAL	EACH	4

PLANS PREPARED BY:
GEWALT HAMILTON
 ASSOCIATES, INC.
 Consulting Engineers & Surveyors
 850 Forest Ridge Drive
 Verdon Hills, IL 60051
 (847) 478-9700
 (847) 478-9701 Fax

REVISIONS	
NAME	DATE

ILLINOIS DEPARTMENT OF TRANSPORTATION
SUMMARY OF QUANTITIES & GENERAL NOTES
 IRVING PARK ROAD LIGHTING
 STREAMWOOD, ILLINOIS

SCALE: 1"=30'
 DATE: 6-16-08

DRAWN BY: DRS
 DESIGNED BY: AJP
 CHECKED BY: BLS

F.A.U. R.T.E.	SECTION	COUNTY	TOTAL SHEETS	SHEET NO.
1321	05-00049-00-LT	COOK	9	3
LIGHTING PLAN (1 OF 3)				
ILLINOIS				

CONTRACT NO. 63068

NOTE: ALL 2" PUSHED RIGID GALVANIZED STEEL CONDUIT SHALL EXTEND 2 FEET BEYOND BACK OF CURB OR EDGE OF PAVED SURFACE.

POLE PLACEMENT IL RTE 59 (SUTTON ROAD)			
STATION	CIRCUIT	POLE LABEL	SETBACK*
138+82	H	SH1	6.0'
138+84	G	SG5	5.3'
141+20	E	SE4	6.3'
141+21	F	SF1	6.3'

*BACK OF CURB TO FACE OF POLE BASE

POLE PLACEMENT IL RTE 19 (IRVING PARK ROAD)			
STATION	CIRCUIT	POLE LABEL	SETBACK*
176+58	H	SH6	5.3'
177+58	E	SE6	5.3'
177+61	G	SG7	5.3'
178+58	F	SF6	5.3'
178+62	H	SH5	4.7'
179+56	E	SE5	5.3'
179+66	G	SG6	4.7'
179+93	F	SF5	6.2'
180+38	H	SH4	8.4'
181+30	E	SE1	4.3'
181+67	G	SG1	12.5'
182+02	A	SA8	5.3'
182+04	D	SD7	5.3'
183+21	B	SB8	5.3'
183+24	C	SC7	5.3'

*BACK OF CURB TO FACE OF POLE BASE

LEGEND

- PROPOSED LIGHT POLE
250W HPS LUMINAIRE
240V, 1 PHASE, 2 WIRE
32 FT., 4 FT MAST ARM
SETBACK 6' FROM BACK OF CURB (typical)
SEE FOUNDATION DETAIL - SHEET 8
- PROPOSED LIGHT POLE
(2) 400W HPS LUMINAIRE
240V, 1 PHASE, 2 WIRE
32 FT., 4 FT MAST ARM
SETBACK 6' FROM BACK OF CURB (typical)
SEE FOUNDATION DETAIL - SHEET 8
- PROPOSED CONTROLLER CABINET
REFER TO SHEET 7
- PROPOSED LIGHT POLE LABEL
- POLE NUMBER ON GIVEN CIRCUIT
LETTER - CIRCUIT DESIGNATION (A-H)
LETTER - CONTROLLER DESIGNATION (S)

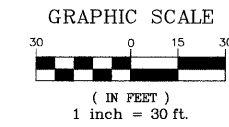
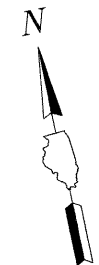

START OF PROJECT
STA: 176+45

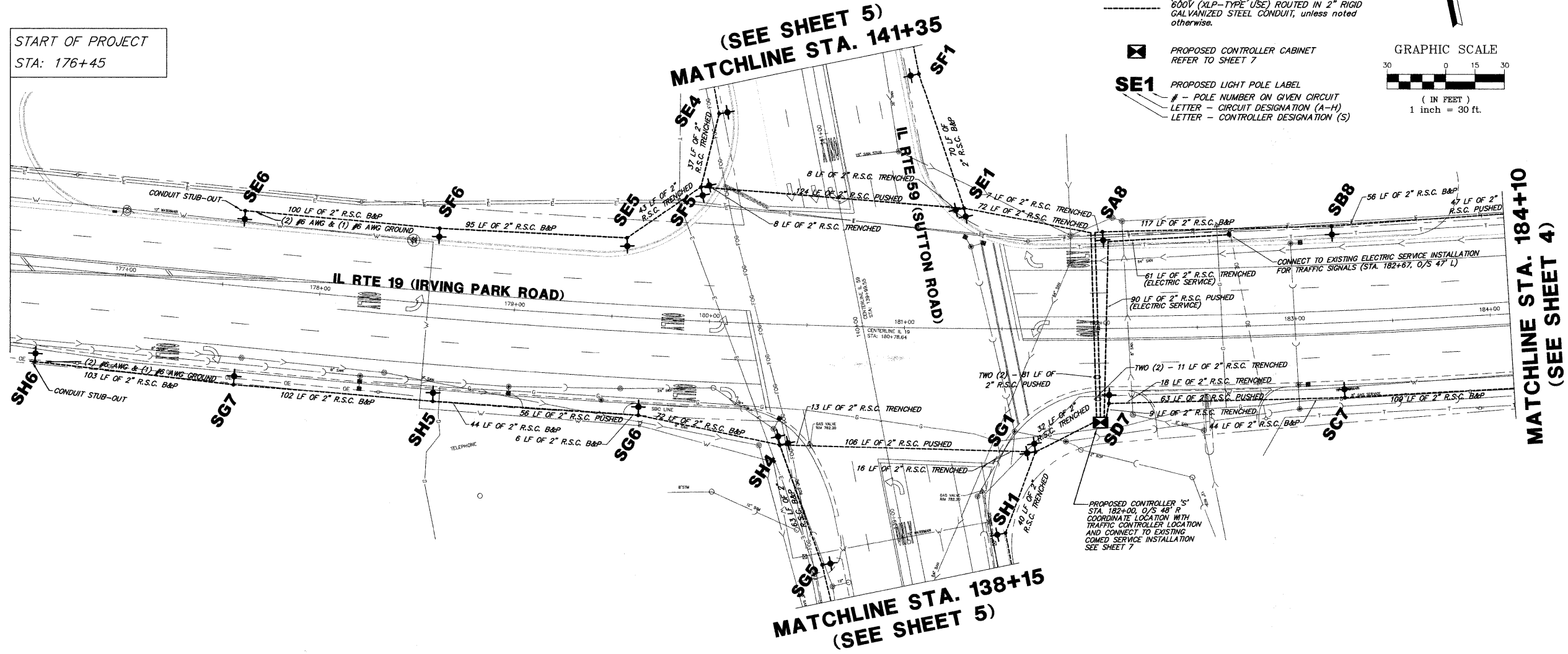

PLANS PREPARED BY:
GEWALT HAMILTON ASSOCIATES, INC.
Consulting Engineers & Surveyors
850 Forest Edge Drive
Vernon Hills, IL 60061
(847) 476-9700
(847) 476-9701 Fax

REVISIONS	
NAME	DATE

ILLINOIS DEPARTMENT OF TRANSPORTATION
LIGHTING PLAN (1 OF 3)

**IRVING PARK ROAD LIGHTING
STREAMWOOD, ILLINOIS**

SCALE: 1"=30'
DATE: 6-16-08

DRAWN BY: DRS
DESIGNED BY: AJP
CHECKED BY: BLS

LIGHTING PLAN (2 OF 3)

MATCHLINE STA. 184+10
(SEE SHEET 3)

MATCHLINE STA 192+90
(SEE BELOW)

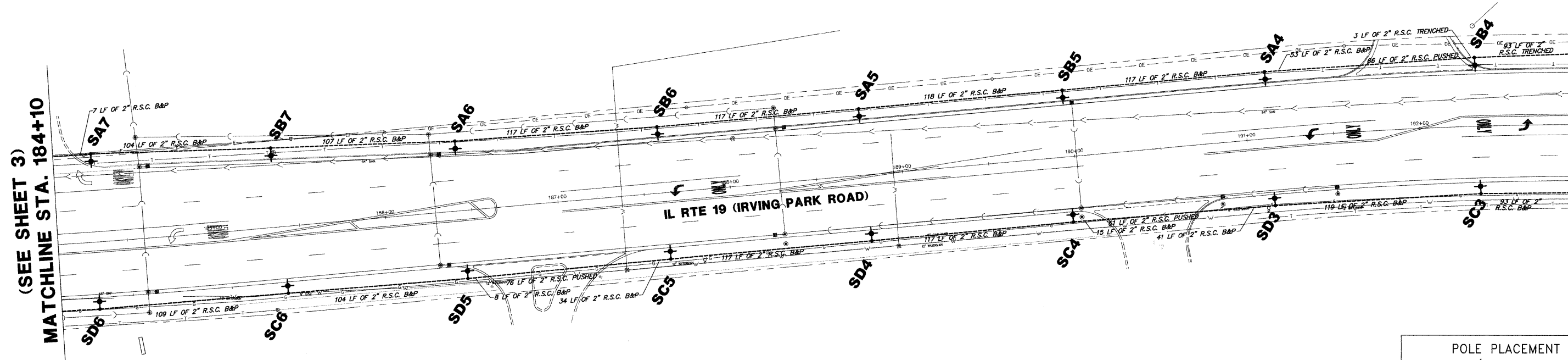

LEGEND

- PROPOSED LIGHT POLE
 250W HPS LUMINAIRE
 240V, 1 PHASE, 2 WIRE
 32 FT., 4 FT MAST ARM
 SETBACK 6' FROM BACK OF CURB (typical)
 SEE FOUNDATION DETAIL - SHEET 8
- PROPOSED LIGHT POLE
 (2) 250W HPS LUMINAIRE
 240V, 1 PHASE, 2 WIRE
 32 FT., 4 FT MAST ARM
 SETBACK 6' FROM BACK OF CURB (typical)
 SEE FOUNDATION DETAIL - SHEET 8
- (4) #6 AWG & (1) #6 AWG GROUND
 600V (XLP-TYPE USE) ROUTED IN 2" RIGID
 GALVANIZED STEEL CONDUIT, unless noted
 otherwise.
- SB2 PROPOSED LIGHT POLE LABEL
 # - POLE NUMBER ON GIVEN CIRCUIT
 LETTER - CIRCUIT DESIGNATION (A-H)
 LETTER - CONTROLLER DESIGNATION (S)

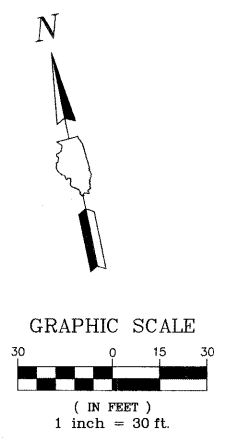

MATCHLINE STA. 192+90
(SEE ABOVE)

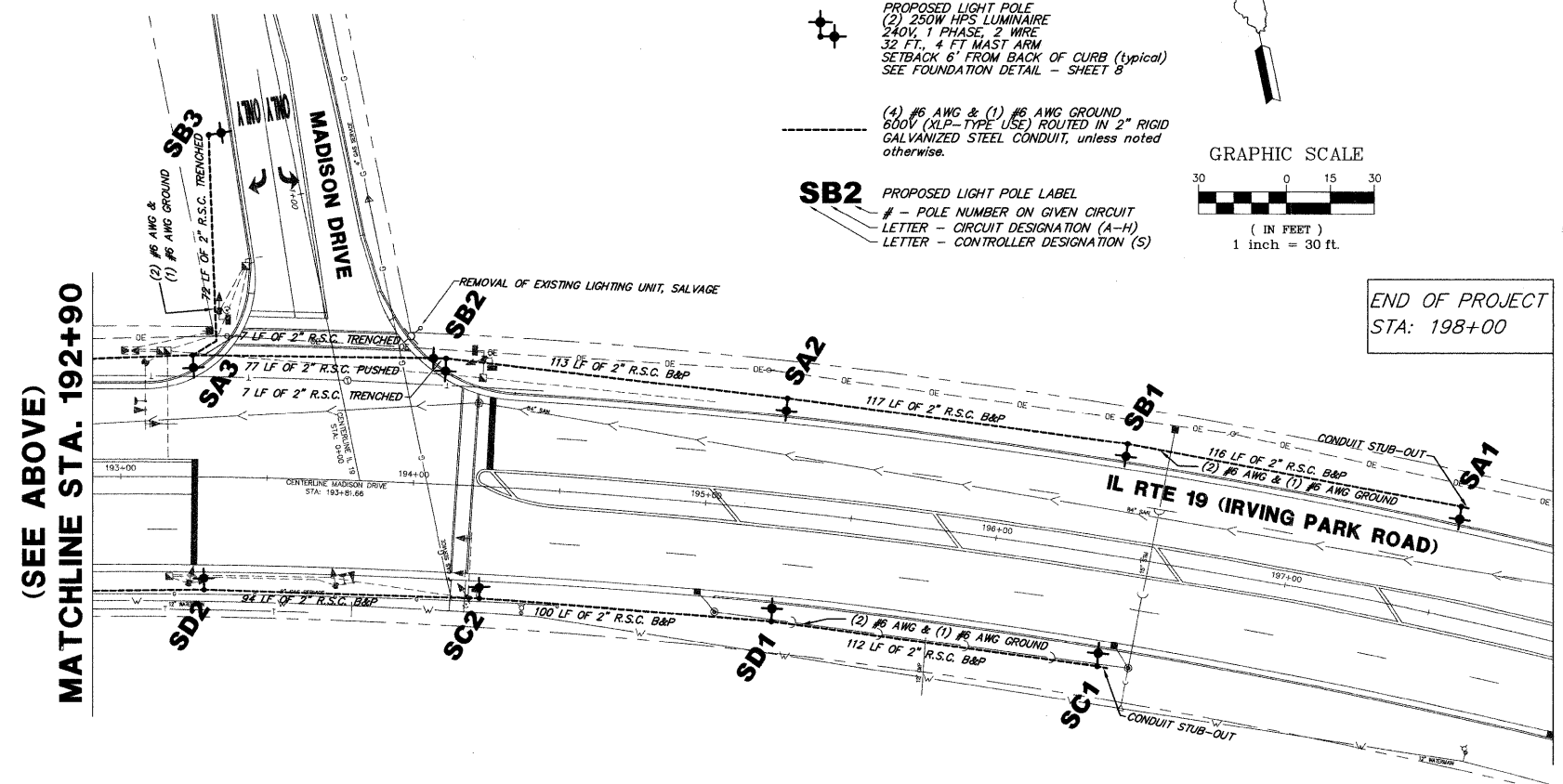

END OF PROJECT
STA: 198+00

NOTE: ALL 2" PUSHED RIGID GALVANIZED STEEL CONDUIT SHALL EXTEND 2 FEET BEYOND BACK OF CURB OR EDGE OF PAVED SURFACE.

STATION	CIRCUIT	POLE LABEL	SETBACK*
001+26	B	SB3	6.6'

*BACK OF CURB TO FACE OF POLE BASE

**POLE PLACEMENT
IL RTE 19 (IRVING PARK ROAD)**

STATION	CIRCUIT	POLE LABEL	SETBACK*
184+32	D	SD6	5.3'
184+33	A	SA7	5.3'
185+37	B	SB7	5.3'
185+40	K	SC6	5.3'
186+44	A	SA6	5.3'
186+44	D	SD5	5.3'
187+61	B	SB6	5.3'
187+62	C	SC5	5.3'
188+78	A	SA5	5.3'
188+79	D	SD4	5.3'
189+96	C	SC4	4.7'
189+96	B	SB5	5.3'
191+13	D	SD3	5.3'
191+14	A	SA4	5.3'
192+33	B	SB4	6.2'
192+34	C	SC3	5.3'
193+24	A	SA3	4.2'
193+29	D	SD2	5.3'
194+09	B	SB2	3.4'
194+25	C	SC2	5.3'
195+24	A	SA2	5.3'
195+27	D	SD1	5.3'
196+39	B	SB1	5.3'
196+41	C	SC1	5.3'
197+53	A	SA1	5.3'

*BACK OF CURB TO FACE OF POLE BASE

PLANS PREPARED BY:
GEWALT HAMILTON
ASSOCIATES, INC.
Consulting Engineers & Surveyors
650 Forest Edge Drive
Vernon Hills, IL 60061
(847) 476-9700
(847) 476-9701 Fax

REVISIONS	
NAME	DATE

ILLINOIS DEPARTMENT OF TRANSPORTATION
LIGHTING PLAN (2 OF 3)

**IRVING PARK ROAD LIGHTING
STREAMWOOD, ILLINOIS**

SCALE: 1"=30'
DATE: 6-16-08

DRAWN BY: DRS
DESIGNED BY: AJP
CHECKED BY: BLS

F.A.U. R.T.E.	SECTION	COUNTY	TOTAL SHEETS	SHEET NO.
1321	05-00049-00-LT	COOK	9	5
LIGHTING PLAN (3 OF 3)				
ILLINOIS				

CONTRACT NO. 63068

END OF PROJECT
STA: 144+10

START OF PROJECT
STA: 135+85

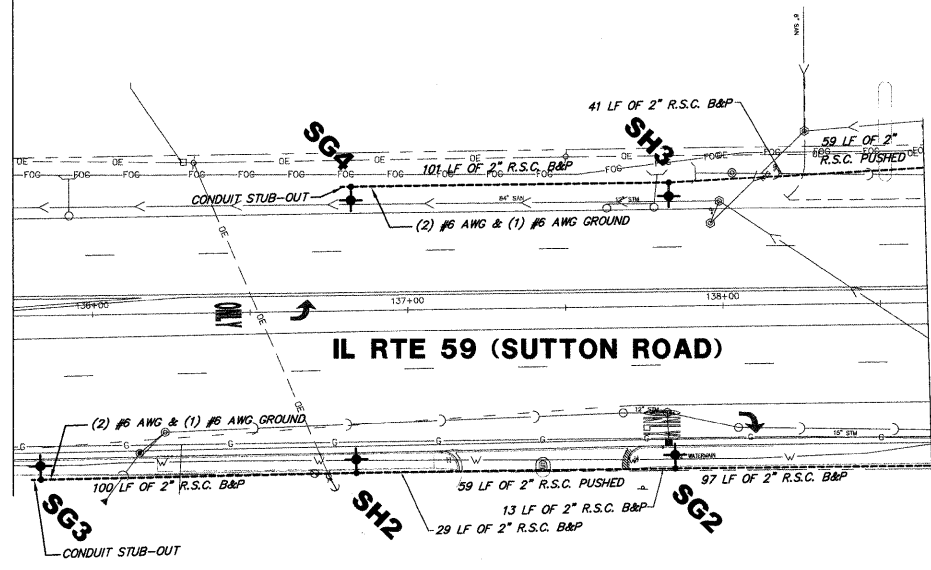

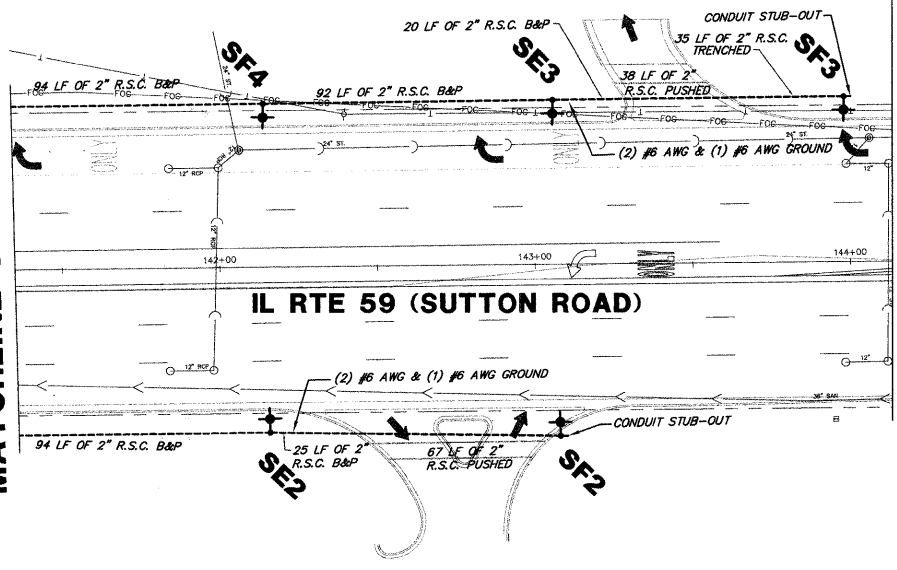

MATCHLINE STA. 138+15
(SEE SHEET 3)

MATCHLINE STA. 141+35
(SEE SHEET 3)



LEGEND

- 
 PROPOSED LIGHT POLE
 250W HPS LUMINAIRE
 240V, 1 PHASE, 2 WIRE
 32 FT., 4 FT MAST ARM
 SETBACK 6' FROM BACK OF CURB (typical)
 SEE FOUNDATION DETAIL - SHEET 8
- 
 PROPOSED LIGHT POLE
 (2) 250W HPS LUMINAIRE
 240V, 1 PHASE, 2 WIRE
 32 FT., 4 FT MAST ARM
 SETBACK 6' FROM BACK OF CURB (typical)
 SEE FOUNDATION DETAIL - SHEET 8
- 
 (4) #6 AWG & (1) #6 AWG GROUND
 600V (XLP-TYPE USE) ROUTED IN 2" RIGID GALVANIZED STEEL CONDUIT, unless noted otherwise.
- SB2** PROPOSED LIGHT POLE LABEL
 # - POLE NUMBER ON GIVEN CIRCUIT
 LETTER - CIRCUIT DESIGNATION (A-H)
 LETTER - CONTROLLER DESIGNATION (S)

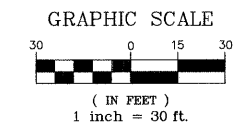
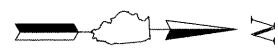

NOTE: ALL 2" PUSHED RIGID GALVANIZED STEEL CONDUIT SHALL EXTEND 2 FEET BEYOND BACK OF CURB OR EDGE OF PAVED SURFACE.

POLE PLACEMENT IL RTE 59 (SUTTON ROAD)			
STATION	CIRCUIT	POLE LABEL	SETBACK*
135+83	G	SG3	5.3'
136+83	G	SG4	5.3'
136+83	H	SH2	5.3'
137+83	H	SH3	5.3'
137+84	G	SG2	6.0'
142+14	F	SF4	6.3'
142+15	E	SE2	6.3'
143+06	E	SE3	6.3'
143+08	F	SF2	7.8'
143+98	F	SF3	6.3'

*BACK OF CURB TO FACE OF POLE BASE

PLANS PREPARED BY:
GEWALT HAMILTON
ASSOCIATES, INC.
Consulting Engineers & Surveyors
850 Forest Edge Drive
Verona Hills, IL 60061
(847) 478-9700
(847) 478-9701 Fax

REVISIONS	
NAME	DATE

ILLINOIS DEPARTMENT OF TRANSPORTATION
LIGHTING PLAN (3 OF 3)

**IRVING PARK ROAD LIGHTING
STREAMWOOD, ILLINOIS**

SCALE: 1"=30'
DATE: 6-16-08

DRAWN BY: DRS
DESIGNED BY: AJP
CHECKED BY: BLS

CONTRACT NO. 63068

LOAD TABULATION AND VOLTAGE DROP FOR LIGHTING CONTROLLER "S"

CIRCUIT	WATTS	AMPS	VOLTAGE DROP AT LAST POLE
A	2840	11.8	4.50%
B	3195	11.8	4.76%
C	2485	10.4	3.44%
D	2485	10.4	2.97%
E	2865	11.9	1.43% @ SE6
F	2865	11.9	1.51% @ SF3
G	3120	11.9	0.95% @ SG7
H	2865	11.9	1.00% @ SH6

MAX ALLOWABLE @ BALLAST IS 10% VOLTS DROP

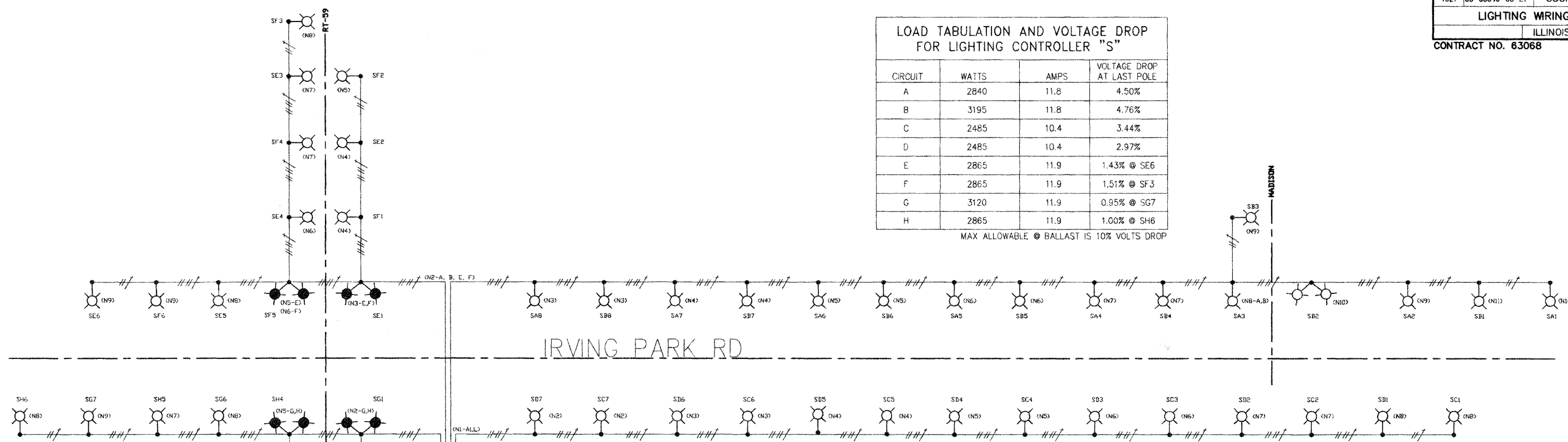

200A/2P, 240/120 VOLT, SINGLE PHASE SERVICE FROM EXISTING COMED SERVICE. INSTALLATION FOR INTERSECTION TRAFFIC SIGNALS. 3/4" x 1/2" RIGID GALVANIZED STEEL C-BOND TO GROUNDING ELECTRODE WITH #2 AWG COPPER CONDUCTOR. REFER TO FOUNDATION TYPE 3 PER STATE STANDARD 078001 - CONCRETE FOUNDATION DETAILS FOR ELECTRODE LOCATION.

1 WIRING DIAGRAM
NO SCALE

LEGEND

- SINGLE 250W H.P.S. LUMINAIRE, 240V, 1 PHASE, 2 WIRE
- DUAL 250W H.P.S. LUMINAIRE, 240V, 1 PHASE, 2 WIRE
- DUAL 400W H.P.S. LUMINAIRE, 240V, 1 PHASE, 2 WIRE
- 2# AWG & 1# AWG GROUND, 600V. (XLP-TYPE USE) ROUTED IN 2" RIGID GALVANIZED STEEL CONDUIT.
- 4# AWG & 1# AWG GROUND, 600V. (XLP-TYPE USE) ROUTED IN 2" RIGID GALVANIZED STEEL CONDUIT.
- PROPOSED LIGHTING CONTROLLER
- CIRCUITING DESIGNATION SCHEME
- # - DENOTES POLE NO. ON GIVEN CIRCUIT
LETTER - DENOTES CIRCUIT DESIGNATION (A THROUGH H)
S - DENOTES CONTROLLER CABINET LABEL
- (N#) IDENTIFIES NODE POINT USED IN VOLTAGE DROP CALCS.

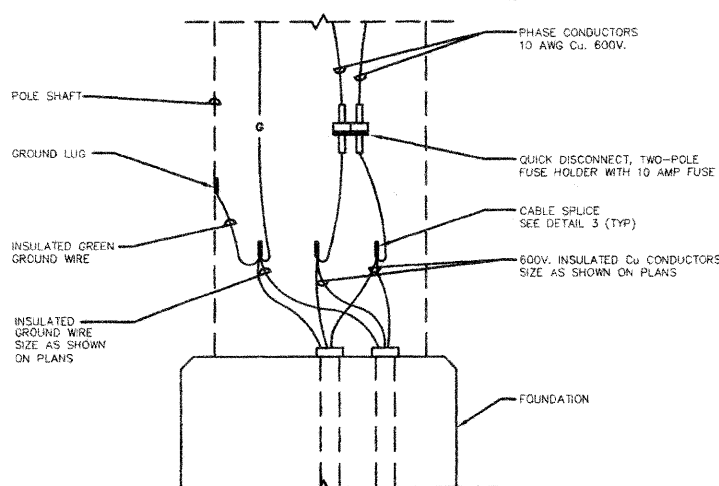

2 POLE BASE WIRING DIAGRAM
NO SCALE

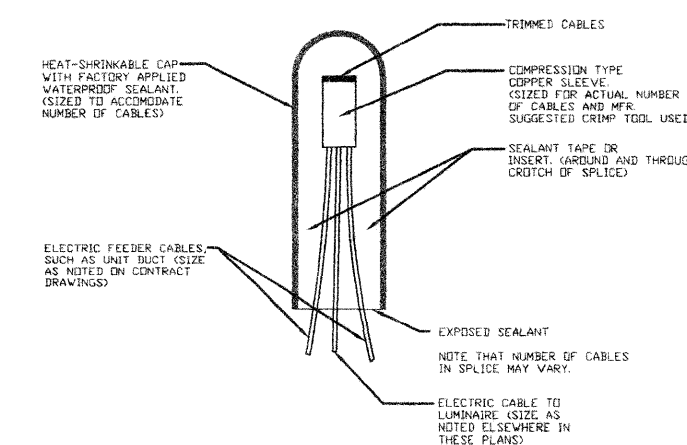

3 SPLICING ELECTRIC CABLES BASIC MATERIALS AND METHODS
NO SCALE

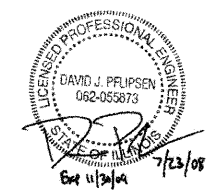

ENGINEERING CONSULTANTS
1721 W. BIEHL ROAD, SUITE 000
NAPERVILLE, IL 60563
630.527.2528 FAX: 630.527.2382
www.jaw.com
PROJECT: 054151

EXPERIENCE YOU CAN BUILD ON™

KJWW ENGINEERING RESERVES PROPRIETARY RIGHTS, INCLUDING COPYRIGHTS, TO THIS DRAWING AND THE DATA SHOWN THEREON. SAID DRAWING AND/OR DATA ARE THE EXCLUSIVE PROPERTY OF KJWW ENGINEERING AND SHALL NOT BE USED OR REPRODUCED FOR ANY OTHER PROJECT WITHOUT THE EXPRESS WRITTEN APPROVAL AND PARTICIPATION OF KJWW ENGINEERING. © 2005 KJWW, P.C.

REFERENCE SCALE IN INCHES
0 1 2 3

PLANS PREPARED BY:
GEWALT HAMILTON ASSOCIATES, INC.
Consulting Engineers & Surveyors
650 Forest Ridge Drive
Verona Hills, IL 60061
(847) 478-9700
(847) 478-9701 Fax

REVISIONS	
NAME	DATE

ILLINOIS DEPARTMENT OF TRANSPORTATION
LIGHTING WIRING DIAGRAM

IRVING PARK ROAD LIGHTING
STREAMWOOD, ILLINOIS

SCALE: N.T.S.
DATE: 6-16-08

DRAWN BY: DRS
DESIGNED BY: AJP
CHECKED BY: BLS

CONTRACT NO. 63068

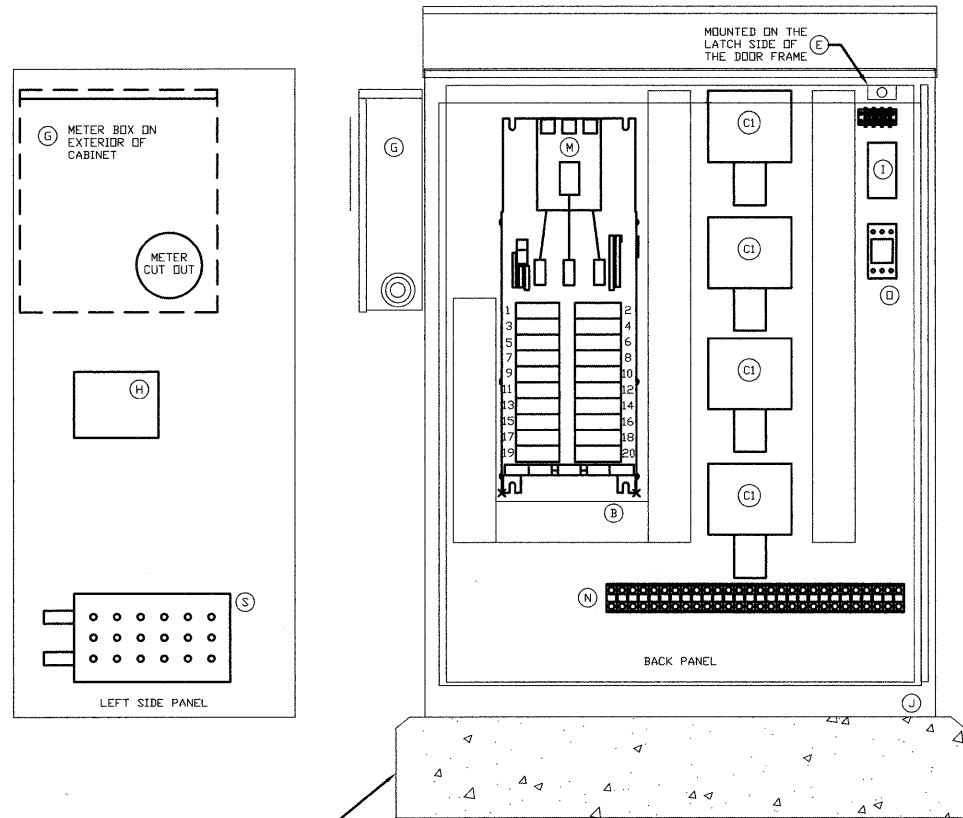

FOUNDATION SIZED TO FIT CABINET. REFER TO FOUNDATION TYPE D PER STATE STANDARD 878001 - CONCRETE FOUNDATION DETAILS.

1 LIGHTING CONTROL CABINET

NO SCALE

NOTES:
1. LIGHTING CONTROLLER DOOR SHALL OPEN TO ALLOW MAINTAINER TO SEE/FACE ONCOMING TRAFFIC.

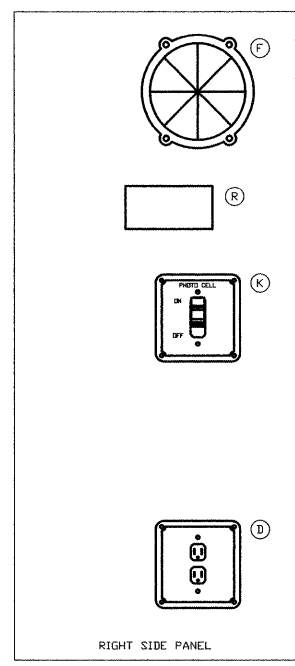

2 CABINET ELEMENTARY DIAGRAM

NO SCALE

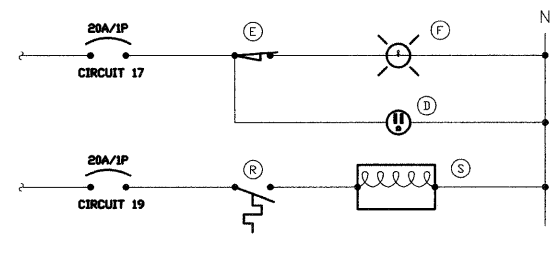

BILL OF MATERIALS FOR LIGHTING CONTROLLER "S"		
ITEM #	QUANTITY	DESCRIPTION
B	1	BRANCH CIRCUIT PANEL INTERIOR, 200A COPPER BUS, 240/120VOLT, MOLDED CASE THERMAL MAGNETIC CIRCUIT BREAKERS, BOLT ON TYPE, AIC RATING OF 14,000 AMPS AT 240 VOLTS, SQUARE D 1630-N00020L 100C4 OR APPROVED EQUAL.
C1	4	MECHANICAL CONTACTOR 4 POLE 30 AMP 120V COIL, SQUARE D 8903-LG40V02 OR APPROVED EQUAL.
D	1	GFI RECEPTACLE 120V 20A PREMIUM SPEC. GRADE, NEMA REFERENCE 5-20R IN WEATHER-PROOF BOX WITH FLAP-TYPE COVER, HUBBELL GFS362A, WP26 COVER, OR APPROVED EQUAL.
E	1	20A SPDT MICRO SWITCH (MOUNT WITH ACTUATOR TO SWITCH WHEN DOOR OPENED), 120 VOLT, 15 AMP CONTACTS, SQUARE D XCKL110, OR APPROVED EQUAL.
F	1	60 WATT LIGHT FIXTURE, VAPOR TIGHT WITH GLOBE AND GUARD AND MOUNTING BOX.
G	1	METER FITTING, 1 PHASE, 3 WIRE, 200 AMP.
H	1	SURGE ARRESTOR, BRACKET MOUNTED, 120/240 VOLT SERVICE, G.E. TRANQUELL SLISEBOOL OR APPROVED EQUAL.
I	1	PHOTOCELL, 120/277V, 1800 VA RATED, SINGLE POLE, SINGLE THROW CONTACT, WEATHERPROOF AND CORROSION PROOF ENCLOSURE, U.L. LISTED, TORK 2107 OR APPROVED EQUAL.
J	1	ENCLOSURE PAD MOUNTED, STAINLESS STEEL, N.E.M.A. 4X CONSTRUCTION WITH KEY LOCKING DOOR, KEY CYLINDER SHALL MATCH EXISTING VILLAGE LIGHTING CONTROLLER LOCKS, HOFFMAN, OR APPROVED EQUAL.
K	1	TOGGLE SWITCH, SPDT, 20 AMP, 240 VOLT, SPECIFICATION GRADE MOUNTED IN SURFACE BOX, HUBBELL HBL1221 OR APPROVED EQUAL.
M	1	MAIN CIRCUIT BREAKER, MOLDED CASE THERMAL MAGNETIC, SERVICE ENTRANCE DUTY RATED 240 VOLT, 200 AMP, 2 POLE, AIC RATING OF 14,000 AMPS AT 240 VOLTS, INTEGRAL TO BRANCH PANEL.
N	1	COPPER LOAD TERMINAL BLOCK FOR AWG#6 AND AWG#12.
O	1	FORM TYPE C RELAY, ELECTRICALLY HELD, ONE NORMALLY OPEN (N.O.) AND ONE NORMALLY CLOSED (N.C.) CONTACTS, 600V CONTINUOUS DUTY COIL, 30 AMP CONTACT RATING, SQUARE D CLASS 8501 OR APPROVED EQUAL.
R	1	THERMOSTAT, 40-80 DEGREE RANGE, CHROMALUX WR80 OR APPROVED EQUAL.
S	1	HEATER, 120 VOLT, 375 WATT, 40-80 DEGREE THERMOSTAT, CHROMALUX 276-10 OR APPROVED EQUAL.

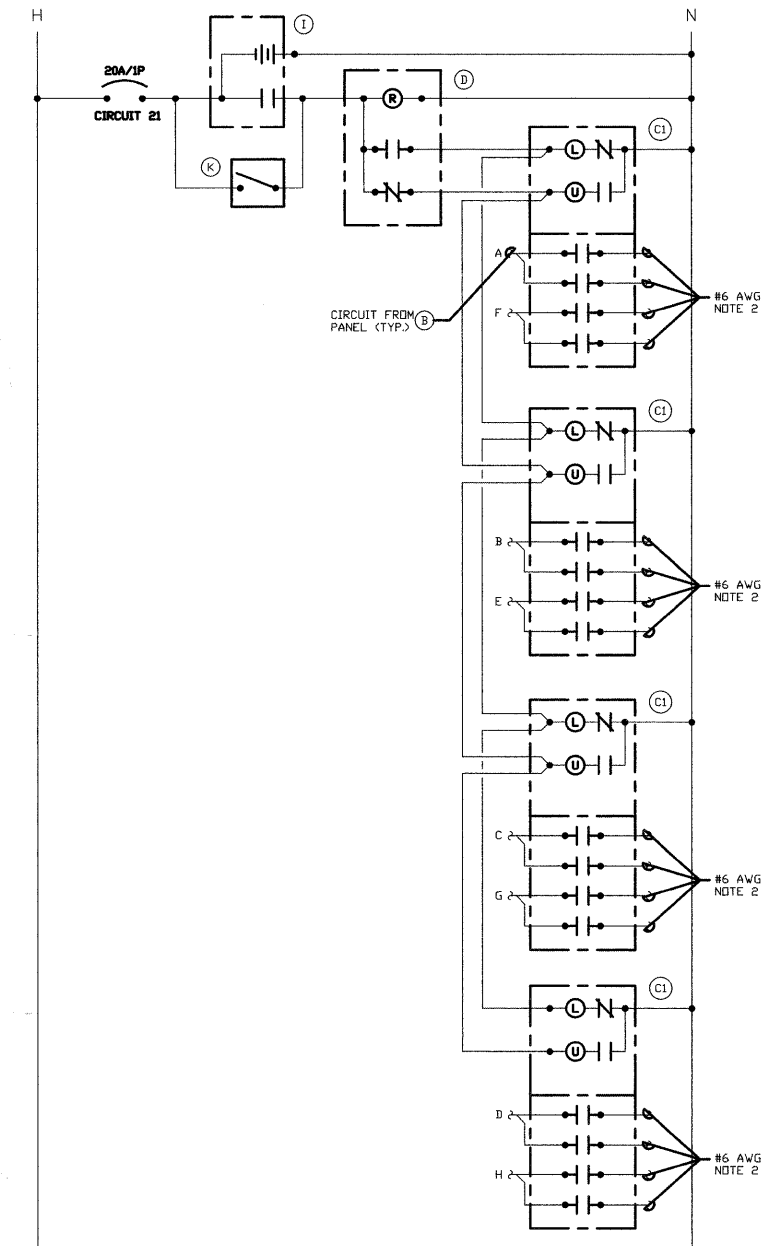

3 LIGHTING CONTROL ELEMENTARY DIAGRAM

NO SCALE

NOTES:
1. ALL CABINET INTERIOR WIRING SHALL BE STRANDED COPPER #12 AWG THWN UNLESS NOTED OTHERWISE.
2. ROUTE TO STREET LIGHTING LUMINAIRES VIA TERMINAL BLOCK.

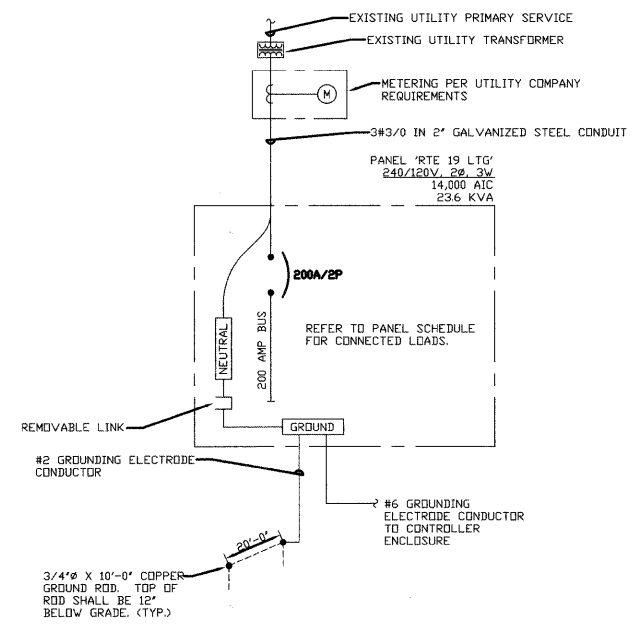

4 ONE LINE DIAGRAM

NO SCALE

TYPE: BOLT-ON MOUNTING SURFACE - INTERIOR ONLY		PANEL NAME: RTE 19 LTG		CONNECTED 23.6 KVA				
FED FROM UTILITY		SOLID NEUTRAL GROUND BUS		MAIN: 200A/2P CB (H)				
AIC RATING: 14,000				VOLTS: 240/120				
				PHASE: 1				
				WIRE: 3				
CKT NO.	LOAD DESCRIPTION	WIRE SIZE	LOAD KVA	BREAKER AMP	BREAKER P	LOAD WIRE SIZE	LOAD DESCRIPTION	CKT NO.
1	CIRCUIT A 8-250W	6	2.6	20	2	2.0	CIRCUIT E 2-400W, 5-250W	2
3								4
5	CIRCUIT B 9-250W	6	3.2	20	2	2.0	CIRCUIT F 2-400W, 5-250W	6
7								8
9	CIRCUIT C 7-250W	6	2.5	20	2	2.0	CIRCUIT G 2-400W, 5-250W	10
11								12
13	CIRCUIT D 7-250W	6	2.5	20	2	3.1	CIRCUIT H 2-400W, 5-250W	14
15								16
17	LIGHT, RECEPT	12	0.3	20	1	20	2	18
19	HEATER	12	0.4	20	1			20
21	LIGHTING CONTROL, PHOTOCCELL	12	0.1	20	1	20	2	22
23	SPARE			20	1			24

PLANS PREPARED BY:
GEWALT HAMILTON ASSOCIATES, INC.
Consulting Engineers & Surveyors
850 Forest Ridge Drive
Vernon Hills, IL, 60061
(847) 478-9700
(847) 478-9701 Fax

REVISIONS	
NAME	DATE

KJV ENGINEERING CONSULTANTS
1771 W. DIEHL ROAD, SUITE 300
WAPERVILLE, IL 60563
630.527.2300 FAX 630.527.2321
www.kjv.com PROJECT #04151
Experience you can build on.

ILLINOIS DEPARTMENT OF TRANSPORTATION
LIGHTING CONTROL CABINET
IRVING PARK ROAD LIGHTING
STREAMWOOD, ILLINOIS

SCALE: N.T.S.
DATE: 6-16-08
DRAWN BY: DRS
DESIGNED BY: AJP
CHECKED BY: BLS

F.A. RTE.	SECTION	COUNTY	TOTAL SHEETS	SHEET NO.
1321	05-00049-00-LT	COOK	9	8
STA.		TO STA.		
FED. ROAD DIST. NO.		ILLINOIS FED. AID PROJECT		
CONTRACT NO. 63068				

LIGHT POLE FOUNDATION DEPTH TABLE
9.144M (30 FT.) TO 10.668M (35 FT.) MOUNTING HEIGHT

SOIL CONDITIONS	DESIGN DEPTH "D" OF FOUNDATION	
	SINGLE ARM POLE	TWIN ARM POLE
SOFT CLAY Q _u = 0.375 TON/SQ. FT.	3.35 (11'-0")	3.85M (12'-8")
MEDIUM CLAY Q _u = 0.75 TON/SQ.FT	2.74M (9'-0")	4.52M (14'-10")
STIFF CLAY Q _u = 1.50 TON/SQ. FT.	2.29M (7'-6")	2.61M (8'-7")
LOOSE SAND φ = 34°	2.90M (9'-6")	3.22M (10'-7")
MEDIUM SAND φ = 37.5°	2.74M (9'-0")	2.99M (9'-10")
DENSE SAND φ = 40°	2.51M (8'-3")	2.91M (9'-7")

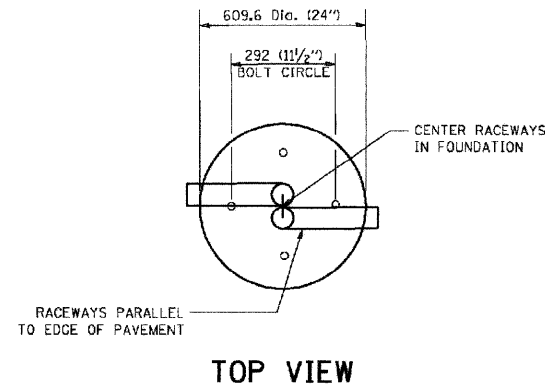

NOTES

- ALL DIMENSIONS ARE IN MILLIMETERS (INCHES) UNLESS OTHERWISE SHOWN.
- THE ANCHOR RODS AND RACEWAYS SHALL BE PROPERLY SECURED IN PLACE BEFORE THE CONCRETE IS PLACED.
- THE FOUNDATION SHALL NOT PROTRUDE MORE THAN 100MM (4 IN.) ABOVE THE FINISHED GRADE WITHIN A 1.5M (60 IN.) CHORD ACROSS THE FOUNDATION, WITH ANCHOR RODS INCLUDED, IN ACCORDANCE WITH AASHTO GUIDELINES. IF THE FOUNDATION HEIGHT, INCLUDING ANCHOR RODS, EXTENDS BEYOND THESE SPECIFIED LIMITS, THE FOUNDATION SHALL BE REPLACED AT THE CONTRACTOR'S EXPENSE. SEE FOUNDATION EXTENSION DETAIL.
- THE HOLE FOR THE FOUNDATION SHALL BE MADE BY DRILLING WITH AN AUGER, OF THE SAME DIAMETER AS THE FOUNDATION. IF SOIL CONDITIONS REQUIRE THE USE OF A LINER TO FORM THE HOLE, THE LINER SHALL BE WITHDRAWN AS THE CONCRETE IS DEPOSITED.
- THE TOP OF THE FOUNDATION SHALL BE CONSTRUCTED LEVEL. A LINER OR FORM SHALL BE USED TO PRODUCE A UNIFORM SMOOTH SIDE TO THE TOP OF THE FOUNDATION. FOUNDATION TOP SHALL BE CHAMFERED 20MM (3/4-IN.).
- THE CONCRETE SHALL BE CLASS S1. CONCRETE SHALL CURE ACCORDING TO ARTICLE 1020.13 BEFORE LIGHT POLES ARE INSTALLED.
- THE ANCHOR ROD SHALL BE A HOOK ROD TYPE. COLD BENDING OF THE ANCHOR ROD WILL NOT BE ALLOWED. THE RADIUS OF THE HOOK BEND SHALL NOT BE LESS THAN 4 TIMES THE NOMINAL DIAMETER OF THE ANCHOR ROD. A TACK WELDED ANCHOR ROD MAY BE SUBSTITUTED WITH THE APPROVAL OF THE ENGINEER.
- THE ANCHOR RODS SHALL BE ACCORDING TO ASTM F1554 GRADE 725 (GRADE 105). NUTS SHALL BE HEXAGON NUTS ACCORDING TO ASTM A 194 2H OR ASTM A 563 DH, AND WASHERS SHALL BE ACCORDING TO ASTM F 436.
- ANCHOR RODS, NUTS AND WASHERS SHALL BE COMPLETELY GALVANIZED BY EITHER THE HOT-DIPPED PROCESS CONFORMING WITH AASHTO M 232, THE MECHANICAL PLATING METHOD CONFORMING TO AASHTO M 298, CLASS 50 WITH A MAXIMUM COATING THICKNESS OF 150 UMG (MILS) OR THE ELECTROLYTIC PROCESS ACCORDING TO ASTM F 1136.
- THE ANCHOR RODS SHALL BE THREADED A MINIMUM OF 150 MM (6 INCHES) WITH A MINIMUM OF 75 MM (3 INCHES) OF THREADED ANCHOR ROD EMBEDDED IN THE FOUNDATION.
- ANCHOR RODS SHALL PROJECT 69.9MM (2 3/4") ABOVE THE TOP OF THE FOUNDATION. IF BREAKAWAY COUPLINGS ARE SPECIFIED, THE CONTRACTOR SHALL CAREFULLY COORDINATE THE ANCHOR ROD PROJECTION WITH THE INSTALLATION REQUIREMENTS OF THE BREAKAWAY COUPLINGS.
- THE CONTRACTOR SHALL USE A #3 SPIRAL AT 152.4MM (6") PITCH OR MAY SUBSTITUTE #3 TIES AT 304.8MM (12") O.C. WITH THE APPROVAL OF THE ENGINEER.
- THE CABLE TRENCHES AND FOUNDATION SHALL BE BACK FILLED AND COMPACTED AS SPECIFIED BEFORE THE LIGHT POLE IS ERRECTED.
- THE RACEWAYS SHALL PROJECT 25.4MM (1") ABOVE THE TOP OF THE FOUNDATION.

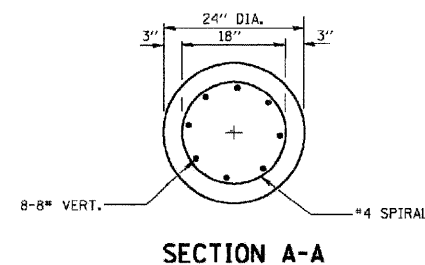
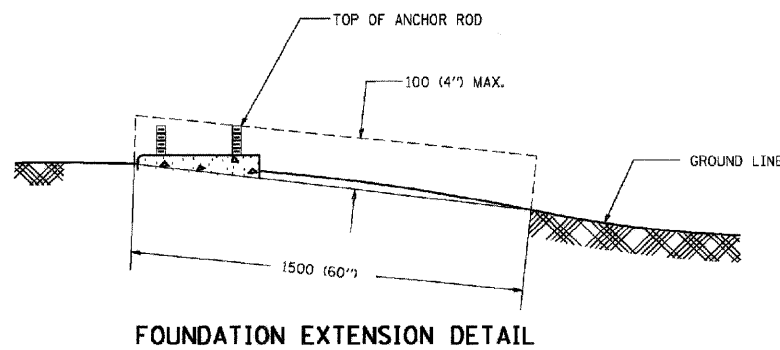
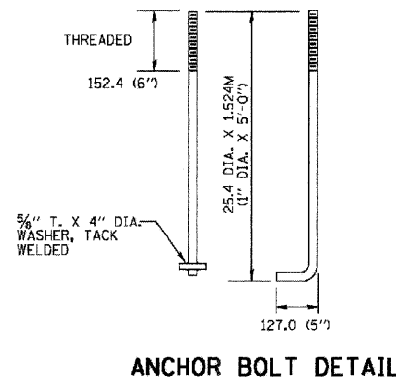
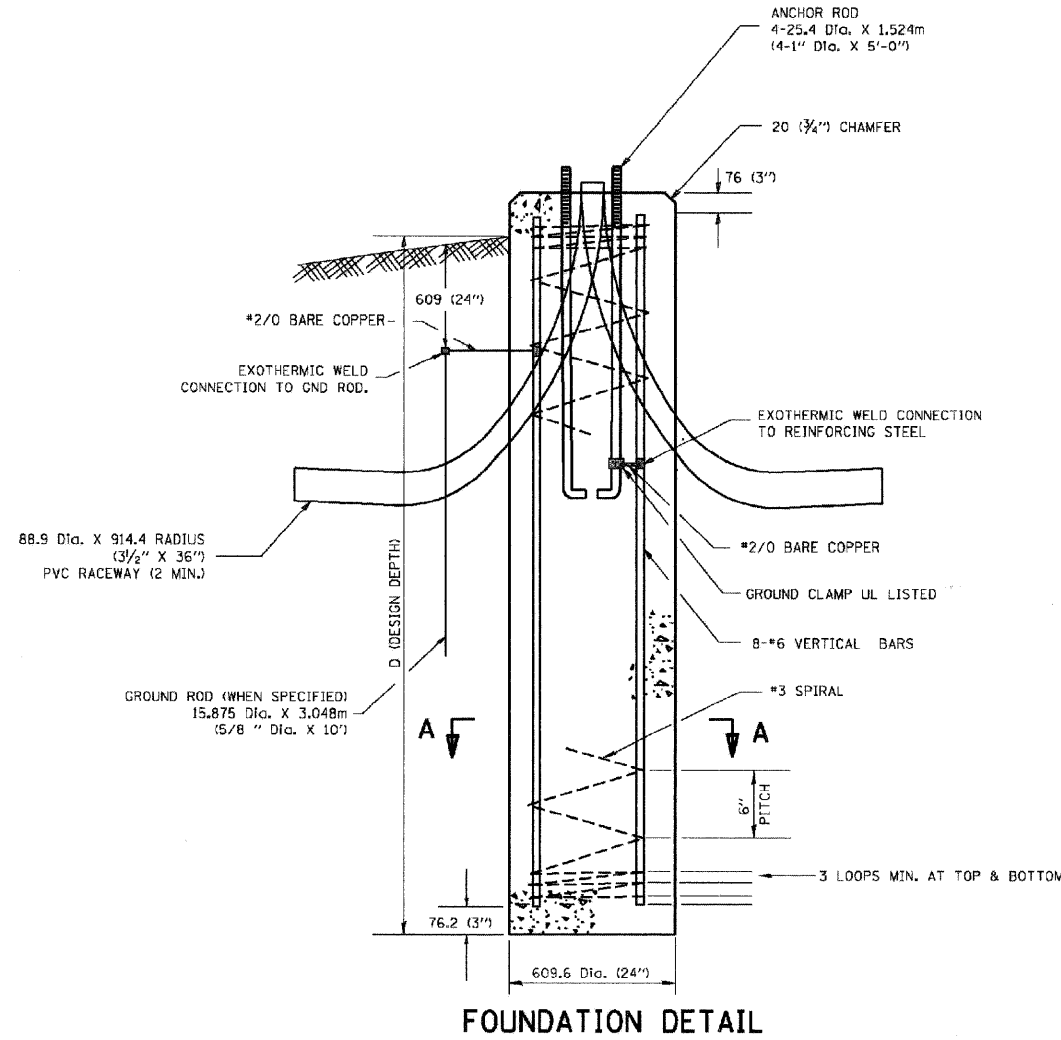

PLOT SCALE = 4:1 (1/4" = 1'-0")
 USER NAME = gajlancob

REVISIONS	
NAME	DATE
D. SIMON	4/93
D. DREW	06/15/95

ILLINOIS DEPARTMENT OF TRANSPORTATION
LIGHT POLE FOUNDATION
9.144M (30') TO 10.668M (35') M.H.
292mm (11 1/2) BOLT CIRCLE

SCALE: NONE
 DATE: 2/15/2006

DRAWN BY
 CHECKED BY
 E-300 (BE-300)
 REVISION DATE: 12/18/02

LUMEC

640, Curé-Bovin
Boisbrand (Québec)
Canada, J7G 2A7

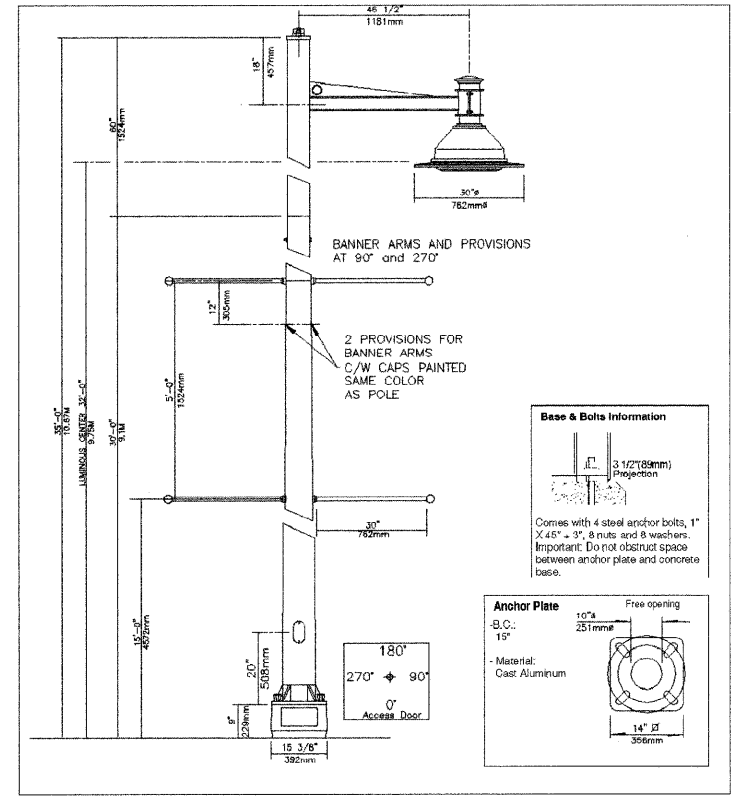

LMS49375C1-30052(SA)JFD.DOC 05-30-2008 Page 1 / 5
PHILIPS

LUMINAIRE: TR20-250HPS-SG2-OTA/240-BRTX-LMS49375C
HOOD: CAST 356 ALUMINUM DOME, MECHANICALLY ASSEMBLED ON THE LUMINAIRE.
SKIRT: SPUN 1100-0 ALUMINUM, MECHANICALLY ASSEMBLED ON THE LUMINAIRE.
LAMP: 250 WATT HIGH PRESSURE SODIUM (ANSI CODE S50), ED 18 BULB, MOGUL BASE.
OPTICAL SYSTEM: (SG2), I.E.S. TYPE II (ASYMMETRICAL), REFLECTOR COMPOSED OF A CHEMICALLY BRIGHTENED MULTI-FACETED ANODIZED ALUMINUM, MOUNTED ON A WHITE FRAME. THIS ASSEMBLY ALLOWS FOR A FULL ROTATION OF THE OPTICAL SYSTEM IN 90 DEGREE INCREMENTS.
BALLAST: HIGH POWER FACTOR OF 90%. PRIMARY VOLTAGE 120/208/240/277 VOLTS, CONNECTED TO 240 VOLTS. LAMP STARTING CAPACITY -40F (-40C) DEGREES. ASSEMBLED ON A UNITIZED REMOVABLE TRAY WITH QUICK DISCONNECT PLUG.
ACCESS-MECHANISM: A DIE CAST ALUMINUM TECHNICAL RING WITH LATCH AND HINGE. THE MECHANISM SHALL OFFER TOOLFREE ACCESS TO THE INSIDE OF THE LUMINAIRE. AN EMBEDDED MEMORY-RETENTIVE GASKET SHALL ENSURE WEATHERPROOFING.
BRACKET: UN-1A-90DEG-BRTX-LMS49375C
ARM: SHALL BE MADE FROM EXTRUDED ALUMINUM 6063-T4, WELDED.
ADAPTOR: CLAMPS MADE OF CAST 356 ALUMINUM, WELDED TO THE ARM AND MECHANICALLY FASTENED TO THE LUMINAIRE BY STAINLESS STEEL BOLTS AND NUTS.
CENTRAL ADAPTOR: MADE OF ALUMINUM, 6" (152.4MM) O.D., C/W A TENON PENETRATING 12" (305MM) INSIDE THE POLE, MECHANICALLY SECURED.
BRACKET OPTIONS: (90 DEG), BRACKET TO BE ORIENTED AT 90 DEGREE FROM ACCESS DOOR.
POLE: ATR106N-20-25-BA-BRTX-LMS49375C
POLE SHAFT: MADE OF ALUMINUM 6063-T4, ROUND, TEMPERED TO T6 AFTER WELDING, HAVING A BASE DIAMETER OF 10" (254MM) AND TOP DIAMETER OF 6" (152MM) WALL THICKNESS 0.188" (4.8MM) WELDED TO BOTH THE BOTTOM AND TOP OF THE ANCHOR PLATE. C/W BANNER PROVISIONS.
MAINTENANCE OPENING: THE POLE SHALL HAVE A 4" X 8" (102MM X 203MM) MAINTENANCE OPENING CENTERED 20" (508MM) FROM THE BOTTOM OF THE ANCHOR PLATE, COMPLETE WITH A WEATHERPROOF ALUMINUM COVER AND A COPPER GROUND LUG.
NUT COVER: MADE FROM SPUN ALUMINUM.
POLE OPTIONS: (BA) TWO WAY (180 DEG), UPPER AND LOWER ARMS (2), FIXED STANDARD TYPE, MADE OF ALUMINUM TUBING, 1 1/16" (27MM) OUTSIDE DIAMETER, MECHANICALLY ASSEMBLED TO THE POLE, COMPLETE WITH A STANDARD CAST ALUMINUM DECORATIVE BALL.
MISCELLANEOUS: BT-BRTX-LMS49375C
TRANSITION BASE: MADE OF ALUMINUM 356, C/W ACCESS DOOR COVERING AN OPENING OF 11" X 5 1/2" (279MM X 139MM).
WIRING: GAUGE (#14) TEW WIRES, 6" (152MM) MINIMUM EXCEEDING THE BRACKET.
HARDWARE: ALL EXPOSED SCREWS WILL BE IN STAINLESS STEEL. ALL SEALS AND SEALING DEVICES ARE MADE AND/OR LINED WITH EPDM AND/OR SILICONE.
FINISH: COLOR TO BE BRONZE TEXTURED (BRTX). APPLICATION OF A POLYESTER POWDER COAT PAINT. (4 MILS/100 MICRONS). THE CHEMICAL COMPOSITION PROVIDES A HIGHLY DURABLE UV AND SALT SPRAY RESISTANT FINISH IN ACCORDANCE TO THE ASTM-B117-73 STANDARD AND HUMIDITY PROOF IN ACCORDANCE TO THE ASTM-D2247-68 STANDARD.
LIGHTING UNIT ASSEMBLY SHALL MEET AASHTO LOADING REQUIREMENTS AND SHALL BE UL CLASSIFIED.

LUMEC

640, Curé-Bovin
Boisbrand (Québec)
Canada, J7G 2A7

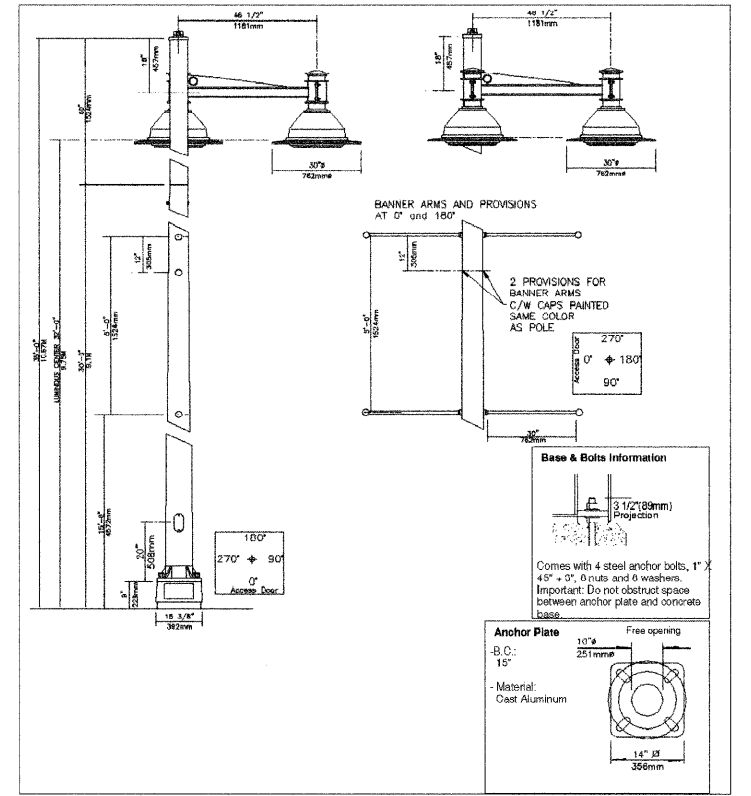

LMS49375E0-30052(SA)JFD.DOC 05-30-2008 Page 1 / 5
PHILIPS

LUMINAIRE: TR20-250HPS-SG2-OTA/240-BRTX-LMS49375E
HOOD: CAST 356 ALUMINUM DOME, MECHANICALLY ASSEMBLED ON THE LUMINAIRE.
SKIRT: SPUN 1100-0 ALUMINUM, MECHANICALLY ASSEMBLED ON THE LUMINAIRE.
LAMP: 250 WATT HIGH PRESSURE SODIUM (ANSI CODE S50), ED 18 BULB, MOGUL BASE.
OPTICAL SYSTEM: (SG2), I.E.S. TYPE II (ASYMMETRICAL), REFLECTOR COMPOSED OF A CHEMICALLY BRIGHTENED MULTI-FACETED ANODIZED ALUMINUM, MOUNTED ON A WHITE FRAME. THIS ASSEMBLY ALLOWS FOR A FULL ROTATION OF THE OPTICAL SYSTEM IN 90 DEGREE INCREMENTS.
BALLAST: HIGH POWER FACTOR OF 90%. PRIMARY VOLTAGE 120/208/240/277 VOLTS, CONNECTED TO 240 VOLTS. LAMP STARTING CAPACITY -40F (-40C) DEGREES. ASSEMBLED ON A UNITIZED REMOVABLE TRAY WITH QUICK DISCONNECT PLUG.
ACCESS-MECHANISM: A DIE CAST ALUMINUM TECHNICAL RING WITH LATCH AND HINGE. THE MECHANISM SHALL OFFER TOOLFREE ACCESS TO THE INSIDE OF THE LUMINAIRE. AN EMBEDDED MEMORY-RETENTIVE GASKET SHALL ENSURE WEATHERPROOFING.
BRACKET: UN-2A-BRTX-LMS49375E
ARM: SHALL BE MADE FROM EXTRUDED ALUMINUM 6063-T4, WELDED.
ADAPTOR: CLAMPS MADE OF CAST 356 ALUMINUM, WELDED TO THE ARM AND MECHANICALLY FASTENED TO THE LUMINAIRE BY STAINLESS STEEL BOLTS AND NUTS.
CENTRAL ADAPTOR: MADE OF ALUMINUM, 6" (152.4MM) O.D., C/W A TENON PENETRATING 12" (305MM) INSIDE THE POLE, MECHANICALLY SECURED.
POLE: ATR106V-20-25-BA-BRTX-LMS49375E
POLE SHAFT: MADE OF ALUMINUM 6063-T4, ROUND, TEMPERED TO T6 AFTER WELDING, HAVING A BASE DIAMETER OF 10" (254MM) AND TOP DIAMETER OF 6" (152MM) WALL THICKNESS 0.188" (4.8MM) WELDED TO BOTH THE BOTTOM AND TOP OF THE ANCHOR PLATE. C/W BANNER PROVISIONS.
MAINTENANCE OPENING: THE POLE SHALL HAVE A 4" X 8" (102MM X 203MM) MAINTENANCE OPENING CENTERED 20" (508MM) FROM THE BOTTOM OF THE ANCHOR PLATE, COMPLETE WITH A WEATHERPROOF ALUMINUM COVER AND A COPPER GROUND LUG.
NUT COVER: MADE FROM SPUN ALUMINUM.
POLE OPTIONS: (BA) TWO WAY (180 DEG), UPPER AND LOWER ARMS (2), FIXED STANDARD TYPE, MADE OF ALUMINUM TUBING, 1 1/16" (27MM) OUTSIDE DIAMETER, MECHANICALLY ASSEMBLED TO THE POLE, COMPLETE WITH A STANDARD CAST ALUMINUM DECORATIVE BALL.
MISCELLANEOUS: BT-BRTX-LMS49375E
TRANSITION BASE: MADE OF ALUMINUM 356, C/W ACCESS DOOR COVERING AN OPENING OF 11" X 5 1/2" (279MM X 139MM).
WIRING: GAUGE (#14) TEW WIRES, 6" (152MM) MINIMUM EXCEEDING THE BRACKET.
HARDWARE: ALL EXPOSED SCREWS WILL BE IN STAINLESS STEEL. ALL SEALS AND SEALING DEVICES ARE MADE AND/OR LINED WITH EPDM AND/OR SILICONE.
FINISH: COLOR TO BE BRONZE TEXTURED (BRTX). APPLICATION OF A POLYESTER POWDER COAT PAINT. (4 MILS/100 MICRONS). THE CHEMICAL COMPOSITION PROVIDES A HIGHLY DURABLE UV AND SALT SPRAY RESISTANT FINISH IN ACCORDANCE TO THE ASTM-B117-73 STANDARD AND HUMIDITY PROOF IN ACCORDANCE TO THE ASTM-D2247-68 STANDARD.
LIGHTING UNIT ASSEMBLY SHALL MEET AASHTO LOADING REQUIREMENTS AND SHALL BE UL CLASSIFIED.

LUMEC

640, Curé-Bovin
Boisbrand (Québec)
Canada, J7G 2A7

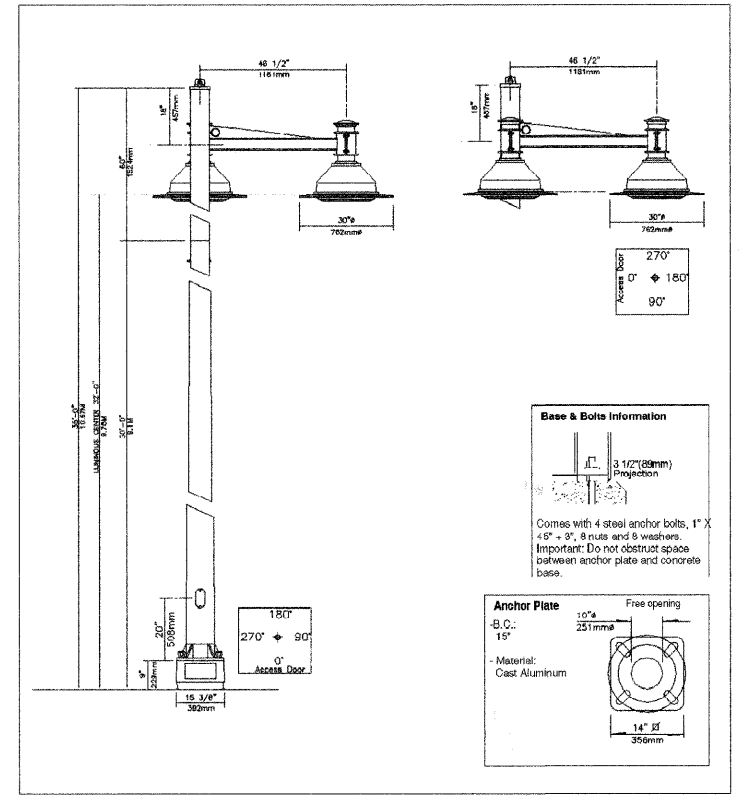

LMS49375F0-30052(SA)JFD.DOC 05-30-2008 Page 1 / 5
PHILIPS

LUMINAIRE: TR20-400HPS-SG2-OTA/240-BRTX-LMS49375F
HOOD: CAST 356 ALUMINUM DOME, MECHANICALLY ASSEMBLED ON THE LUMINAIRE.
SKIRT: SPUN 1100-0 ALUMINUM, MECHANICALLY ASSEMBLED ON THE LUMINAIRE.
LAMP: 400 WATT HIGH PRESSURE SODIUM (ANSI CODE S50), ED 18 BULB, MOGUL BASE.
OPTICAL SYSTEM: (SG2), I.E.S. TYPE II (ASYMMETRICAL), REFLECTOR COMPOSED OF A CHEMICALLY BRIGHTENED MULTI-FACETED ANODIZED ALUMINUM, MOUNTED ON A WHITE FRAME. THIS ASSEMBLY ALLOWS FOR A FULL ROTATION OF THE OPTICAL SYSTEM IN 90 DEGREE INCREMENTS.
BALLAST: HIGH POWER FACTOR OF 90%. PRIMARY VOLTAGE 120/208/240/277 VOLTS, CONNECTED TO 240 VOLTS. LAMP STARTING CAPACITY -40F (-40C) DEGREES. ASSEMBLED ON A UNITIZED REMOVABLE TRAY WITH QUICK DISCONNECT PLUG.
REMOTE BALLAST: LOCATED INSIDE TRANSITION BASE.
ACCESS-MECHANISM: A DIE CAST ALUMINUM TECHNICAL RING WITH LATCH AND HINGE. THE MECHANISM SHALL OFFER TOOLFREE ACCESS TO THE INSIDE OF THE LUMINAIRE. AN EMBEDDED MEMORY-RETENTIVE GASKET SHALL ENSURE WEATHERPROOFING.
BRACKET: UN-2A-BRTX-LMS49375F
ARM: SHALL BE MADE FROM EXTRUDED ALUMINUM 6063-T4, WELDED.
ADAPTOR: CLAMPS MADE OF CAST 356 ALUMINUM, WELDED TO THE ARM AND MECHANICALLY FASTENED TO THE LUMINAIRE BY STAINLESS STEEL BOLTS AND NUTS.
CENTRAL ADAPTOR: MADE OF ALUMINUM, 6" (152.4MM) O.D., C/W A TENON PENETRATING 12" (305MM) INSIDE THE POLE, MECHANICALLY SECURED.
POLE: ATR106N-20-25-BA-BRTX-LMS49375F
POLE SHAFT: MADE OF ALUMINUM 6063-T4, ROUND, TEMPERED TO T6 AFTER WELDING, HAVING A BASE DIAMETER OF 10" (254MM) AND TOP DIAMETER OF 6" (152MM) WALL THICKNESS 0.188" (4.8MM) WELDED TO BOTH THE BOTTOM AND TOP OF THE ANCHOR PLATE. C/W BANNER PROVISIONS.
MAINTENANCE OPENING: THE POLE SHALL HAVE A 4" X 8" (102MM X 203MM) MAINTENANCE OPENING CENTERED 20" (508MM) FROM THE BOTTOM OF THE ANCHOR PLATE, COMPLETE WITH A WEATHERPROOF ALUMINUM COVER AND A COPPER GROUND LUG.
NUT COVER: MADE FROM SPUN ALUMINUM.
MISCELLANEOUS: BT-BRTX-LMS49375F
TRANSITION BASE: MADE OF ALUMINUM 356, C/W ACCESS DOOR COVERING AN OPENING OF 11" X 5 1/2" (279MM X 139MM).
WIRING: GAUGE (#14) TEW WIRES, 6" (152MM) MINIMUM EXCEEDING THE BRACKET.
HARDWARE: ALL EXPOSED SCREWS WILL BE IN STAINLESS STEEL. ALL SEALS AND SEALING DEVICES ARE MADE AND/OR LINED WITH EPDM AND/OR SILICONE.
FINISH: COLOR TO BE BRONZE TEXTURED (BRTX). APPLICATION OF A POLYESTER POWDER COAT PAINT. (4 MILS/100 MICRONS). THE CHEMICAL COMPOSITION PROVIDES A HIGHLY DURABLE UV AND SALT SPRAY RESISTANT FINISH IN ACCORDANCE TO THE ASTM-B117-73 STANDARD AND HUMIDITY PROOF IN ACCORDANCE TO THE ASTM-D2247-68 STANDARD.
LIGHTING UNIT ASSEMBLY SHALL MEET AASHTO LOADING REQUIREMENTS AND SHALL BE UL CLASSIFIED.

F.A.U. R.T.E.	SECTION	COUNTY	TOTAL SHEETS	SHEET NO.
1321	05-00049-00-LT	COOK	9	9
LIGHTING DETAILS				
ILLINOIS				

CONTRACT NO. 63068

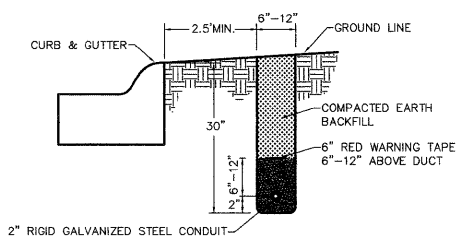

NOTE:
1. ALL SURFACES MUST BE RESTORED TO ORIGINAL CONDITION.

**CONDUIT
TRENCH AND BACKFILL**

PLANS PREPARED BY:
**GEWALT HAMILTON
ASSOCIATES, INC.**
Consulting Engineers & Surveyors
850 Forest Edge Drive
Vernon Hills, IL 60061
(847) 478-9700
(847) 478-9701 Fax

REVISIONS	
NAME	DATE

ILLINOIS DEPARTMENT OF TRANSPORTATION
LIGHTING DETAILS

IRVING PARK ROAD LIGHTING
STREAMWOOD, ILLINOIS

SCALE: N.T.S.
DATE: 6-16-08

DRAWN BY: DRS
DESIGNED BY: AJP
CHECKED BY: BLS