

- LEGEND**
- ① TEMPORARY PAVEMENT MARKING - 4 INCH WHITE
 - ② TEMPORARY PAVEMENT MARKING - 4 INCH YELLOW
 - ③ DRUM W/STEADY BURN MONODIRECTIONAL LIGHT
 - ④ EXISTING PAVEMENT MARKING
 - ⑤ TEMPORARY CONCRETE BARRIER
 - ⑥ TEMPORARY PAVEMENT MARKING - 6 INCH WHITE W/TEMPORARY RAISED REFLECTIVE PAVEMENT MARKER
 - ⑦ TEMPORARY PAVEMENT MARKING PLACED IN PREVIOUS STAGE
 - ⑧ WET REFLECTIVE TEMPORARY TAPE - 4 INCH (WHITE)
 - ⑨ WET REFLECTIVE TEMPORARY TAPE - 4 INCH (YELLOW)
- WORK AREA
 - TEMPORARY PAVEMENT PLACED PREVIOUS STAGE
 - TEMPORARY PAVEMENT PLACED THIS STAGE

NOTE:
SEE TEMPORARY PAVEMENT (CROSSOVER) DETAIL SHEETS FOR SPOT ELEVATIONS.

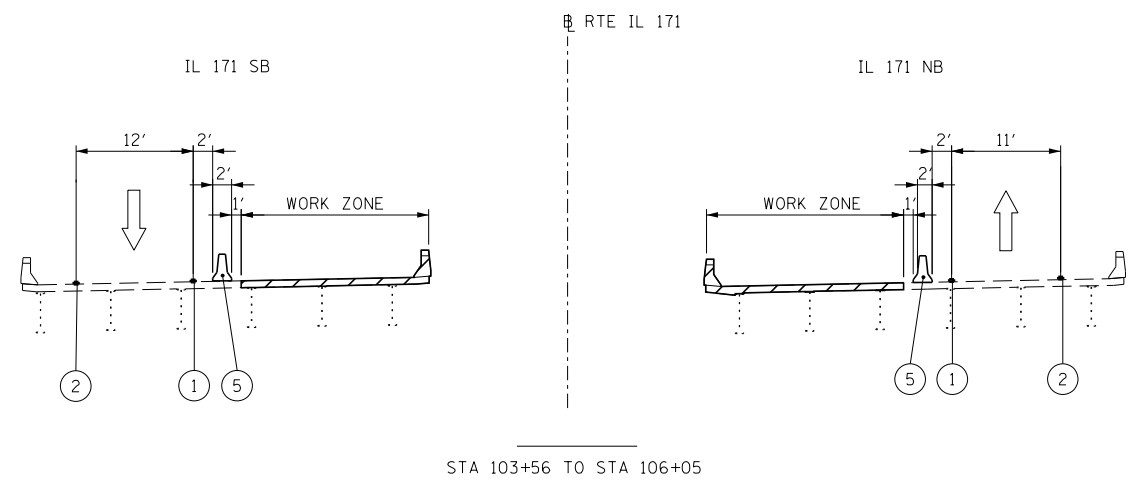

FILE NAME =	DESIGNED - AAA	REVISED -
...\\D160J16-sht-MOT-extyp-stgIA-02.dgn	DRAWN - TMB	REVISED -
USER NAME = tblank	CHECKED - JMM	REVISED -
PLOT DATE = 8/7/2014	DATE - 6/23/2014	REVISED -

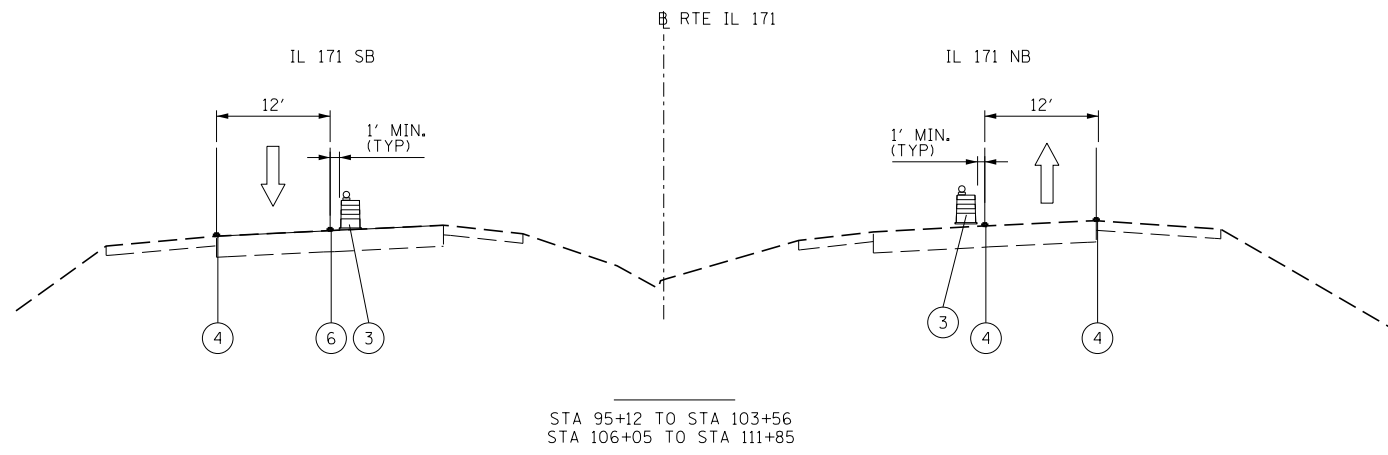

**STATE OF ILLINOIS
DEPARTMENT OF TRANSPORTATION**

**MAINTENANCE OF TRAFFIC
STAGE 1A**

SHEET 15 OF 50 SHEETS STA. TO STA.

F.A.P. RTE.	SECTION	COUNTY	TOTAL SHEETS	SHEET NO.
372/373	2013-038B-R	COOK	821	76
CONTRACT NO. 60J16			ILLINOIS FED. AID PROJECT	