

TYPICAL LIGHTED SIGN STRUCTURE WIRING DIAGRAM

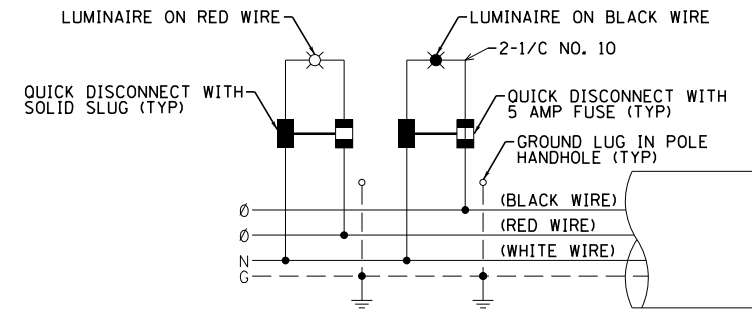

TYPICAL LIGHT POLE WIRING DIAGRAM

LEGEND (THIS SHEET ONLY):

- UNIT DUCT OR CABLE IN CONDUIT
- ⊥ ELECTRIC GROUND ROD
- ⊕ UNDERPASS LUMINAIRE, 100W HPS, 240V ON RED WIRE
- ⊖ UNDERPASS LUMINAIRE, 100W HPS, 240V ON BLACK WIRE
- ⊗ LIGHTING CONTROLLER, BASE MOUNTED, 240/480V, 200 AMP (DUAL), 1 PHASE, 3 WIRE, RADIO SCADA
- ⊠ ELECTRIC SERVICE INSTALLATION
- 240V 400W HPS MC3 HORIZONTAL MOUNT LUMINAIRE ON RED WIRE
- 240V 400W HPS MC3 HORIZONTAL MOUNT LUMINAIRE ON BLACK WIRE
- ⊙ TEMPORARY LIGHTING UNIT, WOOD POLE WITH 2-15' MAST ARMS AND 400W HPS HIGH MAST LUMINAIRES
- ⊕ HIGH MAST LIGHT TOWER, SEE TYPICAL WIRING DIAGRAM
- ⊖ 750 W HPS LUMINAIRE - RED PHASE (SOLID ON BLACK PHASE)
- 2 MAB 4 HIGH MAST TOWER DESIGNATION
- ⊠ LIGHTED SIGN STRUCTURE BLACK PHASE (RED PHASE SHOWN OPEN) SEE TYPICAL WIRING DIAGRAM BELOW.
- ⊙ NAVIGATION LIGHT

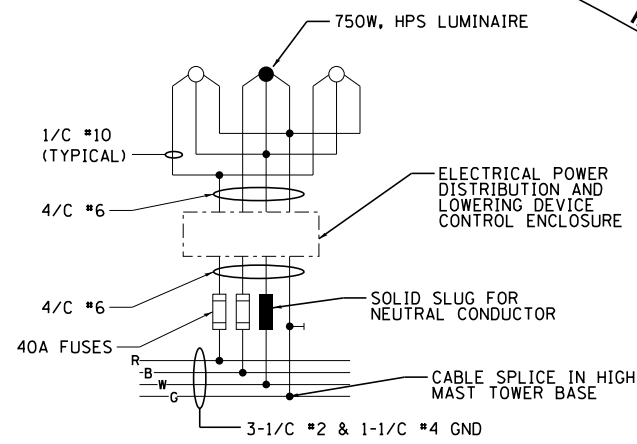
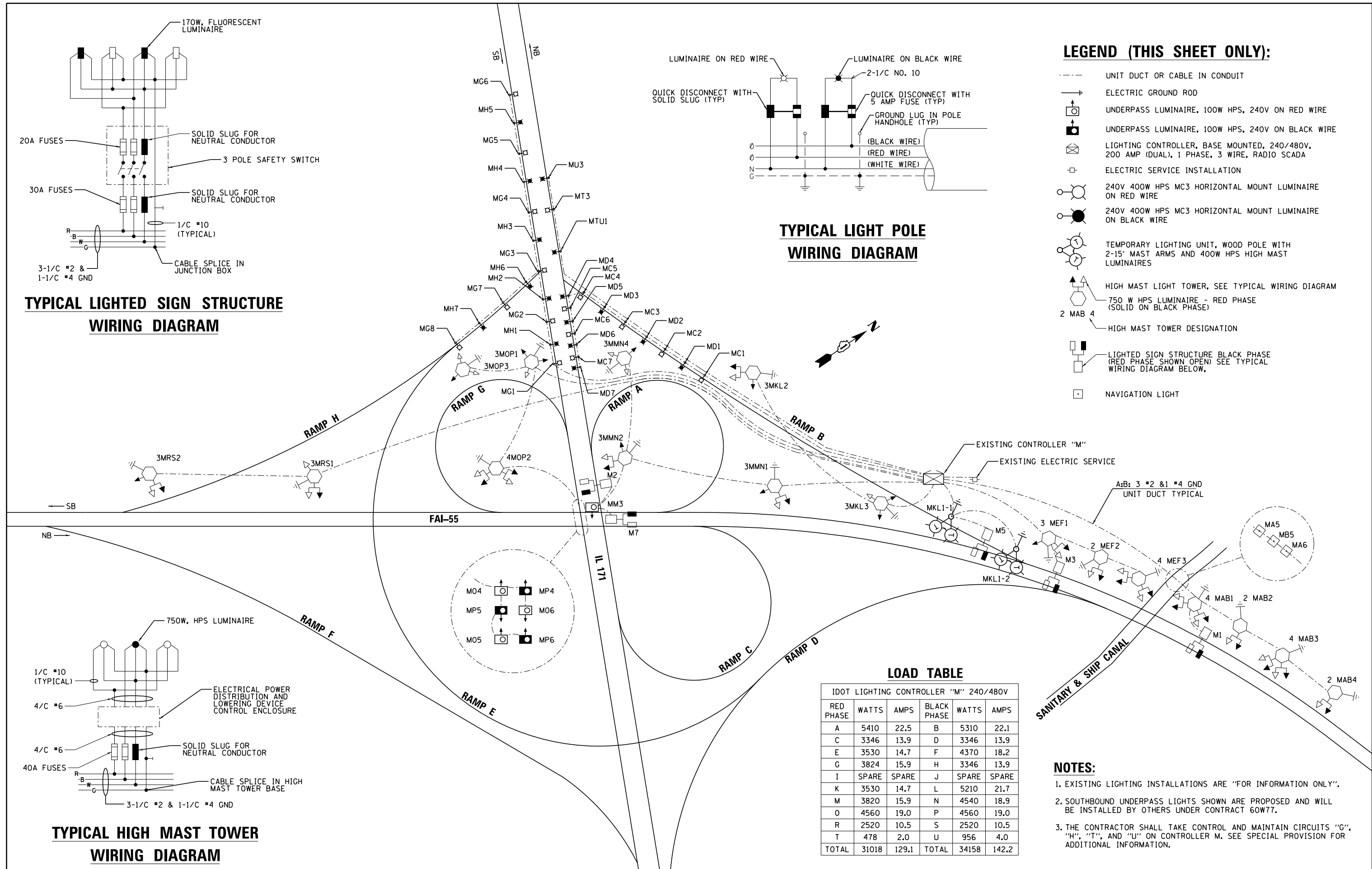

TYPICAL HIGH MAST TOWER WIRING DIAGRAM

LOAD TABLE

IDOT LIGHTING CONTROLLER "M" 240/480V

RED PHASE	WATTS	AMPS	BLACK PHASE	WATTS	AMPS
A	5410	22.5	B	5310	22.1
C	3346	13.9	D	3346	13.9
E	3530	14.7	F	4370	18.2
G	3824	15.9	H	3346	13.9
I	SPARE	SPARE	J	SPARE	SPARE
K	3530	14.7	L	5210	21.7
M	3820	15.9	N	4540	18.9
O	4560	19.0	P	4560	19.0
R	2520	10.5	S	2520	10.5
T	478	2.0	U	956	4.0
TOTAL	31018	129.1	TOTAL	34158	142.2

- NOTES:**
- EXISTING LIGHTING INSTALLATIONS ARE "FOR INFORMATION ONLY".
 - SOUTHBOUND UNDERPASS LIGHTS SHOWN ARE PROPOSED AND WILL BE INSTALLED BY OTHERS UNDER CONTRACT 60W77.
 - THE CONTRACTOR SHALL TAKE CONTROL AND MAINTAIN CIRCUITS "G", "H", "T", AND "U" ON CONTROLLER M. SEE SPECIAL PROVISION FOR ADDITIONAL INFORMATION.

FILE NAME =	DESIGNED - GRR	REVISED -
...\\D160J16-sht-IL171-wiring-01.dgn	DRAWN - JLW	REVISED -
USER NAME = tblank	CHECKED - GHT	REVISED -
PLOT DATE = 8/7/2014	DATE - 6/23/2014	REVISED -



STATE OF ILLINOIS
DEPARTMENT OF TRANSPORTATION

LIGHTING CONTROLLER
"M" WIRING DIAGRAM

SCALE: SHEET 27 OF 49 SHEETS STA. TO STA.

F.A.P. R.T.E.	SECTION	COUNTY	TOTAL SHEETS	SHEET NO.
372/373	2013-038B-R	COOK	821	226
CONTRACT NO. 60J16			ILLINOIS FED. AID PROJECT	