

GENERAL NOTES

All dimensions shall remain the same as shown on superstructure details, except dimensions A and B which are to be revised as shown to provide additional clearance. Additional concrete needed to revise dimension A and B = 0.0165 cu. yds./ft. for 34" parapet or = 0.0223 cu. yds./ft. for 42" parapet. Place aluminum sheet in curb portion at and near piers. Full thickness saw cut at all joint locations in lieu of cork joint filler. Steel superstructure shown. Other superstructure types similar.

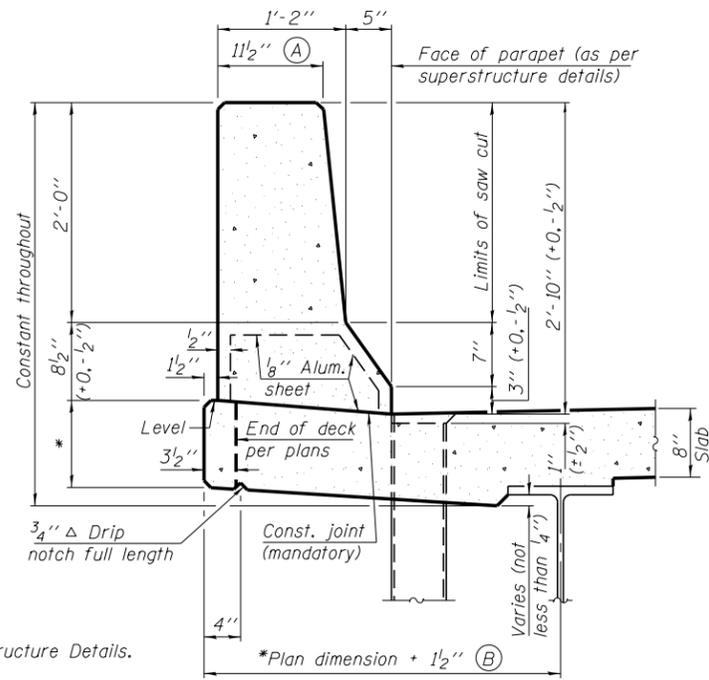

34" F SHAPE PARAPET SECTION
(Showing dimensions)

*See Superstructure Details.

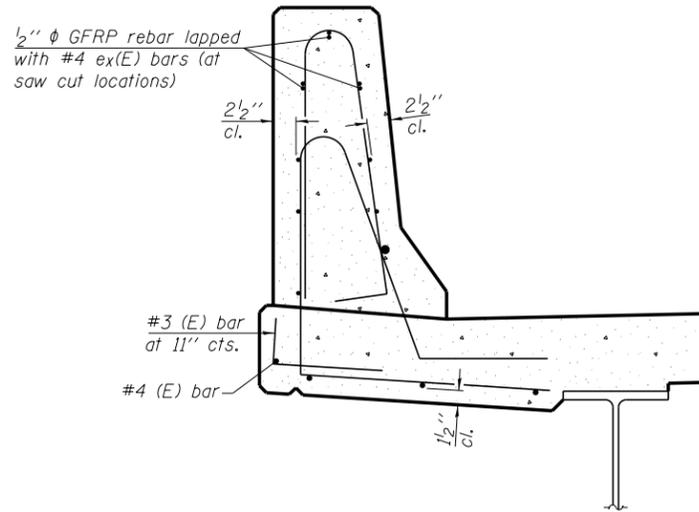

SECTION

(34" parapet shown - 42" parapet similar)
(Showing reinforcement clearances for slip forming and additional reinforcement bars)

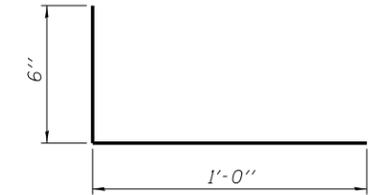

#3 (E) BAR

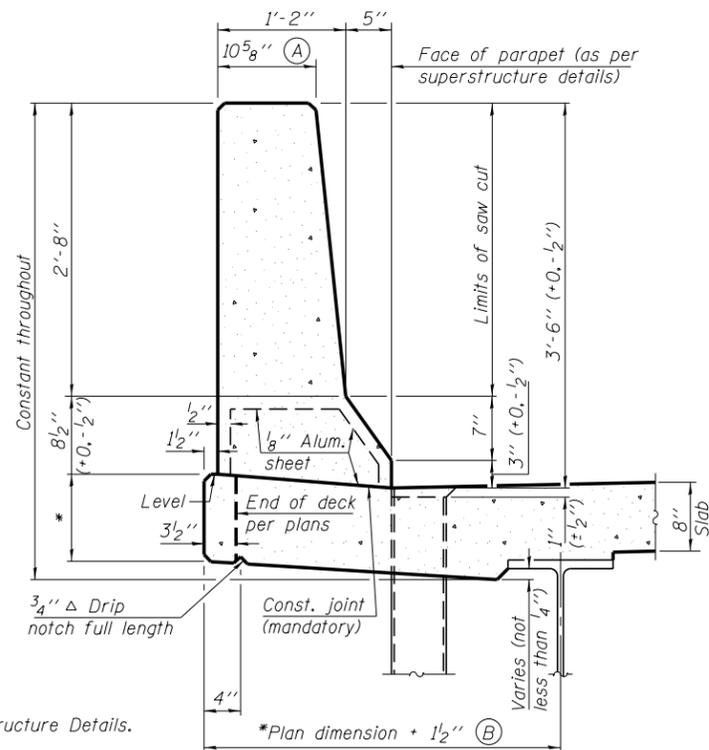

42" F SHAPE PARAPET SECTION
(Showing dimensions)

*See Superstructure Details.

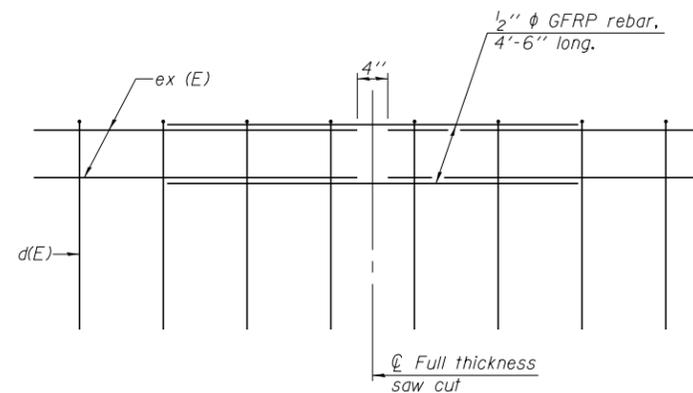

GFRP REBAR STIFFENING DETAIL

(Place as shown in parapet section at each parapet joint location.)

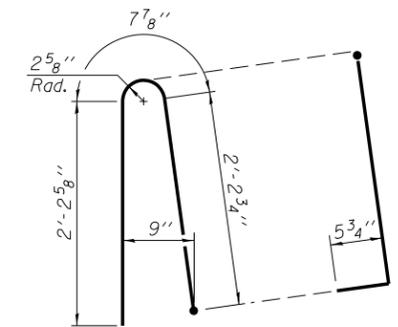

ALTERNATE BAR d(E)

(For 34" parapet when conduit is present)

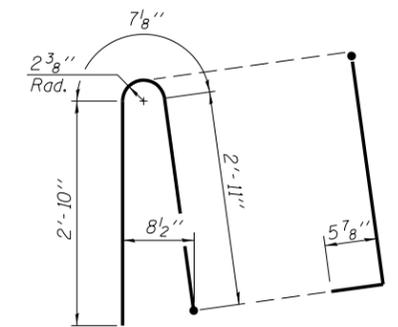

ALTERNATE BAR d(E)

(For 42" parapet when conduit is present)



Alfred Benesch & Company
205 North Michigan Avenue, Suite 2400
Chicago, Illinois 60601
312-565-0450 Job No. 10093

SFP 34-42

8-16-12

FILE NAME =	USER NAME = tjenicke	DESIGNED - JDM	REVISED -
0162455.60J16.017.parapetslipForm.dgn		CHECKED - RDK	REVISED -
	PLOT SCALE =	DRAWN - MAK	REVISED -
	PLOT DATE = 12/20/2013	CHECKED - RDK	REVISED -

**STATE OF ILLINOIS
DEPARTMENT OF TRANSPORTATION**

**CONCRETE PARAPET SLIPFORMING OPTION
STRUCTURE NO. 016-2455**

SHEET NO. SC17 OF SC35 SHEETS

F.A.P. RTE.	SECTION	COUNTY	TOTAL SHEETS	SHEET NO.
372	2013-038B-R	COOK	821	343
CONTRACT NO. 60J16			ILLINOIS FED. AID PROJECT	

X:\1000005\10093\Eng_Docs_Phase_1\1\SN_016_2454_2455_1st_Ave_over_AT&SF_RR\Final\0162455-60J16-017-parapetslipform.dgn 2:36:55 PM 6/23/2014