

PIER 3
Looking East

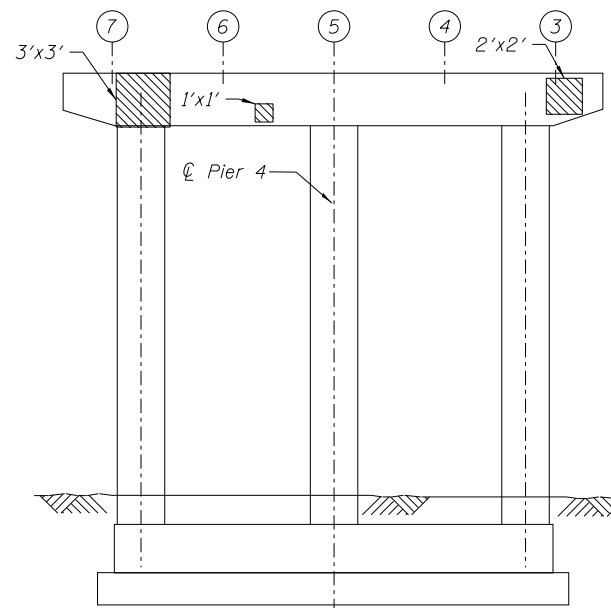

PIER 4
Looking East

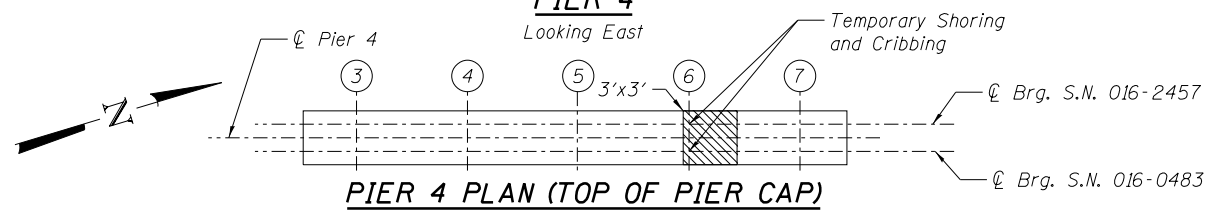

PIER 4 PLAN (TOP OF PIER CAP)

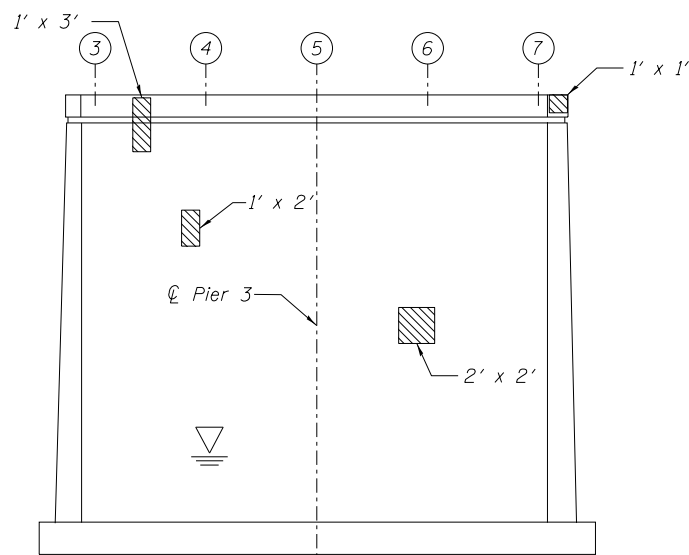

PIER 3
Looking West

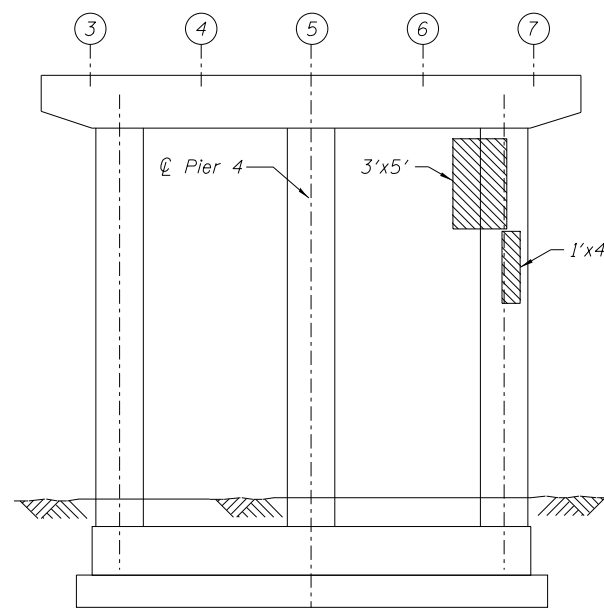

PIER 4
Looking West

LEGEND

Structural Repair of Concrete
(Depth Equal to or Less Than 5 Inches)

BEAM REACTIONS (KIPS)

	Pier 3	Pier 4 016-0483	Pier 4 016-2457
Dead Load (steel only)	41	12	7

BILL OF MATERIAL

ITEM	UNIT	TOTAL
Structural Repair of Concrete (Depth Equal to or Less Than 5 Inches)	Sq. Ft.	57
Temporary Shoring and Cribbing	Each	3

NOTES:

- Actual quantities shall be approved by the Engineer.
- If Temporary Shoring and Cribbing is required to perform a concrete repair, shoring and repair shall be done while the bridge deck is removed.

benesch
engineers · scientists · planners

Alfred Benesch & Company
205 North Michigan Avenue, Suite 2400
Chicago, Illinois 60601
312-565-0450 Job No. 10093

FILE NAME =	USER NAME = jsurber	DESIGNED - TJJ	REVISED -
0160483.60J16.034.Pier.Repair.2.dgn		CHECKED - AJK	REVISED -
	PLOT SCALE =	DRAWN - RMG	REVISED -
	PLOT DATE = 12/20/2013	CHECKED - AJK	REVISED -

STATE OF ILLINOIS
DEPARTMENT OF TRANSPORTATION

PIERS 3 AND 4 CONCRETE REPAIR DETAILS
STRUCTURE NO. 016-0483

SHEET NO. SE34 OF SE46 SHEETS

F.A.P. RTE.	SECTION	COUNTY	TOTAL SHEETS	SHEET NO.
372	2013-038B-R	COOK	821	518
CONTRACT NO. 60J16				

ILLINOIS FED. AID PROJECT

Y:\chicago\100005\100093\Eng_Docs_Phase_1\SN_016_0483_0985_1st_Ave.cover_Des_Plaines_River\Final\0160483-60J16-034_Pier_Repair-2.dgn 5:24:15 PM 8/11/2014