

ROUTE NO.	SECTION	COUNTY	TOTAL SHEETS	SHEET NO.
IL 171	**	COOK	98	221
		ILLINOIS	FED. AID PROJECT	

** SECTION 0707-613B (BR)

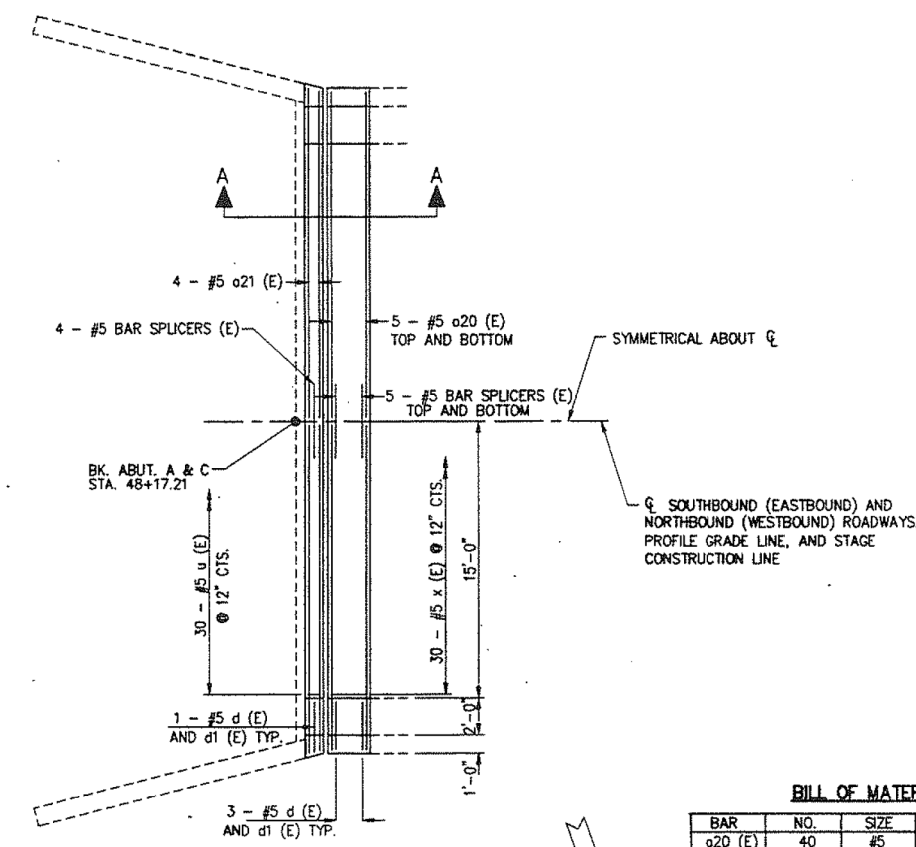

ABUTMENTS A & C - PLAN VIEW

BILL OF MATERIAL

BAR	NO.	SIZE	LENGTH	SHAPE
a20 (E)	40	#5	17'-8"	—
a21 (E)	16	#5	17'-9"	—
d (E)	16	#5	6'-0"	⌈
d1 (E)	16	#5	6'-8"	⌋
u (E)	60	#5	2'-9"	⌈
x (E)	60	#5	2'-7"	⌋
REINFORCEMENT BARS EPOXY COATED.		LBS.	1570	
CONCRETE REMOVAL		C.U. YDS.	10.2	
CLASS X CONCRETE, SUPERSTRUCTURE		C.U. YDS.	10.6	
BAR SPLICERS		EACH	28	
NEOPRENE EXPANSION JOINT 4"		LIN. FT.	73	

REINFORCEMENT BARS DESIGNATED (E) SHALL BE EPOXY COATED.

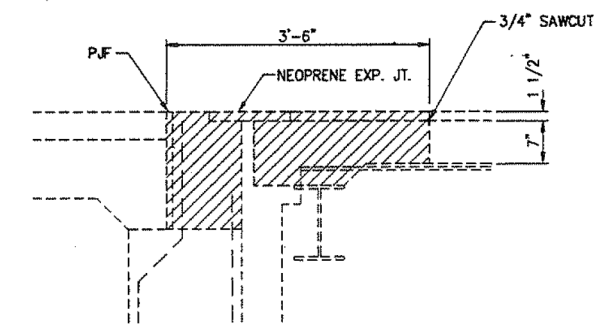

SECTION A-A EXISTING
HATCHED AREAS TO BE REMOVED

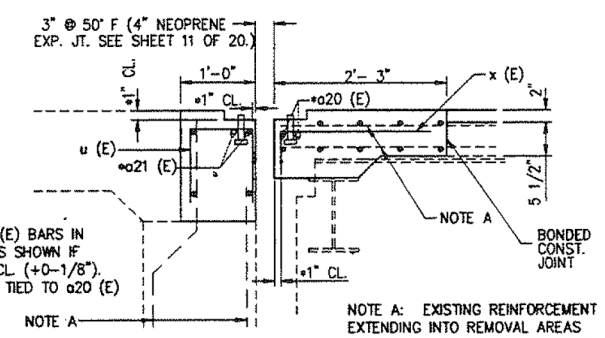

SECTION A-A PROPOSED

PLACE a20 (E) AND a21 (E) BARS IN BACK OF ANCHOR BOLTS AS SHOWN IF REQUIRED TO MAINTAIN 1" CL (+0-1/8"). ANCHOR BOLTS SHOULD BE TIED TO a20 (E) AND a21 (E) BARS.

NOTE A: EXISTING REINFORCEMENT EXTENDING INTO REMOVAL AREAS SHALL BE CLEANED, STRAIGHTENED, AND INCORPORATED INTO THE NEW CONSTRUCTION.

NOTE: COST OF DISASSEMBLY AND REINSTALLATION OF METAL RAIL AND POST WITH NEW ANCHORAGE SHALL BE INCIDENTAL TO CONCRETE REMOVAL.

5/8" THREADED INSERTS PROVIDE 1 - STAINLESS STEEL WASHER AND 1 - 5/8" x 2" STAINLESS STEEL BOLT WITH EACH INSERT. 4 REQUIRED EACH POST.

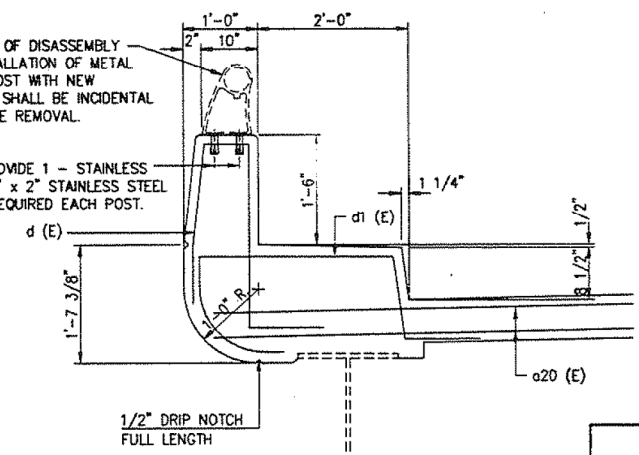

PROPOSED
TYPICAL SECTION AT CURB

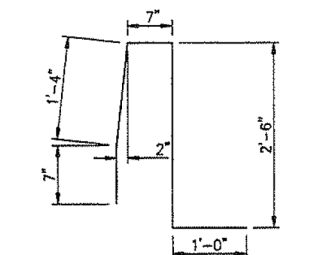

BAR d (E)

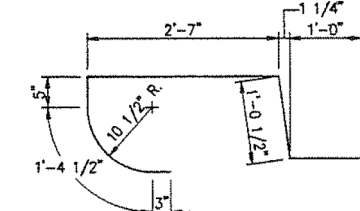

BAR d1 (E)

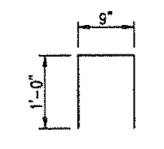

BAR u (E)

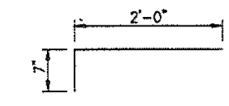

BAR x (E)

ILLINOIS DEPARTMENT OF TRANSPORTATION
NEOPRENE EXPANSION JOINTS
 BRIDGE REPAIRS
 1ST AVE (IL 171) S.N. 016-0483 & 016-0985
 OVER DES PLAINES RIVER
 F.A.U. RT. 1505 SECTION 0707-613B (BR)
 COOK CO: IL
 STA. 50+80.00

12/03/03 11:45:35 AM 483REPAIRS 0483 & 0985 SUBSTRUCTURE REPAIR - JOINTS

1993
 EXAMINED
 ENGINEER OF STRUCTURAL SERVICES
 PASSED
 ENGINEER OF BRIDGE AND STRUCTURES
 APPROVED
 DIRECTOR OF HIGHWAYS

DESIGNED - FSM	REVISED -
CHECKED - RMM	REVISED -
DRAWN - FSM	REVISED -
CHECKED - RMM	REVISED -

FOR INFORMATION ONLY

F.A.P. RTE.	SECTION	COUNTY	TOTAL SHEETS	SHEET NO.
372	2013-038B-R	COOK	821	542
CONTRACT NO. 60J16			ILLINOIS FED. AID PROJECT	