

PIER 43
Looking East

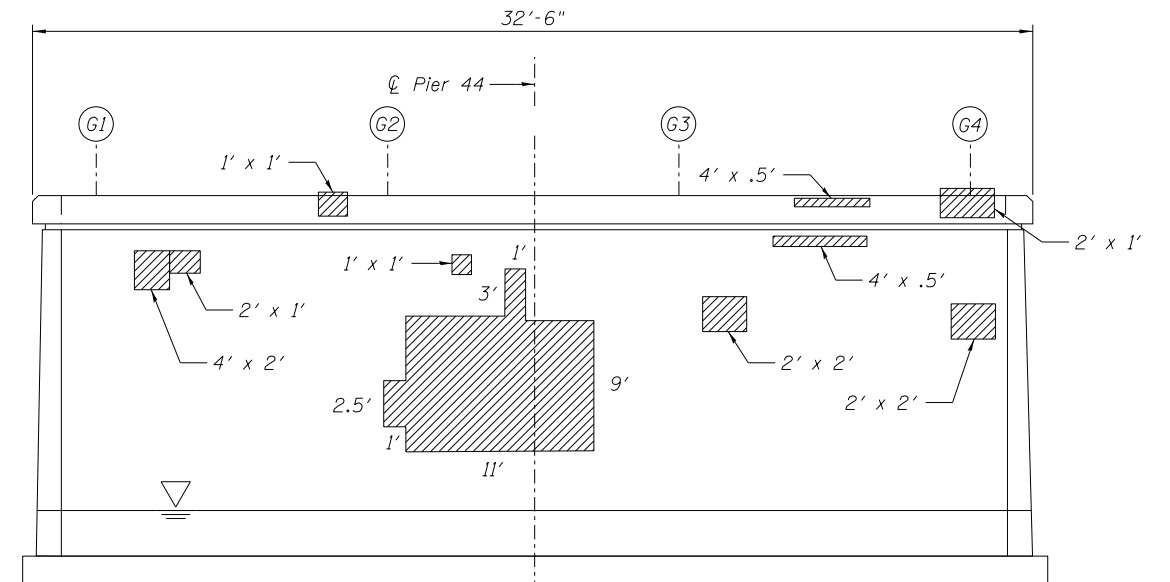

PIER 44
Looking East

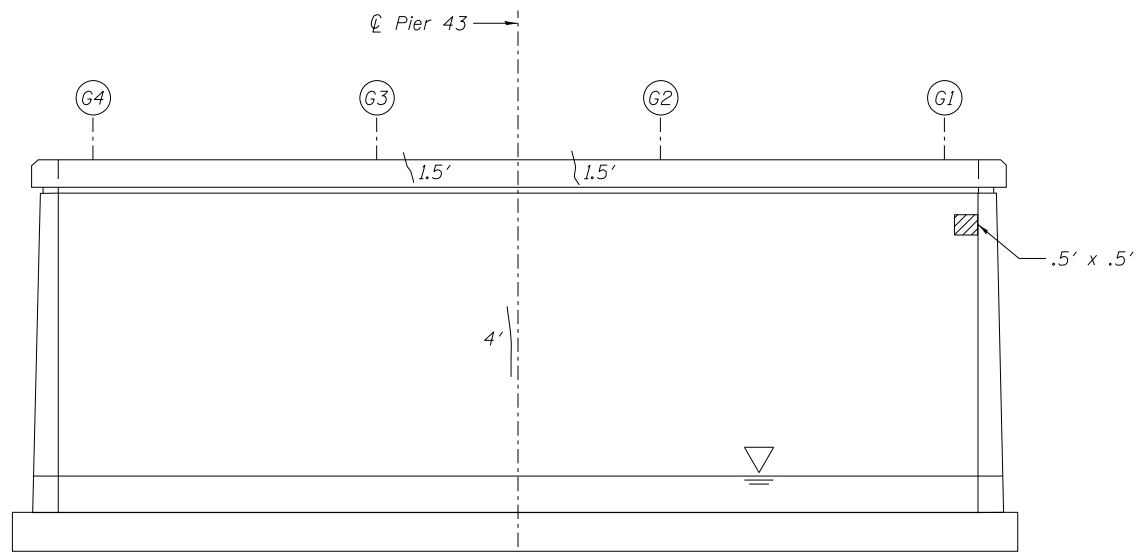

PIER 43
Looking West

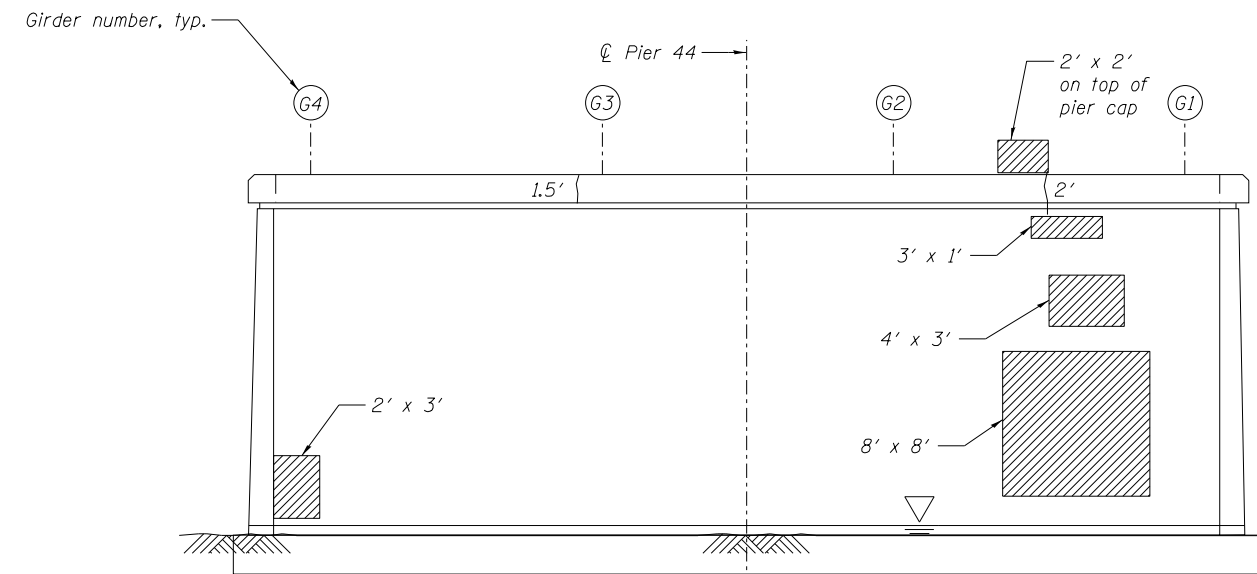

PIER 44
Looking West

LEGEND

Structural Repair of Concrete
(Depth Equal to or Less Than 5 Inches)

Epoxy Crack Injection

NOTE:

Actual quantities of repairs shall be approved by the Engineer.

BILL OF MATERIAL

ITEM	UNIT	TOTAL
Structural Repair of Concrete (Depth Equal to or Less Than 5 Inches)	Sq. Ft.	240
Epoxy Crack Injection	Foot	15

benesch
engineers · scientists · planners
Alfred Benesch & Company
205 North Michigan Avenue, Suite 2400
Chicago, Illinois 60601
312-565-0450 Job No. 10093

FILE NAME =	USER NAME = tjenicke	DESIGNED - JLS	REVISED -
		CHECKED - AJK	REVISED -
		DRAWN - FSM	REVISED -
		CHECKED - AJK	REVISED -
0161026_60J16_015_pierrepair43_44.dgn	PLOT SCALE =		
	PLOT DATE = 12/20/2013		

STATE OF ILLINOIS
DEPARTMENT OF TRANSPORTATION

PIERS 43 AND 44 CONCRETE REPAIR DETAILS
STRUCTURE NO. 016-1026

SHEET NO. SF15 OF SF17 SHEETS

F.A.P. RTE.	SECTION	COUNTY	TOTAL SHEETS	SHEET NO.
372	2013-038B-R	COOK	821	558
CONTRACT NO. 60J16			ILLINOIS FED. AID PROJECT	

X:\1000005\10093\Eng_Docs_Phase_1\1\SN_016_1026_SB_1st_Ave_Ramp_cover_Des_Plaines_River\Final\1026\0161026_60J16_015_pierrepair43_44.dgn 2:45:35 PM 6/23/2014