

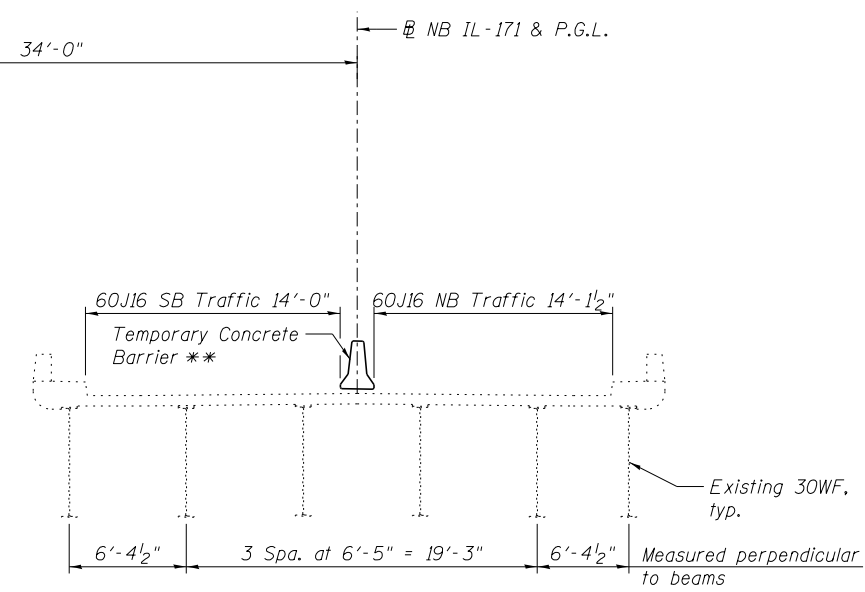

CONTRACT 60J16 REMOVAL
(Spans 8-12 Looking Upstation)

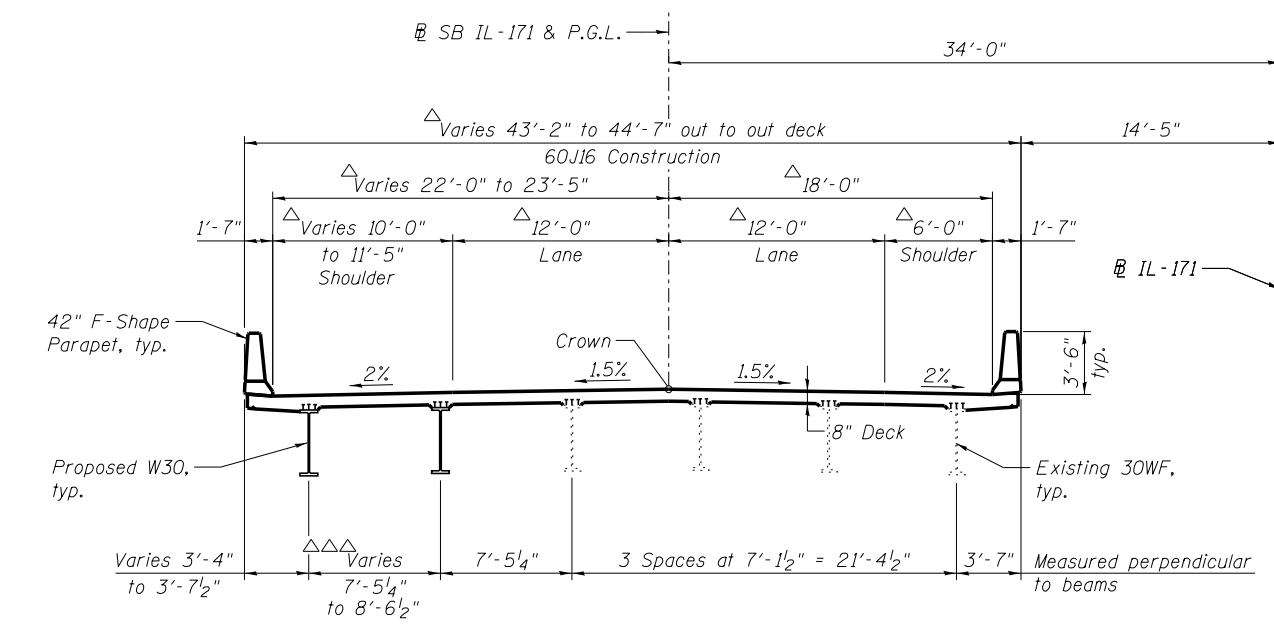

△ Measured perpendicular to IL-171
△△△ Measured perpendicular to Beam D2

CONTRACT 60J16 CONSTRUCTION
(Spans 8-12 Looking Upstation)

LEGEND

 Indicates Removal of Existing Concrete Deck No. 5.

NOTES:

1. All dimensions are measured perpendicular to IL-171 unless noted otherwise.
2. The existing conduit contains live electrical cables that power the existing navigation lighting attached to the fascia girder. Note that the navigation lighting must remain in service without interruption. See Lighting Plans for additional details and requirements. Coordinate the removal of the existing conduit with the installation of the new navigation lighting and corresponding new conduit and wiring. See Sheet SG54 for Conduit Removal Details.
3. Do not anchor Temp. Concrete Barrier to exist. deck.

** See Sheet SG12 and maintenance of traffic sheets for more information.

benesch
engineers · scientists · planners
Alfred Benesch & Company
205 North Michigan Avenue, Suite 2400
Chicago, Illinois 60601
312-565-0450 Job No. 10093

FILE NAME =	USER NAME = jsurber	DESIGNED - FSM	REVISED -
0160486.60J16.011.staging.8thru12.dgn		CHECKED - RMM	REVISED -
	PLOT SCALE =	DRAWN - FSM	REVISED -
	PLOT DATE = 8/6/2014	CHECKED - RMM	REVISED -

STATE OF ILLINOIS
DEPARTMENT OF TRANSPORTATION

STAGE CONSTRUCTION DETAILS SPANS 8 THRU 12
STRUCTURE NO. 016-0486

SHEET NO. SG11 OF SG100 SHEETS

F.A.P. RTE.	SECTION	COUNTY	TOTAL SHEETS	SHEET NO.
373	2013-038B-R	COOK	821	601
CONTRACT NO.			60J16	
ILLINOIS FED. AID PROJECT				

Y:\chicago\100005\100093\Eng_Docs_Phase_1\1\SN_016_0486_0487_1st_Ave.cover_Canal\Final\Final_0486\016_011_staging-8thru12.dgn 7:29:20 PM 8/6/2014