

ROUTE NO.	SECTION	COUNTY	TOTAL SHEETS	SHEET NO.
IL 171	**	COOK	883	272
ILLINOIS			FED. AID PROJECT	

\*\* SECTION 0707-626B (BR)

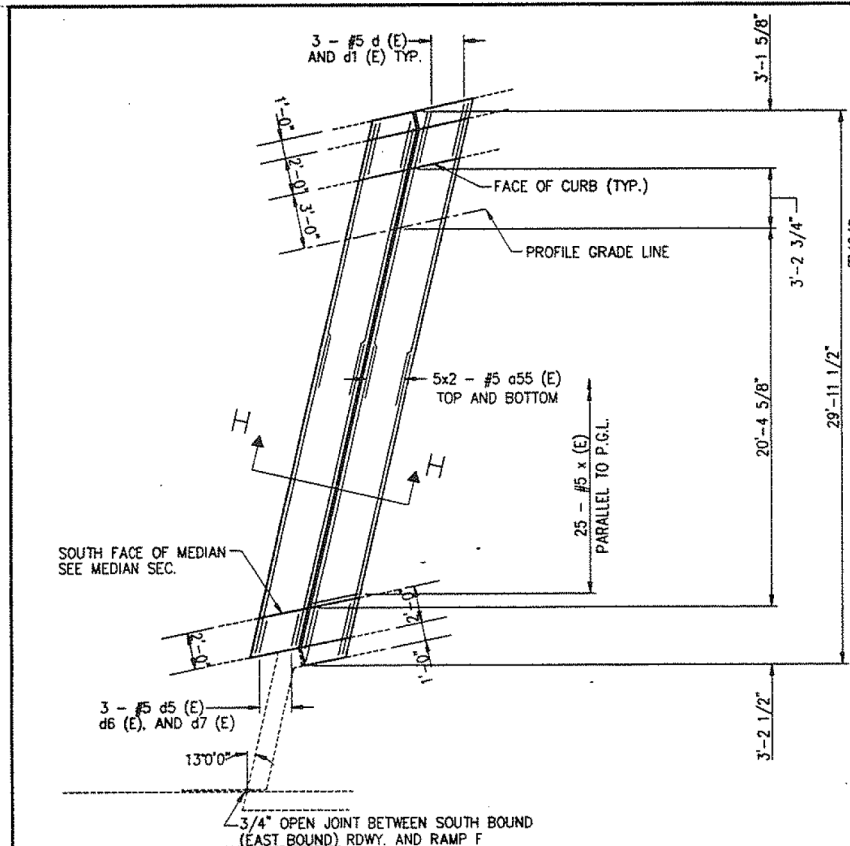

**RAMP F PIER 6**  
NOTE: REINFORCEMENT IS SAME BOTH SIDES OF JOINT EXCEPT AS NOTED

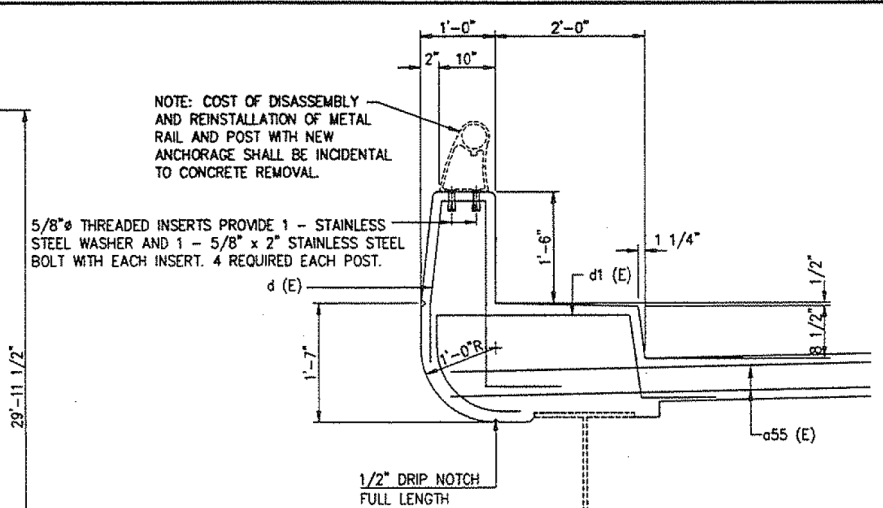

**PROPOSED TYPICAL SECTION AT CURB**

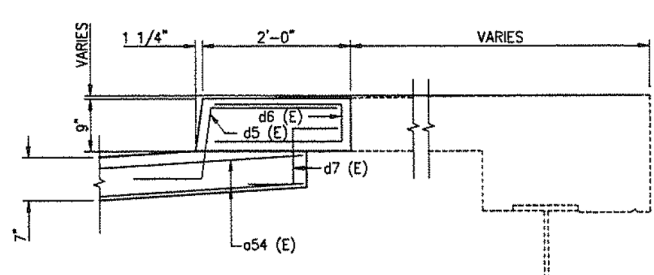

**MEDIAN SECTION**

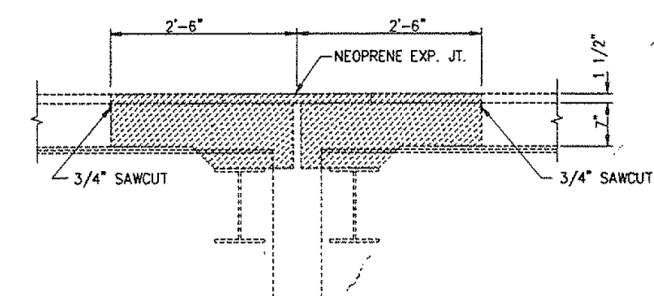

**SECTION H-H EXISTING**  
HATCHED AREAS TO BE REMOVED

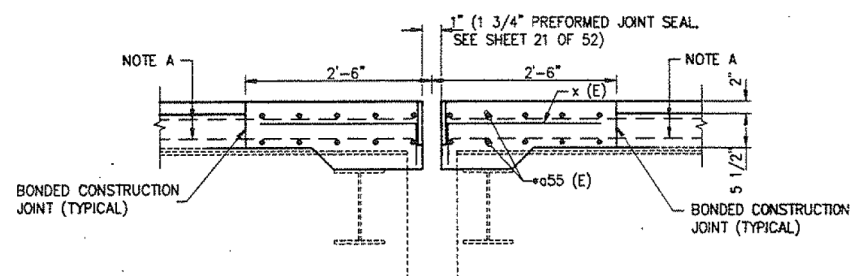

**SECTION H-H PROPOSED**  
NOTE: REINFORCEMENT IS SAME BOTH SIDES OF JOINT

NOTE A: EXISTING REINFORCEMENT EXTENDING INTO REMOVAL AREAS SHALL BE CLEANED, STRAIGHTENED, AND INCORPORATED INTO THE NEW CONSTRUCTION.

**BILL OF MATERIAL**

BAR LIST				
BAR	NO.	SIZE	LENGTH	SHAPE
a55 (E)	40	#5	16'-6"	
d (E)	6	#5	6'-0"	U
d1 (E)	6	#5	6'-8"	U
d5 (E)	6	#5	3'-7"	U
d6 (E)	6	#5	3'-11"	U
d7 (E)	6	#5	1'-11"	U
x (E)	50	#5	2'-7"	U
REINFORCEMENT BARS EPOXY COATED.		LBS.	960	
CONCRETE REMOVAL		C.U. YDS.	5.2	
CLASS X CONCRETE, SUPERSTRUCTURE		C.U. YDS.	5.3	
STRUCTURAL STEEL		POUND	810	
PREFORMED JOINT SEAL 1 3/4"		LN. FT.	32	

REINFORCEMENT BARS DESIGNATED (E) SHALL BE EPOXY COATED.  
BARS INDICATED "5x2 - #5 (ETC)" INDICATES 5 LINES OF BARS WITH 2 LENGTHS PER LINE.

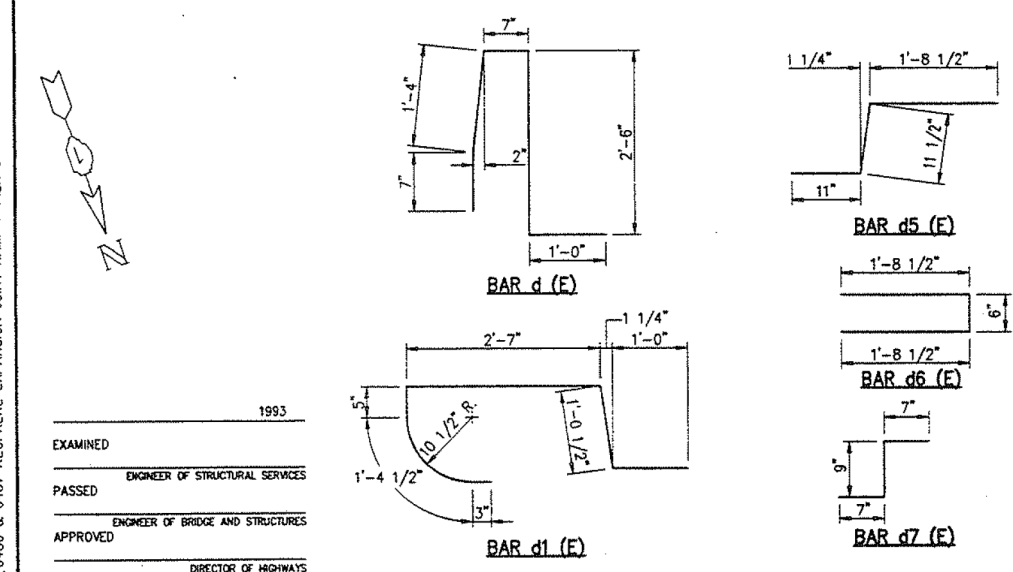

1993  
EXAMINED  
PASSED  
APPROVED  
DIRECTOR OF HIGHWAYS

10/20/03 03:57:04 P.M. P:\SHEPLOW\0466 & 0487\NEOPRENE EXPANSION JOINT RAMP F PIER 6



Alfred Benesch & Company  
205 North Michigan Avenue, Suite 2400  
Chicago, Illinois 60601  
312-565-0450 Job No. 10093

FILE NAME =	USER NAME = tjenicke	DESIGNED - FSM	REVISED -
0160486.60J16.X40.exist.93.rampf6.dgn		CHECKED - RMM	REVISED -
		DRAWN - FSM	REVISED -
		CHECKED - RMM	REVISED -

STATE OF ILLINOIS  
DEPARTMENT OF TRANSPORTATION

EXISTING PLANS (1993) - EXPANSION JOINT RAMP F PIER 6  
STRUCTURE NO. 016-0486

SHEET NO. SGX40 OF SGX48 SHEETS

FOR INFORMATION ONLY

F.A.P. RTE.	SECTION	COUNTY	TOTAL SHEETS	SHEET NO.
373	2013-038B-R	COOK	821	730
			CONTRACT NO. 60J16	
ILLINOIS FED. AID PROJECT				

X:\100005\10093\Eng\_Docs\_Phase\_1\11\SN\_016\_0486\_0487\_1st\_Ave\_cover\_Canal\Final\Final\_0486\0160486\_60J16.X40.exist.93.rampf6.dgn 3:00:22 PM 6/23/2014