

ROUTE NO.	SECTION	COUNTY	TOTAL SHEETS	SHEET NO.
IL 171	**	COOK	583	274
		ILLINOIS	FED. AID PROJECT	

** SECTION 0707-626B (BR)

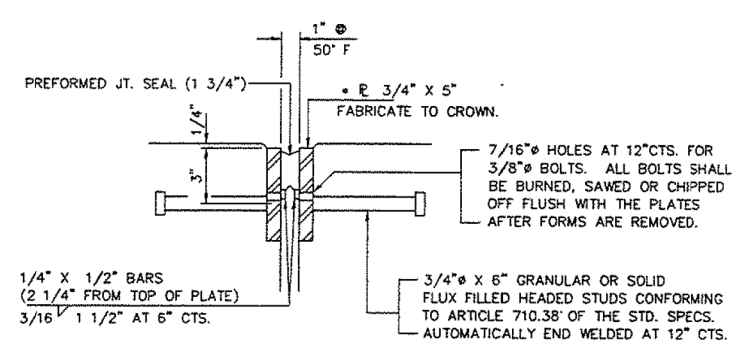

1 3/4" PREFORMED JOINT SEAL DETAIL

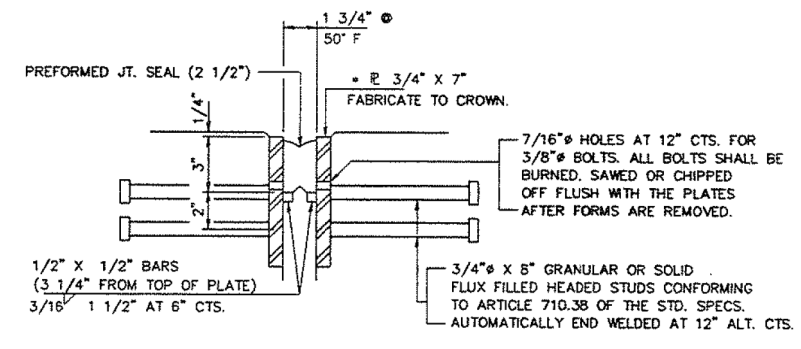

2 1/2" PREFORMED JOINT SEAL DETAIL

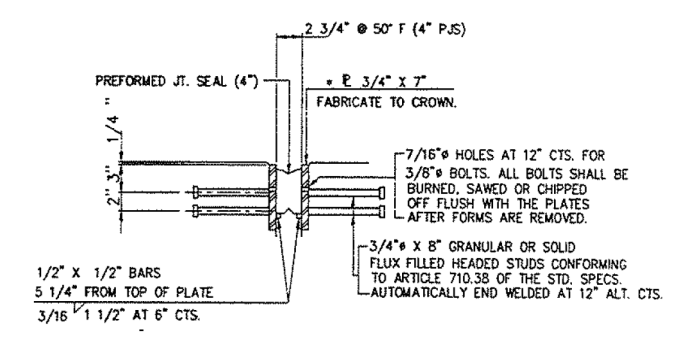

4" PREFORMED JOINT SEAL DETAIL

** FURNISH IN SEGMENTS OF 20 FT. MAXIMUM LENGTH. MAXIMUM SPACE BETWEEN INSTALLED SEGMENTS SHALL BE 3/16". SEAL SPACE WITH SILICONE SEALANT SUITABLE FOR STRUCTURAL STEEL.

NOTES:
AFTER FABRICATION ALL SURFACES OF THE STEEL PLATES SHALL BE GIVEN ONE SHOP COAT OF PAINT SPECIFIED FOR STRUCTURAL STEEL. NO FIELD PAINTING REQUIRED.

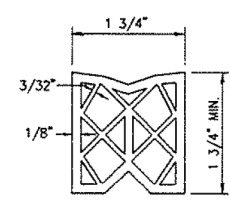

PREFORMED JOINT SEAL (1 3/4")

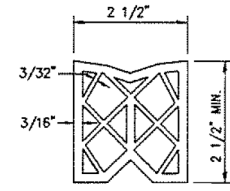

PREFORMED JOINT SEAL (2 1/2")

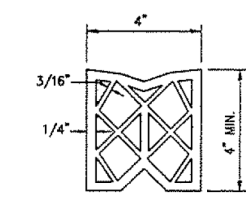

PREFORMED JOINT SEAL (4")

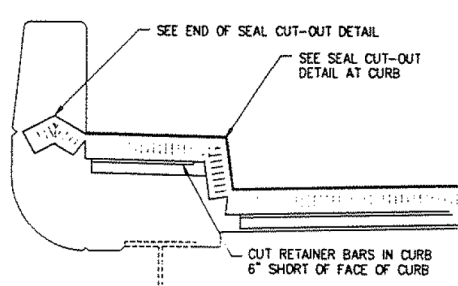

SECTION TYPICAL SEAL TREATMENTS AT CURB
FOR DETAIL OF CURB SEE SHEET 12 OF 52

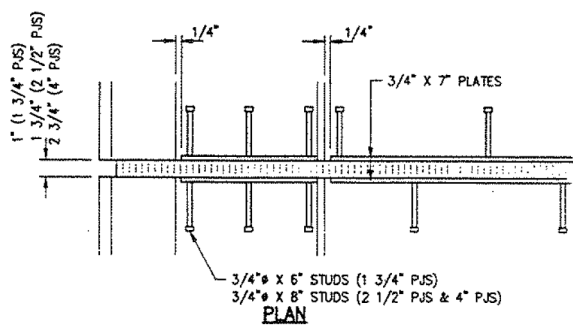

PLAN

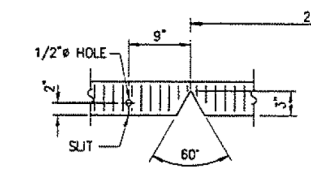

SEAL CUT-OUT @ CURB

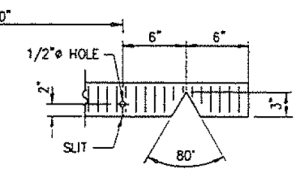

END OF SEAL CUT-OUT

10/27/93 01:13:53 P.M. 486-793.DWG
0486 & 0487 PREFORMED JOINT SEAL DETAILS

1993
EXAMINED
PASSED
APPROVED
DIRECTOR OF HIGHWAYS

ILLINOIS DEPARTMENT OF TRANSPORTATION
PREFORMED JOINT SEAL DETAILS
BRIDGE REPAIRS
1ST AVE (IL 171) S.N. 016-0486 & 016-0487
OVER SANITARY & SHIP CANAL
AND RAMP "E"
SECTION 0707-626B (BR)
F.A.U. RT. 1505
COOK CO. IL
STA. 30+72.59
STA. 35+12.88

benesch
engineers · scientists · planners
Alfred Benesch & Company
205 North Michigan Avenue, Suite 2400
Chicago, Illinois 60601
312-565-0450 Job No. 10093

FILE NAME =	USER NAME = tjenicke	DESIGNED - FSM	REVISED -
0160486.60J16.X42.exist.93.pjsets.dgn		CHECKED - RMM	REVISED -
		DRAWN - FSM	REVISED -
		CHECKED - RMM	REVISED -

**STATE OF ILLINOIS
DEPARTMENT OF TRANSPORTATION**

EXISTING PLANS (1993) - PREFORMED JOINT SEAL DETAILS
STRUCTURE NO. 016-0486

SHEET NO. SGX42 OF SGX48 SHEETS

FOR INFORMATION ONLY

F.A.P. RTE.	SECTION	COUNTY	TOTAL SHEETS	SHEET NO.
373	2013-038B-R	COOK	821	732
			CONTRACT NO. 60J16	
ILLINOIS FED. AID PROJECT				

X:\100005\10093\Eng_Docs_Phase_1\11\SN_016_0486_0487_1st_Ave_over_Canal\Final\Final_0486_0160486_60J16.X42.exist.93.pjsets.dgn 3:00:42 PM 6/23/2014