

SPLICE PLATE

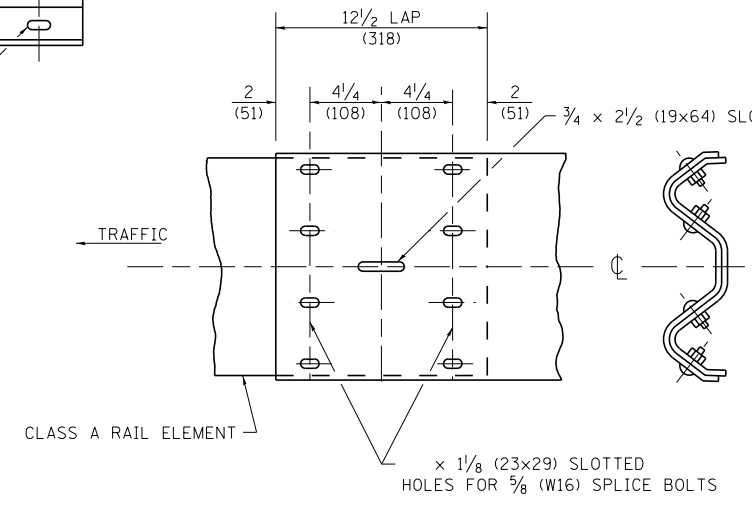

RAIL ELEMENT SPLICE

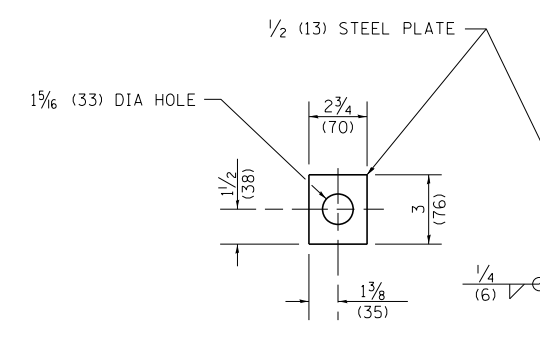

NOTE:

ANCHOR PLATE T SHALL BE USED TO ATTACH CABLE ASSEMBLY TO GUARDRAIL WHEN REQUIRED ON TRAFFIC BARRIER TERMINALS.

ANCHORE PLATE T DETAILS

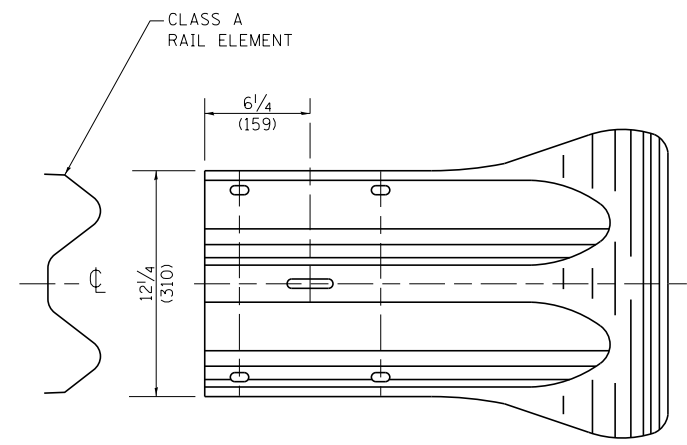
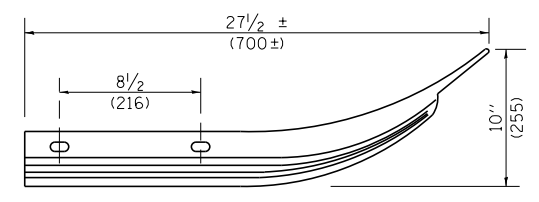
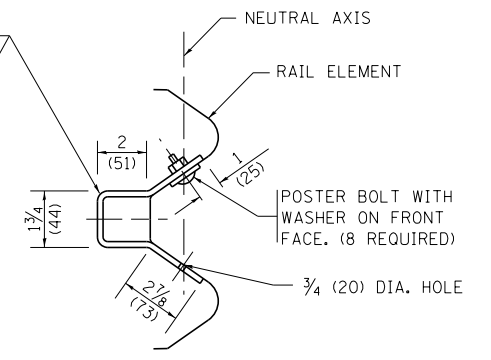

END SECTION

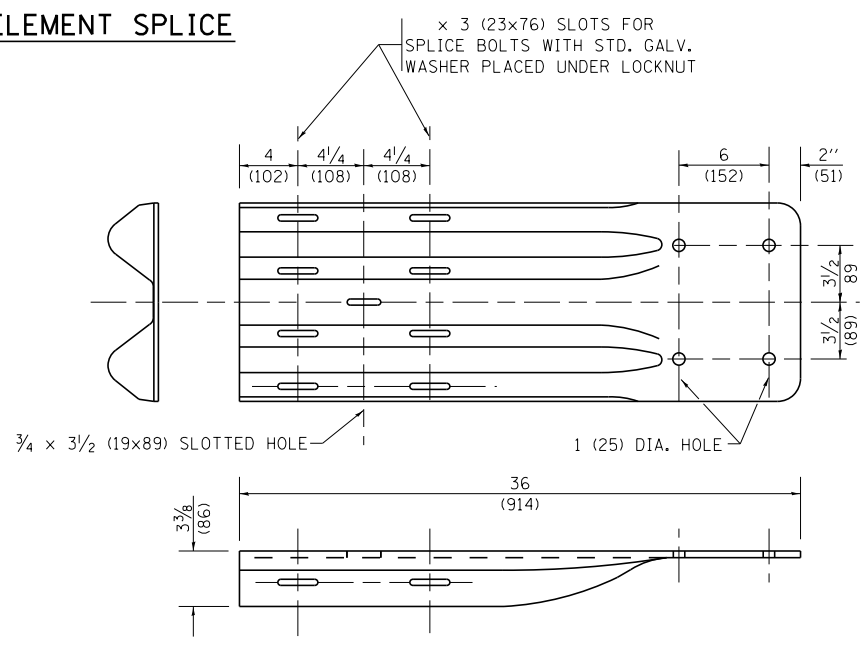

END SHOE

NOTE:

WHEN END SHOE IS ATTACHED TO A BRIDGE PARAPET WHICH HAS AN EXPANSION JOINT, THE BOLTS SHALL BE PROVIDED WITH A LOCKNUT OR DOUBLE NUT AND SHALL BE TIGHTENED ONLY TO A POINT THAT WILL ALLOW GUARDRAIL MOVEMENT.

THE STANDARD END SHOE SHALL BE ATTACHED TO THE CONCRETE WITH PRE-DRILLED OR SELF-DRILLING ANCHOR BOLTS. THE ANCHOR CONE SHALL BE SET FLUSH WITH THE SURFACE OF THE CONCRETE.

EXTERNALLY THREADED STUDS PROTRUDING FROM THE SURFACE OF THE CONCRETE WILL NOT BE PERMITTED.

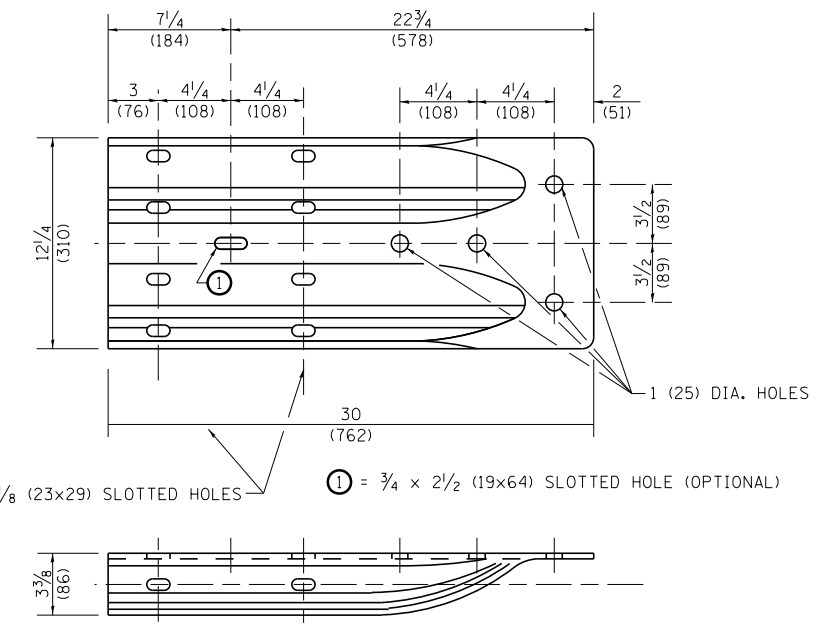

ALTERNATE END SHOE

FILE NAME = ... \D160J16-sht-D1-bm-21c.dgn	USER NAME = tblank	DESIGNED -	REVISED - 10-31-06	STATE OF ILLINOIS DEPARTMENT OF TRANSPORTATION	REMOVE AND REERECT STEEL PLATE BEAM GUARDRAIL			F.A.P. RTE.	SECTION	COUNTY	TOTAL SHEETS	SHEET NO.	
		DRAWN -	REVISED -		SCALE: NONE	SHEET NO. 3	OF 4 SHEETS	STA.	TO STA.	2013-038B-R	COOK	821	798
		CHECKED -	REVISED -							BM-21			
		DATE -	REVISED -							FED. ROAD DIST. NO. 1	ILLINOIS FED. AID PROJECT		CONTRACT NO. 60J16