

## SCHEDULE OF QUANTITIES

| S.P. | CODE NUMBER | DESCRIPTION   | UNIT   | TOTAL QUANTITY |
|------|-------------|---|--------|----------------|
|      | 80300100    | LOCATING UNDERGROUND CABLE  | FOOT   | 10,000         |
| •    | 80400100    | ELECTRIC SERVICE INSTALLATION   | EACH   | 2              |
| •    | 80400200    | ELECTRIC UTILITY SERVICE CONNECTION   | L SUM  | 1              |
| •    | 81028210    | UNDERGROUND CONDUIT, GALVANIZED STEEL, 2 1/2" DIA.                                    | FOOT   | 1,055          |
| •    | 81028240    | UNDERGROUND CONDUIT, GALVANIZED STEEL, 4" DIA.  | FOOT   | 358            |
| •    | 81100320    | CONDUIT ATTACHED TO STRUCTURE, 1" DIA., PVC COATED GALVANIZED STEEL                   | FOOT   | 657            |
| •    | 81100605    | CONDUIT ATTACHED TO STRUCTURE, 2" DIA., PVC COATED GALVANIZED STEEL                   | FOOT   | 191            |
| •    | 81100705    | CONDUIT ATTACHED TO STRUCTURE, 2 1/2" DIA., PVC COATED GALVANIZED STEEL               | FOOT   | 140            |
|      | 81200230    | CONDUIT EMBEDDED IN STRUCTURE, 2" DIA., PVC   | FOOT   | 3,306          |
|      | 81300220    | JUNCTION BOX, STAINLESS STEEL, ATTACHED TO STRUCTURE, 6" X 6" X 4"                    | EACH   | 4              |
|      | 81300550    | JUNCTION BOX, STAINLESS STEEL, ATTACHED TO STRUCTURE, 12" X 12" X 6"                  | EACH   | 20             |
|      | 81300800    | JUNCTION BOX, STAINLESS STEEL, ATTACHED TO STRUCTURE, 18" X 12" X 6"                  | EACH   | 14             |
| •    | 81603030    | UNIT DUCT, 600V, 2-1C NO.4, 1/C NO.6 GROUND, (XLP-TYPE USE), 1" DIA. POLYETHYLENE     | FOOT   | 220            |
| •    | 81603040    | UNIT DUCT, 600V, 2-1C NO.6, 1/C NO.8 GROUND, (XLP-TYPE USE), 1" DIA. POLYETHYLENE     | FOOT   | 2,043          |
| •    | 81603050    | UNIT DUCT, 600V, 3-1C NO.6, 1/C NO.8 GROUND, (XLP-TYPE USE), 1" DIA. POLYETHYLENE     | FOOT   | 5,707          |
| •    | 81603070    | UNIT DUCT, 600V, 2-1C NO.2, 1/C NO.4 GROUND, (XLP-TYPE USE), 1 1/4" DIA. POLYETHYLENE | FOOT   | 454            |
| •    | 81603081    | UNIT DUCT, 600V, 3-1C NO.2, 1/C NO.4 GROUND, (XLP-TYPE USE), 1 1/2" DIA. POLYETHYLENE | FOOT   | 5,756          |
| •    | 81603090    | UNIT DUCT, 600V, 3-1C NO.4, 1/C NO.6 GROUND, (XLP-TYPE USE), 1 1/4" DIA. POLYETHYLENE | FOOT   | 5,066          |
| •    | 81702110    | ELECTRIC CABLE IN CONDUIT, 600V (XLP-TYPE USE) 1/C NO. 10                             | FOOT   | 2,313          |
| •    | 81702130    | ELECTRIC CABLE IN CONDUIT, 600V (XLP-TYPE USE) 1/C NO. 6                              | FOOT   | 207            |
| •    | 81702140    | ELECTRIC CABLE IN CONDUIT, 600V (XLP-TYPE USE) 1/C NO. 4                              | FOOT   | 5,336          |
| •    | 81702150    | ELECTRIC CABLE IN CONDUIT, 600V (XLP-TYPE USE) 1/C NO. 2                              | FOOT   | 13,073         |
| •    | 81702190    | ELECTRIC CABLE IN CONDUIT, 600V(XLP-TYPE USE) 1/C NO. 4/0                             | FOOT   | 525            |
|      | 81800300    | AERIAL CABLE, 3-1/C NO.2 WITH MESSENGER WIRE  | FOOT   | 589            |
| •    | 82102400    | LUMINAIRE, SODIUM VAPOR, HORIZONTAL MOUNT, 400 WATT                                   | EACH   | 101            |
| •    | 82107200    | UNDERPASS LUMINAIRE, 100 WATT, HIGH PRESSURE SODIUM VAPOR                             | EACH   | 8              |
|      | 83050715    | LIGHT POLE, ALUMINUM, 47.5 FT. M.H., 6 FT. DAVIT ARM                                  | EACH   | 16             |
|      | 83050825    | LIGHT POLE, ALUMINUM, 47.5 FT. M.H., 15 FT. DAVIT ARM                                 | EACH   | 83             |
|      | 83057475    | LIGHT POLE, WOOD, 90 FOOT, CLASS 3, WITH 15FT MAST ARM                                | EACH   | 2              |
|      | 83600365    | LIGHT POLE FOUNDATION, METAL, 15" BOLT CIRCLE, 10" X 8"                               | EACH   | 83             |
|      | 83800205    | BREAKAWAY DEVICE, TRANSFORMER BASE, 15 INCH BOLT CIRCLE                               | EACH   | 83             |
|      | 84100110    | REMOVAL OF TEMPORARY LIGHTING UNIT  | EACH   | 1              |
|      | 84200600    | REMOVAL OF LIGHTING UNIT, NO SALVAGE  | EACH   | 100            |
|      | 84200804    | REMOVAL OF POLE FOUNDATION  | EACH   | 78             |
|      | 84301200    | REMOVAL OF NAVIGATION OBSTRUCTION WARNING LIGHTING SYSTEM                             | L SUM  | 1              |
|      | 84500110    | REMOVAL OF LIGHTING CONTROLLER  | EACH   | 2              |
|      | 84500120    | REMOVAL OF ELECTRIC SERVICE INSTALLATION  | EACH   | 2              |
|      | 84500130    | REMOVAL OF LIGHTING CONTROLLER FOUNDATION   | EACH   | 2              |
|      | 89502300    | REMOVE ELECTRIC CABLE FROM CONDUIT  | FOOT   | 4,028          |
| •    | X8130125    | REMOVE EXISTING JUNCTION BOX  | EACH   | 1              |
| •    | X8251388    | LIGHTING CONTROLLER, BASE MOUNTED, 480VOLT, 200AMP (DUAL), RADIO SCADA                | EACH   | 2              |
| •    | X8260110    | NAVIGATION LIGHTING SYSTEM  | L SUM  | 1              |
| •    | X8420502    | REMOVAL OF LIGHT TOWER, NO SALVAGE  | EACH   | 1              |
| •    | X8420510    | REMOVAL OF TOWER FOUNDATION   | EACH   | 2              |
| •    | Z0033020    | LUMINAIRE SAFETY CABLE ASSEMBLY   | EACH   | 101            |
| •    | Z0033028    | MAINTENANCE OF LIGHTING SYSTEM  | CAL MO | 13             |

## UNIT DUCT DESIGNATIONS

THE CONTRACTOR SHALL INSTALL UNIT DUCT ACCORDING TO THE FOLLOWING TABLE:

| LOCATION # | CONTROLLER | CIRCUITS | UNIT DUCT  |
|------------|------------|----------|--|
| L0173      | M          | G & H    | UNIT DUCT, 600V, 3-1/C NO. 2, 1/C NO. 4 GROUND, (XLP-TYPE USE), 1/2" DIA. POLYETHYLENE |
| L0171      | V          | A & B    | UNIT DUCT, 600V, 3-1/C NO. 4, 1/C NO. 6 GROUND, (XLP-TYPE USE), 1/4" DIA. POLYETHYLENE |
| L0171      | V          | C & D    | UNIT DUCT, 600V, 3-1/C NO. 4, 1/C NO. 6 GROUND, (XLP-TYPE USE), 1/4" DIA. POLYETHYLENE |
| L0171      | V          | E & F    | UNIT DUCT, 600V, 3-1/C NO. 4, 1/C NO. 6 GROUND, (XLP-TYPE USE), 1/4" DIA. POLYETHYLENE |
| L0171      | V          | G & H    | UNIT DUCT, 600V, 3-1/C NO. 4, 1/C NO. 6 GROUND, (XLP-TYPE USE), 1/4" DIA. POLYETHYLENE |
| L0177      | Z          | A & B    | UNIT DUCT, 600V, 3-1/C NO. 6, 1/C NO. 8 GROUND, (XLP-TYPE USE), 1" DIA. POLYETHYLENE   |
| L0177      | Z          | C & D    | UNIT DUCT, 600V, 3-1/C NO. 6, 1/C NO. 8 GROUND, (XLP-TYPE USE), 1" DIA. POLYETHYLENE   |
| L0177      | Z          | E & F    | UNIT DUCT, 600V, 3-1/C NO. 2, 1/C NO. 4 GROUND, (XLP-TYPE USE), 1/2" DIA. POLYETHYLENE |
| L0177      | Z          | G & H    | UNIT DUCT, 600V, 3-1/C NO. 2, 1/C NO. 4 GROUND, (XLP-TYPE USE), 1/2" DIA. POLYETHYLENE |
| L0177      | Z          | J & K    | UNIT DUCT, 600V, 3-1/C NO. 6, 1/C NO. 8 GROUND, (XLP-TYPE USE), 1" DIA. POLYETHYLENE   |
| L0177      | Z          | L & M    | UNIT DUCT, 600V, 3-1/C NO. 4, 1/C NO. 6 GROUND, (XLP-TYPE USE), 1/4" DIA. POLYETHYLENE |

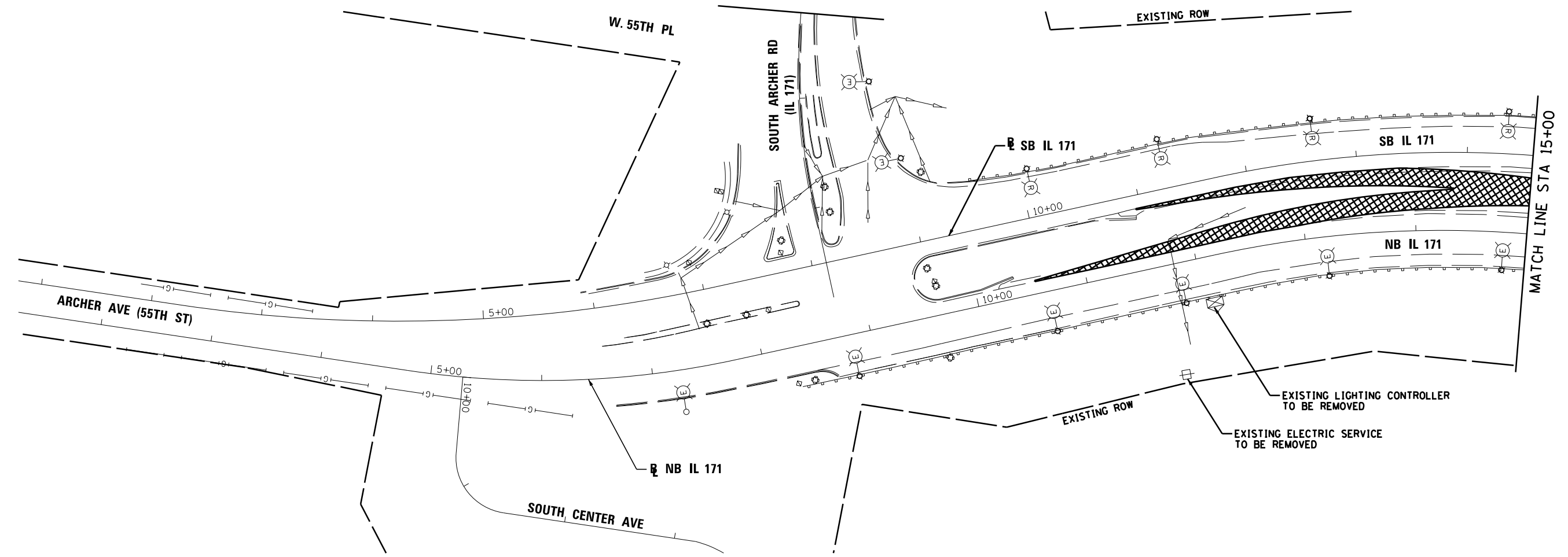

|  |                  |           |
|--|------------------|-----------|
| FILE NAME =                              | DESIGNED - GRR   | REVISED - |
| ...\\D160J16-sht-IL171-exlight-SB-01.dgn | DRAWN - JLW      | REVISED - |
| USER NAME = jworthington                 | CHECKED - GHT    | REVISED - |
| PLOT DATE = 6/23/2014                    | DATE - 6/23/2014 | REVISED - |



**STATE OF ILLINOIS  
DEPARTMENT OF TRANSPORTATION**

**EXISTING LIGHTING REMOVAL &  
TEMPORARY LIGHTING PLAN**

SCALE: SHEET 3 OF 49 SHEETS STA. 10+36.43 TO STA. 15+00.00

| F.A.P. RTE.               | SECTION     | COUNTY | TOTAL SHEETS | SHEET NO.                 |
|---------------------------|-------------|--------|--------------|---------------------------|
| 372/373                   | 2013-038B-R | COOK   | 821          | 202                       |
|                           |             |        |              | <b>CONTRACT NO. 60J16</b> |
| ILLINOIS FED. AID PROJECT |             |        |              |                           |

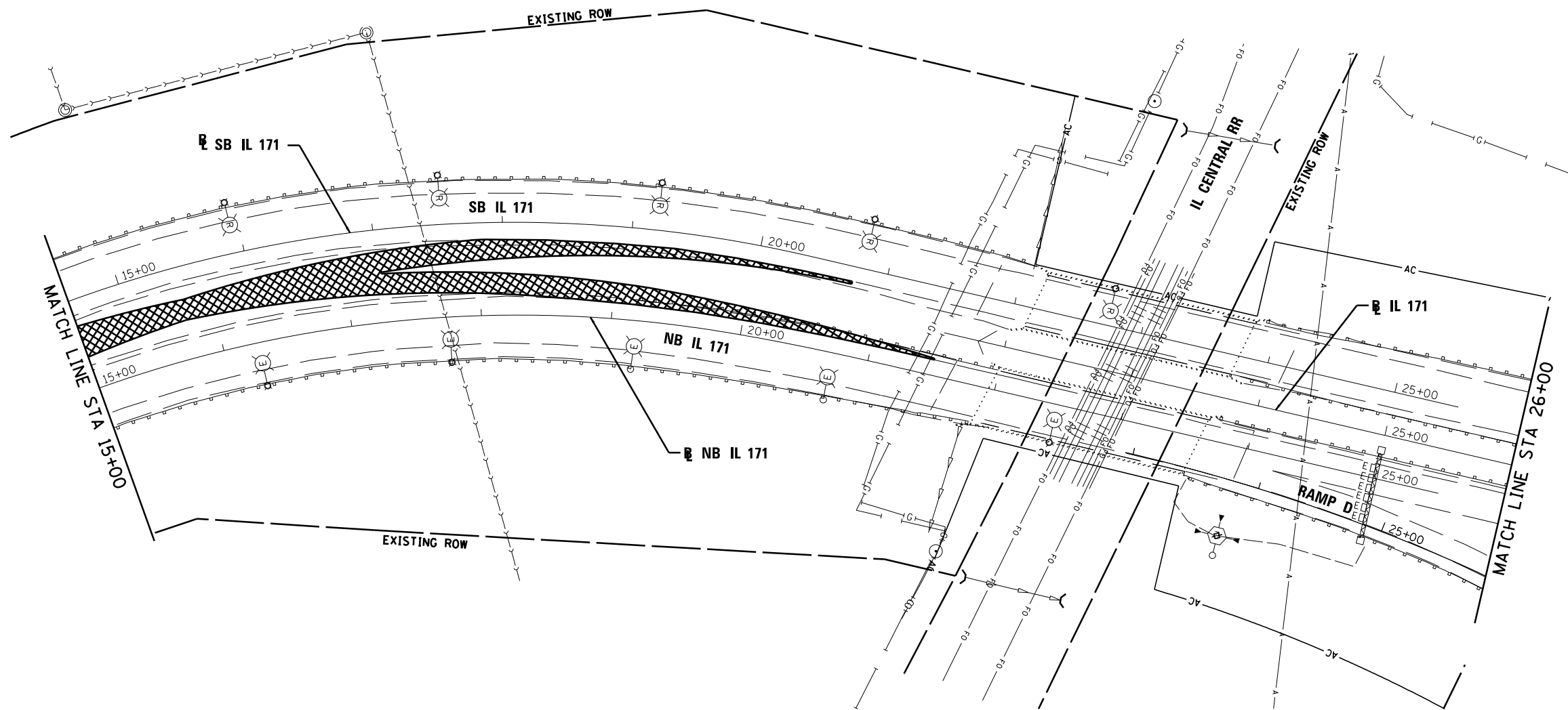

|  |                  |           |
|--|------------------|-----------|
| FILE NAME =                              | DESIGNED - GRR   | REVISED - |
| ...\\D160J16-sht-IL171-exlight-SB-02.dgn | DRAWN - JLW      | REVISED - |
| USER NAME = jworthington                 | CHECKED - GHT    | REVISED - |
| PLOT DATE = 6/23/2014                    | DATE - 6/23/2014 | REVISED - |



STATE OF ILLINOIS  
DEPARTMENT OF TRANSPORTATION

EXISTING LIGHTING REMOVAL &  
TEMPORARY LIGHTING PLAN

SCALE: SHEET 4 OF 49 SHEETS STA. 15+00.00 TO STA. 26+00.00

| F.A.P. RTE.        | SECTION     | COUNTY | TOTAL SHEETS              | SHEET NO. |
|--------------------|-------------|--------|---------------------------|-----------|
| 372/373            | 2013-038B-R | COOK   | 821                       | 203       |
| CONTRACT NO. 60J16 |             |        | ILLINOIS FED. AID PROJECT |           |

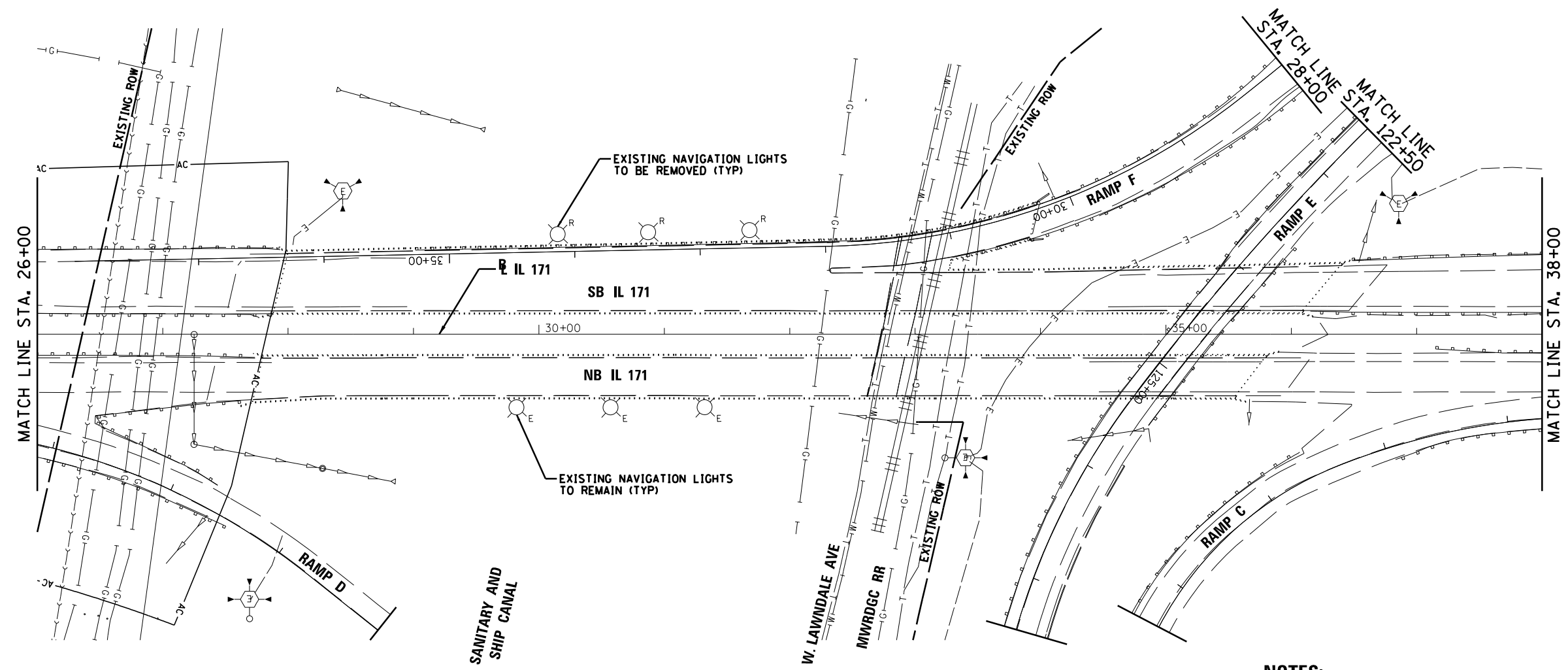

**NOTES:**

1. THE CONTRACTOR'S CONSTRUCTION SEQUENCING SHALL MINIMIZE OUTAGE DURATION OF THE EXISTING NAVIGATION LIGHTING.
2. THE CONTRACTOR SHALL NOTIFY THE UNITED STATES COAST GUARD NORTH DISTRICT, MR. LEE SOULE, PHONE # 216-902-6085, TWO WEEKS PRIOR TO ANY PLANNED NAVIGATION LIGHTING OUTAGE.
3. THE CONTRACTOR SHALL FURNISH AND INSTALL TEMPORARY BATTERY OPERATED LED NAVIGATION LIGHTS IN PLACE OF THE EXISTING LIGHTS THAT WILL BE OUT OF SERVICE. THE TEMPORARY LIGHTS SHALL CONFORM TO ALL UNITED STATES COAST GUARD GUIDELINES AND STANDARDS FOR BRIDGE LIGHTING.
4. THE LIGHTS SHALL MATCH THE COLOR, INTENSITY, AND DISTRIBUTION OF THE EXISTING NAVIGATION LIGHTS. TEMPORARY LIGHTS SHALL BE IN SERVICE WHENEVER THE EXISTING LIGHTS ARE OUT OF SERVICE. THE COST OF TEMPORARY LED NAVIGATION LIGHTS SHALL BE INCLUDED IN THE PRICE OF THE ITEM "NAVIGATION LIGHTING SYSTEM".

|  |                  |           |
|--|------------------|-----------|
| FILE NAME =                              | DESIGNED - GRR   | REVISED - |
| ...\\D160J16-sht-IL171-exlight-SB-03.dgn | DRAWN - JLW      | REVISED - |
| USER NAME = jworthington                 | CHECKED - GHT    | REVISED - |
| PLOT DATE = 6/23/2014                    | DATE - 6/23/2014 | REVISED - |



STATE OF ILLINOIS  
DEPARTMENT OF TRANSPORTATION

EXISTING LIGHTING REMOVAL &  
TEMPORARY LIGHTING PLAN

SCALE: SHEET 5 OF 49 SHEETS STA. 26+00.00 TO STA. 38+00.00

|                    |             |        |                           |           |
|--------------------|-------------|--------|---------------------------|-----------|
| F.A.P. RTE.        | SECTION     | COUNTY | TOTAL SHEETS              | SHEET NO. |
| 372/373            | 2013-038B-R | COOK   | 821                       | 204       |
| CONTRACT NO. 60J16 |             |        | ILLINOIS FED. AID PROJECT |           |



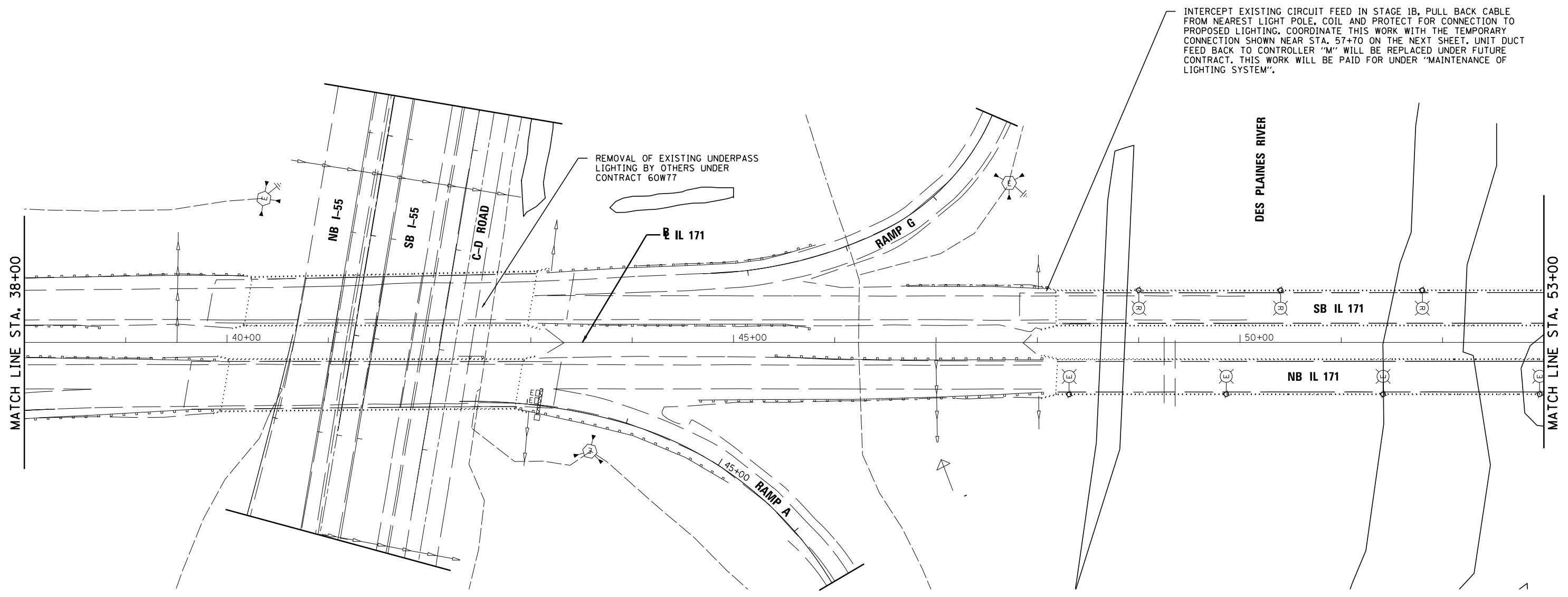

|  |                  |           |
|--|------------------|-----------|
| FILE NAME =                              | DESIGNED - GRR   | REVISED - |
| ...\\D160J16-sht-IL171-exlight-SB-04.dgn | DRAWN - JLW      | REVISED - |
| USER NAME = jworthington                 | CHECKED - GHT    | REVISED - |
| PLOT DATE = 6/23/2014                    | DATE - 6/23/2014 | REVISED - |



**STATE OF ILLINOIS  
DEPARTMENT OF TRANSPORTATION**

**EXISTING LIGHTING REMOVAL &  
TEMPORARY LIGHTING PLAN**

SCALE: SHEET 6 OF 49 SHEETS STA. 38+00.00 TO STA. 53+00.00

| F.A.P. RTE.        | SECTION     | COUNTY | TOTAL SHEETS              | SHEET NO. |
|--------------------|-------------|--------|---------------------------|-----------|
| 372/373            | 2013-038B-R | COOK   | 821                       | 205       |
| CONTRACT NO. 60J16 |             |        | ILLINOIS FED. AID PROJECT |           |

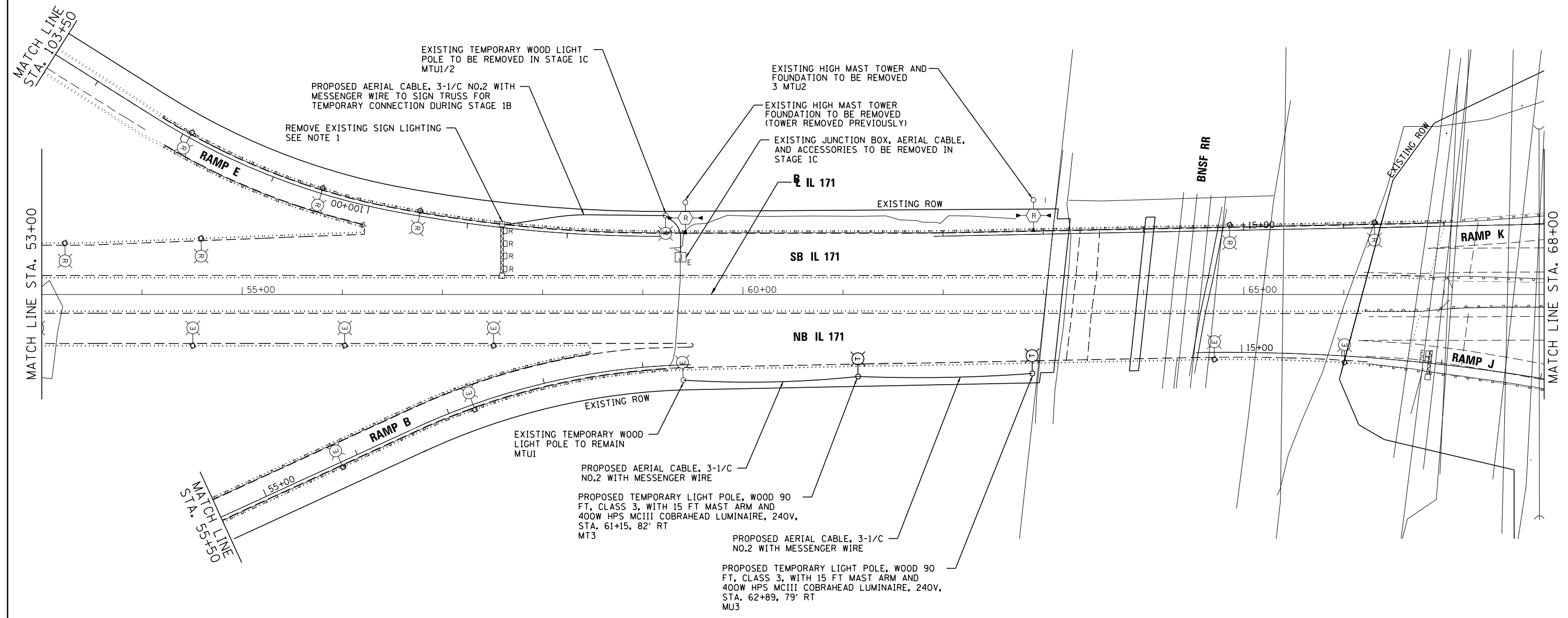

**NOTES:**

1. REMOVAL OF SIGN LIGHTING SHALL BE PAID FOR AS "REMOVAL OF LIGHTING UNIT, NO SALVAGE" REGARDLESS OF THE NUMBER OF INDIVIDUAL SIGN LUMINAIRES.
2. REMOVAL OF AERIAL CABLE SHALL BE INCLUDED IN THE COST OF THE TEMPORARY LIGHTING UNIT.

|  |                  |           |
|--|------------------|-----------|
| FILE NAME =                              | DESIGNED - GRR   | REVISED - |
| ...\\D160J16-sht-IL171-exlight-SB-05.dgn | DRAWN - JLW      | REVISED - |
| USER NAME = tblank                       | CHECKED - GHT    | REVISED - |
| PLOT DATE = 8/7/2014                     | DATE - 6/23/2014 | REVISED - |



**STATE OF ILLINOIS  
DEPARTMENT OF TRANSPORTATION**

**EXISTING LIGHTING REMOVAL &  
TEMPORARY LIGHTING PLAN**

SCALE: SHEET 7 OF 49 SHEETS STA. 53+00.00 TO STA. 68+00.00

|                           |             |        |              |           |
|---------------------------|-------------|--------|--------------|-----------|
| F.A.P. RTE.               | SECTION     | COUNTY | TOTAL SHEETS | SHEET NO. |
| 372/373                   | 2013-038B-R | COOK   | 821          | 206       |
| CONTRACT NO.              |             |        | 60J16        |           |
| ILLINOIS FED. AID PROJECT |             |        |              |           |

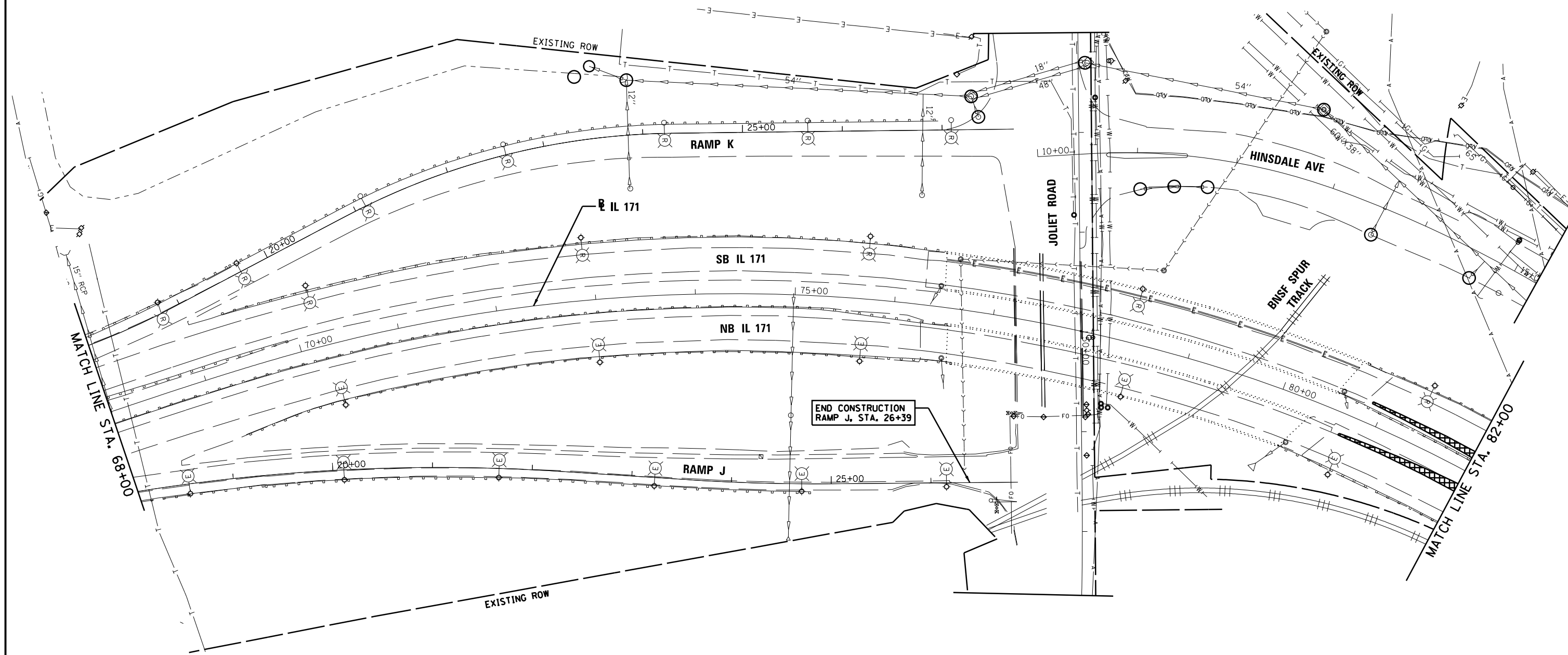
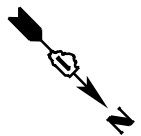

END CONSTRUCTION  
RAMP J, STA. 26+39

|  |                  |           |
|--|------------------|-----------|
| FILE NAME =                              | DESIGNED - GRR   | REVISED - |
| ...\\D160J16-sht-IL171-exlight-SB-06.dgn | DRAWN - JLW      | REVISED - |
| USER NAME = jworthington                 | CHECKED - GHT    | REVISED - |
| PLOT DATE = 6/23/2014                    | DATE - 6/23/2014 | REVISED - |



STATE OF ILLINOIS  
DEPARTMENT OF TRANSPORTATION

EXISTING LIGHTING REMOVAL &  
TEMPORARY LIGHTING PLAN

SCALE: SHEET 8 OF 49 SHEETS STA. 68+00.00 TO STA. 82+00.00

| F.A.P. RTE.        | SECTION     | COUNTY | TOTAL SHEETS              | SHEET NO. |
|--------------------|-------------|--------|---------------------------|-----------|
| 372/373            | 2013-038B-R | COOK   | 821                       | 207       |
| CONTRACT NO. 60J16 |             |        | ILLINOIS FED. AID PROJECT |           |

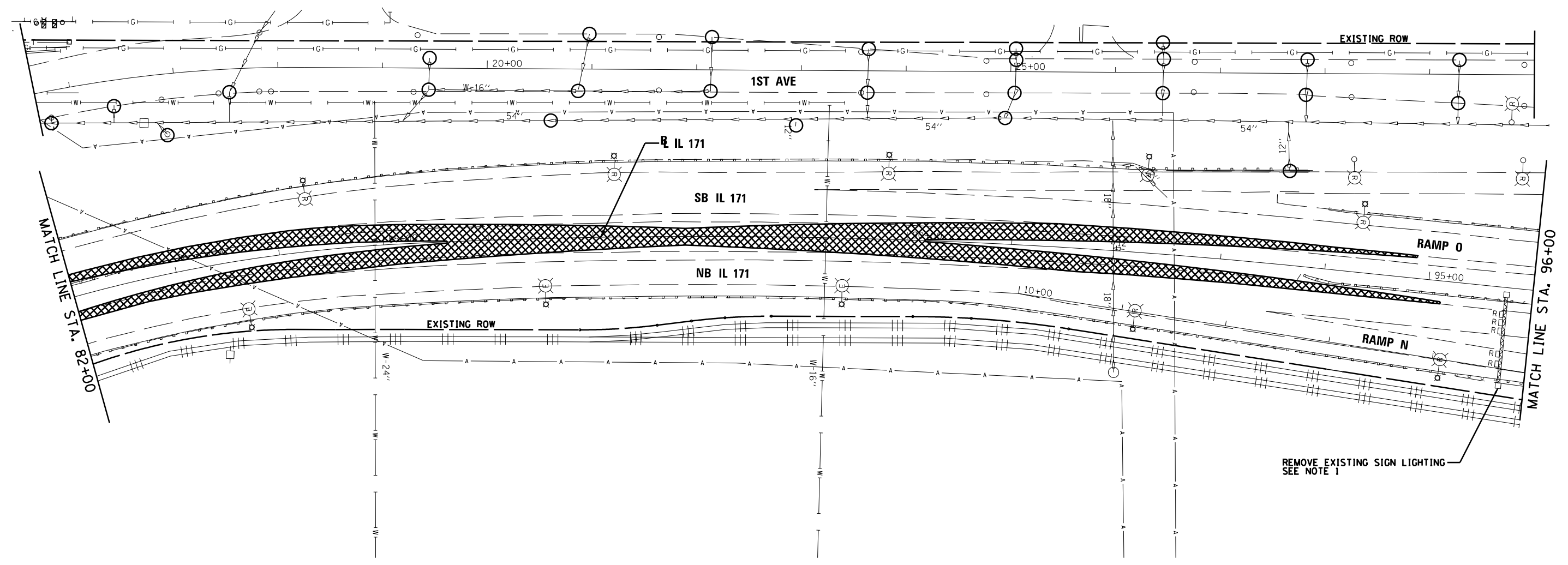

**NOTE:**  
 1. REMOVAL OF EXISTING SIGN LIGHTING SHALL BE PAID FOR AS "REMOVAL OF LIGHTING UNIT, NO SALVAGE" REGARDLESS OF THE NUMBER OF INDIVIDUAL LUMINAIRES.

|  |                |           |  |   |  |  |  |  |                     |             |                    |               |  |
|--|----------------|-----------|--|---|--|--|--|--|---------------------|-------------|--------------------|---------------|--|
| FILE NAME = ... \D160J16-sht-IL171-exlight-SB-07.dgn | DESIGNED - GRR | REVISED - |  | <b>STATE OF ILLINOIS</b><br><b>DEPARTMENT OF TRANSPORTATION</b> | <b>EXISTING LIGHTING REMOVAL &amp; TEMPORARY LIGHTING PLAN</b> |  |  | F.A.P. RTE. 372/373  | SECTION 2013-038B-R | COUNTY COOK | TOTAL SHEETS 821   | SHEET NO. 208 |  |
| USER NAME = jworthington                             | DRAWN - JLW    | REVISED - |  |   |  |  |  | SCALE: SHEET 9 OF 49 SHEETS STA. 82+00.00 TO STA. 96+00.00 |                     |             | CONTRACT NO. 60J16 |               |  |
| PLOT DATE = 6/23/2014                                | CHECKED - GHT  | REVISED - |  |   | ILLINOIS FED. AID PROJECT                                      |  |  |  |                     |             |                    |               |  |
| DATE - 6/23/2014                                     | REVISIONS      | REVISIONS |  |   |  |  |  |  |                     |             |                    |               |  |

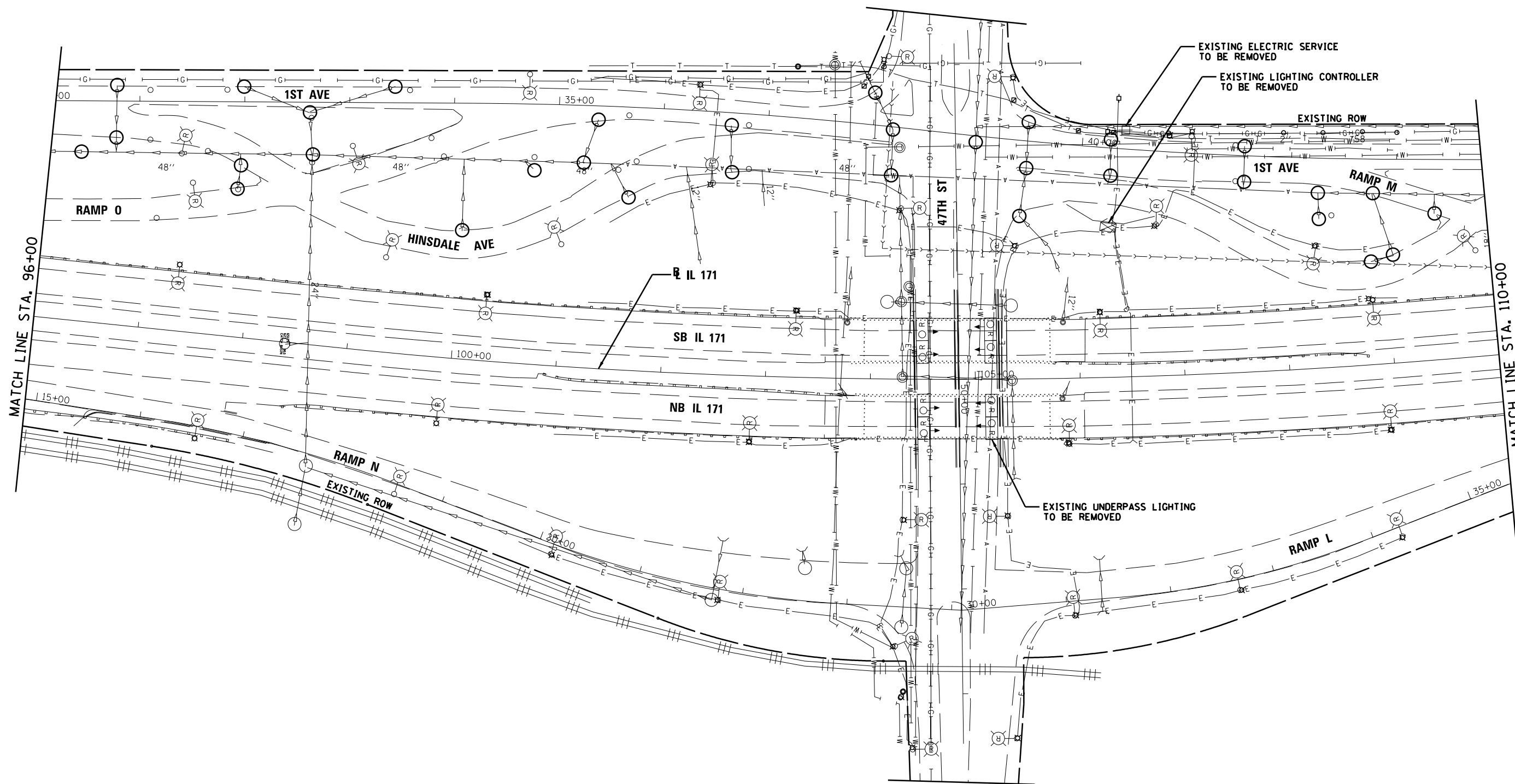

|  |                  |           |
|--|------------------|-----------|
| FILE NAME =                              | DESIGNED - GRR   | REVISED - |
| ...\\D160J16-sht-IL171-exlight-SB-08.dgn | DRAWN - JLW      | REVISED - |
| USER NAME = jworthington                 | CHECKED - GHT    | REVISED - |
| PLOT DATE = 6/23/2014                    | DATE - 6/23/2014 | REVISED - |



STATE OF ILLINOIS  
DEPARTMENT OF TRANSPORTATION

EXISTING LIGHTING REMOVAL &  
TEMPORARY LIGHTING PLAN

SCALE: SHEET 10 OF 49 SHEETS STA. 96+00.00 TO STA. 110+00.00

| F.A.P. RTE.        | SECTION     | COUNTY | TOTAL SHEETS              | SHEET NO. |
|--------------------|-------------|--------|---------------------------|-----------|
| 372/373            | 2013-038B-R | COOK   | 821                       | 209       |
| CONTRACT NO. 60J16 |             |        | ILLINOIS FED. AID PROJECT |           |

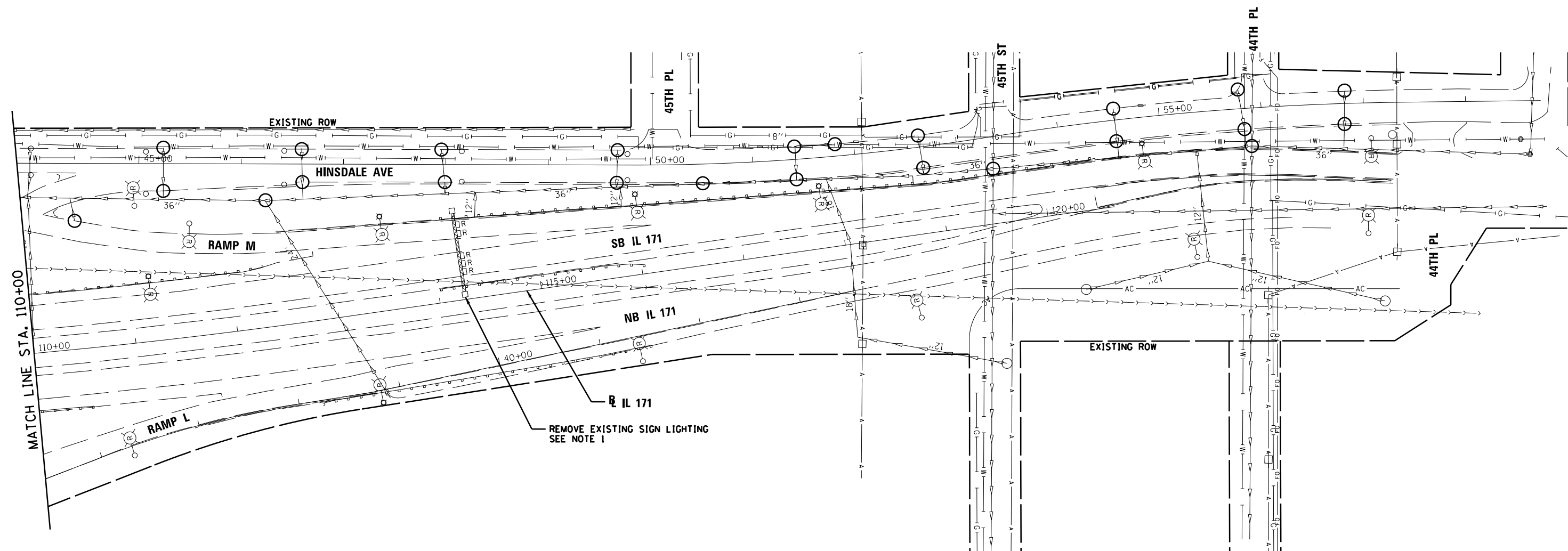

**NOTE:**

1. REMOVAL OF EXISTING SIGN LIGHTING SHALL BE PAID FOR AS "REMOVAL OF LIGHTING UNIT, NO SALVAGE" REGARDLESS OF THE NUMBER OF INDIVIDUAL LUMINAIRES.

|  |                  |           |
|--|------------------|-----------|
| FILE NAME =                              | DESIGNED - GRR   | REVISED - |
| ... \D160J16-sht-IL171-exlight-SB-09.dgn | DRAWN - JLW      | REVISED - |
| USER NAME = jworthington                 | CHECKED - GHT    | REVISED - |
| PLOT DATE = 6/23/2014                    | DATE - 6/23/2014 | REVISED - |



STATE OF ILLINOIS  
DEPARTMENT OF TRANSPORTATION

**EXISTING LIGHTING REMOVAL &  
TEMPORARY LIGHTING PLAN**

SCALE: SHEET 11 OF 49 SHEETS STA. 110+00.00 TO STA. 117+74.96

| F.A.P. RTE.        | SECTION     | COUNTY | TOTAL SHEETS              | SHEET NO. |
|--------------------|-------------|--------|---------------------------|-----------|
| 372/373            | 2013-038B-R | COOK   | 821                       | 210       |
| CONTRACT NO. 60J16 |             |        | ILLINOIS FED. AID PROJECT |           |

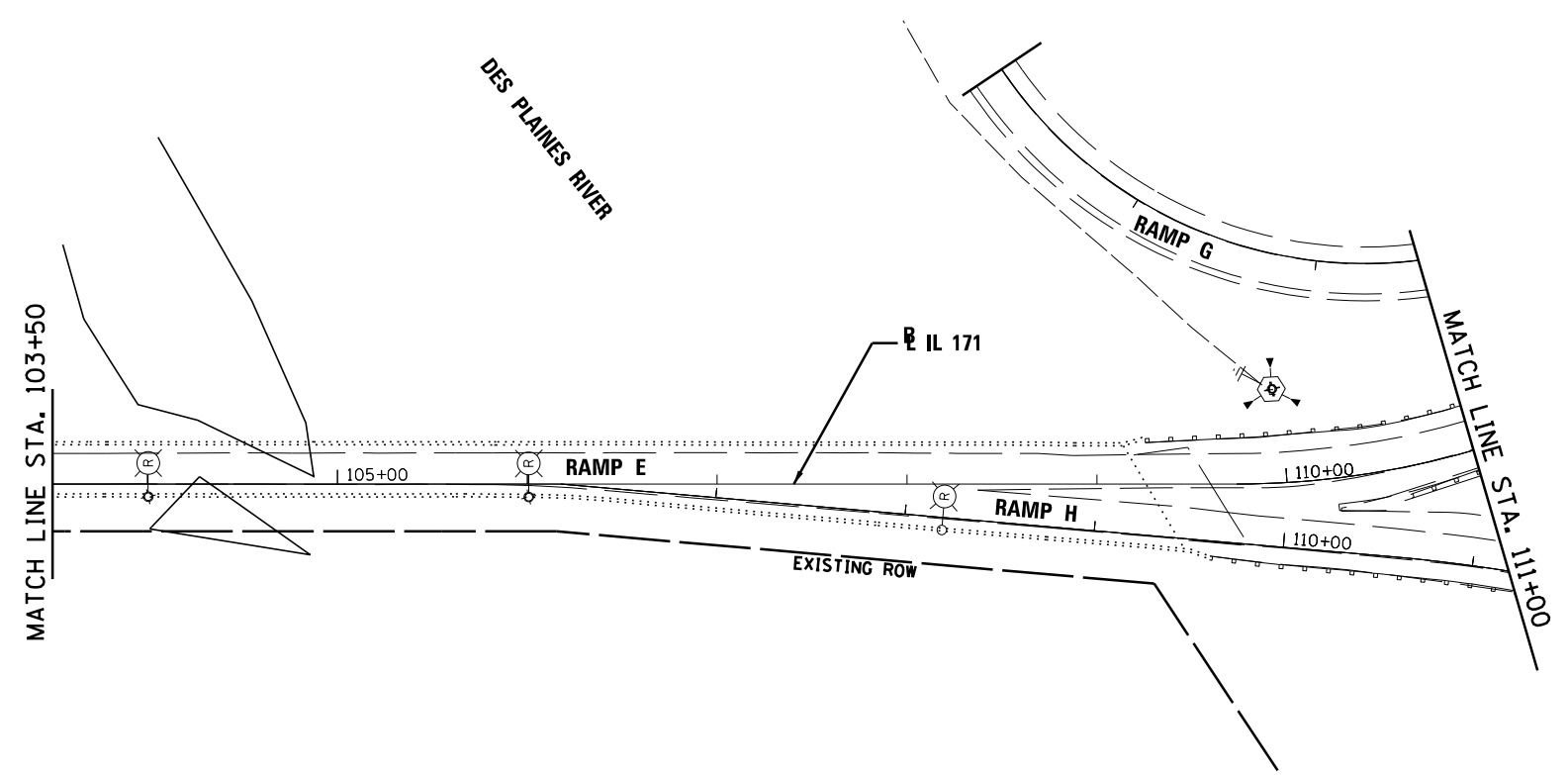
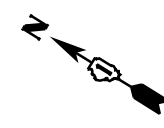

|  |                  |           |
|--|------------------|-----------|
| FILE NAME =                                | DESIGNED - GRR   | REVISED - |
| ...\\D160J16-sht-ramp E1-exlight-SB-15.dgn | DRAWN - JLW      | REVISED - |
| USER NAME = jworthington                   | CHECKED - GHT    | REVISED - |
| PLOT DATE = 6/23/2014                      | DATE - 6/23/2014 | REVISED - |



**STATE OF ILLINOIS  
DEPARTMENT OF TRANSPORTATION**

**EXISTING LIGHTING REMOVAL &  
TEMPORARY LIGHTING PLAN**

SCALE: SHEET 12 OF 49 SHEETS STA. 209+59.86 TO STA. 211+00.00

| F.A.P. RTE.        | SECTION     | COUNTY | TOTAL SHEETS              | SHEET NO. |
|--------------------|-------------|--------|---------------------------|-----------|
| 372/373            | 2013-038B-R | COOK   | 821                       | 211       |
| CONTRACT NO. 60J16 |             |        | ILLINOIS FED. AID PROJECT |           |

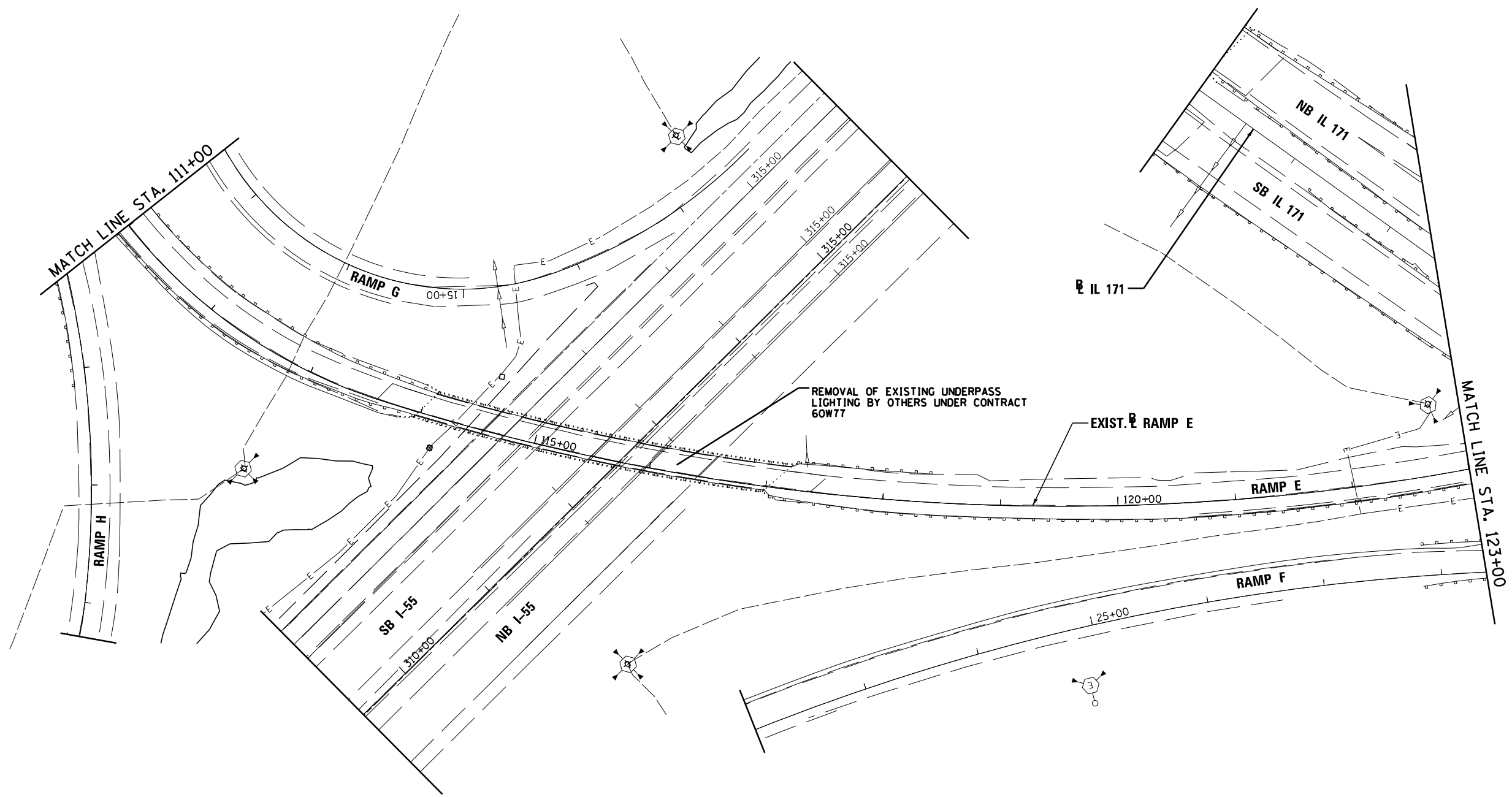

|  |                  |           |
|--|------------------|-----------|
| FILE NAME =                                | DESIGNED - GRR   | REVISED - |
| ...\\D160J16-sht-ramp E2-exlight-SB-16.dgn | DRAWN - JLW      | REVISED - |
| USER NAME = jworthington                   | CHECKED - GHT    | REVISED - |
| PLOT DATE = 6/23/2014                      | DATE - 6/23/2014 | REVISED - |



**STATE OF ILLINOIS  
DEPARTMENT OF TRANSPORTATION**

**EXISTING LIGHTING REMOVAL &  
TEMPORARY LIGHTING PLAN**

SCALE: SHEET 13 OF 49 SHEETS STA. 211+00.00 TO STA. 223+00.00

| F.A.P. RTE.        | SECTION     | COUNTY | TOTAL SHEETS              | SHEET NO. |
|--------------------|-------------|--------|---------------------------|-----------|
| 372/373            | 2013-038B-R | COOK   | 821                       | 212       |
| CONTRACT NO. 60J16 |             |        | ILLINOIS FED. AID PROJECT |           |



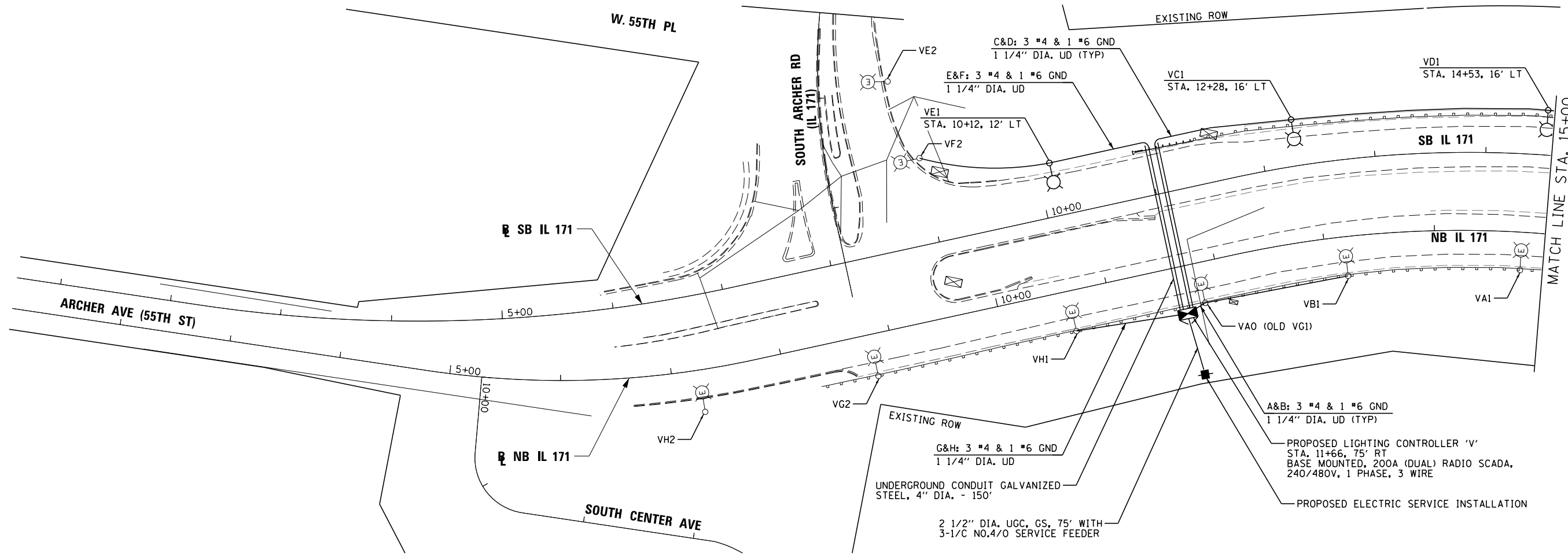

|  |                  |           |
|--|------------------|-----------|
| FILE NAME =                              | DESIGNED - GRR   | REVISED - |
| ...\\D160J16-sht-IL171-prlight-SB-01.dgn | DRAWN - JLW      | REVISED - |
| USER NAME = tblank                       | CHECKED - GHT    | REVISED - |
| PLOT DATE = 8/7/2014                     | DATE - 6/23/2014 | REVISED - |



**STATE OF ILLINOIS  
DEPARTMENT OF TRANSPORTATION**

**PROPOSED LIGHTING PLAN  
IL 171**

SCALE: SHEET 14 OF 49 SHEETS STA. 10+36.43 TO STA. 15+00.00

| F.A.P. RTE.        | SECTION     | COUNTY | TOTAL SHEETS              | SHEET NO. |
|--------------------|-------------|--------|---------------------------|-----------|
| 372/373            | 2013-038B-R | COOK   | 821                       | 213       |
| CONTRACT NO. 60J16 |             |        | ILLINOIS FED. AID PROJECT |           |

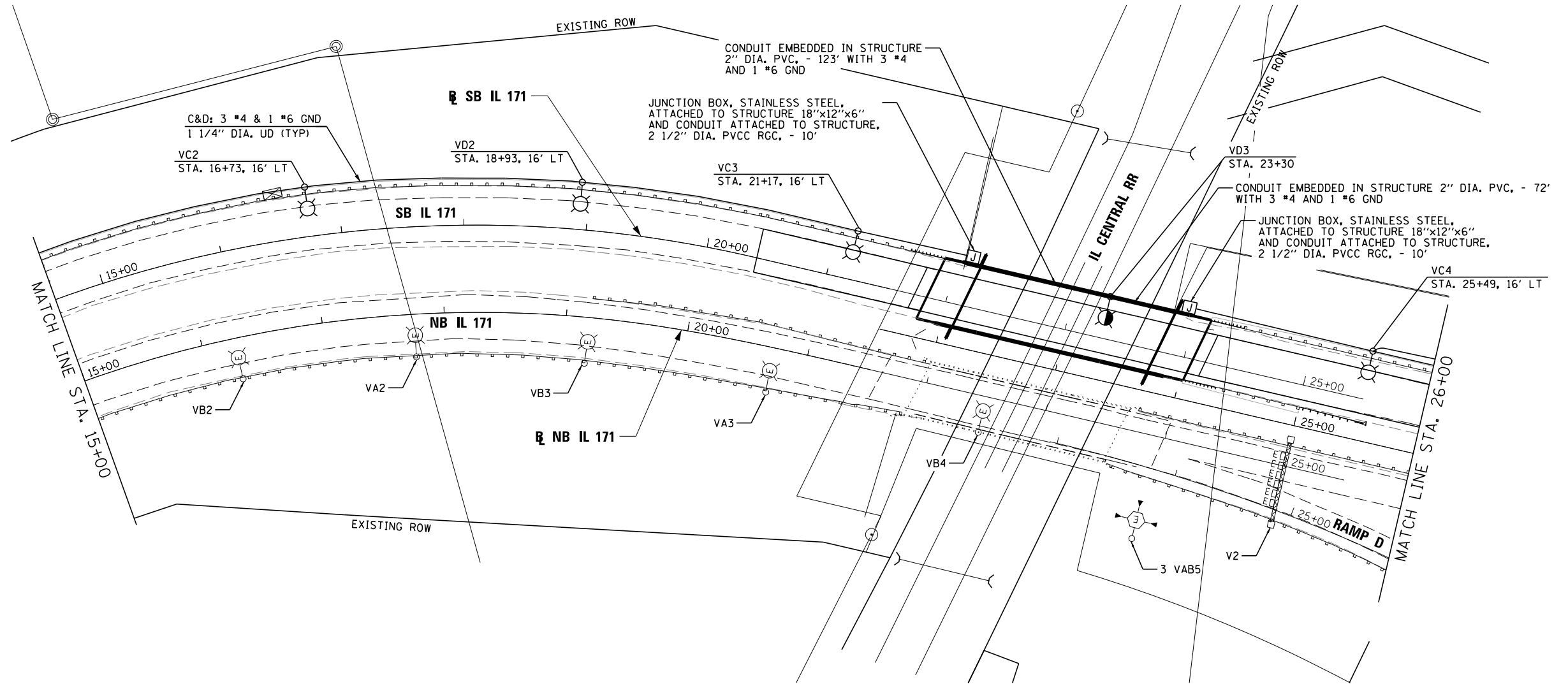

|  |                  |           |
|--|------------------|-----------|
| FILE NAME =                              | DESIGNED - GRR   | REVISED - |
| ...\\D160J16-sht-IL171-prlight-SB-02.dgn | DRAWN - JLW      | REVISED - |
| USER NAME = tblank                       | CHECKED - GHT    | REVISED - |
| PLOT DATE = 8/7/2014                     | DATE - 6/23/2014 | REVISED - |



STATE OF ILLINOIS  
DEPARTMENT OF TRANSPORTATION

PROPOSED LIGHTING PLAN  
IL 171

SCALE: SHEET 15 OF 49 SHEETS STA. 15+00.00 TO STA. 26+00.00

| F.A.P. RTE.        | SECTION     | COUNTY | TOTAL SHEETS              | SHEET NO. |
|--------------------|-------------|--------|---------------------------|-----------|
| 372/373            | 2013-038B-R | COOK   | 821                       | 214       |
| CONTRACT NO. 60J16 |             |        | ILLINOIS FED. AID PROJECT |           |

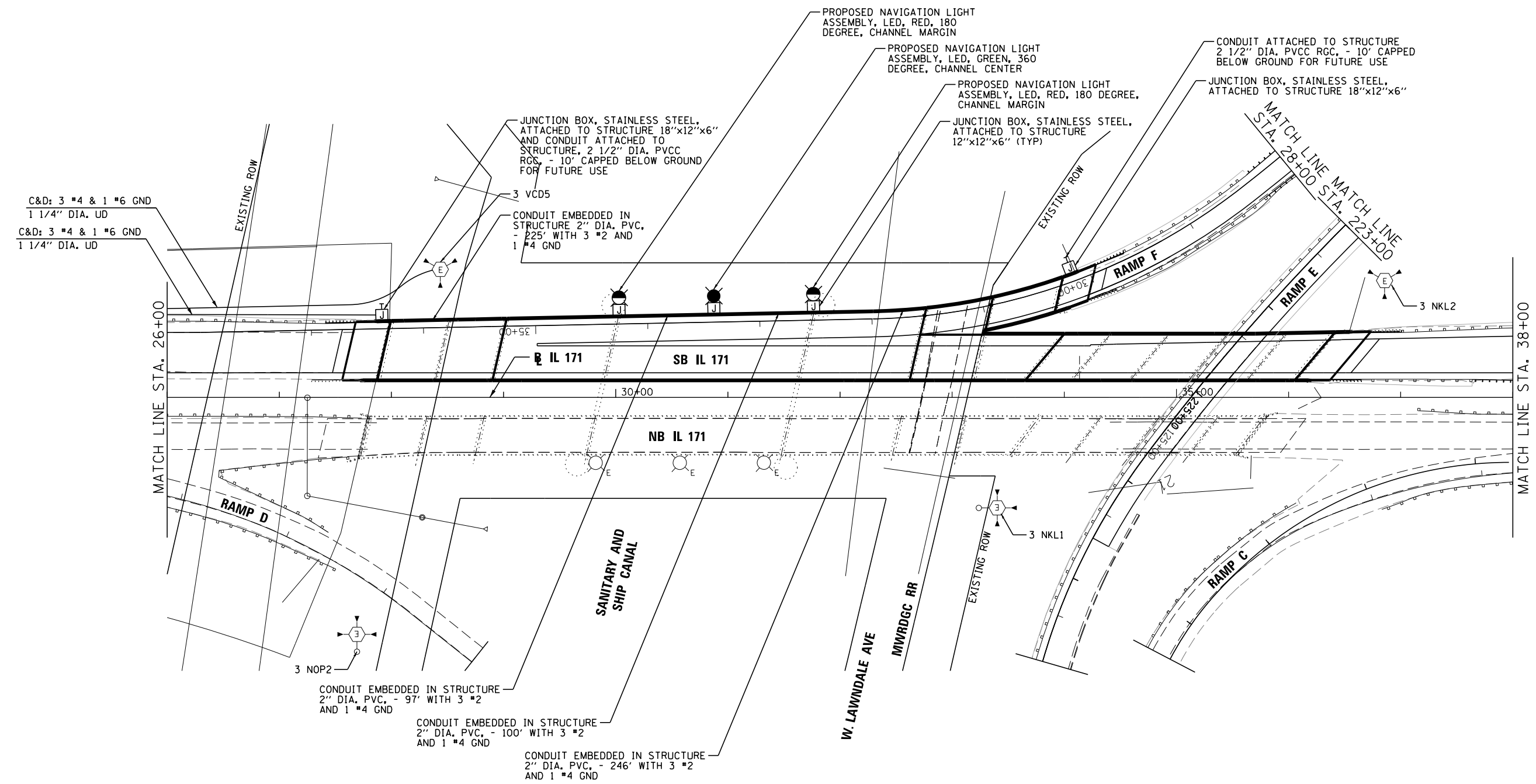

- NOTES:**
- SEE STRUCTURAL PLANS FOR LOCATIONS OF NAVIGATION LIGHT MOUNTING BRACKETS.
  - CONDUCTORS WITHIN RAMP F PARAPET UPSIZED FOR ULTIMATE CONDITION.

|  |                  |           |   |   |  |                       |                                |         |        |              |           |
|--|------------------|-----------|---|---|--|-----------------------|--------------------------------|---------|--------|--------------|-----------|
| FILE NAME =                              | DESIGNED - GRR   | REVISED - |  | <b>STATE OF ILLINOIS<br/>DEPARTMENT OF TRANSPORTATION</b> | <b>PROPOSED LIGHTING PLAN<br/>IL 171</b> |                       | F.A.P. RTE.                    | SECTION | COUNTY | TOTAL SHEETS | SHEET NO. |
| ...\\D160J16-sht-IL171-prlight-SB-03.dgn | DRAWN - JLW      | REVISED - |   |   | 372/373                                  | 2013-038B-R           | COOK                           | 821     | 215    |              |           |
| USER NAME = tblank                       | CHECKED - GHT    | REVISED - |   |   | CONTRACT NO. 60J16                       |                       |                                |         |        |              |           |
| PLOT DATE = 8/7/2014                     | DATE - 6/23/2014 | REVISED - |   |   | ILLINOIS FED. AID PROJECT                |                       |                                |         |        |              |           |
|  |                  |           |   |   | SCALE:                                   | SHEET 16 OF 49 SHEETS | STA. 26+00.00 TO STA. 38+00.00 |         |        |              |           |

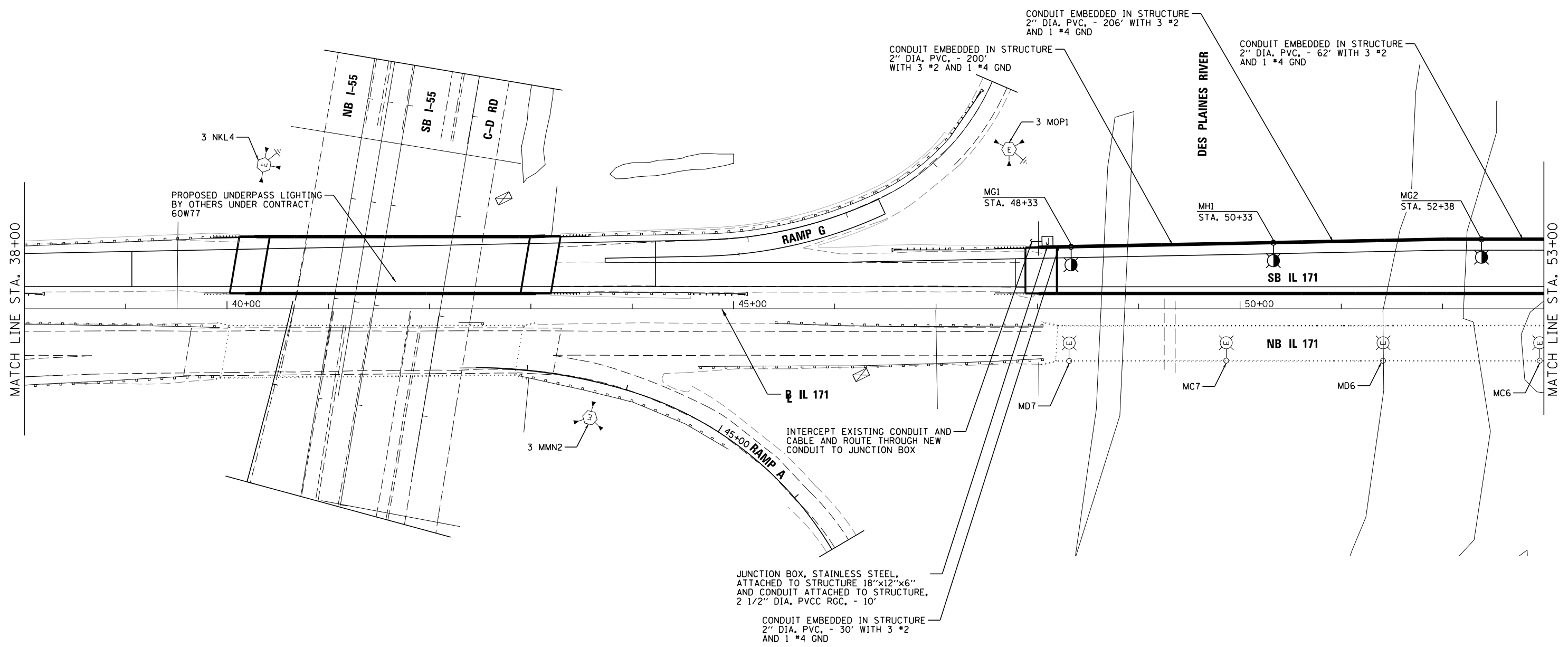

|  |                  |           |
|--|------------------|-----------|
| FILE NAME =                              | DESIGNED - GRR   | REVISED - |
| ...\\D160J16-sht-IL171-prlight-SB-04.dgn | DRAWN - JLW      | REVISED - |
| USER NAME = tblank                       | CHECKED - GHT    | REVISED - |
| PLOT DATE = 8/7/2014                     | DATE - 6/23/2014 | REVISED - |



**STATE OF ILLINOIS  
DEPARTMENT OF TRANSPORTATION**

**PROPOSED LIGHTING PLAN  
IL 171**

SCALE: SHEET 17 OF 49 SHEETS STA. 38+00.00 TO STA. 53+00.00

| F.A.P. RTE.        | SECTION     | COUNTY | TOTAL SHEETS              | SHEET NO. |
|--------------------|-------------|--------|---------------------------|-----------|
| 372/373            | 2013-038B-R | COOK   | 821                       | 216       |
| CONTRACT NO. 60J16 |             |        | ILLINOIS FED. AID PROJECT |           |

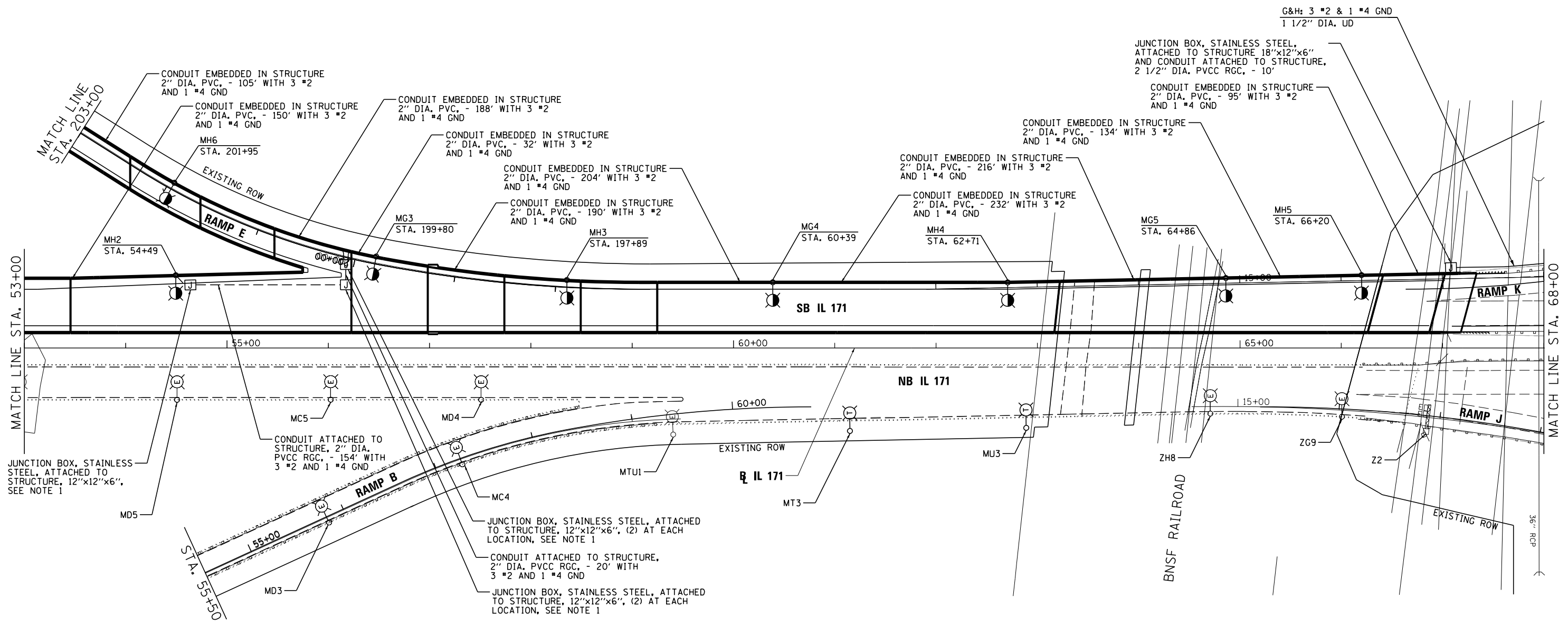

**NOTES:**

1. FOR CONDUIT TRANSITION DETAILS AND ELEVATION NEAR RAMP E GORE PIER AREA, SEE SHEET 32.
2. CONDUITS AND JUNCTION BOXES ATTACHED TO THE BRIDGE DECK SHALL BE SUPPORTED USING STAINLESS STEEL CONTINUOUS CONCRETE INSERTS (CHANNELS) 12" LONG. INSERTS SHALL BE CAST IN BRIDGE DECK.

|  |                  |           |
|--|------------------|-----------|
| FILE NAME =                              | DESIGNED - GRR   | REVISED - |
| ...\\D160J16-sht-IL171-prlight-SB-05.dgn | DRAWN - JLW      | REVISED - |
| USER NAME = tblank                       | CHECKED - GHT    | REVISED - |
| PLOT DATE = 8/7/2014                     | DATE - 6/23/2014 | REVISED - |



**STATE OF ILLINOIS  
DEPARTMENT OF TRANSPORTATION**

**PROPOSED LIGHTING PLAN  
IL 171**

SCALE: SHEET 18 OF 49 SHEETS STA. 53+00.00 TO STA. 68+00.00

|                    |             |        |                           |           |
|--------------------|-------------|--------|---------------------------|-----------|
| F.A.P. RTE.        | SECTION     | COUNTY | TOTAL SHEETS              | SHEET NO. |
| 372/373            | 2013-038B-R | COOK   | 821                       | 217       |
| CONTRACT NO. 60J16 |             |        | ILLINOIS FED. AID PROJECT |           |

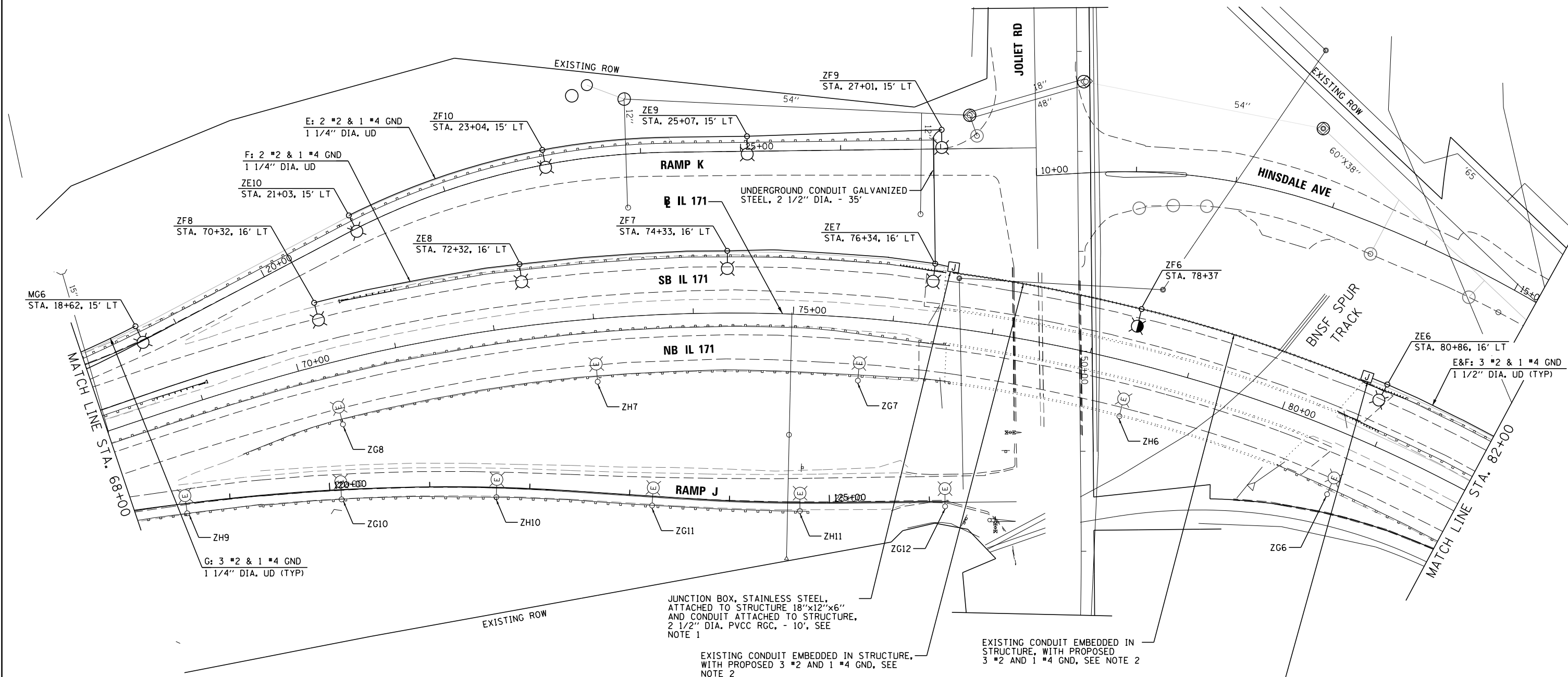
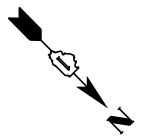

- NOTES:**
- CONTRACTOR SHALL REMOVE THE EXISTING "LB" FITTING, CONDUIT NIPPLE, AND CONDUIT RUNNING DOWN TO THE GROUND. THE COSTS FOR THIS REMOVAL WORK SHALL BE INCLUDED IN THE COST OF THE PROPOSED JUNCTION BOX. CONTRACTOR SHALL THEN INSTALL THE PROPOSED STAINLESS STEEL JUNCTION BOX WITH NEW 2" DIA. PVCC RGC NIPPLE AND 2 1/2" DIA. PVCC RGC DOWN TO THE GROUND.
  - CONTRACTOR SHALL REMOVE THE EXISTING CABLES FROM THE CONDUIT PRIOR TO INSTALLATION OF THE PROPOSED CABLES. REMOVAL OF THE EXISTING CABLES SHALL BE PAID FOR UNDER PAY ITEM "REMOVE ELECTRIC CABLE FROM CONDUIT" FOR EACH CABLE REMOVED.

|  |                  |           |
|--|------------------|-----------|
| FILE NAME =                              | DESIGNED - GRR   | REVISED - |
| ...\\D160J16-sht-IL171-prlight-SB-06.dgn | DRAWN - JLW      | REVISED - |
| USER NAME = tblank                       | CHECKED - GHT    | REVISED - |
| PLOT DATE = 8/7/2014                     | DATE - 6/23/2014 | REVISED - |



**STATE OF ILLINOIS  
DEPARTMENT OF TRANSPORTATION**

|                               |  |
|-------------------------------|--|
| <b>PROPOSED LIGHTING PLAN</b> |  |
| <b>IL 171</b>                 |  |
| SCALE:                        | SHEET 19 OF 49 SHEETS STA. 68+00.00 TO STA. 82+00.00 |

|                    |             |        |                           |           |
|--------------------|-------------|--------|---------------------------|-----------|
| F.A.P. RTE.        | SECTION     | COUNTY | TOTAL SHEETS              | SHEET NO. |
| 372/373            | 2013-038B-R | COOK   | 821                       | 218       |
| CONTRACT NO. 60J16 |             |        | ILLINOIS FED. AID PROJECT |           |

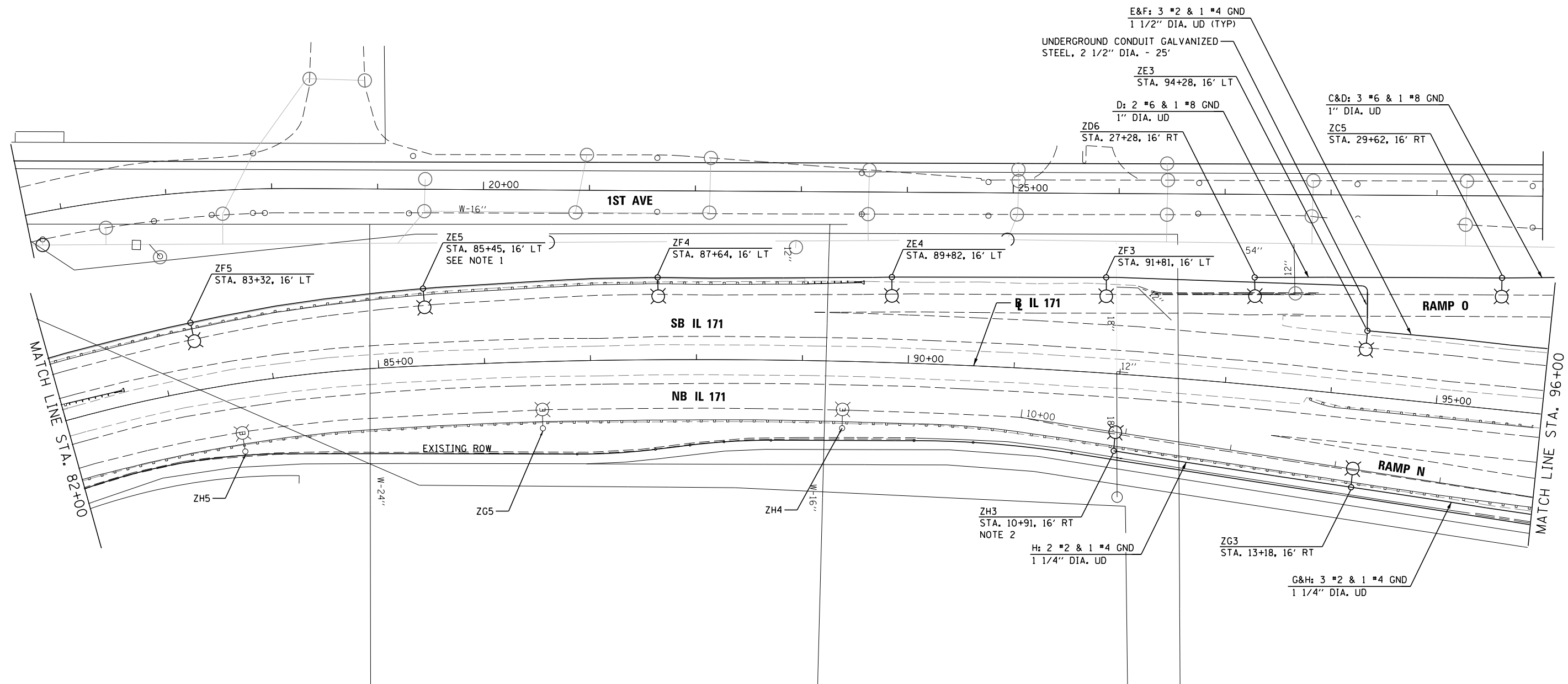
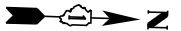

**NOTES:**

1. TO KEEP EXISTING LIGHTS SOUTH OF THIS POLE OPERATIONAL DURING STAGE 1B, CONTRACTOR SHALL INTERCEPT THE EXISTING UNIT DUCT AND TEMPORARILY CONNECT TO THIS POLE, OR AS DIRECTED BY THE ENGINEER. LIGHTING TO THE SOUTH AND NEAR JOLIET ROAD SHOULD BE REPLACED IN STAGE 1C. THE COST OF INTERCEPTING THE EXISTING UNIT DUCT SHALL BE INCLUDED IN THE COST OF THE PROPOSED UNIT DUCT.
2. CONTRACTOR SHALL INTERCEPT THE EXISTING UNIT DUCT FEEDING THE POLES SOUTH AND CONNECT TO THIS POLE. A FUTURE CONTRACT WILL REPLACE THE NB POLES SOUTH OF HERE.

|  |                  |           |
|--|------------------|-----------|
| FILE NAME =                              | DESIGNED - GRR   | REVISED - |
| ...\\D160J16-sht-IL171-prlight-SB-07.dgn | DRAWN - JLW      | REVISED - |
| USER NAME = tblank                       | CHECKED - GHT    | REVISED - |
| PLOT DATE = 8/7/2014                     | DATE - 6/23/2014 | REVISED - |



STATE OF ILLINOIS  
DEPARTMENT OF TRANSPORTATION

**PROPOSED LIGHTING PLAN  
IL 171**

SCALE: SHEET 20 OF 49 SHEETS STA. 82+00.00 TO STA. 96+00.00

| F.A.P. RTE.        | SECTION     | COUNTY | TOTAL SHEETS              | SHEET NO. |
|--------------------|-------------|--------|---------------------------|-----------|
| 372/373            | 2013-038B-R | COOK   | 821                       | 219       |
| CONTRACT NO. 60J16 |             |        | ILLINOIS FED. AID PROJECT |           |

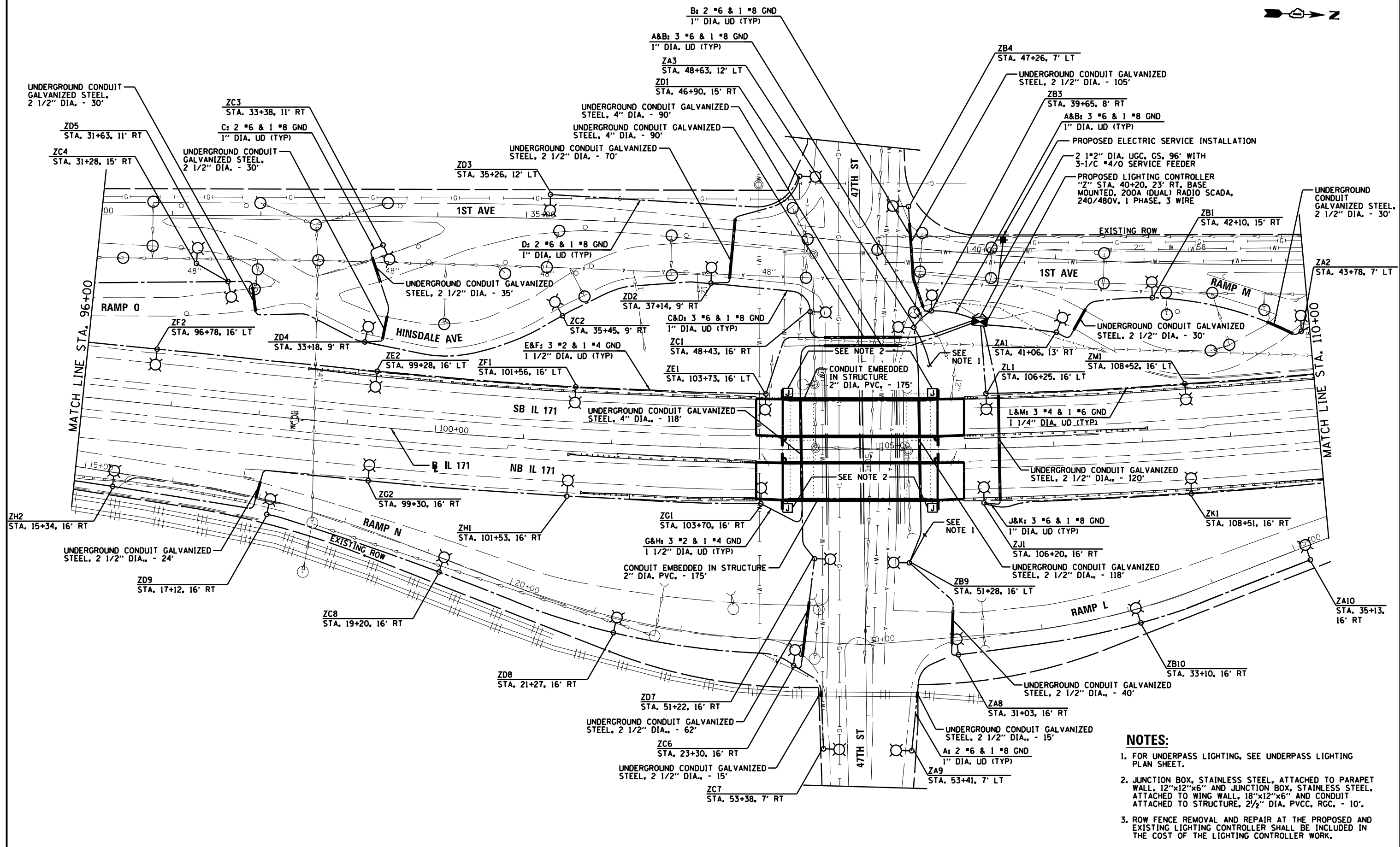

- NOTES:**
- FOR UNDERPASS LIGHTING, SEE UNDERPASS LIGHTING PLAN SHEET.
  - JUNCTION BOX, STAINLESS STEEL, ATTACHED TO PARAPET WALL, 12"x12"x6" AND JUNCTION BOX, STAINLESS STEEL, ATTACHED TO WING WALL, 18"x12"x6" AND CONDUIT ATTACHED TO STRUCTURE, 2 1/2" DIA. PVCC, RGC, - 10'.
  - ROW FENCE REMOVAL AND REPAIR AT THE PROPOSED AND EXISTING LIGHTING CONTROLLER SHALL BE INCLUDED IN THE COST OF THE LIGHTING CONTROLLER WORK.

|  |                  |           |
|--|------------------|-----------|
| FILE NAME =                              | DESIGNED - GRR   | REVISED - |
| ...\\D160J16-sht-IL171-prlight-SB-08.dgn | DRAWN - JLW      | REVISED - |
| USER NAME = jworthington                 | CHECKED - GHT    | REVISED - |
| PLOT DATE = 6/23/2014                    | DATE - 6/23/2014 | REVISED - |



STATE OF ILLINOIS  
DEPARTMENT OF TRANSPORTATION

PROPOSED LIGHTING PLAN  
IL 171

SCALE: SHEET 21 OF 49 SHEETS STA. 96+00.00 TO STA. 110+00.00

|                    |             |        |                           |           |
|--------------------|-------------|--------|---------------------------|-----------|
| F.A.P. RTE.        | SECTION     | COUNTY | TOTAL SHEETS              | SHEET NO. |
| 372/373            | 2013-038B-R | COOK   | 821                       | 220       |
| CONTRACT NO. 60J16 |             |        | ILLINOIS FED. AID PROJECT |           |



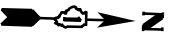

UNDERGROUND CONDUIT GALVANIZED  
STEEL, 2 1/2" DIA. - 25'

ZB2  
STA. 45+12, 14' RT

B<sub>2</sub> 2 #6 & 1 #8 GND  
1 1/4" DIA. UD

ZL2  
STA. 111+00, 16' LT

UNDERGROUND CONDUIT  
GALVANIZED STEEL,  
2 1/2" DIA. - 25'

L&M<sub>2</sub> 3 #4 & 1 #6 GND  
1 1/4" DIA. UD (TYP)

ZM2  
STA. 113+01, 12' LT

ZL3  
STA. 114+88, 12' LT

EXISTING ROW

ZM3  
STA. 116+85, 10' LT

ZL4  
STA. 118+93, 8' LT

HINSDALE AVE

SB IL 171

NB IL 171

B IL 171

EXISTING ROW

ZJ4  
STA. 118+92, 16' RT

ZK4  
STA. 120+97, 16' RT

MATCH LINE STA. 110+00

MATCH LINE STA. 121+00

RAMP M

RAMP L

ZJ3  
STA. 40+39, 16' RT

ZK3  
STA. 42+33, 16' RT

ZK2  
STA. 38+50, 10' RT

J&K<sub>2</sub> 3 #6 & 1 #8 GND  
1" DIA. UD (TYP)

ZJ2  
STA. 111+06, 16' RT

UNDERGROUND CONDUIT GALVANIZED  
STEEL, 2 1/2" DIA. - 24'

|   |                |           |   |   |  |                       |                               |             |                           |              |           |
|---|----------------|-----------|---|---|--|-----------------------|-------------------------------|-------------|---------------------------|--------------|-----------|
| FILE NAME =<br>...\\D160J16-sht-IL171-prlight-SB-09.dgn | DESIGNED - GRR | REVISED - |  | <b>STATE OF ILLINOIS</b><br><b>DEPARTMENT OF TRANSPORTATION</b> | <b>PROPOSED LIGHTING PLAN</b><br><b>IL 171</b> |                       | F.A.P. RTE.                   | SECTION     | COUNTY                    | TOTAL SHEETS | SHEET NO. |
| USER NAME = jworthington                                | DRAWN - JLW    | REVISED - |   |   |  |                       | 372/373                       | 2013-038B-R | COOK                      | 821          | 221       |
| PLOT DATE = 6/23/2014                                   | CHECKED - GHT  | REVISED - |   |   | <b>CONTRACT NO. 60J16</b>                      |                       |                               |             | ILLINOIS FED. AID PROJECT |              |           |
| DATE - 6/23/2014  | REVISOR -      | REVISED - |   |   | SCALE:   | SHEET 22 OF 49 SHEETS | STA. 110+00.00 TO STA. 121+00 |             |                           |              |           |

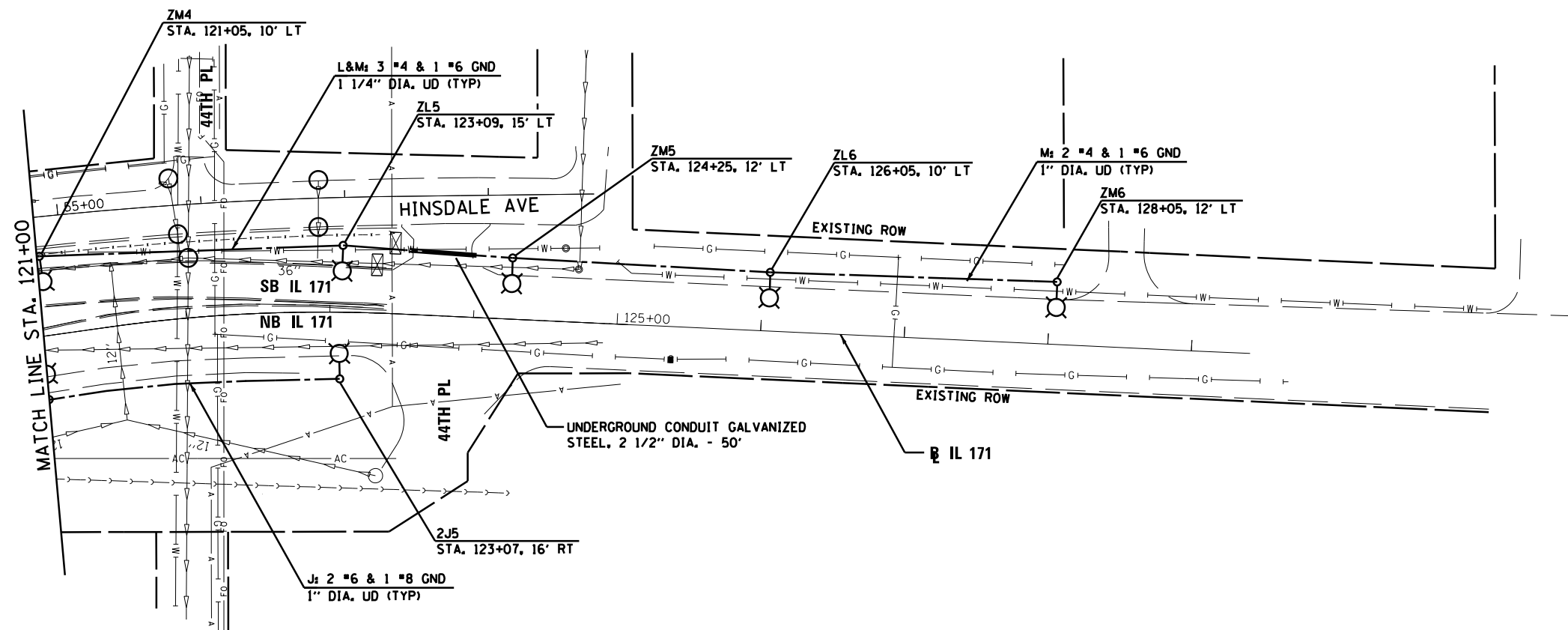

|  |                  |           |
|--|------------------|-----------|
| FILE NAME =                              | DESIGNED - GRR   | REVISED - |
| ...\\D160J16-sht-IL171-prlight-SB-10.dgn | DRAWN - JLW      | REVISED - |
| USER NAME = jworthington                 | CHECKED - GHT    | REVISED - |
| PLOT DATE = 6/23/2014                    | DATE - 6/23/2014 | REVISED - |



STATE OF ILLINOIS  
DEPARTMENT OF TRANSPORTATION

PROPOSED LIGHTING PLAN  
IL 171

SCALE: SHEET 23 OF 49 SHEETS STA. 121+00 TO STA. 128+05

| F.A.P. RTE.        | SECTION     | COUNTY | TOTAL SHEETS              | SHEET NO. |
|--------------------|-------------|--------|---------------------------|-----------|
| 372/373            | 2013-038B-R | COOK   | 821                       | 222       |
| CONTRACT NO. 60J16 |             |        | ILLINOIS FED. AID PROJECT |           |

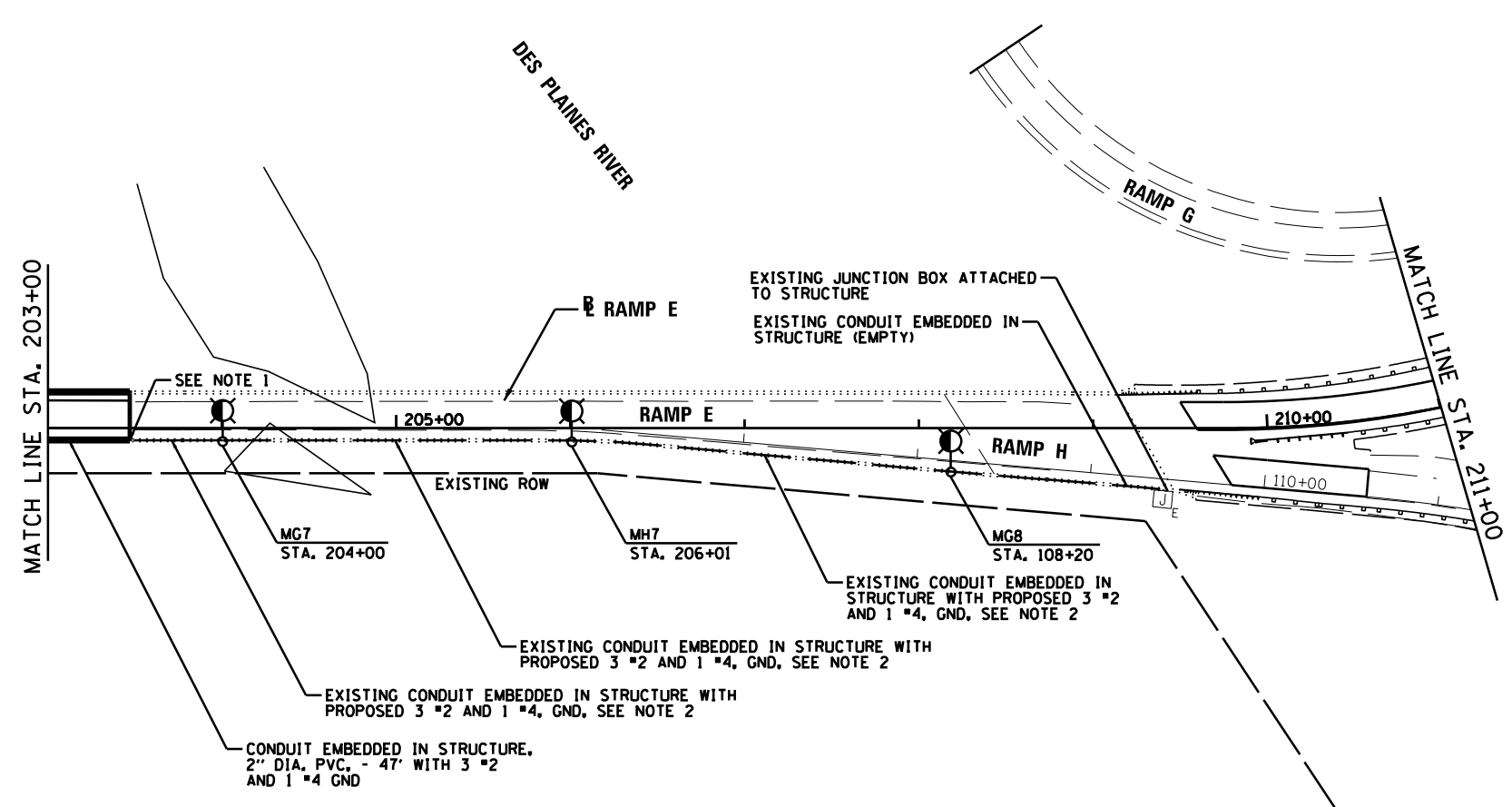
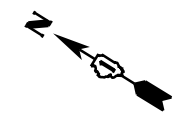

**NOTES:**

1. CONTRACTOR SHALL CONNECT THE EXISTING CONDUIT TO THE PROPOSED CONDUIT. CONTRACTOR SHALL USE CONDUIT REDUCER FITTING AS NECESSARY IF EXISTING CONDUIT SIZE IS DIFFERENT THAN PROPOSED.
2. CONTRACTOR SHALL REMOVE THE EXISTING CABLES FROM THE CONDUIT PRIOR TO INSTALLATION OF THE PROPOSED CABLES. REMOVAL OF THE EXISTING CABLES SHALL BE PAID FOR UNDER THE PAY ITEM "REMOVE ELECTRIC CABLE FROM CONDUIT" FOR EACH CABLE REMOVED.

|   |                |           |   |   |  |                       |                                  |             |                           |              |           |
|---|----------------|-----------|---|---|--|-----------------------|----------------------------------|-------------|---------------------------|--------------|-----------|
| FILE NAME =<br>...\\D160J16-sht-ramp E1-prlight-SB-15.dgn | DESIGNED - GRR | REVISED - |  | <b>STATE OF ILLINOIS</b><br><b>DEPARTMENT OF TRANSPORTATION</b> | <b>PROPOSED LIGHTING PLAN</b><br><b>RAMP E</b> |                       | F.A.P. RTE.                      | SECTION     | COUNTY                    | TOTAL SHEETS | SHEET NO. |
| USER NAME = jworthington                                  | DRAWN - JLW    | REVISED - |   |   |  |                       | 372/373                          | 2013-038B-R | COOK                      | 821          | 223       |
| PLOT DATE = 6/23/2014                                     | CHECKED - GHT  | REVISED - |   |   | CONTRACT NO. 60J16                             |                       |                                  |             | ILLINOIS FED. AID PROJECT |              |           |
| DATE - 6/23/2014  | REVISI         | DATE -    |   |   | SCALE:   | SHEET 24 OF 49 SHEETS | STA. 209+59.86 TO STA. 211+00.00 |             |                           |              |           |

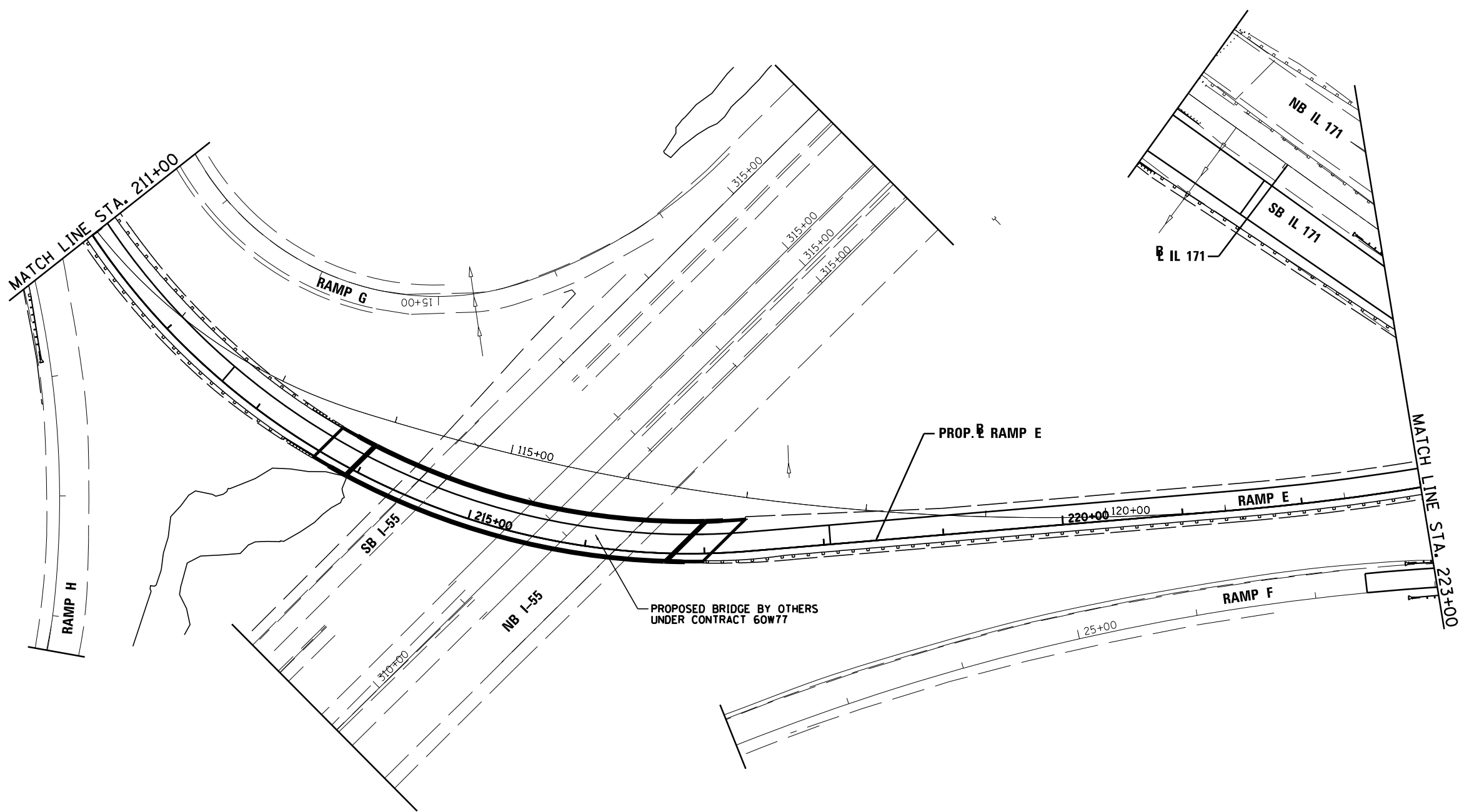

**NOTE:**  
 1. FOR INFORMATION ONLY. NO PROPOSED WORK THIS SHEET.

|   |                |           |   |   |  |  |  |   |             |        |              |           |
|---|----------------|-----------|---|---|--|--|--|---|-------------|--------|--------------|-----------|
| FILE NAME =<br>...\\D160J16-sht-ramp E2-prlight-SB-16.dgn | DESIGNED - GRR | REVISED - |  | <b>STATE OF ILLINOIS</b><br><b>DEPARTMENT OF TRANSPORTATION</b> | <b>PROPOSED LIGHTING PLAN</b><br><b>RAMP E</b>               |  |  | F.A.P. RTE.                                     | SECTION     | COUNTY | TOTAL SHEETS | SHEET NO. |
| USER NAME = jworthington                                  | DRAWN - JLW    | REVISED - |   |   |  |  |  | 372/373   | 2013-038B-R | COOK   | 821          | 224       |
| PLOT DATE = 6/23/2014                                     | CHECKED - GHT  | REVISED - |   |   | SCALE: SHEET 25 OF 49 SHEETS STA. 211+00.00 TO STA.223+00.00 |  |  | CONTRACT NO. 60J16<br>ILLINOIS FED. AID PROJECT |             |        |              |           |

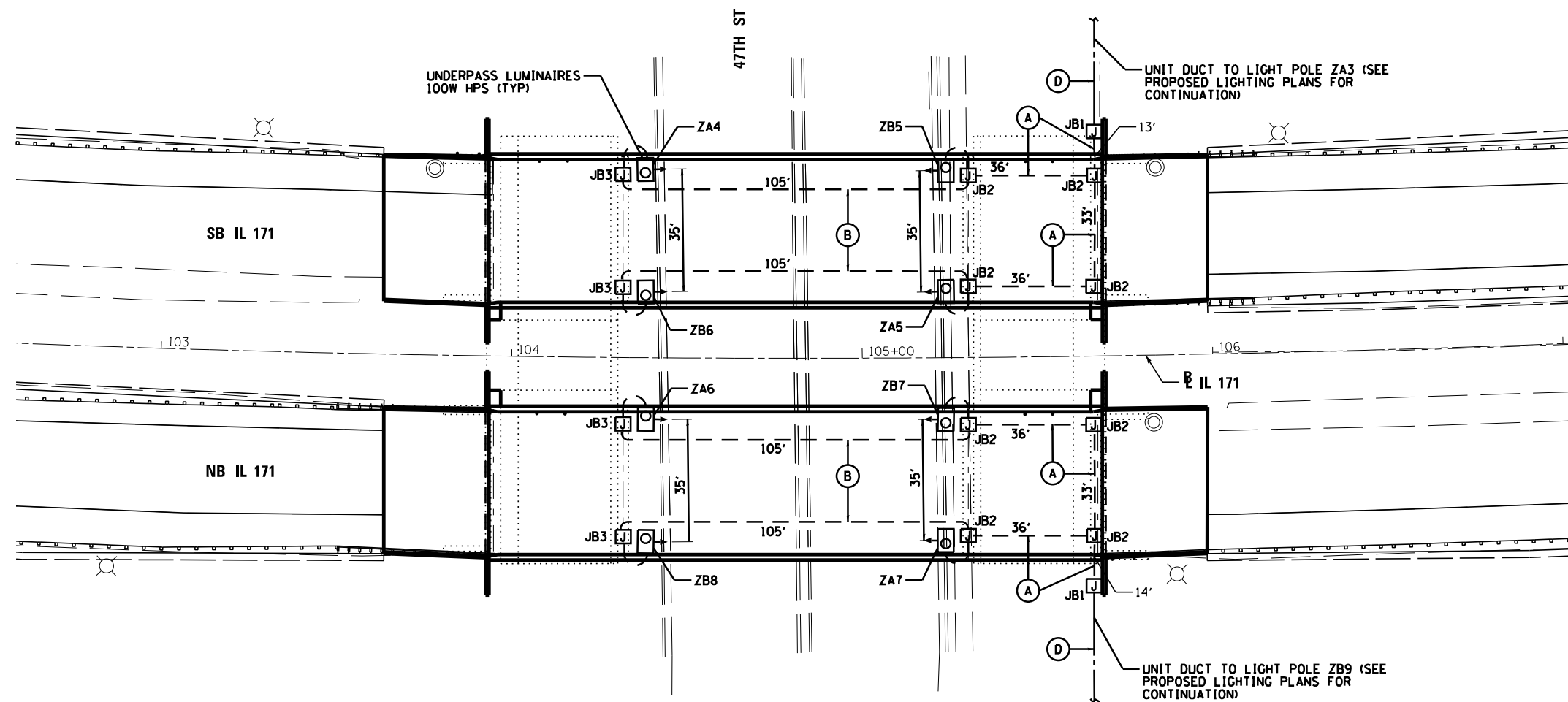

**LEGEND**

- (A) CONDUIT ATTACHED TO STRUCTURE, 1" DIA. PVCC RGC WITH 3-1/C NO. 10 AND 1/C NO. 10 GND.
- (B) CONDUIT ATTACHED TO STRUCTURE, 1" DIA. PVCC RGC WITH 2-1/C NO. 10 AND 1/C NO. 10 GND.
- (C) CONDUIT EMBEDDED IN STRUCTURE, 2" DIA. PVC WITH CABLES AS NOTED ON PLANS
- (D) CONDUIT ATTACHED TO STRUCTURE, 2 1/2" DIA. PVCC RGC, -10' WITH UNIT DUCT AS NOTED ON PLANS (FOR TRANSITION TO UNDERGROUND)
- JB1 JUNCTION BOX, STAINLESS STEEL, 18"x12"x6", ATTACHED TO WINGWALL (SEPARATE BOX FROM ONE SHOW ON LIGHTING PLAN SHEET)
- JB2 JUNCTION BOX, STAINLESS STEEL, 12"x12"x6", ATTACHED TO ABUTMENT AND TOP OF PIER CAP
- JB3 JUNCTION BOX, STAINLESS STEEL, 6"x6"x4", ATTACHED TO TOP OF PIER CAP

**NOTES:**

1. UNDERPASS LUMINAIRES SHALL BE MOUNTED TO THE FACE OF PIERS.
2. THE DISTANCES SHOWN BETWEEN THE UNDERPASS LUMINAIRE IS MEASURED FROM CENTER OF LUMINAIRES.
3. THE CABLE SPLICES AT THE JUNCTION BOX SHALL BE DONE ACCORDING TO THE SPLICING DETAIL SHOWN ON IDOT-D1 STANDARD DETAIL DRAWING NO. BE-702 PROVIDE DOUBLE POLE FUSE HOLDERS WITH 5 AMP FUSE AND SOLID NEUTRAL.
4. UNDERPASS LUMINAIRES SHALL BE INSTALLED AS SHOWN ON IDOT-D1 STANDARDS DRAWING NO. BE-902. SEE THIS DETAIL FOR FURTHER INFORMATION ON CONDUIT ROUTING AND INSTALLATION.
5. AT ALL LOCATIONS WHERE EXPANSION/CONTRACTION CAN OCCUR AND FOR CONNECTION TO LUMINAIRES THE CONTRACTOR SHALL UTILIZE LIQUID TIGHT FLEXIBLE NONMETALLIC CONDUIT.
6. SEE LIGHTING PLAN SHEET FOR CONDUIT EMBEDDED IN PARAPET WALL AND ASSOCIATED JUNCTION BOXES.

|  |                  |           |
|--|------------------|-----------|
| FILE NAME =                                      | DESIGNED - GRR   | REVISED - |
| ...ND160J16-sht-IL171-prLight-DeStr-No. 016-1000 | DRAWN - JLW      | REVISED - |
| USER NAME = jworthington                         | CHECKED - GHT    | REVISED - |
| PLOT DATE = 6/23/2014                            | DATE - 6/23/2014 | REVISED - |



STATE OF ILLINOIS  
DEPARTMENT OF TRANSPORTATION

UNDERPASS LIGHTING PLAN  
47TH STREET

SCALE: SHEET 26 OF 49 SHEETS STA. TO STA.

|                    |             |        |                           |           |
|--------------------|-------------|--------|---------------------------|-----------|
| F.A.P. RTE.        | SECTION     | COUNTY | TOTAL SHEETS              | SHEET NO. |
| 372/373            | 2013-038B-R | COOK   | 821                       | 225       |
| CONTRACT NO. 60J16 |             |        | ILLINOIS FED. AID PROJECT |           |

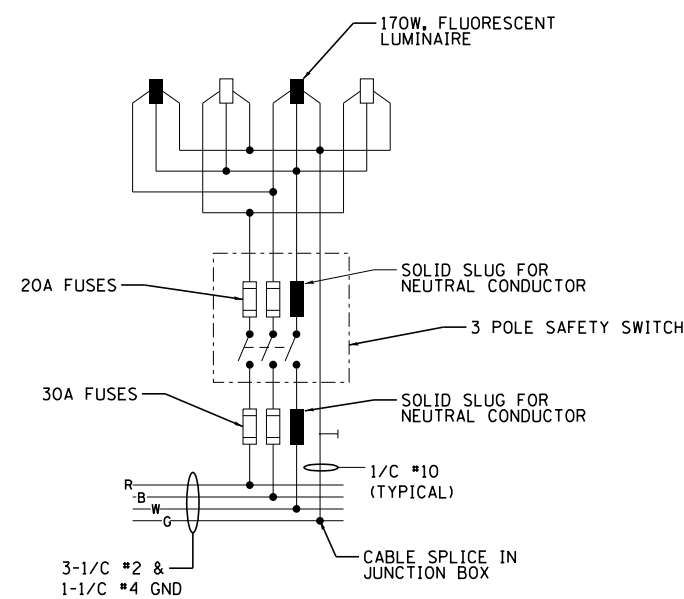

**TYPICAL LIGHTED SIGN STRUCTURE WIRING DIAGRAM**

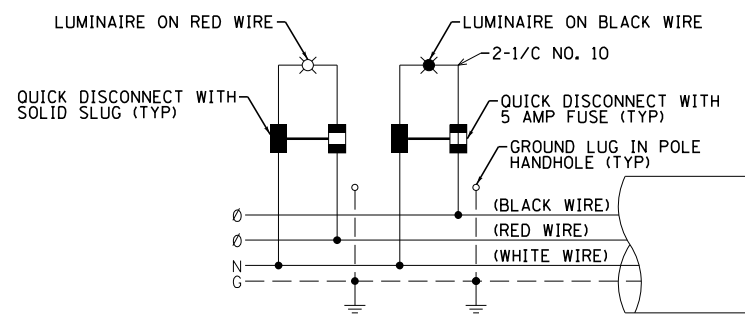

**TYPICAL LIGHT POLE WIRING DIAGRAM**

**LEGEND (THIS SHEET ONLY):**

- UNIT DUCT OR CABLE IN CONDUIT
- ⊥ ELECTRIC GROUND ROD
- ⊕ UNDERPASS LUMINAIRE, 100W HPS, 240V ON RED WIRE
- ⊖ UNDERPASS LUMINAIRE, 100W HPS, 240V ON BLACK WIRE
- ⊗ LIGHTING CONTROLLER, BASE MOUNTED, 240/480V, 200 AMP (DUAL), 1 PHASE, 3 WIRE, RADIO SCADA
- ⊠ ELECTRIC SERVICE INSTALLATION
- 240V 400W HPS MC3 HORIZONTAL MOUNT LUMINAIRE ON RED WIRE
- 240V 400W HPS MC3 HORIZONTAL MOUNT LUMINAIRE ON BLACK WIRE
- ⊙ TEMPORARY LIGHTING UNIT, WOOD POLE WITH 2-15' MAST ARMS AND 400W HPS HIGH MAST LUMINAIRES
- ⊕ HIGH MAST LIGHT TOWER, SEE TYPICAL WIRING DIAGRAM
- ⊖ 750 W HPS LUMINAIRE - RED PHASE (SOLID ON BLACK PHASE)
- 2 MAB 4 HIGH MAST TOWER DESIGNATION
- ⊠ LIGHTED SIGN STRUCTURE BLACK PHASE (RED PHASE SHOWN OPEN) SEE TYPICAL WIRING DIAGRAM BELOW.
- ⊙ NAVIGATION LIGHT

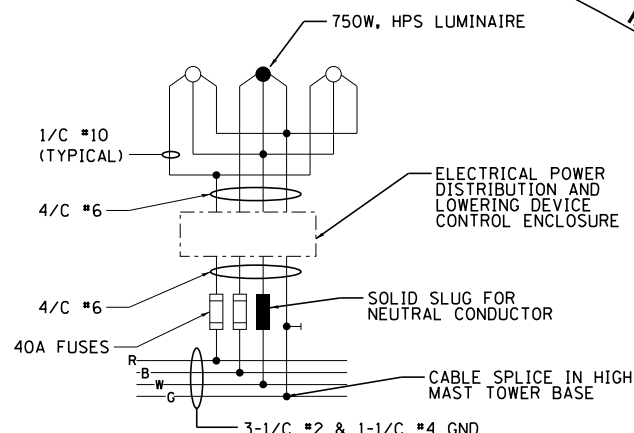
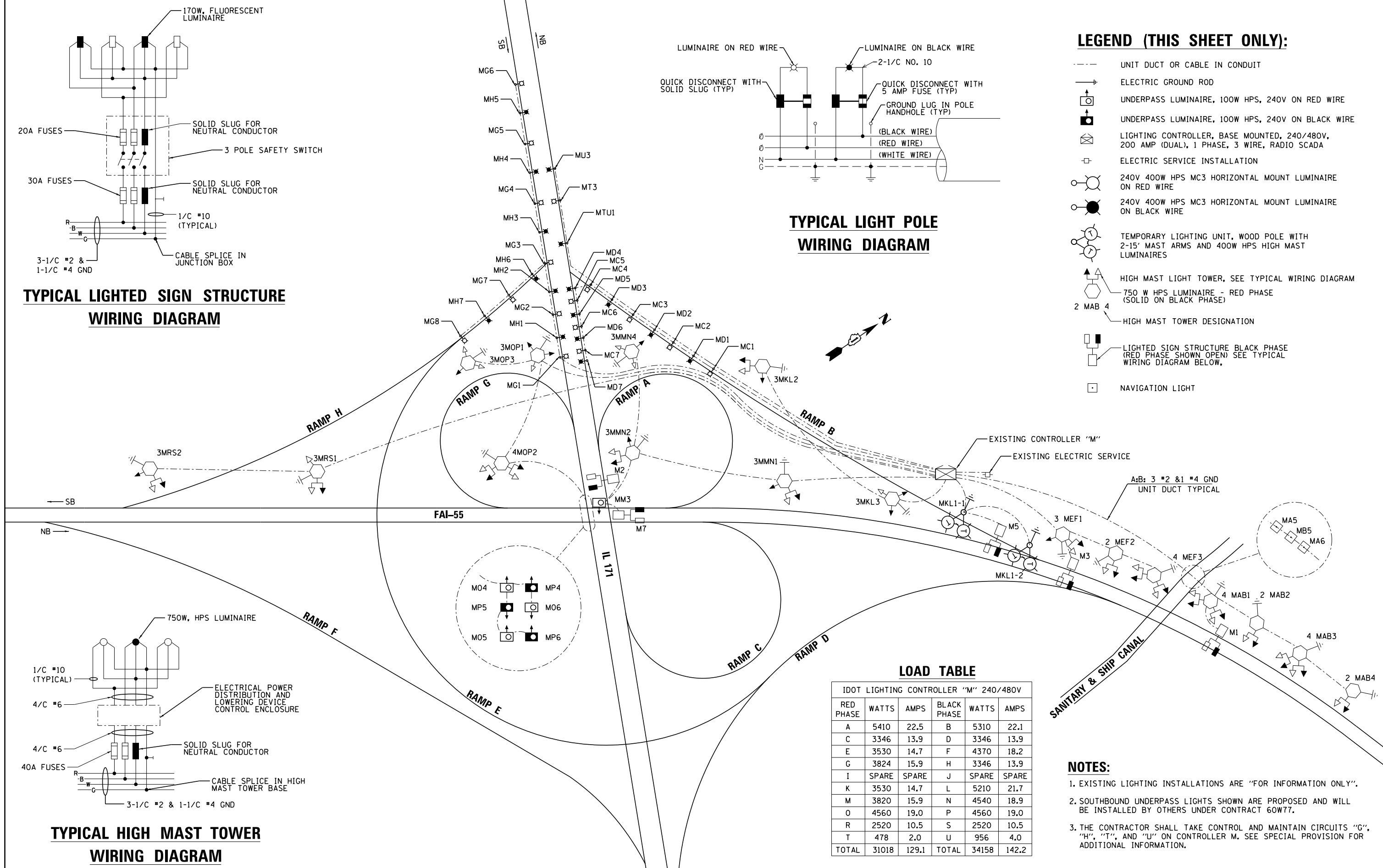

**TYPICAL HIGH MAST TOWER WIRING DIAGRAM**

**LOAD TABLE**

| IDOT LIGHTING CONTROLLER "M" 240/480V |       |       |             |       |       |
|---------------------------------------|-------|-------|-------------|-------|-------|
| RED PHASE                             | WATTS | AMPS  | BLACK PHASE | WATTS | AMPS  |
| A                                     | 5410  | 22.5  | B           | 5310  | 22.1  |
| C                                     | 3346  | 13.9  | D           | 3346  | 13.9  |
| E                                     | 3530  | 14.7  | F           | 4370  | 18.2  |
| G                                     | 3824  | 15.9  | H           | 3346  | 13.9  |
| I                                     | SPARE | SPARE | J           | SPARE | SPARE |
| K                                     | 3530  | 14.7  | L           | 5210  | 21.7  |
| M                                     | 3820  | 15.9  | N           | 4540  | 18.9  |
| O                                     | 4560  | 19.0  | P           | 4560  | 19.0  |
| R                                     | 2520  | 10.5  | S           | 2520  | 10.5  |
| T                                     | 478   | 2.0   | U           | 956   | 4.0   |
| TOTAL                                 | 31018 | 129.1 | TOTAL       | 34158 | 142.2 |

- NOTES:**
- EXISTING LIGHTING INSTALLATIONS ARE "FOR INFORMATION ONLY".
  - SOUTHBOUND UNDERPASS LIGHTS SHOWN ARE PROPOSED AND WILL BE INSTALLED BY OTHERS UNDER CONTRACT 60W77.
  - THE CONTRACTOR SHALL TAKE CONTROL AND MAINTAIN CIRCUITS "G", "H", "T", AND "U" ON CONTROLLER M. SEE SPECIAL PROVISION FOR ADDITIONAL INFORMATION.

|                                      |                  |           |
|--------------------------------------|------------------|-----------|
| FILE NAME =                          | DESIGNED - GRR   | REVISED - |
| ...\\D160J16-sht-IL171-wiring-01.dgn | DRAWN - JLW      | REVISED - |
| USER NAME = tblank                   | CHECKED - GHT    | REVISED - |
| PLOT DATE = 8/7/2014                 | DATE - 6/23/2014 | REVISED - |



STATE OF ILLINOIS  
DEPARTMENT OF TRANSPORTATION

LIGHTING CONTROLLER  
"M" WIRING DIAGRAM

SCALE: SHEET 27 OF 49 SHEETS STA. TO STA.

|                           |             |        |              |           |
|---------------------------|-------------|--------|--------------|-----------|
| F.A.P. R.T.E.             | SECTION     | COUNTY | TOTAL SHEETS | SHEET NO. |
| 372/373                   | 2013-038B-R | COOK   | 821          | 226       |
| CONTRACT NO.              |             |        | 60J16        |           |
| ILLINOIS FED. AID PROJECT |             |        |              |           |

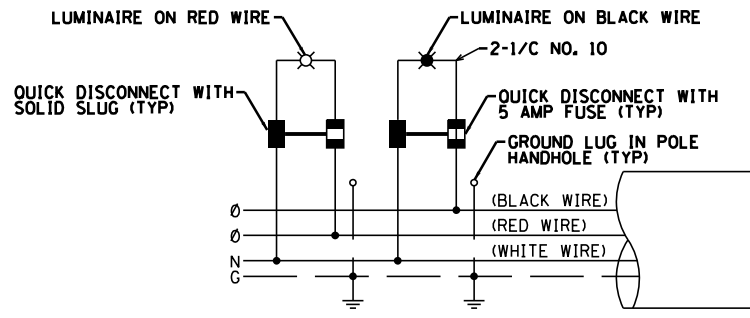

**TYPICAL LIGHT POLE WIRING DIAGRAM**

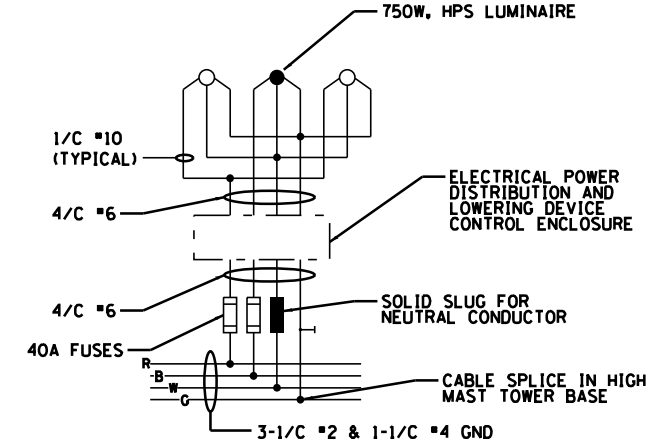

**TYPICAL HIGH MAST TOWER WIRING DIAGRAM**

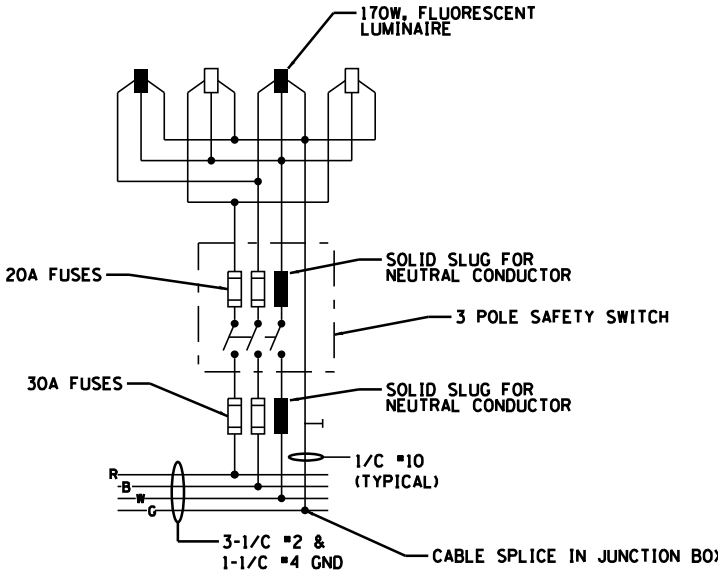
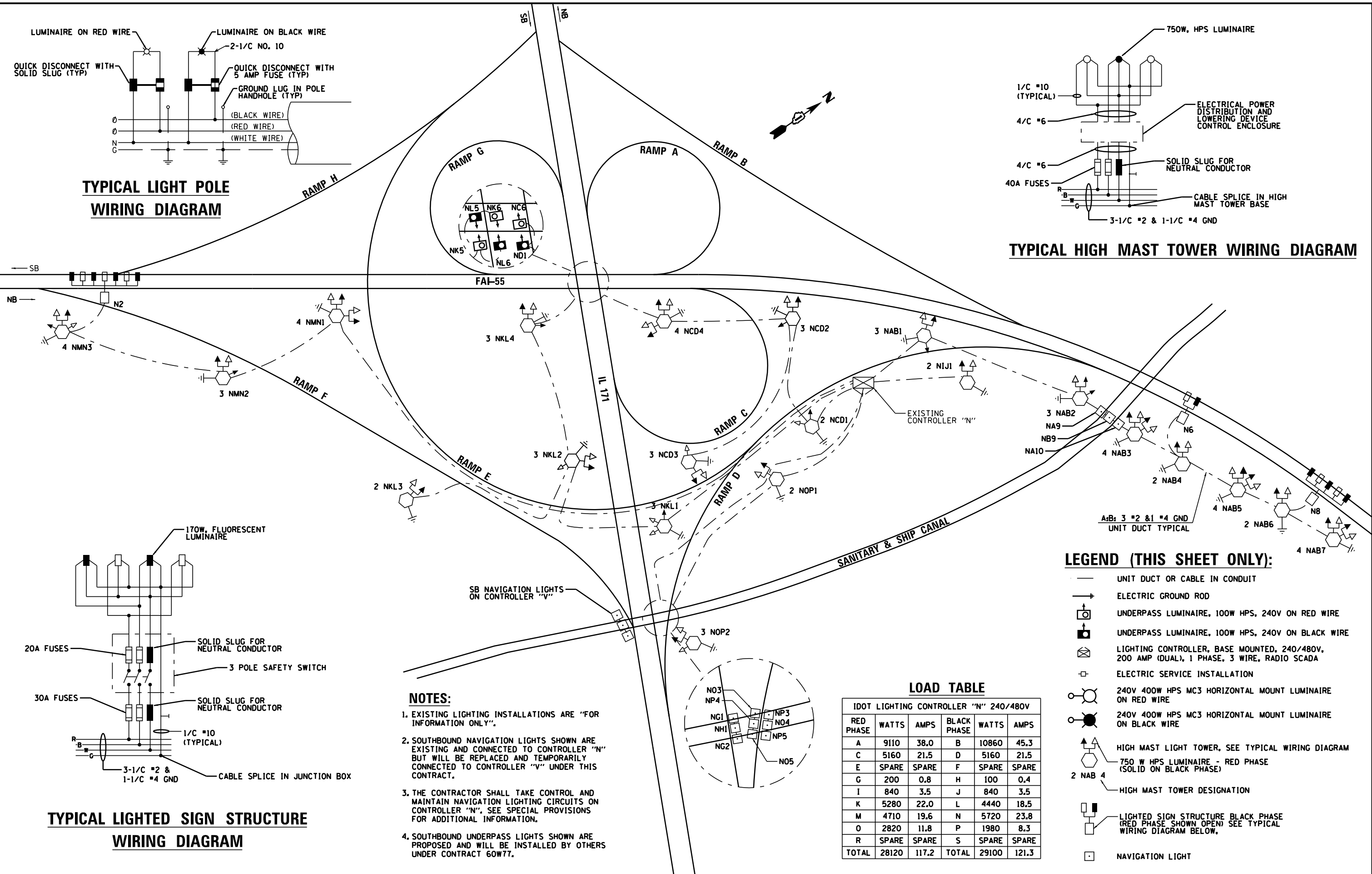

**TYPICAL LIGHTED SIGN STRUCTURE WIRING DIAGRAM**

- NOTES:**
- EXISTING LIGHTING INSTALLATIONS ARE "FOR INFORMATION ONLY".
  - SOUTHBOUND NAVIGATION LIGHTS SHOWN ARE EXISTING AND CONNECTED TO CONTROLLER "N" BUT WILL BE REPLACED AND TEMPORARILY CONNECTED TO CONTROLLER "V" UNDER THIS CONTRACT.
  - THE CONTRACTOR SHALL TAKE CONTROL AND MAINTAIN NAVIGATION LIGHTING CIRCUITS ON CONTROLLER "N". SEE SPECIAL PROVISIONS FOR ADDITIONAL INFORMATION.
  - SOUTHBOUND UNDERPASS LIGHTS SHOWN ARE PROPOSED AND WILL BE INSTALLED BY OTHERS UNDER CONTRACT 60W77.

**LOAD TABLE**

| IDOT LIGHTING CONTROLLER "N" 240/480V |       |       |             |       |       |
|---------------------------------------|-------|-------|-------------|-------|-------|
| RED PHASE                             | WATTS | AMPS  | BLACK PHASE | WATTS | AMPS  |
| A                                     | 9110  | 38.0  | B           | 10860 | 45.3  |
| C                                     | 5160  | 21.5  | D           | 5160  | 21.5  |
| E                                     | SPARE | SPARE | F           | SPARE | SPARE |
| G                                     | 200   | 0.8   | H           | 100   | 0.4   |
| I                                     | 840   | 3.5   | J           | 840   | 3.5   |
| K                                     | 5280  | 22.0  | L           | 4440  | 18.5  |
| M                                     | 4710  | 19.6  | N           | 5720  | 23.8  |
| O                                     | 2820  | 11.8  | P           | 1980  | 8.3   |
| R                                     | SPARE | SPARE | S           | SPARE | SPARE |
| TOTAL                                 | 28120 | 117.2 | TOTAL       | 29100 | 121.3 |

- LEGEND (THIS SHEET ONLY):**
- UNIT DUCT OR CABLE IN CONDUIT
  - ELECTRIC GROUND ROD
  - UNDERPASS LUMINAIRE, 100W HPS, 240V ON RED WIRE
  - UNDERPASS LUMINAIRE, 100W HPS, 240V ON BLACK WIRE
  - LIGHTING CONTROLLER, BASE MOUNTED, 240/480V, 200 AMP (DUAL), 1 PHASE, 3 WIRE, RADIO SCADA
  - ELECTRIC SERVICE INSTALLATION
  - 240V 400W HPS MC3 HORIZONTAL MOUNT LUMINAIRE ON RED WIRE
  - 240V 400W HPS MC3 HORIZONTAL MOUNT LUMINAIRE ON BLACK WIRE
  - HIGH MAST LIGHT TOWER, SEE TYPICAL WIRING DIAGRAM
  - 750 W HPS LUMINAIRE - RED PHASE (SOLID ON BLACK PHASE)
  - HIGH MAST TOWER DESIGNATION
  - LIGHTED SIGN STRUCTURE BLACK PHASE (RED PHASE SHOWN OPEN) SEE TYPICAL WIRING DIAGRAM BELOW.
  - NAVIGATION LIGHT

|                                     |                  |           |
|-------------------------------------|------------------|-----------|
| FILE NAME =                         | DESIGNED - GRR   | REVISED - |
| ...ND160J16-sht-IL171-wiring-02.dgn | DRAWN - JLW      | REVISED - |
| USER NAME = jworthington            | CHECKED - GHT    | REVISED - |
| PLOT DATE = 6/23/2014               | DATE - 6/23/2014 | REVISED - |



STATE OF ILLINOIS  
DEPARTMENT OF TRANSPORTATION

LIGHTING CONTROLLER  
"N" WIRING DIAGRAM

SCALE: SHEET 28 OF 49 SHEETS STA. TO STA.

|                    |             |        |                           |           |
|--------------------|-------------|--------|---------------------------|-----------|
| F.A.P. RTE.        | SECTION     | COUNTY | TOTAL SHEETS              | SHEET NO. |
| 372/373            | 2013-038B-R | COOK   | 821                       | 227       |
| CONTRACT NO. 60J16 |             |        | ILLINOIS FED. AID PROJECT |           |

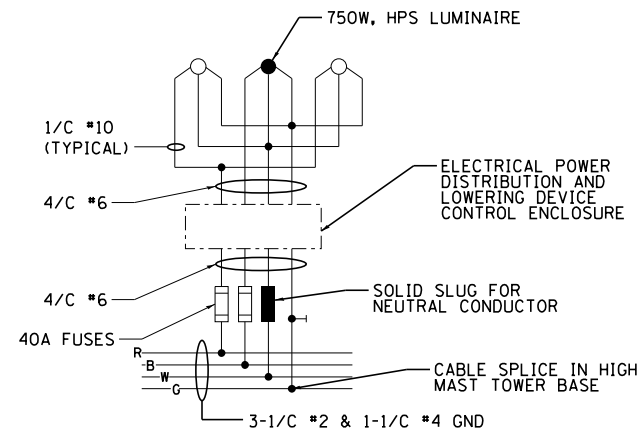

**TYPICAL HIGH MAST TOWER WIRING DIAGRAM**

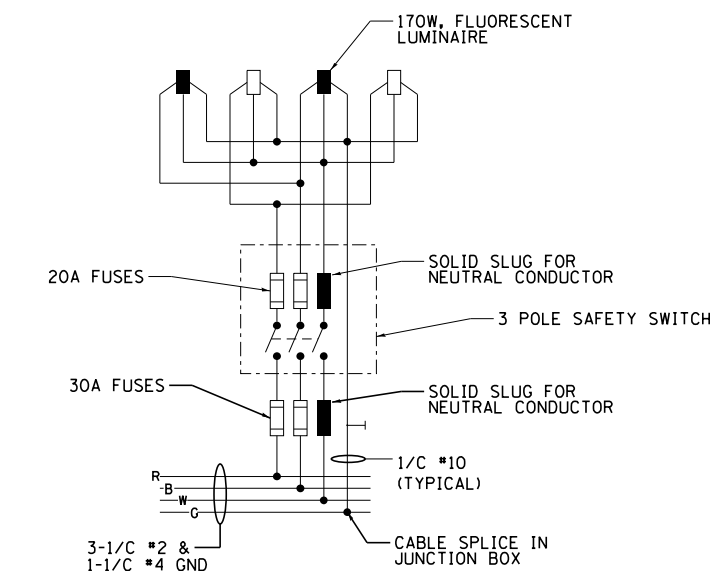

**TYPICAL LIGHTED SIGN STRUCTURE WIRING DIAGRAM**

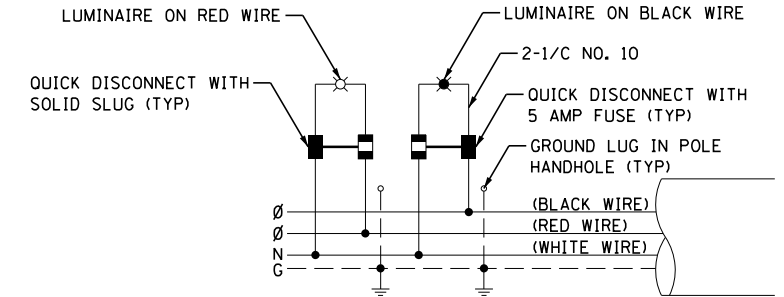

**TYPICAL LIGHT POLE WIRING DIAGRAM**

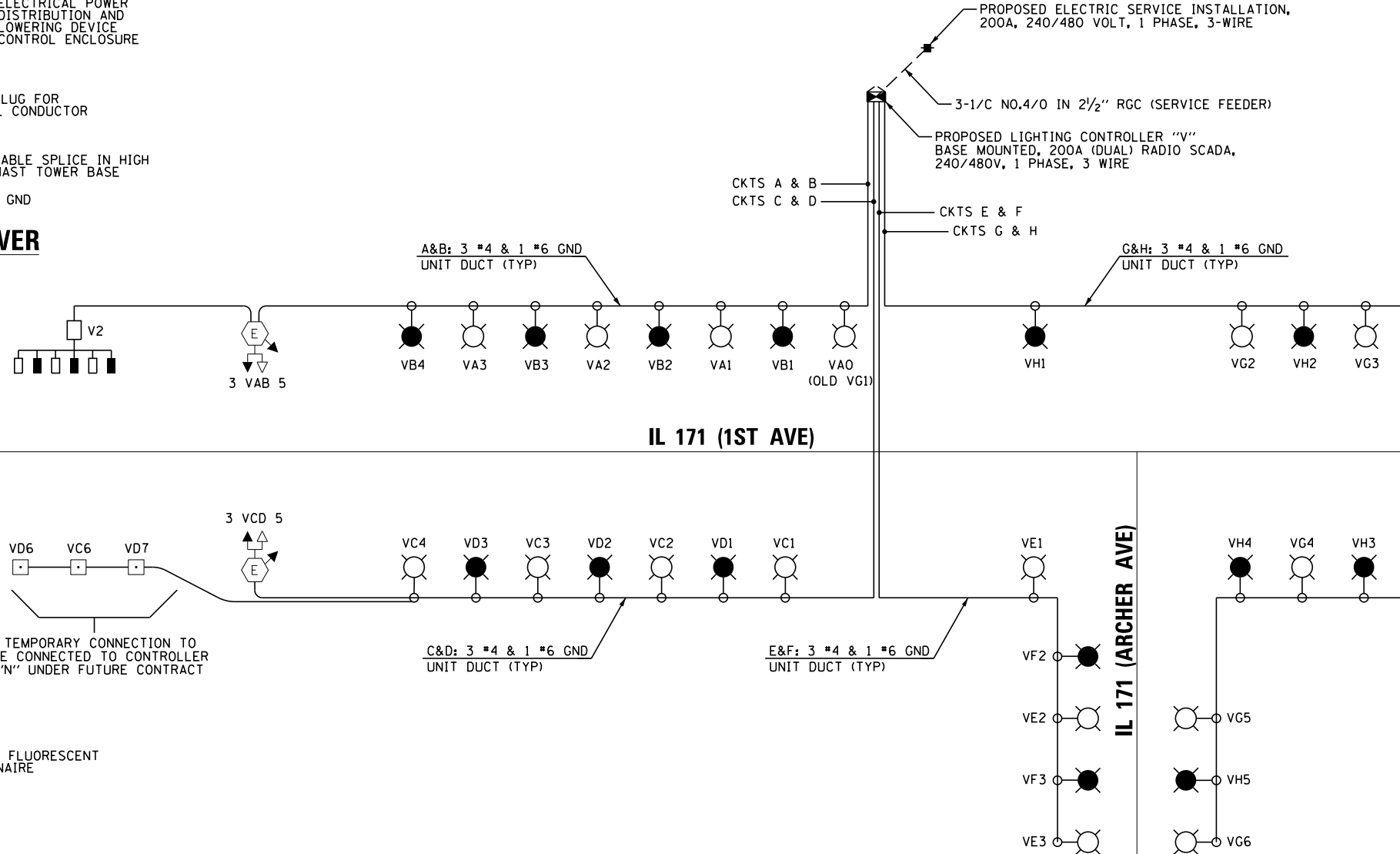

**LOAD TABLE**

IDOT LIGHTING CONTROLLER "V" 240/480V

| RED PHASE | WATTS | AMPS  | BLACK PHASE | WATTS | AMPS  |
|-----------|-------|-------|-------------|-------|-------|
| A         | 3262  | 13.6  | B           | 4102  | 17.1  |
| C         | 2760  | 11.5  | D           | 3130  | 13.0  |
| E         | 1434  | 6.0   | F           | 956   | 4.0   |
| G         | 2390  | 10.0  | H           | 2390  | 10.0  |
| I         | SPARE | SPARE | J           | SPARE | SPARE |
| TOTAL     | 9846  | 41.0  | TOTAL       | 10578 | 44.1  |

**NOTES:**

1. EXISTING LIGHTING INSTALLATIONS ARE "FOR INFORMATION ONLY".

2. NORTHBOUND LIGHTS ARE EXISTING AND WILL BE REPLACED UNDER FUTURE CONTRACT. LIGHTS AT/EAST OF ARCHER AVE ARE EXISTING TO REMAIN.

- LEGEND (THIS SHEET ONLY):**
- UNIT DUCT OR CABLE IN CONDUIT
  - ⊕ ELECTRIC GROUND ROD
  - ☑ LIGHTING CONTROLLER, BASE MOUNTED, 240/480V, 200 AMP (DUAL) RADIO SCADA, 1 PHASE, 3 WIRE
  - ELECTRIC SERVICE INSTALLATION
  - 240V 400W HPS MC3 HORIZONTAL MOUNT LUMINAIRE ON RED WIRE
  - 240V 400W HPS MC3 HORIZONTAL MOUNT LUMINAIRE ON BLACK WIRE
  - ⬆ ○ UNDERPASS LUMINAIRE, 100W HPS, 240V ON RED WIRE
  - ⬆ ● UNDERPASS LUMINAIRE, 100W HPS, 240V ON BLACK WIRE
  - ⬆ ⊕ HIGH MAST LIGHT TOWER, SEE TYPICAL WIRING DIAGRAM
  - ⬆ ⊕ 750 W HPS LUMINAIRE - RED PHASE (SOLID ON BLACK PHASE)
  - 2 NAB 4 HIGH MAST TOWER DESIGNATION
  - ☑ LIGHTED SIGN STRUCTURE BLACK PHASE (RED PHASE SHOWN OPEN) SEE TYPICAL WIRING DIAGRAM BELOW.
  - NAVIGATION LIGHT



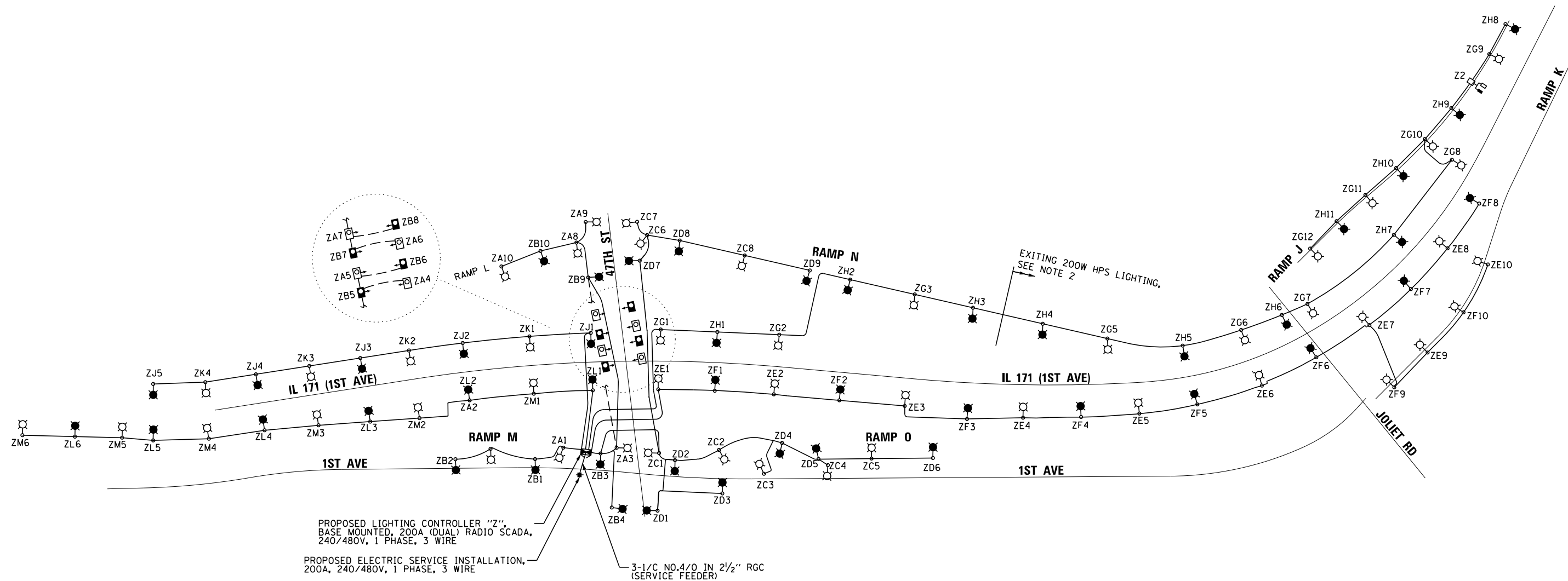

PROPOSED LIGHTING CONTROLLER "Z",  
 BASE MOUNTED, 200A (DUAL) RADIO SCADA,  
 240/480V, 1 PHASE, 3 WIRE

PROPOSED ELECTRIC SERVICE INSTALLATION,  
 200A, 240/480V, 1 PHASE, 3 WIRE

3-1/C NO.4/0 IN 2 1/2" RGC  
 (SERVICE FEEDER)

EXITING 200W HPS LIGHTING,  
 SEE NOTE 2

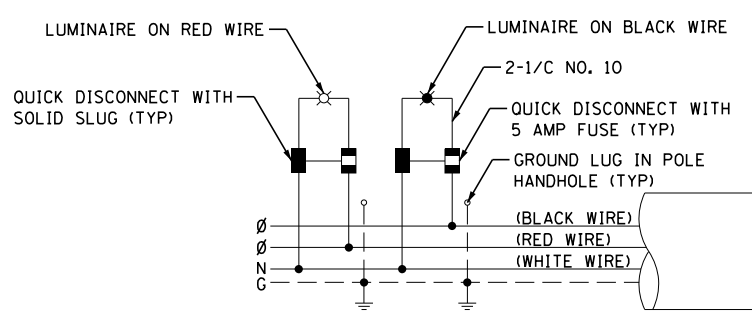

**TYPICAL LIGHT POLE  
 WIRING DIAGRAM**

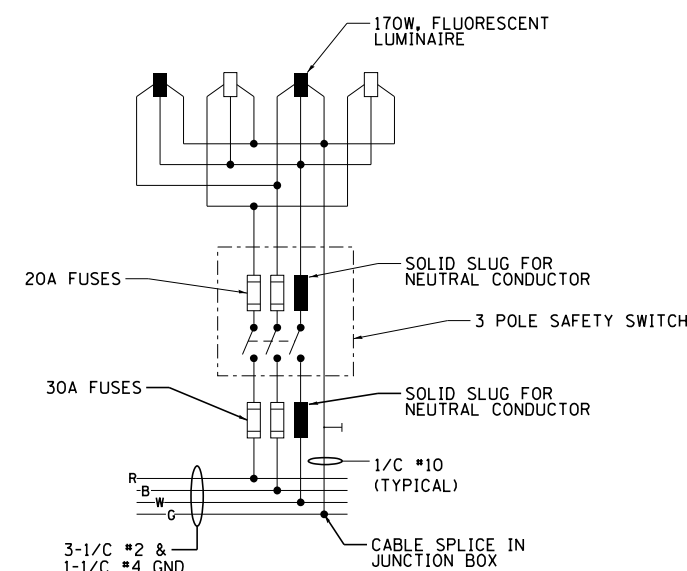

**TYPICAL LIGHTED SIGN STRUCTURE  
 WIRING DIAGRAM**

**LEGEND**

- UNIT DUCT OR CABLE IN CONDUIT
- ELECTRIC GROUND ROD
- ☑ LIGHTING CONTROLLER, BASE MOUNTED, 240/480V, 200 AMP (DUAL) RADIO SCADA, 1 PHASE, 3 WIRE
- ⊕ ELECTRIC SERVICE INSTALLATION
- 240V 400W HPS MC3 HORIZONTAL MOUNT LUMINAIRE ON RED WIRE
- 240V 400W HPS MC3 HORIZONTAL MOUNT LUMINAIRE ON BLACK WIRE
- ⊕ UNDERPASS LUMINAIRE, 100W HPS, 240V ON RED WIRE
- ⊕ UNDERPASS LUMINAIRE, 100W HPS, 240V ON BLACK WIRE
- ☐ LIGHTED SIGN STRUCTURE BLACK PHASE (RED PHASE SHOWN OPEN) SEE TYPICAL WIRING DIAGRAM BELOW

**LOAD TABLE**

| IDOT LIGHTING CONTROLLER "Z" 240/480V |       |       |             |       |       |
|---------------------------------------|-------|-------|-------------|-------|-------|
| RED PHASE                             | WATTS | AMPS  | BLACK PHASE | WATTS | AMPS  |
| A                                     | 3348  | 14.0  | B           | 3348  | 14.0  |
| C                                     | 3824  | 15.9  | D           | 4302  | 17.9  |
| E                                     | 4780  | 19.9  | F           | 4780  | 19.9  |
| G                                     | 3524  | 14.7  | H           | 3524  | 14.7  |
| I                                     | SPARE | SPARE | J           | 2390  | 10.0  |
| K                                     | 1912  | 8.0   | L           | 2868  | 12.0  |
| M                                     | 2868  | 12.0  | N           | SPARE | SPARE |
| O                                     | SPARE | SPARE | P           | SPARE | SPARE |
| TOTAL                                 | 20256 | 84.5  | TOTAL       | 21212 | 88.5  |

**NOTES:**

1. EXISTING LIGHTING INSTALLATIONS ARE "FOR INFORMATION ONLY".
2. NORTHBOUND LIGHTS SOUTH OF THE 47TH STREET INTERCHANGE ARE EXISTING AND WILL BE REPLACED UNDER FUTURE CONTRACT.

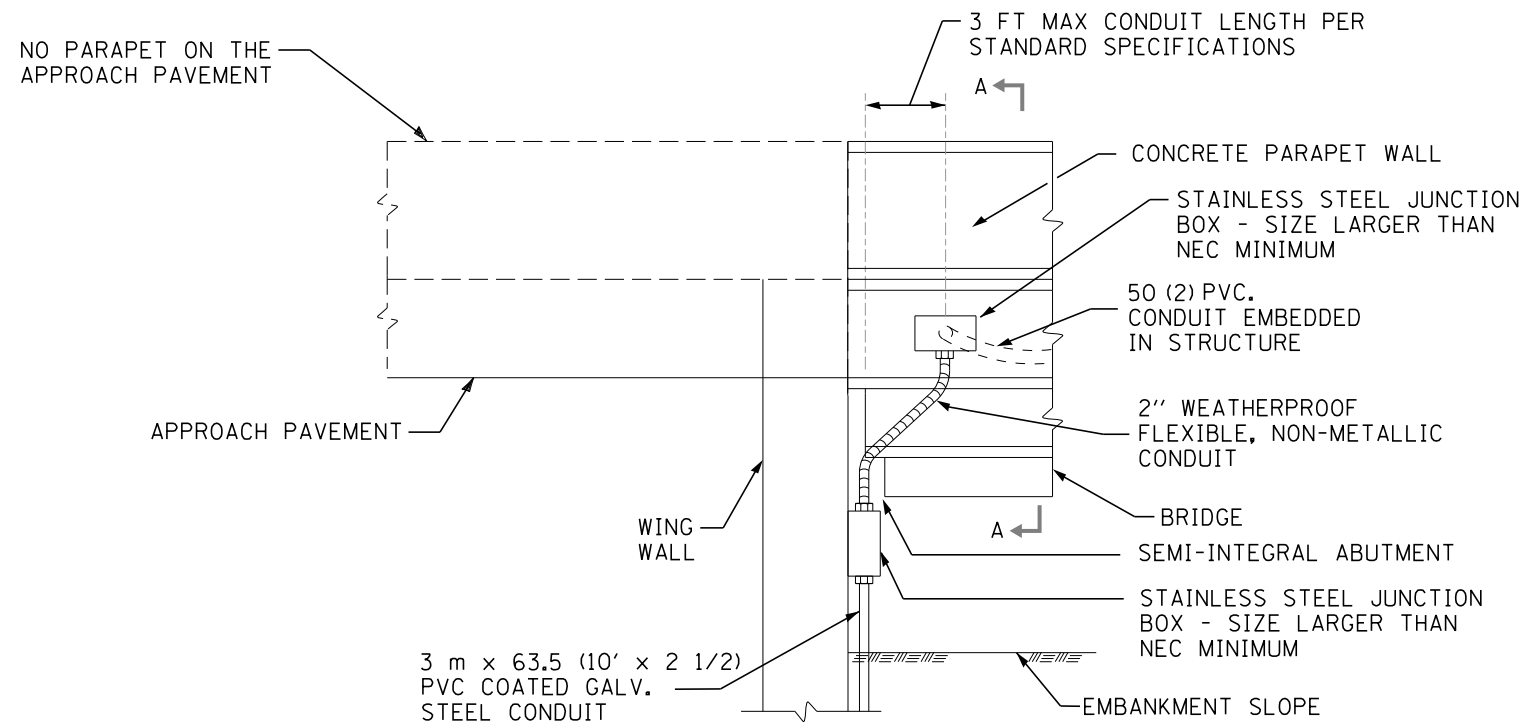

**CONDUIT DETAIL**

(SEMI-INTEGRAL ABUTMENT-SN 016-1000/1001)

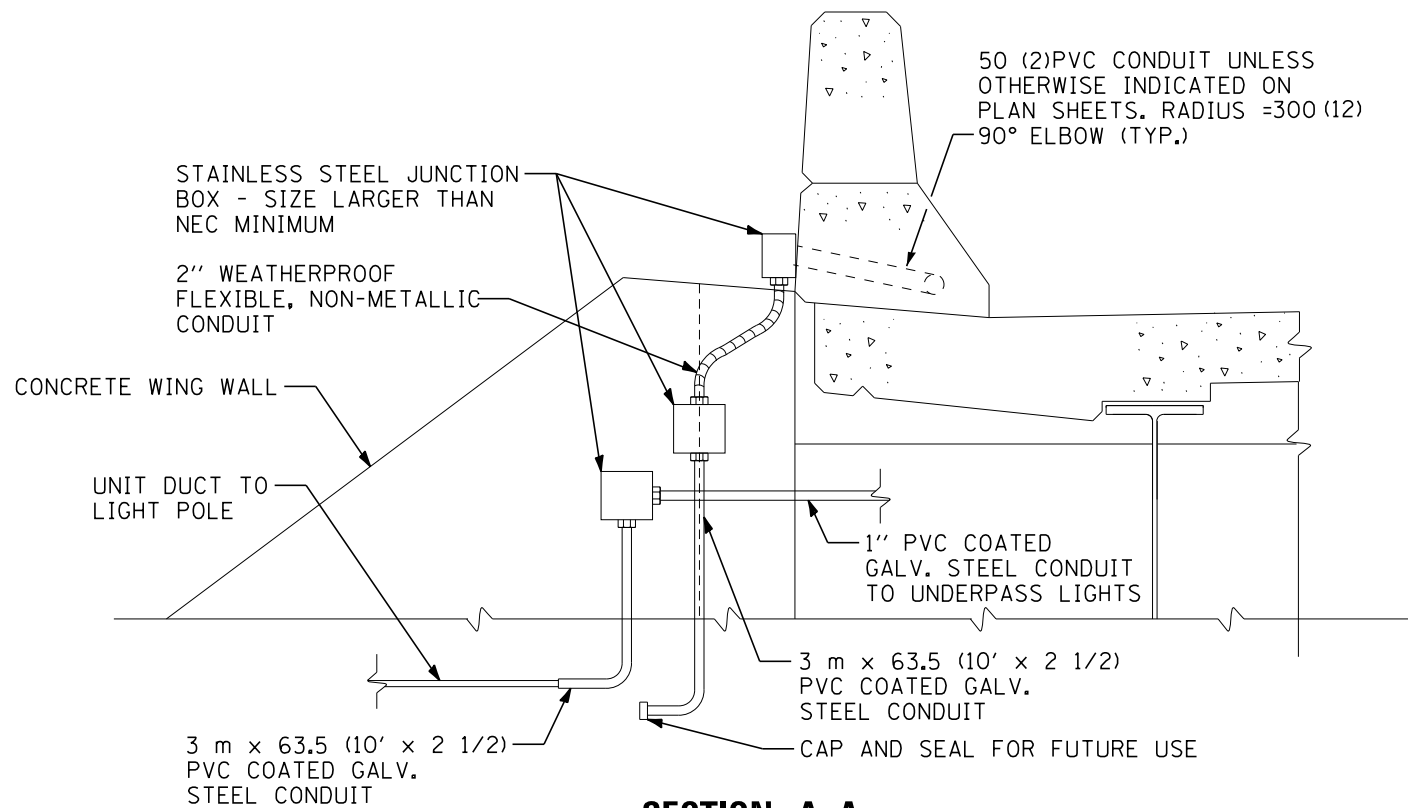

**SECTION A-A**

ALL DIMENSIONS ARE IN MILLIMETERS (INCHES) UNLESS OTHERWISE SHOWN.

|   |                  |           |
|---|------------------|-----------|
| FILE NAME =                                     | DESIGNED - GRR   | REVISED - |
| ...\\D160J16-sht-IL171-conduit-detail-SB-01.dgn | DRAWN - JLW      | REVISED - |
| USER NAME = tblank                              | CHECKED - GHT    | REVISED - |
| PLOT DATE = 8/7/2014                            | DATE - 6/23/2014 | REVISED - |



STATE OF ILLINOIS  
DEPARTMENT OF TRANSPORTATION

**CONDUIT TRANSITION DETAILS**

SCALE: SHEET 31 OF 49 SHEETS STA. TO STA.

| F.A.P. RTE.        | SECTION     | COUNTY | TOTAL SHEETS              | SHEET NO. |
|--------------------|-------------|--------|---------------------------|-----------|
| 372/373            | 2013-038B-R | COOK   | 821                       | 230       |
| CONTRACT NO. 60J16 |             |        | ILLINOIS FED. AID PROJECT |           |

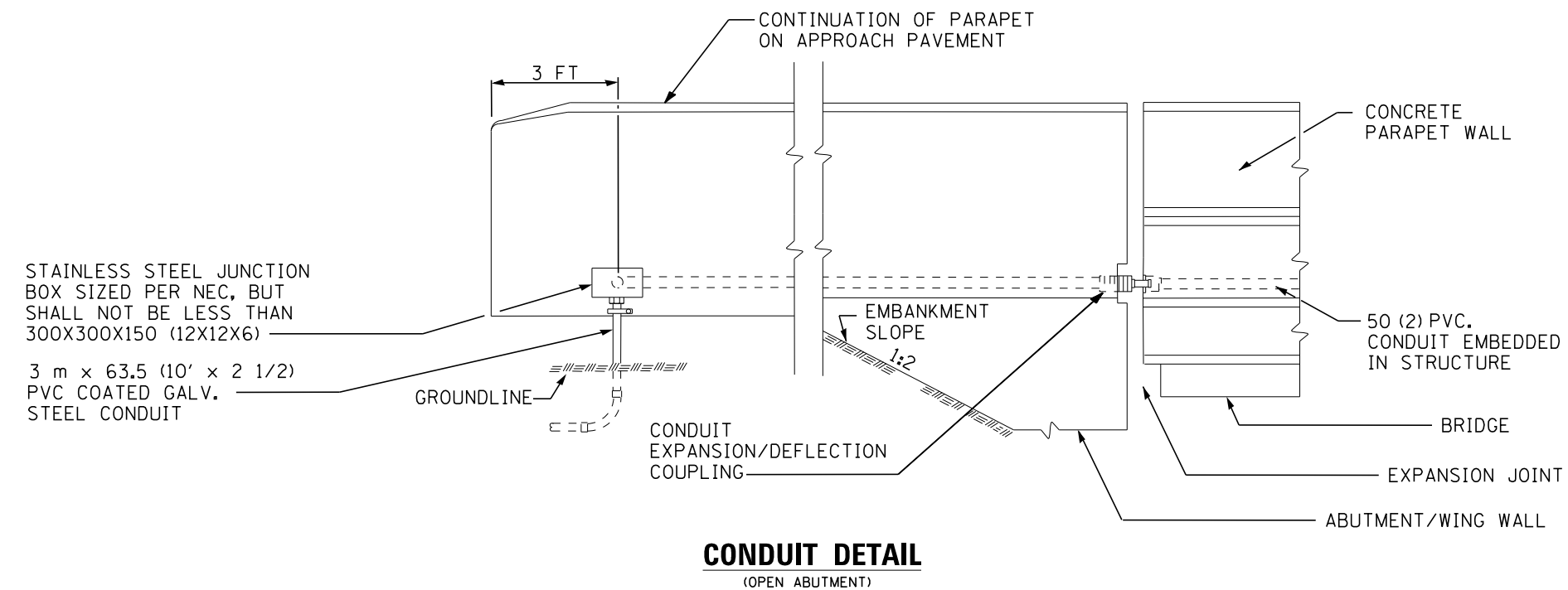
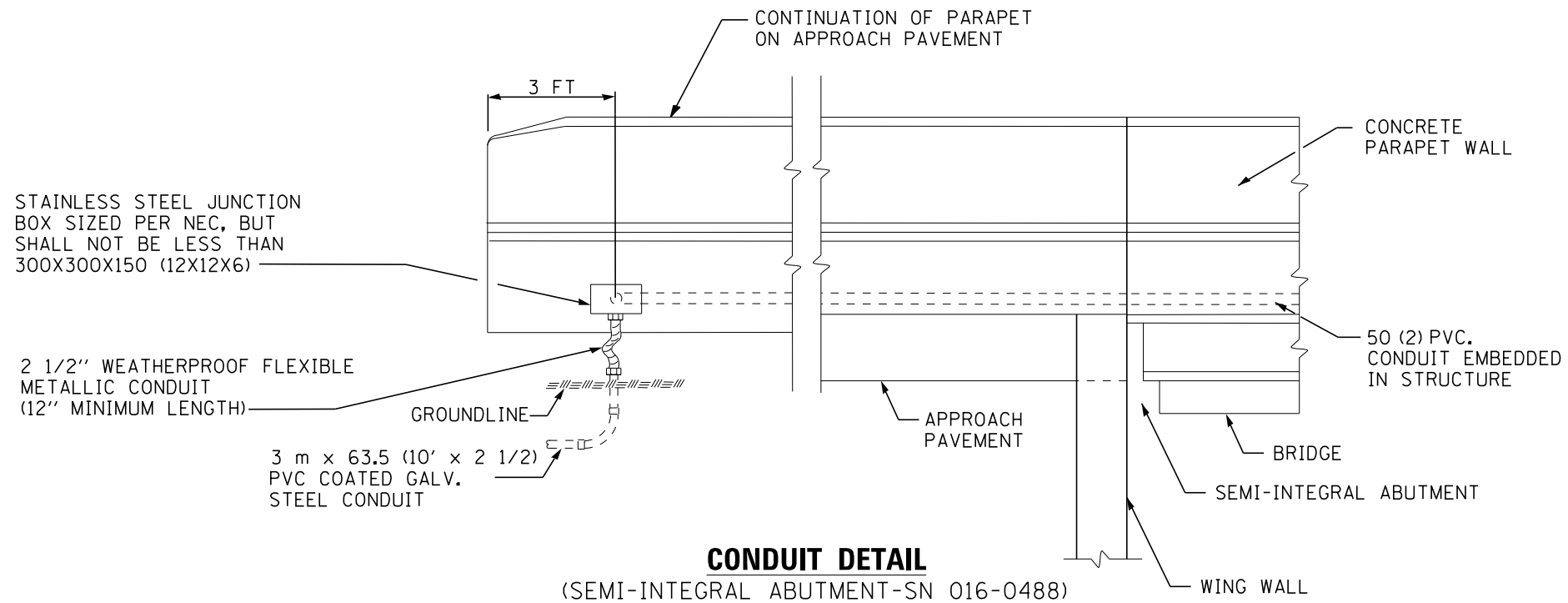

ALL DIMENSIONS ARE IN MILLIMETERS (INCHES)  
UNLESS OTHERWISE SHOWN.

|   |                  |           |
|---|------------------|-----------|
| FILE NAME =                                     | DESIGNED - GRR   | REVISED - |
| ...\\D160J16-sht-IL171-conduit-detail-SB-02.dgn | DRAWN - JLW      | REVISED - |
| USER NAME = tblank                              | CHECKED - GHT    | REVISED - |
| PLOT DATE = 8/7/2014                            | DATE - 6/23/2014 | REVISED - |



STATE OF ILLINOIS  
DEPARTMENT OF TRANSPORTATION

CONDUIT TRANSITION DETAILS

SCALE: SHEET 32 OF 49 SHEETS STA. TO STA.

| F.A.P. RTE.        | SECTION     | COUNTY | TOTAL SHEETS              | SHEET NO. |
|--------------------|-------------|--------|---------------------------|-----------|
| 372/373            | 2013-038B-R | COOK   | 821                       | 231       |
| CONTRACT NO. 60J16 |             |        | ILLINOIS FED. AID PROJECT |           |

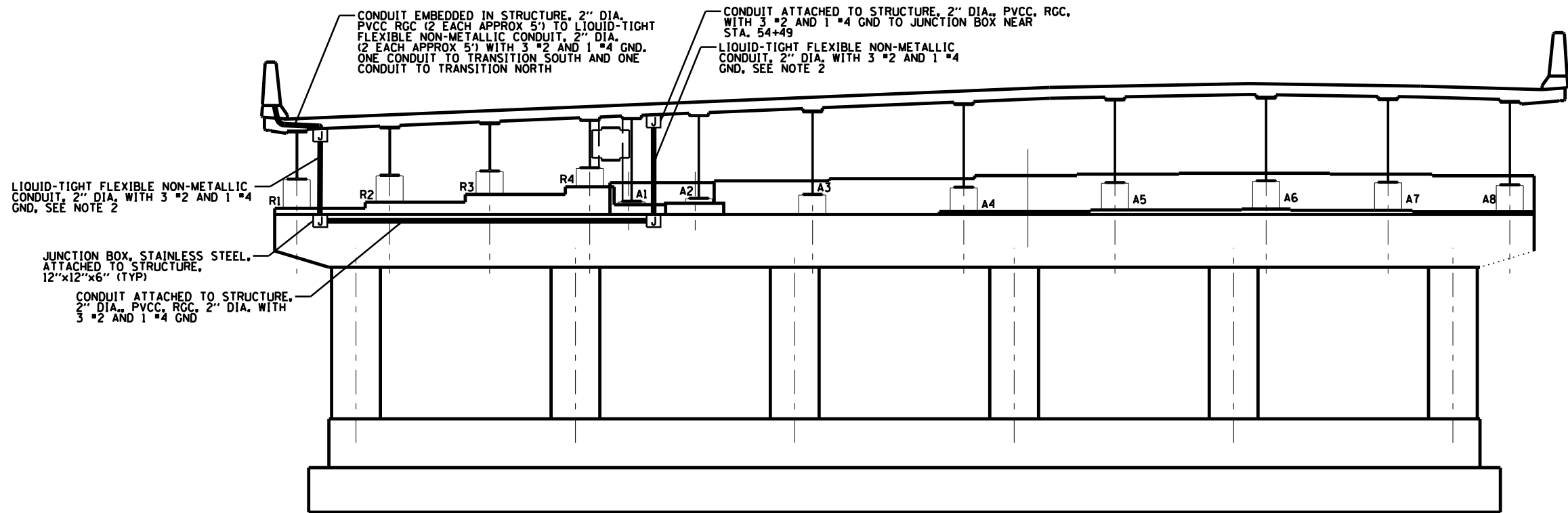

**CONDUIT TRANSITION DETAILS – ELEVATION AT PIER 7 –**  
**☉ BRG. PIER 7S**  
 N.T.S.

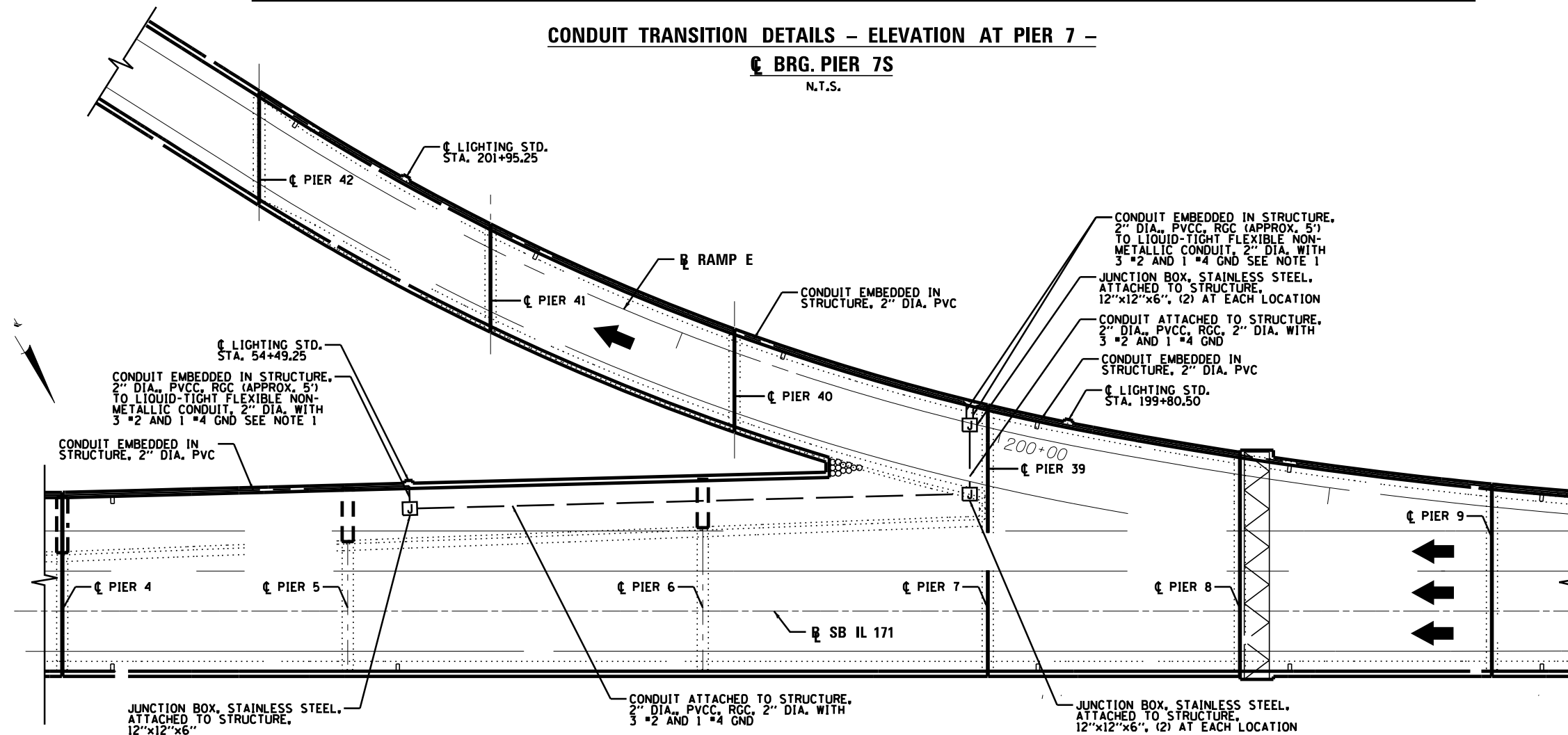

**CONDUIT TRANSITION DETAILS – PLAN VIEW**  
 N.T.S.

- NOTES:**
1. THESE CONDUITS FOR TRANSITIONING FROM 2" PVC EMBEDDED CONDUIT TO THE STAINLESS STEEL JUNCTION BOX SHALL BE INCLUDED IN THE COST OF THE 2" PVC EMBEDDED CONDUIT.
  2. THIS LIQUID-TIGHT CONDUIT SHALL BE INCLUDED IN THE COST OF THE 2" PVCC RGC ATTACHED TO STRUCTURE.

|   |                  |           |
|---|------------------|-----------|
| FILE NAME =                                     | DESIGNED - GRR   | REVISED - |
| ...\\D160J16-sht-IL171-conduit-detail-SB-03.dgn | DRAWN - JLW      | REVISED - |
| USER NAME = jworthington                        | CHECKED - GHT    | REVISED - |
| PLOT DATE = 6/23/2014                           | DATE - 6/23/2014 | REVISED - |



**STATE OF ILLINOIS**  
**DEPARTMENT OF TRANSPORTATION**

**CONDUIT TRANSITION DETAILS**

SCALE: SHEET 33 OF 49 SHEETS STA. TO STA.

|                    |             |        |                           |           |
|--------------------|-------------|--------|---------------------------|-----------|
| F.A.P. RTE.        | SECTION     | COUNTY | TOTAL SHEETS              | SHEET NO. |
| 372/373            | 2013-038B-R | COOK   | 821                       | 232       |
| CONTRACT NO. 60J16 |             |        | ILLINOIS FED. AID PROJECT |           |

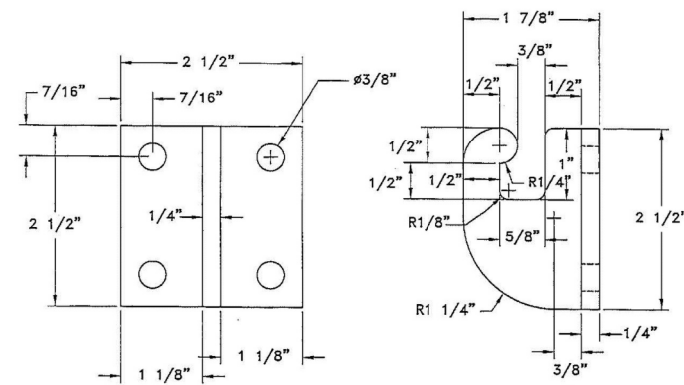

**CHAIN CLIPS**  
ONE PER SWIVEL REQUIRED

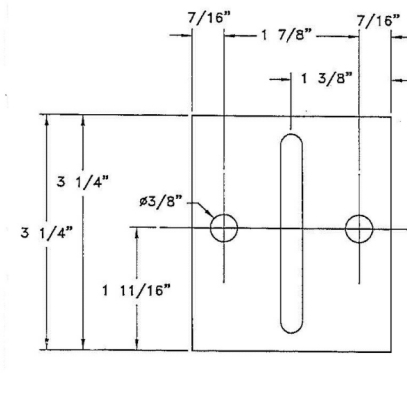

**CHAIN SUPPORT**  
ONE PER SWIVEL REQUIRED

**MATERIAL:**  
CARBON STEEL  
**FINISH:**  
HOT DIP GALVANIZED

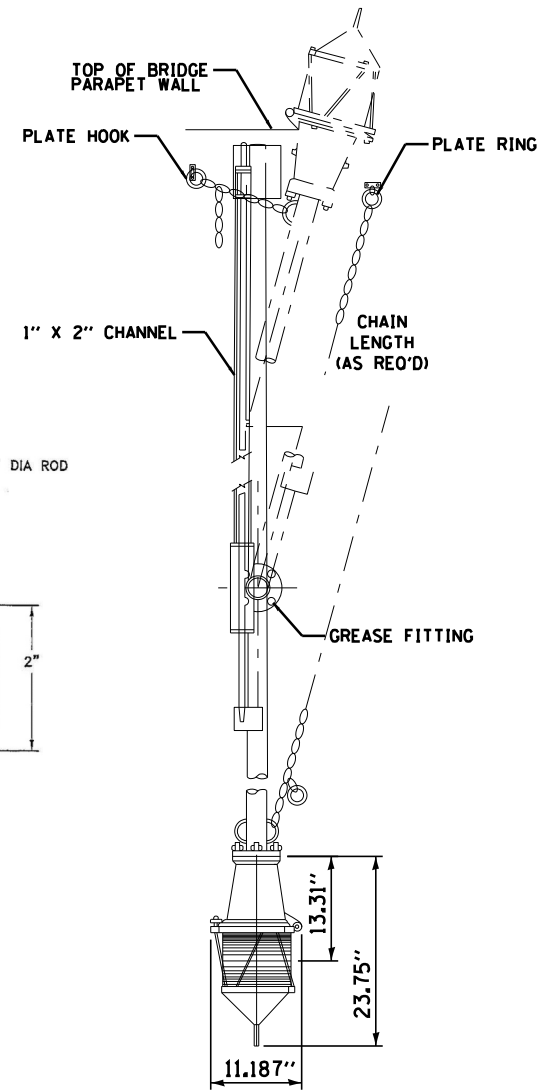
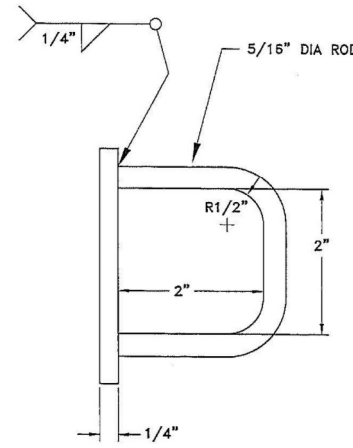

**NAVIGATION LUMINAIRE**

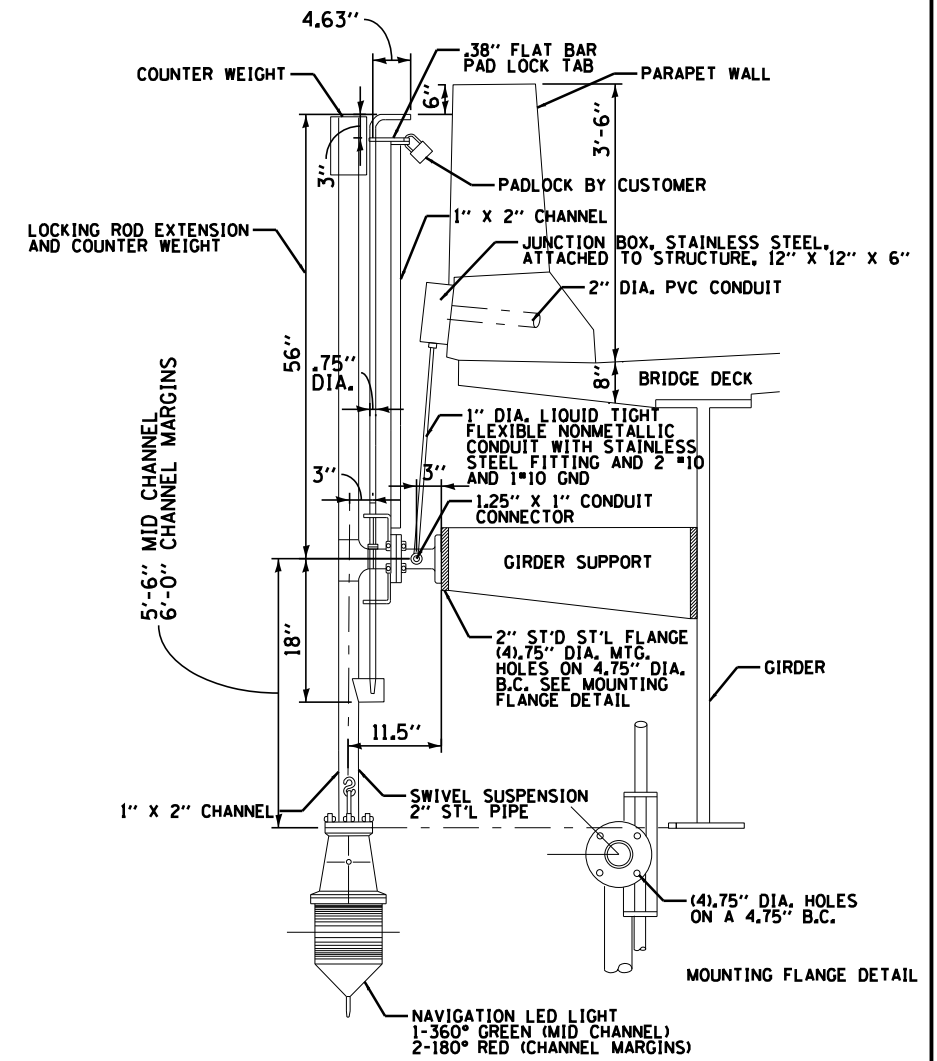

**NAVIGATION LIGHT FIXTURE AND LOCKING SWIVEL ASSEMBLY**

**NOTES:**

- ALL DIMENSIONS ARE IN INCHES UNLESS NOTED OTHERWISE. CONTRACTOR SHALL VERIFY DIMENSIONS IN FIELD PRIOR TO SUBMITTING SHOP DRAWINGS.
- THE CONTRACTOR SHALL SUBMIT SHOP DRAWINGS TO THE ENGINEER FOR APPROVAL OF THE NAVIGATION LIGHT ASSEMBLY.
- PLATE RING AND PLATE HOOK SHALL BE ATTACHED TO PARAPET WALL. SEE STRUCTURAL PLANS FOR PARAPET WALL DETAILS.
- FOR DIMENSIONS OF OTHER STRUCTURAL MEMBERS, REFER TO STRUCTURAL DRAWINGS.
- TOP OF NAVIGATION LIGHT HOUSING SHALL BE AT THE SAME ELEVATION AS THE BOTTOM OF ADJACENT GIRDER.
- LIQUID TIGHT CONDUIT AND CABLES FROM JUNCTION BOX TO NAVIGATION LIGHT SHALL BE INCLUDED IN THE COST OF THE NAVIGATION LIGHTING SYSTEM.

|                                     |                  |           |
|-------------------------------------|------------------|-----------|
| FILE NAME =                         | DESIGNED - GRR   | REVISED - |
| ...\\D160J16-sht-IL171-NavLight.dgn | DRAWN - JLW      | REVISED - |
| USER NAME = jworthington            | CHECKED - GHT    | REVISED - |
| PLOT DATE = 6/23/2014               | DATE - 6/23/2014 | REVISED - |



STATE OF ILLINOIS  
DEPARTMENT OF TRANSPORTATION

**NAVIGATION LIGHTING DETAILS**

SCALE: SHEET 34 OF 49 SHEETS STA. TO STA.

|                    |             |        |                           |           |
|--------------------|-------------|--------|---------------------------|-----------|
| F.A.P. RTE.        | SECTION     | COUNTY | TOTAL SHEETS              | SHEET NO. |
| 372/373            | 2013-038B-R | COOK   | 821                       | 233       |
| CONTRACT NO. 60J16 |             |        | ILLINOIS FED. AID PROJECT |           |

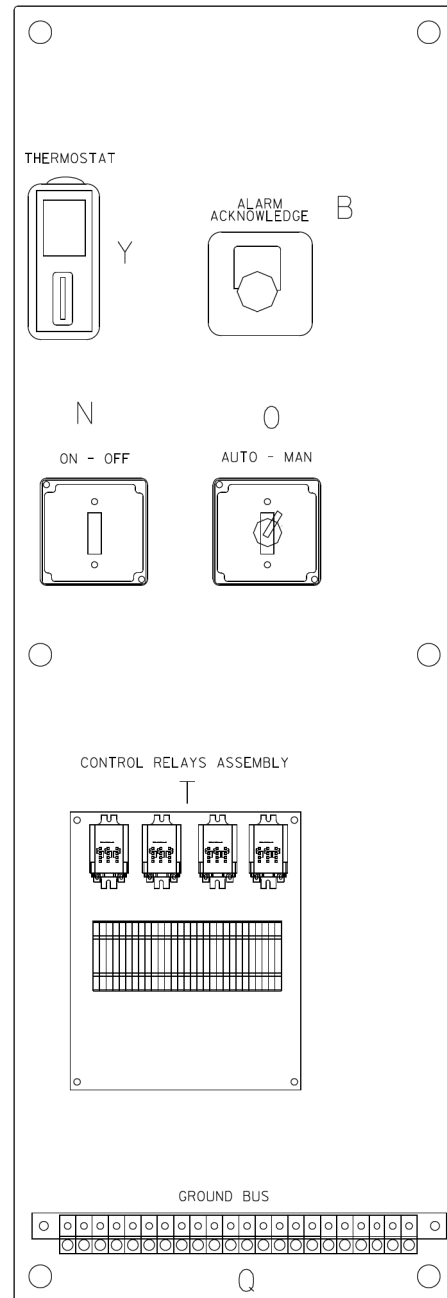
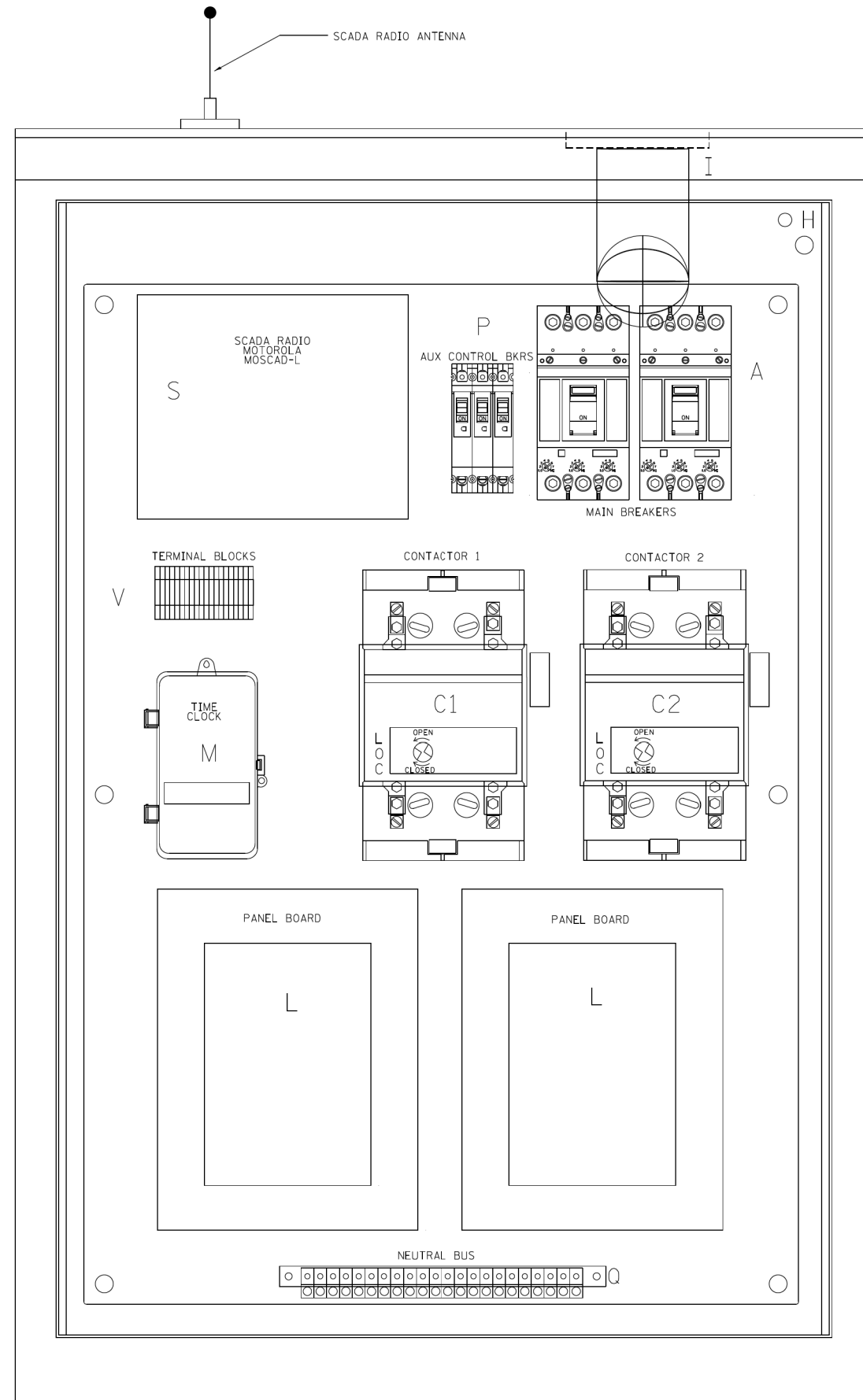

LEFT SIDE PANEL

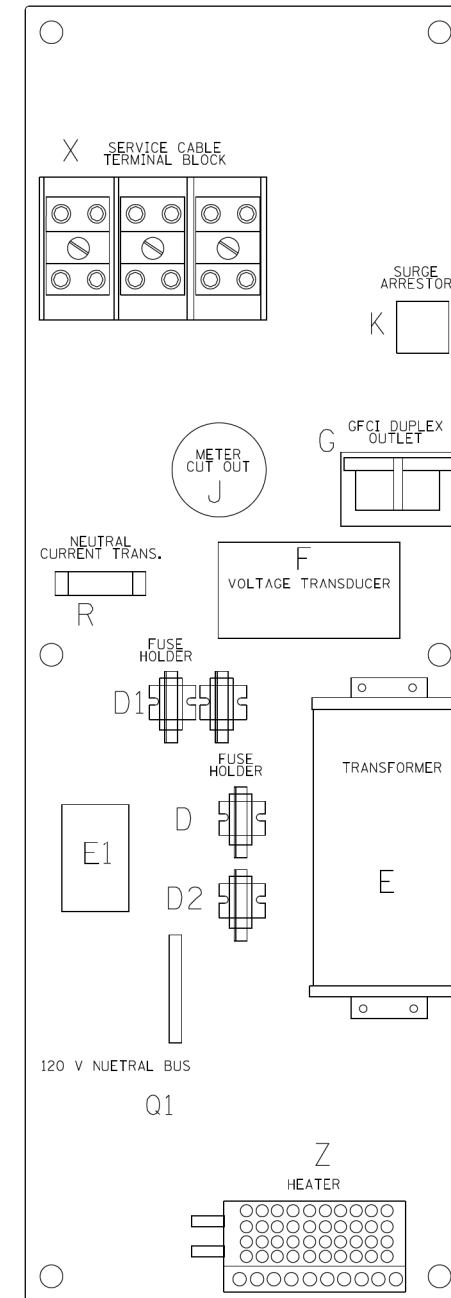

RIGHT SIDE PANEL

| BILL OF MATERIALS |     |   |
|-------------------|-----|---|
| ITEM              | QTY | DESCRIPTION   |
| A                 | 2   | MAIN CIRCUIT BREAKERS<br>2 POLE 200 AMP WITH AUX CONTACT  |
| B                 | 1   | ACKNOWLEDGE SWITCH, PUSH BUTTON WITH YELLOW INSERT  |
| C1, C2*           | 2   | CONTACTOR<br>2 POLE 200 AMP<br>240V COIL WITH AUX CONTACTS  |
| D                 | 1   | FINGERSAFE FUSE HOLDER WITH KTK-20 FUSE   |
| D1                | 2   | FINGERSAFE FUSE HOLDER WITH KTK-1/2 FUSE  |
| D2                | 1   | FINGERSAFE FUSE HOLDER WITH KTK-2A FUSE   |
| E                 | 1   | 2.0 KVA 277V-240/120<br>TRANSFORMER   |
| E1                | 1   | 0.25 KVA 240/120 - 24 VAC<br>TRANSFORMER  |
| F                 | 1   | VOLTAGE TRANSDUCER WITH COVERED TERMINALS   |
| G                 | 1   | 20 AMP GFCI DUPLEX OUTLET W/COVER   |
| H                 | 2   | DOOR SWITCH   |
| I                 | 1   | LIGHT FIXTURE   |
| J                 | 1   | METER FITTING<br>1 PHASE 3 WIRE 200 AMP   |
| K                 | 1   | SURGE ARRESTER  |
| L                 | 2   | PANEL BOARD<br>480/240V 1 PHASE, 250 AMP COPPER BUS   |
| M                 | 1   | 2 CHANNEL DIGITAL TIME CLOCK  |
| N                 | 1   | MOMENTARY SWITCH ON - OFF   |
| O                 | 1   | SQUARE D, 9001KS11BH3, 2 POSITION SWITCH IN<br>9001KY1 ENCLOSURE OR APPROVED EQUAL  |
| P                 | 2   | BREAKER 1P 15A  |
| Q                 | 2   | COPPER GROUND AND NEUTRAL BUS 1 x 16 x 1/4  |
| Q1                | 1   | COPPER NEUTRAL BUS WITH 1 #6 AND 8 #12<br>CONDUCTOR POINTS  |
| R                 | 1   | CURRENT TRANSDUCER  |
| S                 | 1   | MOTOROLA MOSCAD-L RADIO, 240 V  |
| T*                | 1   | CONTROL RELAY ASSEMBLY 240V COILS<br>WITH 4 3 PDT 25A RELAYS (W389ACX-15)<br>(R1, R2, R3, R4) . QTY 32<br>TERMINAL BLOCKS |
| V                 | 20  | TERMINAL BLOCKS   |
| X*                | 1   | 620 AMP SLPICE BLOCK  |
| Y                 | 1   | 40-80 DEG THERMOSTAT  |
| Z                 | 1   | 375 WATT HEATER   |

\* TERMINALS SHALL BE COVERED WITH CLEAR PLEXIGLASS SHEET

|   |                            |            |                               |
|---|----------------------------|------------|-------------------------------|
| FILE NAME =                                     | USER NAME = drivakosgn     | DESIGNED - | REVISED - R. TOMSONS 08-19-04 |
| ct:\pw\work\p\dot\drivakosgn\d0108315\bo205.dgn |                            | DRAWN -    | REVISED - R. TOMSONS 05-11-09 |
|   | PLOT SCALE = 50.000' / in. | CHECKED -  | REVISED - R. TOMSONS 03-10-10 |
|   | PLOT DATE = 3/29/2012      | DATE -     | REVISED - R. TOMSONS 03-29-12 |

STATE OF ILLINOIS  
DEPARTMENT OF TRANSPORTATION

LIGHTING CONTROLLER, BASE MOUNTED, 480VOLT, 200AMP (DUAL) RADIO SCADA

SCALE: NONE SHEET NO. 1 OF 4 SHEETS STA. TO STA.

|   |             |        |                    |           |
|---|-------------|--------|--------------------|-----------|
| F.A.P.<br>RTE.                                  | SECTION     | COUNTY | TOTAL SHEETS       | SHEET NO. |
| .   | 2013-038B-R | COOK   | 821                | 234       |
| BE-205  |             |        | CONTRACT NO. 60J16 |           |
| FED. ROAD DIST. NO. 1 ILLINOIS FED. AID PROJECT |             |        |                    |           |

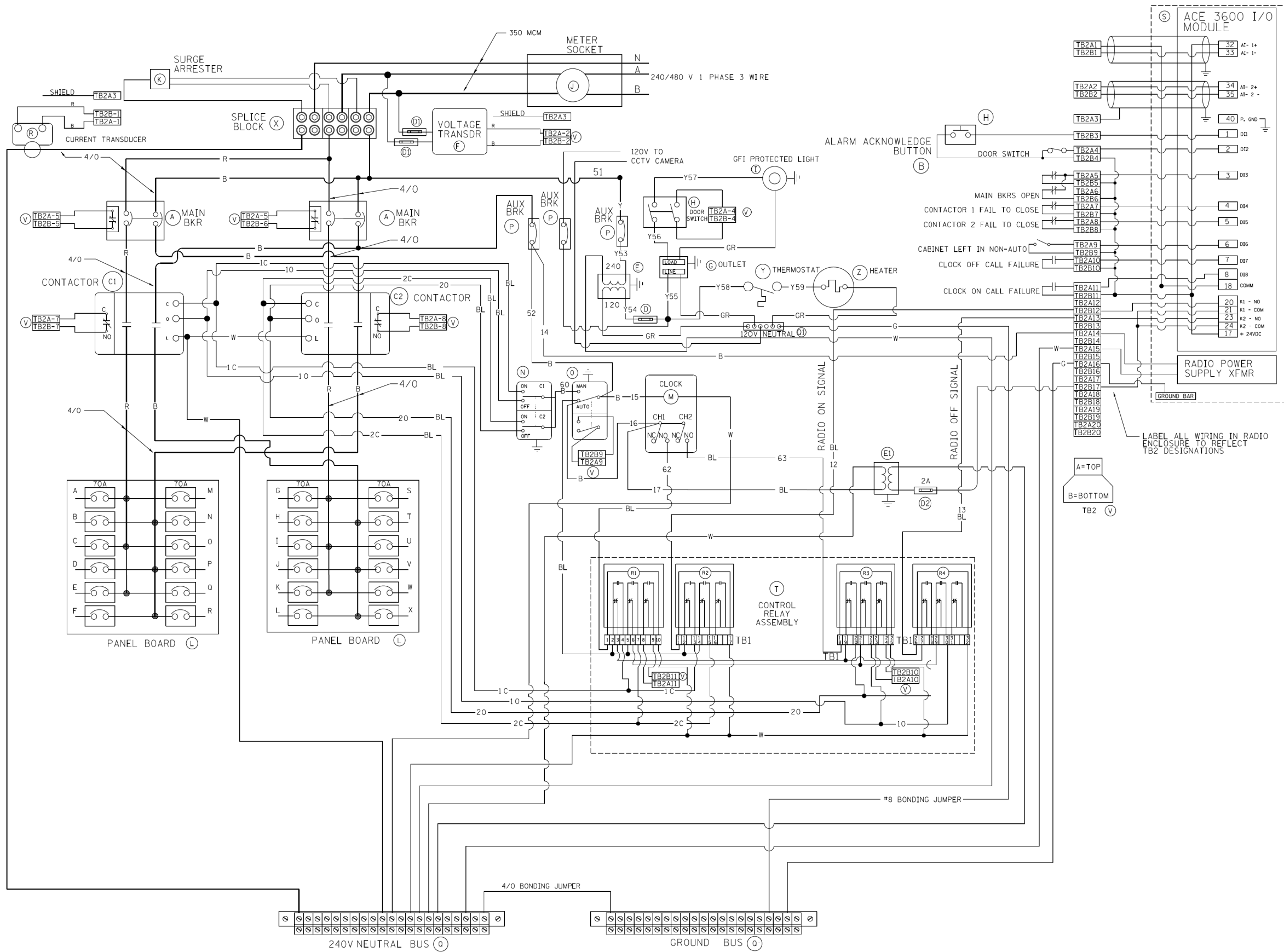

| BILL OF MATERIALS |     |   |
|-------------------|-----|---|
| ITEM #            | QTY | DESCRIPTION   |
| A                 | 2   | MAIN CIRCUIT BREAKERS<br>2 POLE 200 AMP WITH AUX CONTACT  |
| B                 | 1   | ACKNOWLEDGE SWITCH, PUSH BUTTON WITH YELLOW INSERT  |
| C1, C2            | 2   | CONTACTOR<br>2 POLE 200 AMP<br>240V COIL WITH AUX CONTACTS  |
| D                 | 1   | FINGERSAFE FUSE HOLDER WITH KTK-20A FUSE  |
| D1                | 2   | FINGERSAFE FUSE HOLDER WITH KTK-1/2 FUSE  |
| D2                | 1   | FINGERSAFE FUSE HOLDER WITH KTK- 2A FUSE  |
| E                 | 1   | 2.0 KVA 277V-240/120<br>TRANSFORMER   |
| E1                | 1   | 0.25 KVA 240/120-24 VAC<br>TRANSFORMER  |
| F                 | 1   | VOLTAGE TRANSDUCER  |
| G                 | 1   | 15 AMP GFCI DUPLEX OUTLET W/COVER   |
| H                 | 2   | DOOR SWITCH A-20G0-B7-K   |
| I                 | 1   | LIGHT FIXTURE   |
| J                 | 1   | METER FITTING<br>1 PHASE 3 WIRE 200 AMP   |
| K                 | 1   | SURGE ARRESTER  |
| L                 | 2   | PANEL BOARD<br>480/240V 1 PHASE, 250 AMP COPPER BUS   |
| M                 | 1   | 2 CHANNEL DIGITAL TIME CLOCK  |
| N                 | 1   | MOMENTARY SWITCH ON - OFF   |
| O                 | 1   | SQUARE D, 900IKS11BH13, 2 POSITION SWITCH IN<br>900IKY1 ENCLOSURE   |
| P                 | 2   | BREAKER 1P 15A  |
| Q                 | 2   | COPPER GROUND AND NEUTRAL BUS 1 x 16 x 1/4  |
| Q1                | 1   | COPPER NEUTRAL BUS WITH 1 1/0 AND #6<br>CONDUCTOR POINTS  |
| R                 | 1   | CURRENT TRANSDUCER  |
| S                 | 1   | MOTOROLA ACE 3600   |
| T                 | 1   | CONTROL RELAY ASSEMBLY 240V COILS<br>WITH 4 3 PDT 25A RELAYS (W389ACX-15)<br>(R1, R2, R3, R4) . QTY 32<br>TERMINAL BLOCKS |
| V                 | 20  | TERMINAL BLOCKS   |
| X                 | 1   | 620 AMP SPLICE BLOCK  |
| Y                 | 1   | 40-80 DEG THERMOSTAT  |
| Z                 | 1   | 375 WATT HEATER   |

|   |                        |            |                               |
|---|------------------------|------------|-------------------------------|
| FILE NAME =                                   | USER NAME = drivakosgn | DESIGNED - | REVISED - R. TOMSONS 08-19-04 |
| ca:\pwork\pwork\drivakosgn\d0108315\bd205.dgn |                        | DRAWN -    | REVISED - R. TOMSONS 05-11-09 |
| PLOT SCALE = 50.000' / in.                    |                        | CHECKED -  | REVISED - R. TOMSONS 03-10-10 |
| PLOT DATE = 3/29/2012                         |                        | DATE -     | REVISED - R. TOMSONS 03-29-12 |

**STATE OF ILLINOIS  
DEPARTMENT OF TRANSPORTATION**

**LIGHTING CONTROLLER, BASE MOUNTED, 480VOLT, 200AMP (DUAL) RADIO SCADA**

SCALE: NONE    SHEET NO. 2 OF 4 SHEETS    STA.    TO STA.

|   |               |              |              |           |
|---|---------------|--------------|--------------|-----------|
| F.A. P. RTE.                                    | SECTION       | COUNTY       | TOTAL SHEETS | SHEET NO. |
| .   | 2013-038B-R   | COOK         | 821          | 235       |
|   | <b>BE-205</b> | CONTRACT NO. | <b>60J16</b> |           |
| FED. ROAD DIST. NO. 1 ILLINOIS FED. AID PROJECT |               |              |              |           |

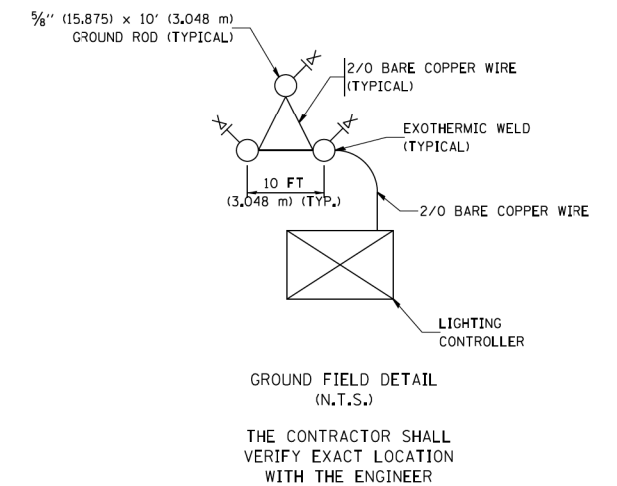
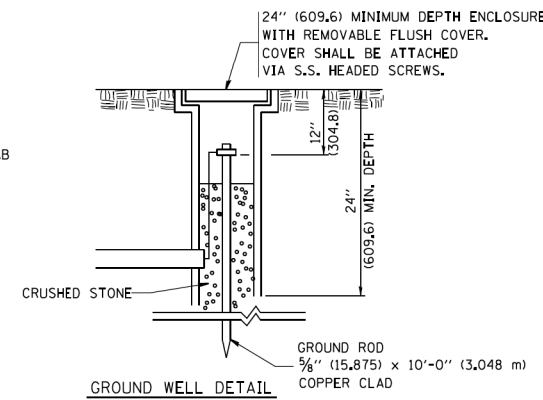
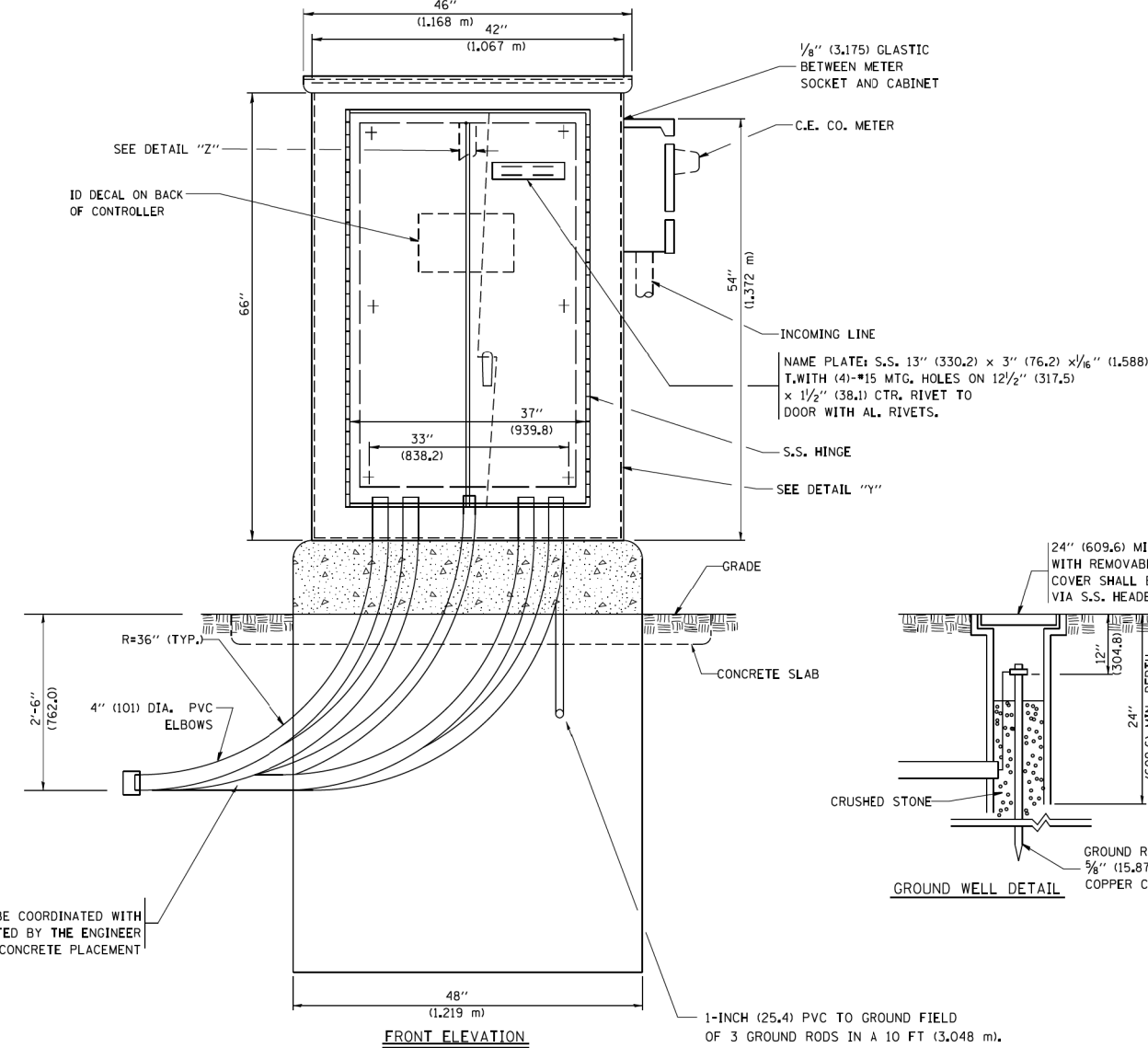
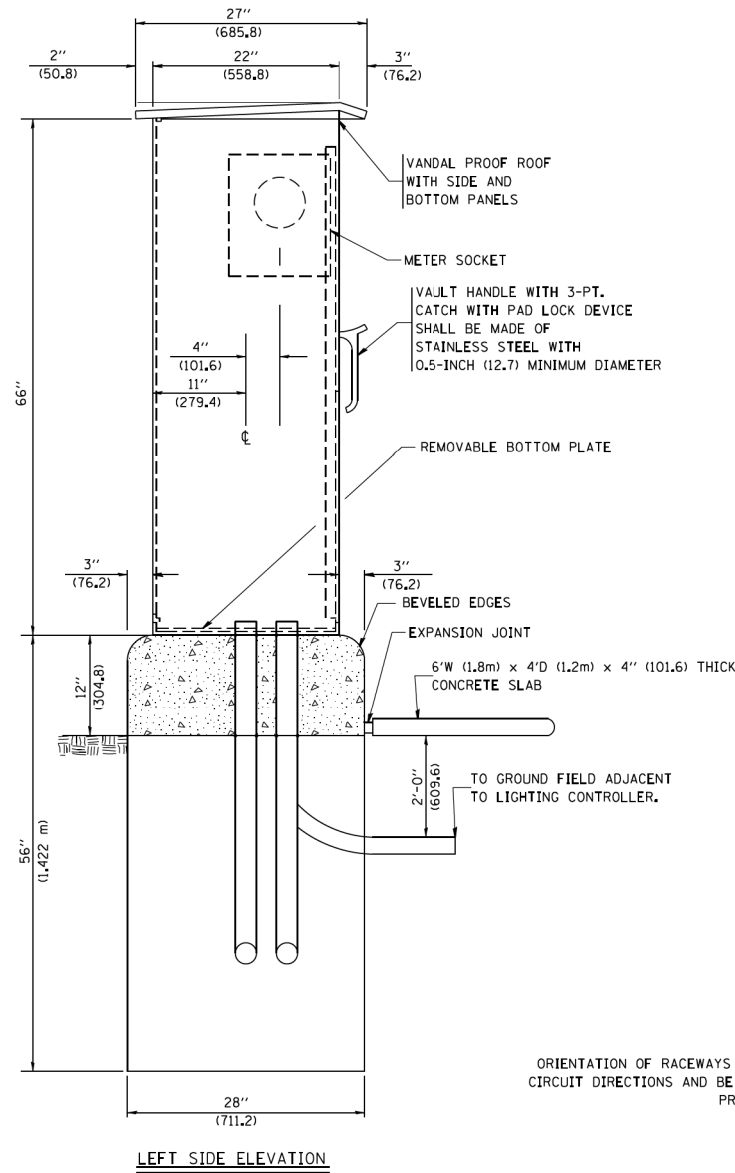
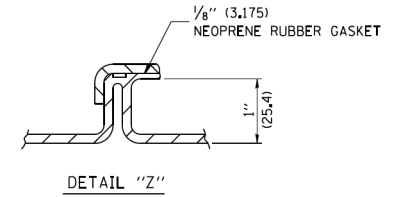
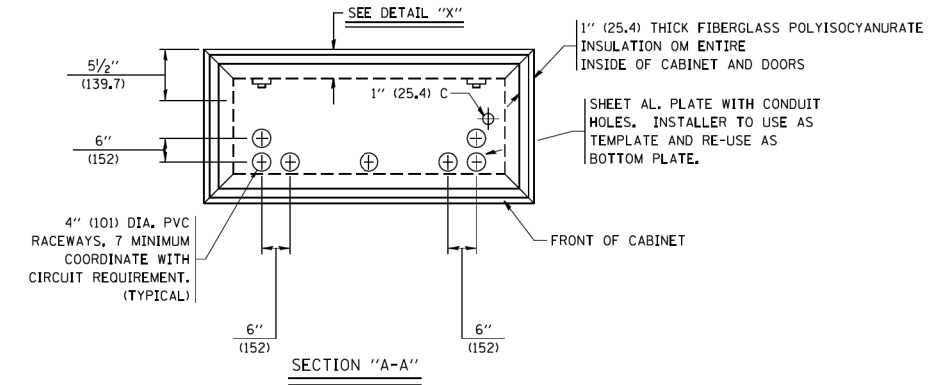
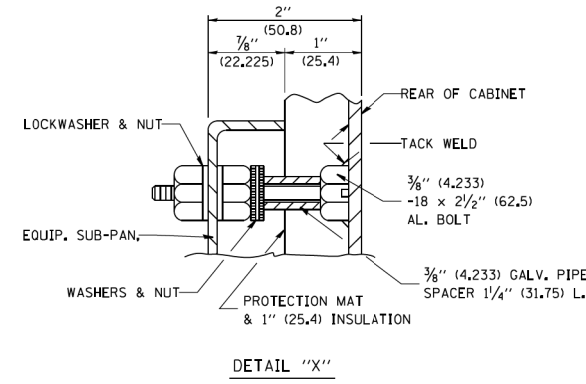
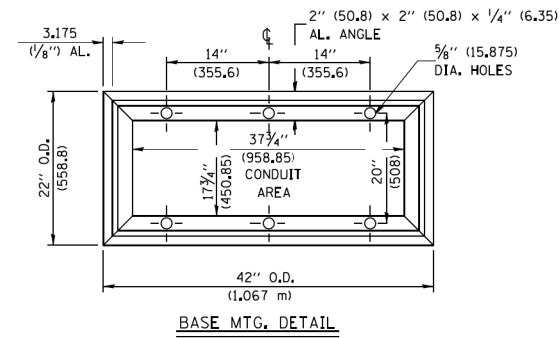
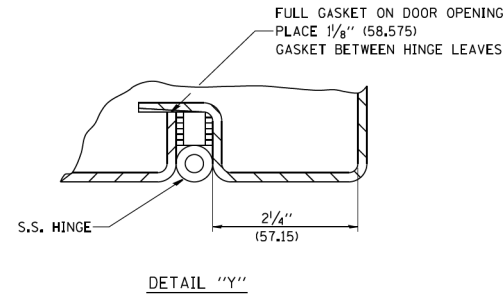

ORIENTATION OF RACEWAYS SHALL BE COORDINATED WITH CIRCUIT DIRECTIONS AND BE INSPECTED BY THE ENGINEER PRIOR TO CONCRETE PLACEMENT

1-INCH (25,4) PVC TO GROUND FIELD OF 3 GROUND RODS IN A 10 FT (3,048 m) TRIANGLE CONNECTED VIA BARE COPPER WIRE. VERIFY EXACT LOCATION OF GROUND FIELD WITH THE ENGINEER. NO GROUND WELL SHALL BE PLACED IN CONCRETE PAD IN FRONT OF CONTROLLER.

|   |                        |                             |                               |   |  |                         |      |             |   |              |              |           |
|---|------------------------|-----------------------------|-------------------------------|---|--|-------------------------|------|-------------|---|--------------|--------------|-----------|
| FILE NAME =                                   | USER NAME = drivakosgn | DESIGNED -                  | REVISED - R. TOMSONS 08-19-04 | <b>STATE OF ILLINOIS<br/>DEPARTMENT OF TRANSPORTATION</b> | <b>LIGHTING CONTROLLER, BASE MOUNTED, 480VOLT, 200AMP (DUAL) RADIO SCADA</b> |                         |      | F.A.P. RTE. | SECTION   | COUNTY       | TOTAL SHEETS | SHEET NO. |
| ca:\pwork\pwork\drivakosgn\d0108315\be205.dgn |                        | DRAWN -                     | REVISED - R. TOMSONS 05-11-09 |   |  |                         |      |             | 2013-038B-R                                     | COOK         | 821          | 236       |
|   |                        | PLOT SCALE = 50.000 ' / in. | REVISED - R. TOMSONS 03-10-10 |   |  |                         |      |             | BE-205  | CONTRACT NO. | 60J16        |           |
|   |                        | PLOT DATE = 3/29/2012       | REVISED - R. TOMSONS 03-29-12 |   |  |                         |      |             | FED. ROAD DIST. NO. 1 ILLINOIS FED. AID PROJECT |              |              |           |
|   |                        |                             |                               |   | SCALE: NONE  | SHEET NO. 3 OF 4 SHEETS | STA. | TO STA.     |   |              |              |           |



NOTES

- CABINET SHALL BE FABRICATED FROM 0.125-INCH (3.175) SHEET ALUMINUM #3003H14, FORMED AND ARC WELDED.
- ALL SCREWS AND HARDWARE SHALL BE PLATED, GALVANIZED, OR MADE OF BRASS, ALUMINUM OR STAINLESS STEEL, UNLESS OTHERWISE NOTED.
- NAME PLATE SHALL HAVE ENGRAVED 0.75-INCH (19.05) HIGH LETTERS FILLED IN BLACK: "STATE OF ILLINOIS LIGHTING CONTROLS" UNLESS OTHERWISE SPECIFIED.
- ONE INCH THICK POLYISOCYANURATE INSULATION SHALL BE INSTALL AND PERMANENTLY CEMENTED ON ALL SIDES OF THE CABINET AND DOORS.
- CABINET SHALL BE PRIMED AND PAINTED AS SPECIFIED.
- ELECTRIC UTILITY METER BOX SHALL BE MOUNTED ON THE SIDE OF CONTROL CABINET AS SHOWN ON THE PANEL LAYOUT DIAGRAM.
- THE COMPLETED CONTROLLER SHALL BE U.L. LISTED AS AN INDUSTRIAL CONTROL PANEL UNDER UL508.
- METAL MOUNTING PANEL SHALL BE FABRICATED FROM THE SAME MATERIAL AS THE CABINET AND SHALL BE FLANGED BACK 0.75-INCHES I.D. ON 4 SIDES.
- CIRCUIT BREAKERS AND CONTACTORS AND OTHER COMPONENTS SHALL BE MOUNTED ON 0.125-INCH (3.175) THICK GLASTIC INSULATION BACK PANEL.
- ALL DEVICES SHALL BE FRONT REMOVABLE.
- TIME CLOCK CHANNEL 1 N.O. CONTACT IS CLOSED NIGHT AND OPEN DAY (LIGHTS ON).
- SET LATITUDE TO 42 DEGREES, SET CH.1 TO 23 MINUTES AFTER ASTRONOMICAL SUNSET, 50 MINUTES BEFORE ASTRONOMICAL SUNRISE, SET CH.2 TO 60 MINUTES AFTER ASTRONOMICAL SUNSET (WITH A SIGNAL LENGTH OF 1 SECOND), +28 MINUTES AFTER ASTRONOMICAL SUNRISE (WITH A SIGNAL LENGTH OF 7 SECONDS.)
- BUS BAR SHALL HAVE 22 LUG TERMINALS SIZED TO ACCOMMODATE REQUIRED WIRE SIZES. 240V NEUTRAL BUS SHALL BE PAINTED WHITE, GROUND BUS SHALL BE PAINTED GREEN, AND THE 120V NEUTRAL BUS SHALL BE PAINTED GREY.
- ALL LUGS SHALL BE OF COPPER SCREWS AND CONNECTORS, SPRING HELD.
- ALL WIRING TERMINATIONS SHALL BE RATED NOT LESS THAN 75 DEGREE CENTIGRADE.
- ALL CONTROL WIRING SHALL BE 600V #12 TYPE MTW, SCADA WIRING SHALL BE #18.
- ALL POWER WIRING SHALL BE 600V TYPE RHH/RHW.
- ALL WIRING WITHIN THE CABINET SHALL BE COLOR CODED AS INDICATED:
 

|           |            |
|-----------|------------|
| R - RED   | Y - YELLOW |
| B - BLACK | W - WHITE  |
| BL - BLUE | G - GREEN  |
|           | GR - GREY  |
- MOSCAD I/O WIRING SHALL BE:
  - DIGITAL INPUT (DI) WIRING SHALL BE #18 MTW PURPLE.
  - ANALOG INPUT (AI) WIRING SHALL BE #18, 2/C SHIELDED.
  - AI AND DI WIRING MAY BE BUNDLED TOGETHER, BUT SHALL NOT BE BUNDLED WITH OTHER WIRING.
- ALL DIMENSIONS ARE IN INCHES (MILLIMETERS) UNLESS OTHERWISE INDICATED.
- SCHEMATIC SHOWN WITH BREAKER OPEN, CONTACTOR OPEN, CABINET DOOR CLOSED, CLOCK NOT ACTIVE (DE-ENERGIZED STATE).
- A LAMINATED COPY OF THE CIRCUIT SCHEMATIC AND SCADA I/O DIAGRAM (NO SMALLER THAN 11"x17" EACH) SHALL BE ATTACHED TO THE INSIDE OF THE CONTROLLER WITH STAINLESS STEEL SCREWS.

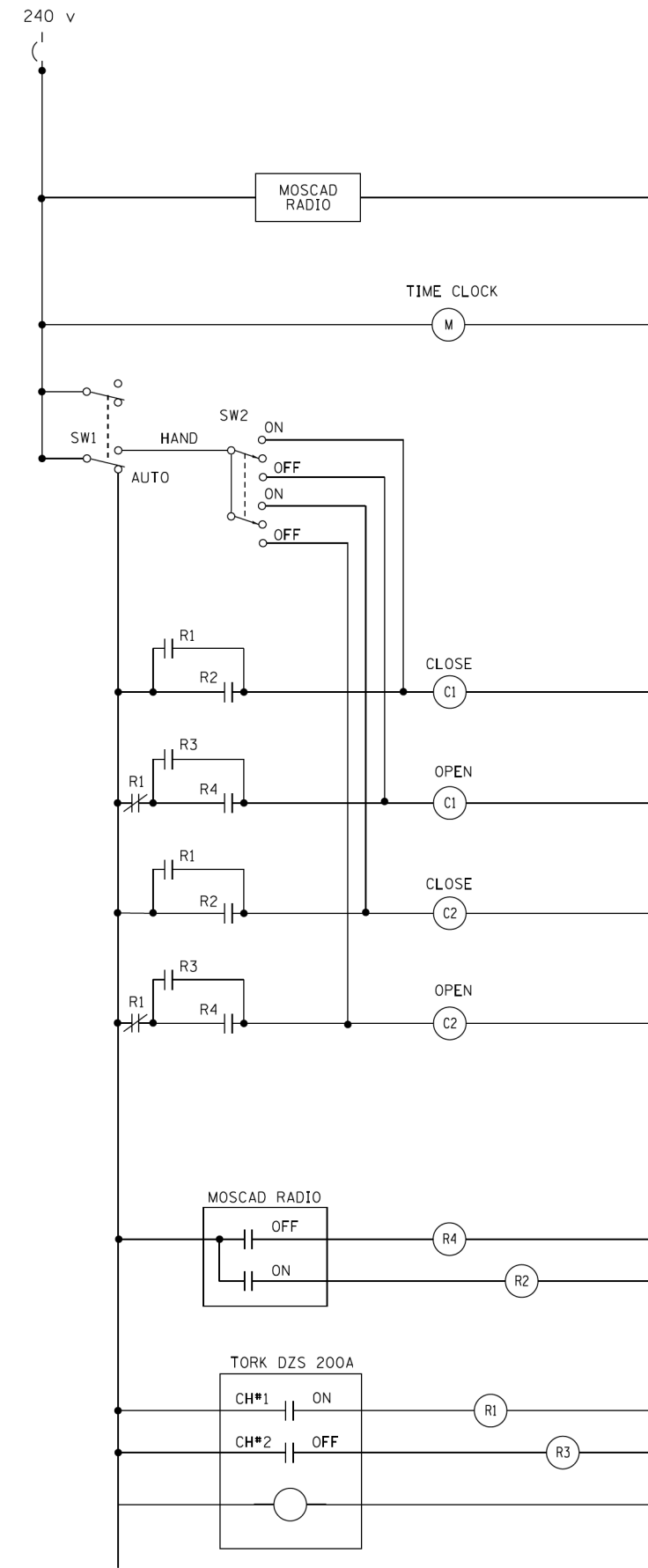

CONTROL CIRCUIT LADDER LOGIC DIAGRAM

| MOSCAD I/O ASSIGNMENTS |                    |                         |
|------------------------|--------------------|-------------------------|
| TERM                   | MOSCAD DESTINATION | DESCRIPTION OF INPUT    |
| 1                      | DIGITAL INPUT 1    | ALARM KNOWLEDGE         |
| 2                      | DIGITAL INPUT 2    | DOOR OPEN               |
| 3                      | DIGITAL INPUT 3    | MAINS) BREAKER OPEN     |
| 4                      | DIGITAL INPUT 4    | CONTACTOR 1 OPEN        |
| 5                      | DIGITAL INPUT 5    | CONTACTOR 2 OPEN        |
| 6                      | DIGITAL INPUT 6    | CABINET IN NON-AUTO     |
| 7                      | DIGITAL INPUT 7    | BACK-UP CLOCK OFF CALL  |
| 8                      | DIGITAL INPUT 8    | BACK-UP CLOCK ON CALL   |
| 17                     | 24 V+              | 24+VDC                  |
| 18                     | DI COMMON          | COMMON                  |
| 21                     | K1 C               | K1 COMMON               |
| 22                     | K1 NO              | LIGHTS ON CALL          |
| 24                     | K2 C               | K2 COMMON               |
| 25                     | K2 NO              | LIGHTS OFF CALL         |
| 32                     | ANALOG INPUT 1 (+) | CABINET NEUTRAL CURRENT |
| 33                     | ANALOG INPUT 1 (-) | CABINET NEUTRAL CURRENT |
| 34                     | ANALOG INPUT 2 (+) | CABINET SERVICE VOLTAGE |
| 35                     | ANALOG INPUT 2 (-) | CABINET SERVICE VOLTAGE |
| 40                     | P. GROUND          | GROUND                  |

ALL ANALOG INPUTS WILL BE 4-20 MA ONLY. DIGITAL OUTPUT RELAYS WILL BE ELECTRICALLY ENERGIZED AND MOMENTARILY HELD  
MIXED I/O MODULE MODEL NUMBER V436

|  |                            |            |                               |
|--|----------------------------|------------|-------------------------------|
| FILE NAME =                                  | USER NAME = drivkosgn      | DESIGNED - | REVISED - R. TOMSONS 08-19-04 |
| ca:\pwork\pwork\drivkosgn\d0108315\br205.dgn |                            | DRAWN -    | REVISED - R. TOMSONS 05-11-09 |
|  | PLOT SCALE = 50.000' / in. | CHECKED -  | REVISED - R. TOMSONS 03-10-10 |
|  | PLOT DATE = 3/29/2012      | DATE -     | REVISED - R. TOMSONS 03-29-12 |

STATE OF ILLINOIS  
DEPARTMENT OF TRANSPORTATION

LIGHTING CONTROLLER, BASE MOUNTED, 480VOLT, 200AMP (DUAL) RADIO SCADA

SCALE: NONE SHEET NO. 4 OF 4 SHEETS STA. TO STA.

|   |             |                    |              |           |
|---|-------------|--------------------|--------------|-----------|
| F.A.P. RTE.                                     | SECTION     | COUNTY             | TOTAL SHEETS | SHEET NO. |
|   | 2013-038B-R | COOK               | 821          | 237       |
| BE-205  |             | CONTRACT NO. 60J16 |              |           |
| FED. ROAD DIST. NO. 1 ILLINOIS FED. AID PROJECT |             |                    |              |           |

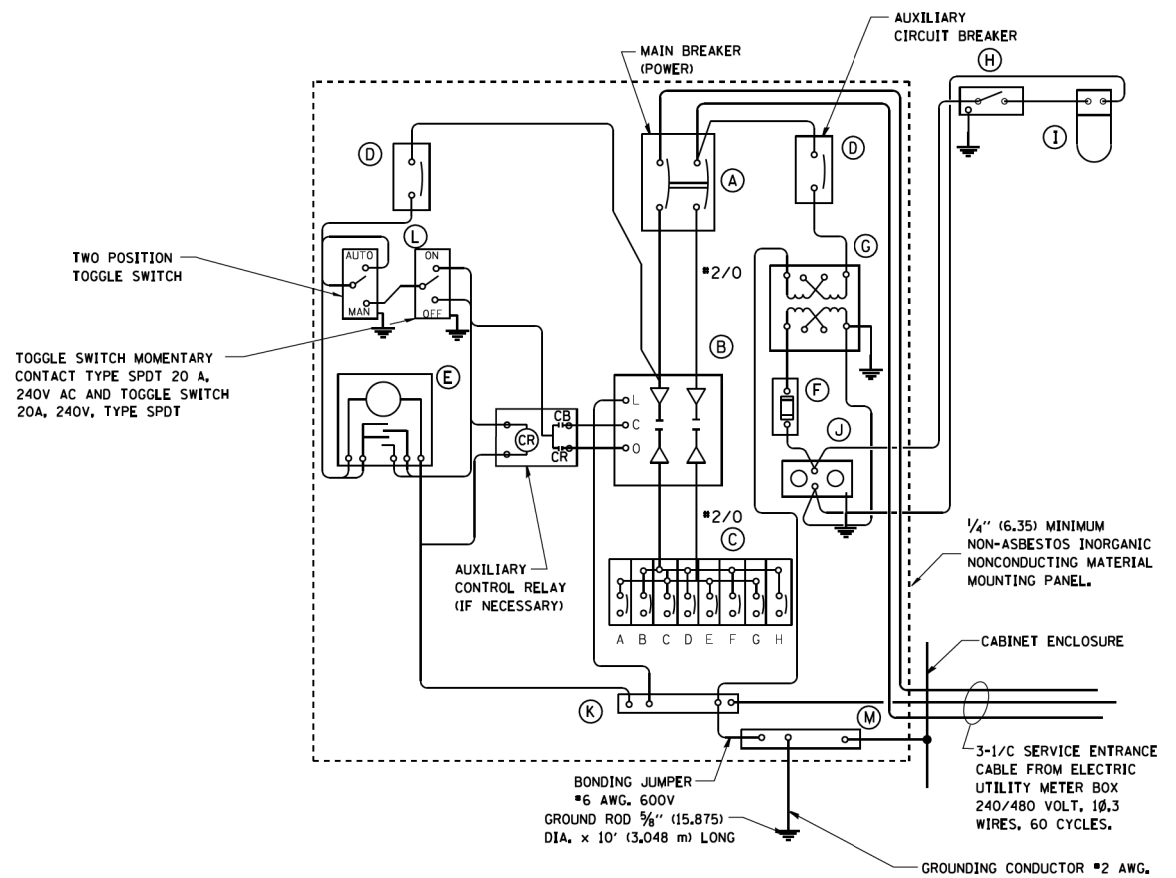

**PANEL WIRING DIAGRAM**

**PANEL EQUIPMENT**

| BILL OF MATERIAL |          |  |
|------------------|----------|--|
| ITEM             | QUANTITY | DESCRIPTION  |
| A                | 1        | MAIN CIRCUIT BREAKER, 2 POLE, 600 VOLT 100 AMP. FRAME, 100 AMP. NON-INTERCHANGEABLE TRIP INTERRUPTING RATING NEMA-22000 AMP. AT 480 VOLT.      |
| B                | 1        | REMOTE CONTROL SWITCH, ELECTRICALLY OPERATED, MECHANICALLY HELD, 2 POLE, SINGLE THROW, 100 AMP., 600 VOLTS CONTROL CIRCUIT 240 VOLT.           |
| C                | 8        | CIRCUIT BREAKERS, 1 POLE, 100AMP. FRAME, 50 AMP. NON-INTERCHANGEABLE TRIP INTERRUPTING RATING NEMA-10,000 AMP. AT 240 V.                       |
| D                | 2        | CONTROL CIRCUIT-CIRCUIT BREAKER, 1 POLE, 240 V., 100 AMP. FRAME, 15 AMP. NON-INTERCHANGEABLE TRIP INTERRUPTING RATING NEMA-5000 AMP. AT 240 V. |
| E                | 1        | ASTRONOMIC MICROPROCESSOR-BASED 2-CHANNEL CONTROLLER [TIME SWITCH].  |
| F                | 1        | 20 A., 120 V. FUSE.  |
| G                | 1        | 1.5 KVA, SINGLE PHASE, ENCAPSULATED TRANSFORMER 240 X 480 / 120 X 240 VOLT, 60 HZ.   |
| H                | 1        | SPST 20A SWITCH ON DOOR, TO TURN LIGHT ON WHEN DOOR IS OPEN,   |
| I                | 1        | INCANDESCENT LIGHTING FIXTURE ENCLOSED AND GASKETED WITH 60 WATT, 120 V. LAMP.   |
| J                | 1        | 20 A., 120 V., DUPLEX RECEPTACLE, GFCI.  |
| K                | 1        | COPPER GROUND BUS 1/4" (6.35) X 1" (25.4) X 12" (304.8 mm) LONG MOUNTED ON PANEL WITH LUGS AND 4 SPARE LUGS                                    |
| L                | 1        | TOGGLE SWITCHES MOUNTED IN 4" (101.6) X 4" (101.6 mm) BOX.   |
| M                | 1        | COPPER GROUND BUS 1/4" (6.35) X 1" (25.4) X 12" (304.8 mm) LONG MOUNTED ON PANEL WITH LUGS AND SPARE LUGS                                      |

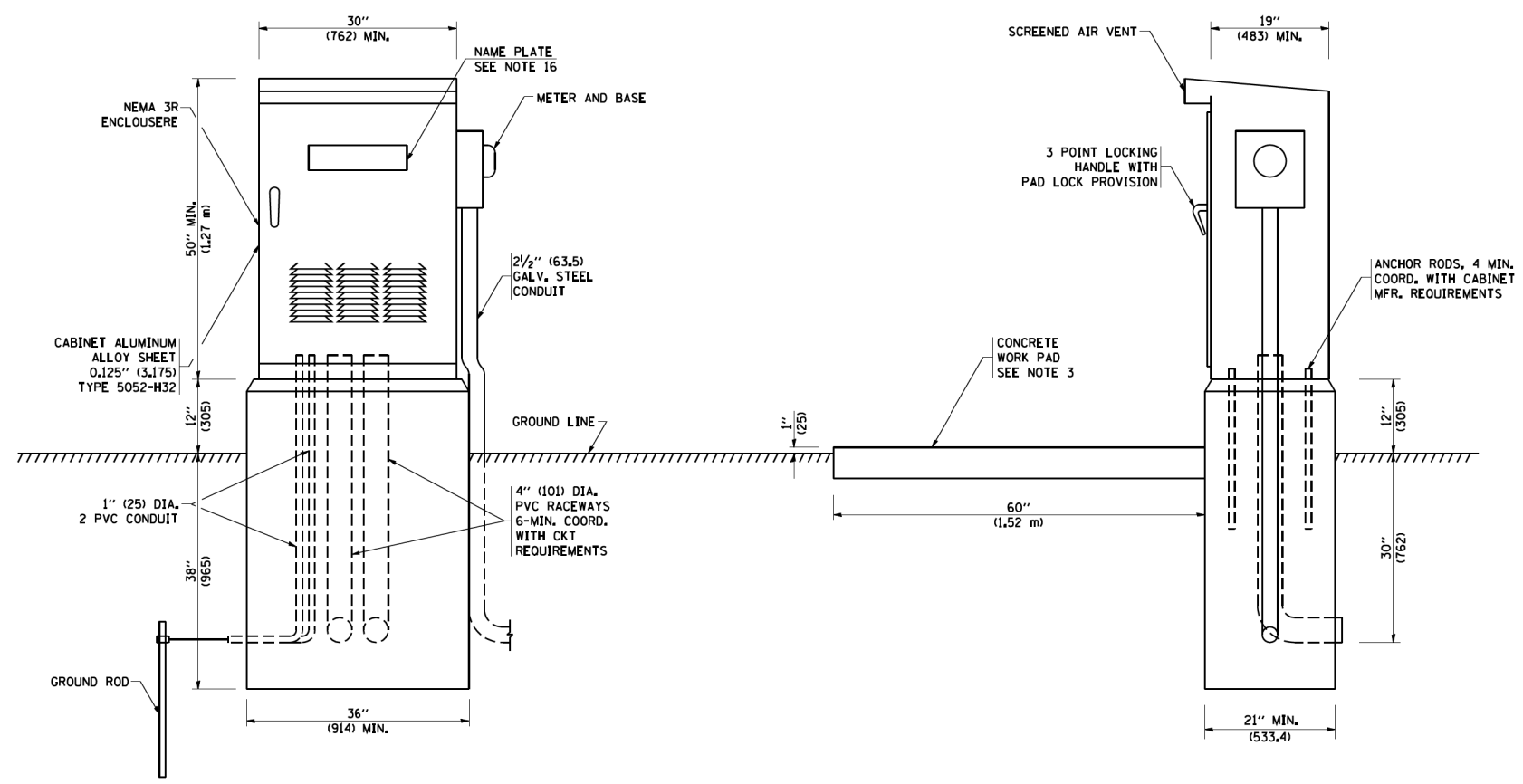

**NOTES:**

- ALL DIMENSIONS ARE IN INCHES (MILLIMETERS) UNLESS OTHERWISE SHOWN.
- FOUNDATION SIZE SHALL BE COORDINATED WITH CABINET SIZE AND MFR.
- IN FRONT OF CONTROL CABINET DOOR, REMOVE VEGETATION AND 2" (50.8 mm) TOP SOIL. LEVEL THE AREA AND ON TOP, PLACE LENGTH WISE PARALLEL TO CONTROL CABINET, A CONCRETE PAD 36" (914.4 mm) x 60" (18,288 m) x 4" (101 mm) MIN. SIZE. THE COST OF LABOR AND MATERIALS ARE INCLUDED IN THE COST OF THE CONTROLLER.
- DOOR SHALL BE CONSTRUCTED FROM SAME TYPE OF MATERIAL AND THICKNESS AS CABINET.
- DOOR SHALL BE EQUIPPED WITH THREE POINT LATCHING MECHANISM WITH NYLON ROLLERS AT TOP THE BOTTOM.
- DOOR HINGE SHALL BE A HEAVY GAUGE CONTINUOUS HINGE WITH A 1/4" (6.35 mm) DIA. STAINLESS STEEL HINGE PIN.
- ALL EXTERNAL HARDWARE SHALL BE STAINLESS STEEL.
- CONTROL WIRING TO BE #12 AWG, 600V, TYPE "SIS" GRAY SWITCH BOARD WIRE, STRANDED COPPER.
- METER BOX SHALL BE MOUNTED ON THE SIDE OF CONTROL CABINET, NEAR TO THE SERVICE POLE.
- CABINETS SHALL BE PRIMED AND PAINTED AS SPECIFIED.
- THE HEADS OF CONNECTORS SCREWS SHALL BE PAINTED WHITE FOR NEUTRAL BAR CONNECTION AND GREEN FOR GROUND BAR CONNECTORS.
- ALL WIRING WITHIN THE CABINET SHALL BE COLOR CODED AS INDICATED.  
R = RED      BL = BLUE      W = WHITE  
B = BLACK      Y = YELLOW      G = GREEN
- PROVIDE SEALING GROMMETS FOR ALL OPEN WIRING EXTENDED FROM DEVICES IN BOXES OR CABINETS WITHIN THE CONTROL CABINET.
- ALL WIRING SHALL BE NEATLY DRESSED AND SUPPORTED.
- THE CONTROLLER SHALL BE CONSTRUCTED TO U.L. STD. 508 AND BEAR THE U.L. LABEL "ENCLOSED INDUSTRIAL CONTROL PANEL".
- 12" (304.8) X 16" (406.4 mm) STAINLESS STEEL EXTERIOR NAMEPLATE SHALL BE ENGRAVED TO "STATE OF ILLINOIS LIGHTING CONTROLS" UNLESS OTHERWISE SPECIFIED.

**FOR INFORMATION ONLY**

ASCERTAIN AND ASSURE CLEARANCE FROM UTILITY SECONDARY SPACE, AS APPLICABLE.

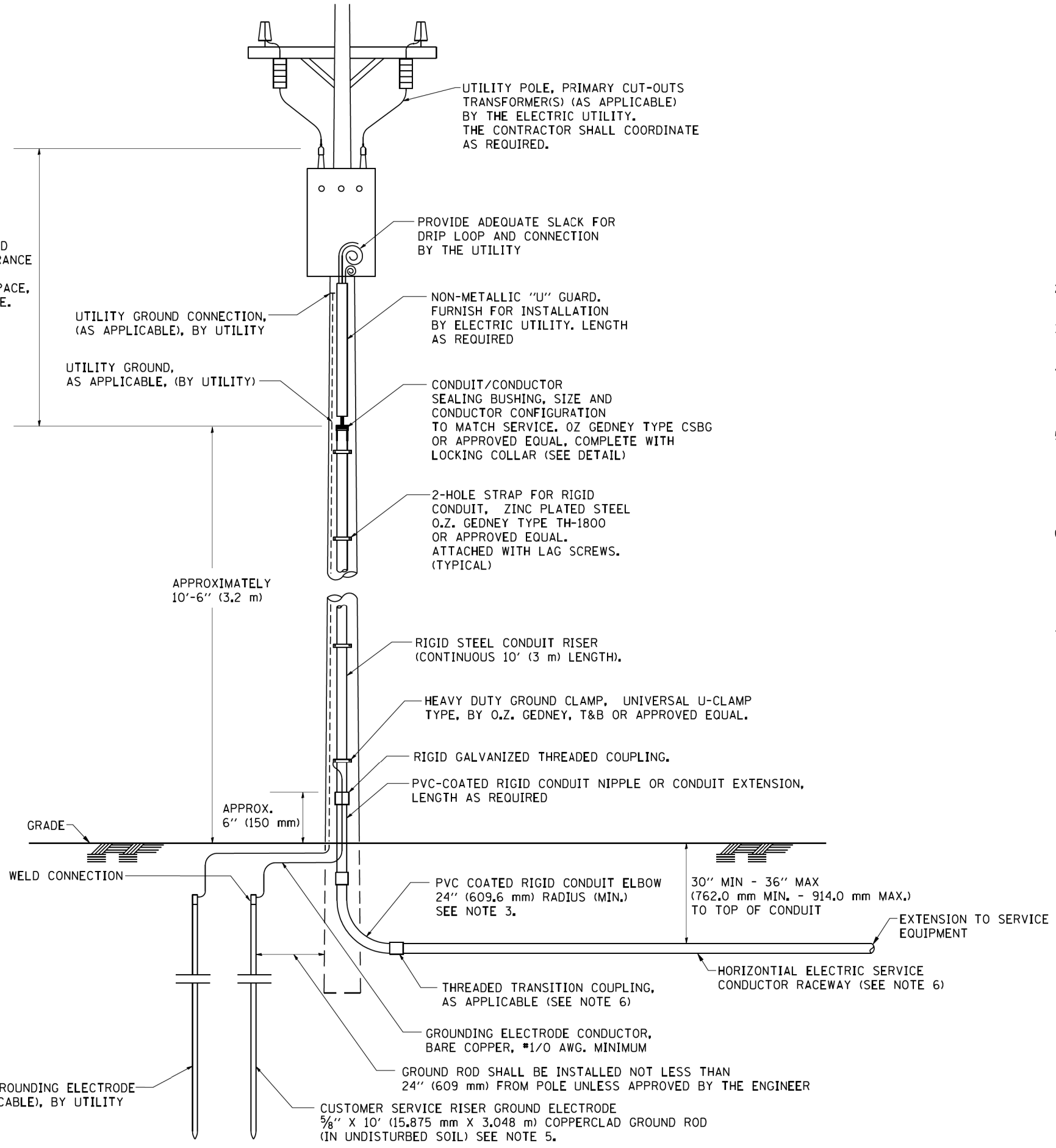

**APPLICATION**

THIS DETAIL APPLIES FOR LOW VOLTAGE ELECTRIC SERVICE (660 V OR LESS) FROM AN OVERHEAD UTILITY SUPPLY TO SEPERATLY-MOUNTED SERVICE EQUIPMENT.

**NOTES**

- SERVICE VOLTAGE SHALL BE AS INDICATED ELSEWHERE IN THE DRAWINGS.
- UNLESS OTHERWISE INDICATED, ITEMS AND WORK SHALL BE INCLUDED AND PAID AS PART OF THE ELECTRIC UTILITY SERVICE INSTALLATION PAY ITEM.
- CONDUIT AND CONNECTOR DIAMETER SHALL MATCH THE DIAMETER OF THE SERVICE CONDUCTOR RACEWAY AS INDICATED ON THE PLANS.
- PVC COATED RACEWAYS AND ACCESSORIES SHALL BE CAREFULLY INSTALLED WITH MFR RECOMMENDED TOOLS AND PROCEDURES TO AVOID DAMAGE. ANY DAMAGE SHALL BE REPAIRED WITH COMPATIBLE PVC TOUCH-UP MATERIAL TO THE SATISFACTION OF THE ENGINEER OR THE DAMAGED MATERIAL SHALL BE REPLACED AT NO ADDITIONAL COST.
- THE CONTRACTOR SHALL OBTAIN INSPECTION AND APPROVAL BY THE ENGINEER OF SERVICE RISER GROUND ELECTRODE, RISER ELBOW, NIPPLE AND CONNECTION TO SERVICE CONDUCTOR RACEWAY EXTENSION BEFORE BACKFILL AND SHALL ALSO OBTAIN INSPECTION OF SERVICE RISER AND SEALING BUSHING BEFORE UTILITY "U" GUARD INSTALLATION AND SERVICE CONNECTION.
- THE HORIZONTAL ELECTRIC SERVICE CONDUCTOR RACEWAY SHALL BE AS INDICATED AND SHALL BE MEASURED SEPARATELY FOR PAYMENT. WHEN THE RACEWAY IS PVC-COATED RIGID GALVANIZED STEEL, THE COUPLING SHALL BE THE SAME. WHEN THE RACEWAY IS PVC CONDUIT (IN CONCRETE), THE COUPLING SHALL BE A METALLIC TO NON METALLIC ADAPTER. WHEN THE RACEWAY IS ENCASED IN CONCRETE, THE CONCRETE SHALL EXTEND TO COVER THE COUPLING.
- PLANS AND DETAILS INDICATE THE GENERAL NATURE AND REQUIREMENTS. THEY DO NOT SHOW EVERY ACCESSORY AND ATTACHMENT, AND THEY DO NOT RELIEVE THE CONTRACTOR OF THE REQUIREMENTS OF THE SPECIFICATIONS AND SPECIAL PROVISIONS TO ASCERTAIN UTILITY REQUIREMENTS AND TO COORDINATE ACCORDINGLY, FURNISHING ALL ITEMS AND WORK NOT PROVIDED BY THE UTILITY, BUT NECESSARY FOR A COMPLETE SERVICE INSTALLATION IS REQUIRED AND SHALL BE INCLUDED IN THE ELECTRIC UTILITY SERVICE INSTALLATION PAY ITEM.

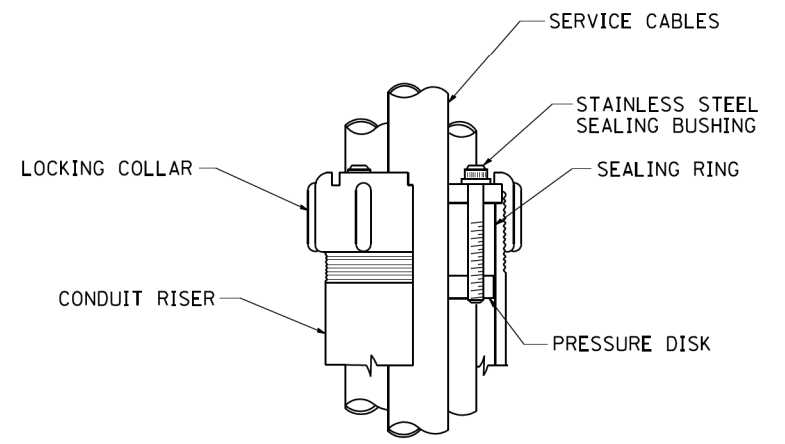

**SEALING BUSHING DETAIL**

|   |                             |               |                    |   |  |                         |             |               |        |                           |           |
|---|-----------------------------|---------------|--------------------|---|--|-------------------------|-------------|---------------|--------|---------------------------|-----------|
| FILE NAME =<br>W:\diststd\22x34\be228.dgn | USER NAME = gegl1enobt      | DESIGNED -    | REVISED - 03-03-06 | <b>STATE OF ILLINOIS<br/>DEPARTMENT OF TRANSPORTATION</b> | <b>ELECTRIC SERVICE INSTALLATION<br/>AERIAL, REMOTE DISCONNECT</b> |                         | F.A.P. RTE. | SECTION       | COUNTY | TOTAL SHEETS              | SHEET NO. |
|   | PLOT SCALE = 50.0000' / IN. | DRAWN -       | REVISED -          |   | SCALE: NONE  | SHEET NO. 1 OF 1 SHEETS | STA.        | 2013-038B-R   | COOK   | 821                       | 239       |
|   | PLOT DATE = 1/4/2008        | CHECKED - MEA | REVISED -          |   |  |                         | TO STA.     | <b>BE-220</b> |        | CONTRACT NO. <b>60J16</b> |           |
|   |                             | DATE -        | REVISED -          |   | FED. ROAD DIST. NO. 1 ILLINOIS FED. AID PROJECT                    |                         |             |               |        |                           |           |

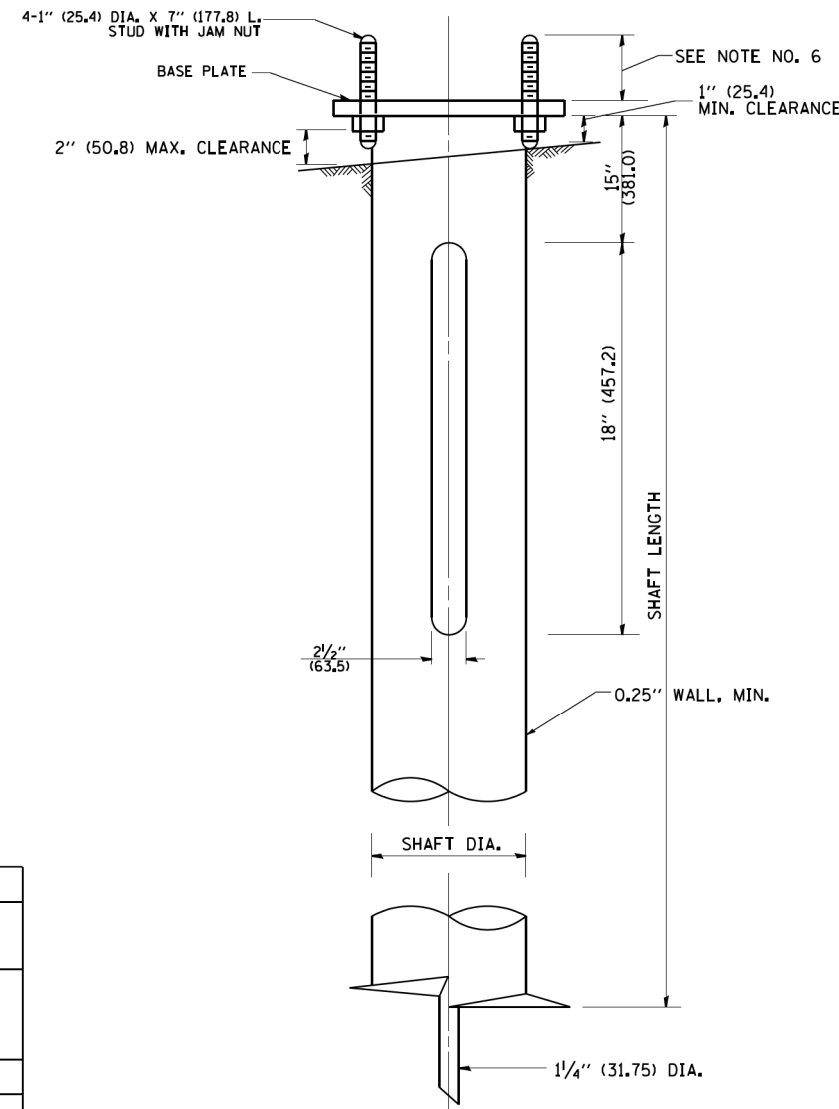
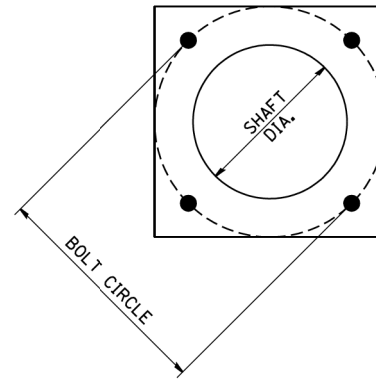

**HELIX FOUNDATION SIZE**

| POLE MOUNTING HEIGHT | BOLT CIRCLE | SHAFT DIAMETER | SHAFT LENGTH | BASEPLATE      |
|----------------------|-------------|----------------|--------------|----------------|
| 30 FT.               | 1 1/2"      | 8 5/8"         | 6 FT.        | 12"x12"x1"     |
| 31 FT.-35 FT.        | 1 1/2"      | 8 5/8"         | 6 FT.        | 12"x12"x1"     |
| 36 FT.-40 FT.        | 15"         | 8 5/8"         | 6 FT.        | 15"x15"x1 1/4" |
| 41 FT.-45 FT.        | 15"         | 8 5/8"         | 6 FT.        | 15"x15"x1 1/4" |
| 46 FT.-50 FT.        | 15"         | 10"            | 8 FT.        | 15"x15"x1 1/4" |

**METAL HELIX FOUNDATION MATERIALS**

| ITEM              | MATERIAL REQUIREMENT   |
|-------------------|--|
| BASEPLATE         | AASHTO M 270M, GRADE 36 (M270M, GRADE 250)                                 |
| SHAFT             | ASTM A 252, GRADE 2 (PHOSPHOROUS 0.04% MAXIMUM, SULFUR 0.05% MAXIMUM)      |
| HELIX SCREW       | AASHTO M 183 (ASTM A 635)  |
| PILOT POINT       | AASHTO M 270 (ASTM A 575)  |
| ANCHOR RODS/STUDS | AASHTO M 314 (ASTM F 1554)   |
| HEXAGON NUTS      | AASHTO M 291M (ASTM A 563) GRADE DH, OR AASHTO M 292 (ASTM A 194) GRADE 2H |
| WASHERS           | AASHTO M 293 (ASTM F 436)  |

**NOTES:**

- ALL DIMENSION IN INCHES (MILLIMETERS) UNLESS OTHERWISE SHOWN.
- ALL MATERIAL SHALL BE GALVINIZED ACCORDING TO AASHTO M111, UNLESS OTHERWISE SPECIFIED.
- ALL WELDS SHALL BE CONTINUOUS AND NOT LESS THAN 1/4" (6.35 mm) FILLET WELDS. THE WELDED FOUNDATION SHALL BE CAPABLE OF WITHSTANDING 10,000 FT/LBS (13558.18 n.m) OF INSTALLATION TORQUE APPLIED ABOUT THE AXIS OF THE FOUNDATION.
- THE HELIX FOUNDATION SHAFT SHALL BE INSTALLED VERTICAL AND THE BASE PLATE SHALL BE IN LEVEL. THE BREAKAWAY COUPLINGS AND HARDWARE SHALL NOT BE USED TO ALIGN THE POLE INSTALLATION.
- THE CABLE TRENCH SHALL BE BACKFILLED AND FIRMLY COMPACTED BEFORE THE INSTALLATION OF THE LIGHT POLE.
- THE CONTRACTOR SHALL COORDINATE EXTENSION OF ANCHOR BOLTS ABOVE TOP OF THE BASE PLATE WITH THE BREAKAWAY DEVICE MANUFACTURER'S REQUIREMENTS.
- ANY VOIDS WITHIN THE METAL FOUNDATION SHALL BE FILLED WITH FINE AGGREGATE.
- METAL FOUNDATIONS SHALL BE INSTALLED IN UNDISTURBED SOIL. PREDRILLING A PILOT HOLE AND/OR BACKFILLING AROUND THE FOUNDATION IS NOT ALLOWED.
- THE METAL FOUNDATION SHALL NOT BE INSTALLED TO A TORQUE WHICH EXCEEDS THE MANUFACTURER'S MAXIMUM TORQUE RATING NOR SHALL IT BE INSTALLED TO AN INSTALLATION TORQUE VALUE OF LESS THAN 3,500 FT LB (4,750 KNM). METAL FOUNDATIONS THAT ARE NOT INSTALLED TO FULL INSTALLATION DEPTH OR DO NOT ACHIEVE THE MINIMUM INSTALLATION TORQUE SHALL BE REMOVED AND REPLACED WITH A CONCRETE FOUNDATION AT NO ADDITIONAL COST.
- THE BASEPLATE SHALL BE PERPENDICULAR TO THE SHAFT AXIS ( $\pm 1^\circ$ ) AND THE HOLE CENTERLINE SHALL BE CONCENTRIC ( $\pm 0.188$ ) TO THE SHAFT AXIS.
- THE PILOT POINT AND SHAFT AXIS SHALL BE CONCENTRIC ( $\pm 0.125$ ) AND IN LINE ( $\pm 2^\circ$ ).
- THE BASEPLATE SHALL BE STAMPED WITH THE MANUFACTURERS NAME AND DATE OF MANUFACTURE.
- GRADING AROUND LIGHT POLE FOUNDATIONS SHALL MEET THE REQUIREMENTS OF ARTICLE 836.03 OF THE STANDARD SPECIFICATIONS.

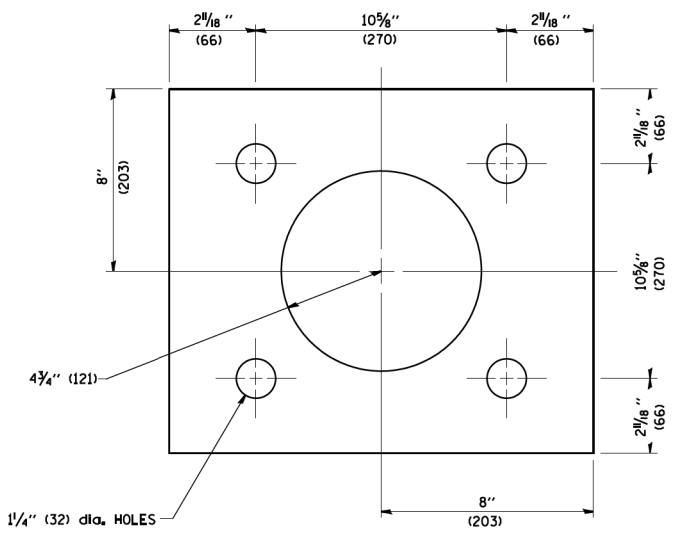
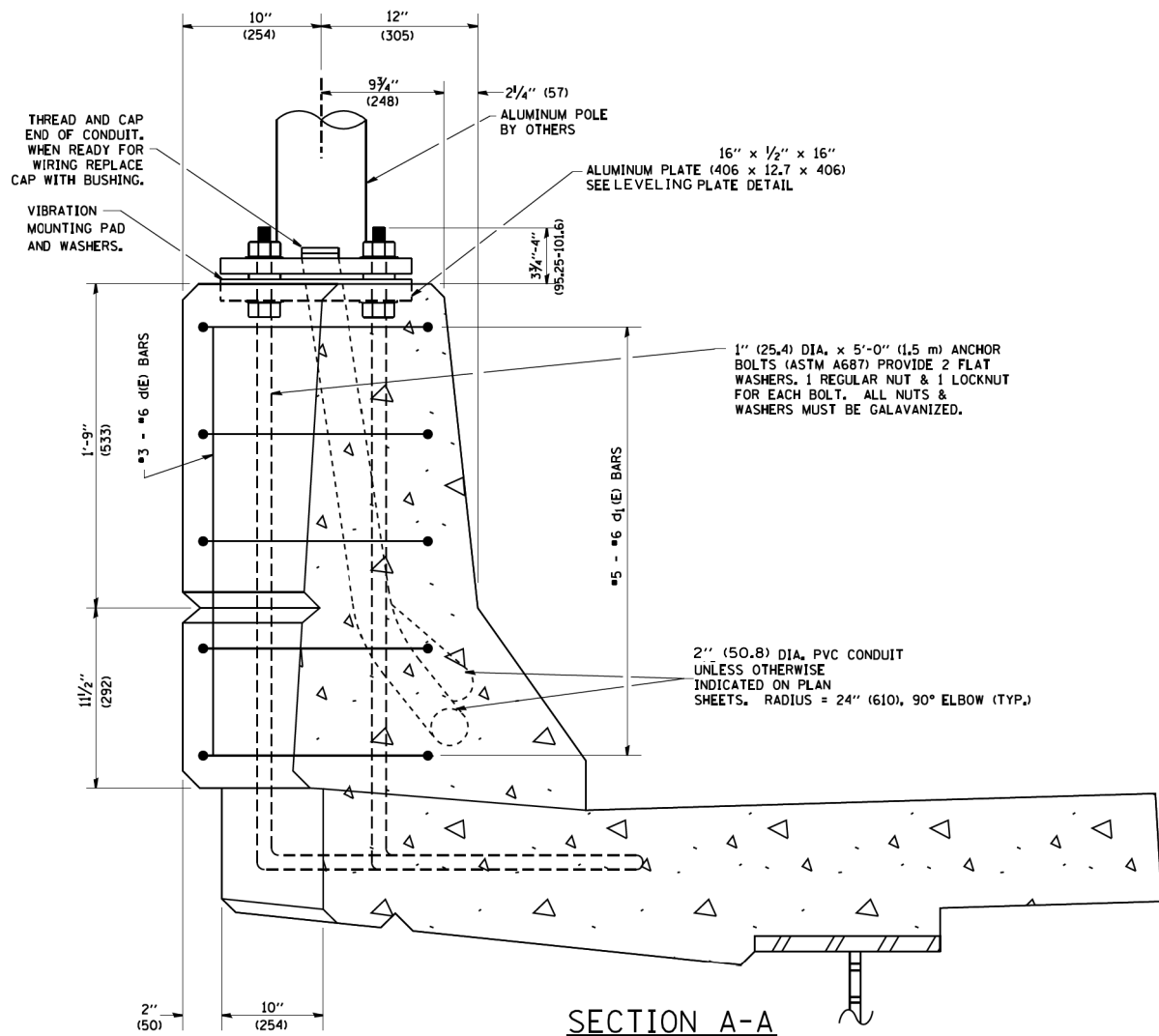
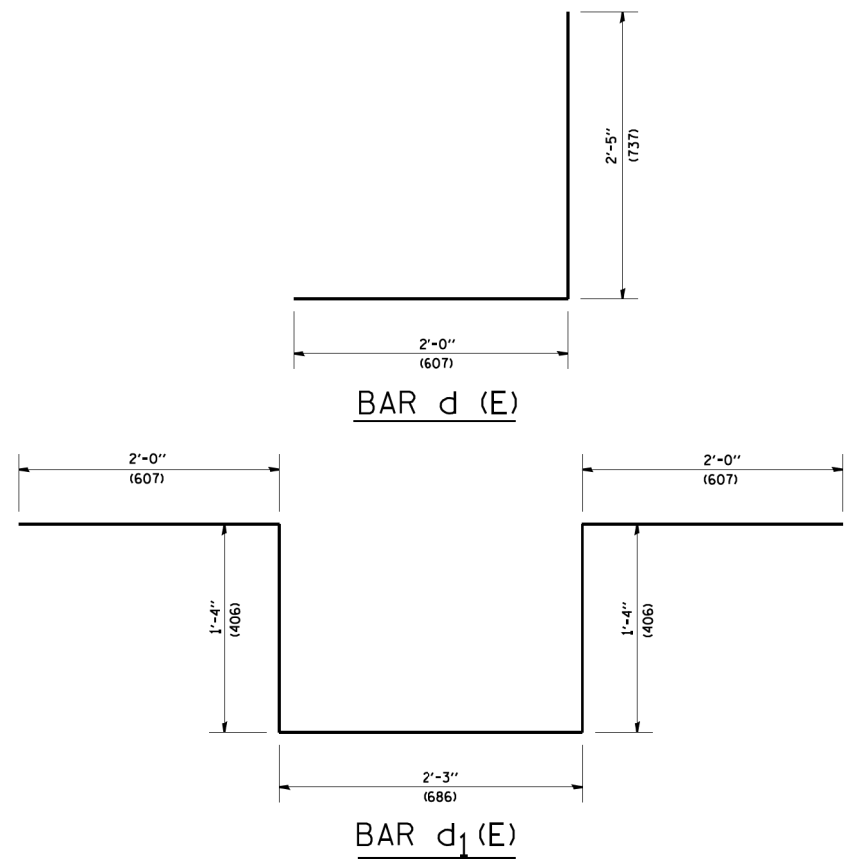

- NOTES**
1. ALL DIMENSIONS ARE IN INCHES (MILLIMETERS) UNLESS OTHERWISE SHOWN.
  2. LEVEL LIGHT POLE PLATES, USING THE FLANGE NUTS, PRIOR TO POURING THE PARAPET WALL. THE TOP OF THE PLATE SHALL BE AT THE SAME ELEVATION AS THE FINISHED CONCRETE PARAPET.
  3. THE COST OF ANCHOR BOLTS, LEVELING PLATE AND FOUNDATION IS INCLUDED IN THE COST OF THE BRIDGE STRUCTURE.

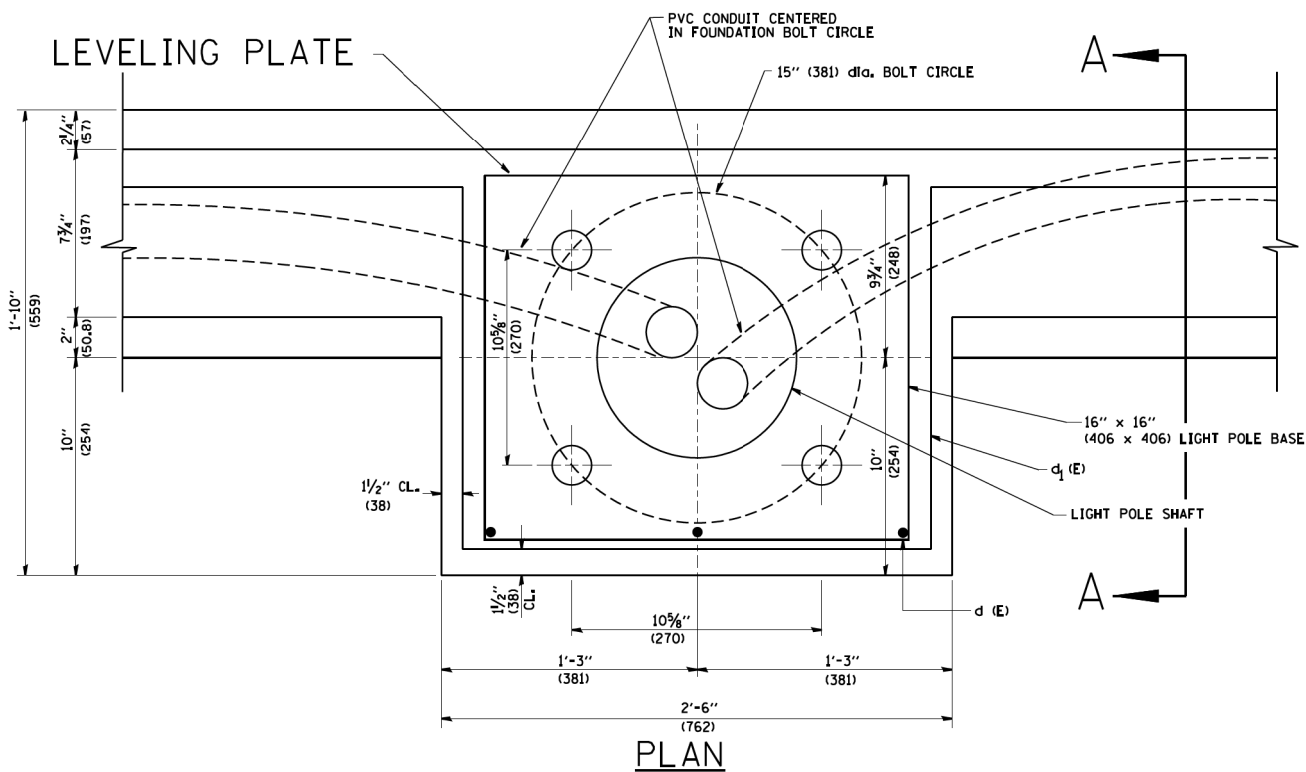
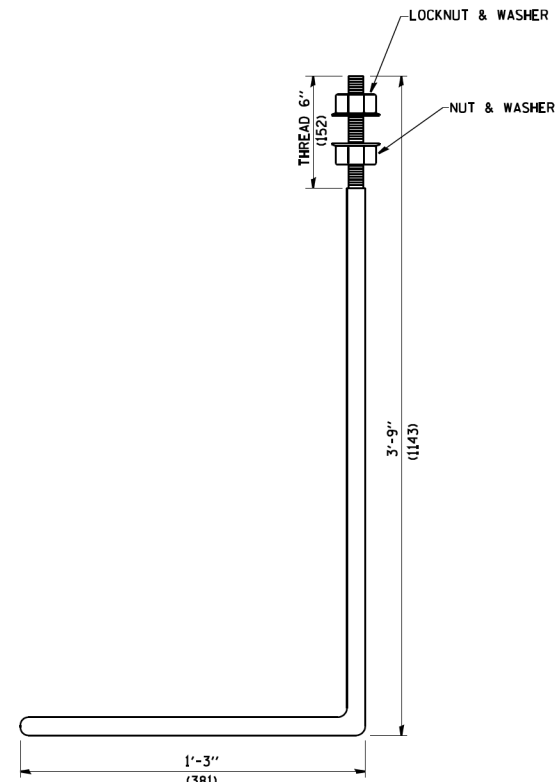

|   |                             |                       |                    |   |   |                         |      |                |                        |                |                        |                     |
|---|-----------------------------|-----------------------|--------------------|---|---|-------------------------|------|----------------|------------------------|----------------|------------------------|---------------------|
| FILE NAME =<br>W:\diststd\22x34\be338.dgn | USER NAME = gegl1enobt      | DESIGNED -<br>DRAWN - | REVISED - 04-22-02 | <b>STATE OF ILLINOIS<br/>DEPARTMENT OF TRANSPORTATION</b> | <b>LIGHT POLE MOUNTED ON CONCRETE PARAPET WALL<br/>15" (381 mm) BOLT CIRCLE</b> |                         |      | F.A.P.<br>RTE. | SECTION<br>2013-038B-R | COUNTY<br>COOK | TOTAL<br>SHEETS<br>821 | SHEET<br>NO.<br>241 |
|   | PLOT SCALE = 50.0000' / IN. | CHECKED -             | REVISED -          |   | SCALE: NONE   | SHEET NO. 1 OF 1 SHEETS | STA. | TO STA.        | <b>BE-330</b>          |                | CONTRACT NO. 60J16     |                     |
|   | PLOT DATE = 1/4/2008        | DATE -                | REVISED -          |   | FED. ROAD DIST. NO. 1 ILLINOIS FED. AID PROJECT                                 |                         |      |                |                        |                |                        |                     |
| • 372/373/IL 171 (SB)                     |                             |                       |                    |   |   |                         |      |                |                        |                |                        |                     |

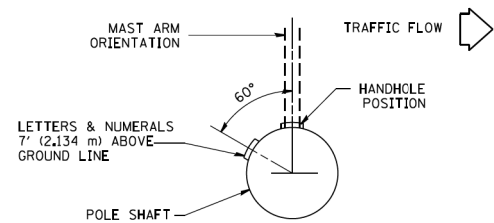

POSITION OF HANDHOLE AND POLE NUMBER FOR SINGLE MAST ARM POLES MOUNTED ON BRIDGE PARAPET OR BARRIER WALL

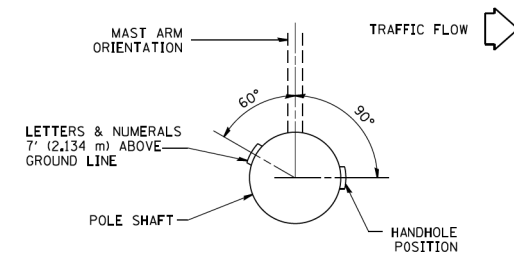

POSITION OF HANDHOLE AND POLE NUMBER FOR SINGLE MAST ARM POLES

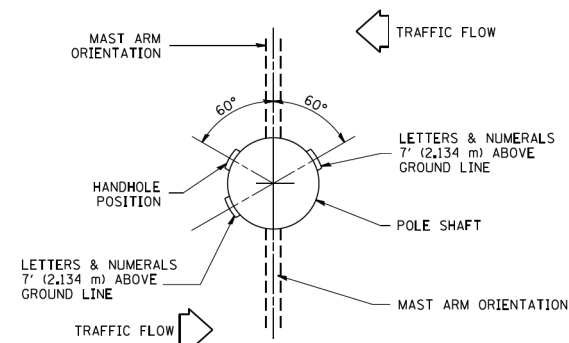

POSITION OF HANDHOLE AND POLE NUMBER FOR TWIN MAST ARM POLES

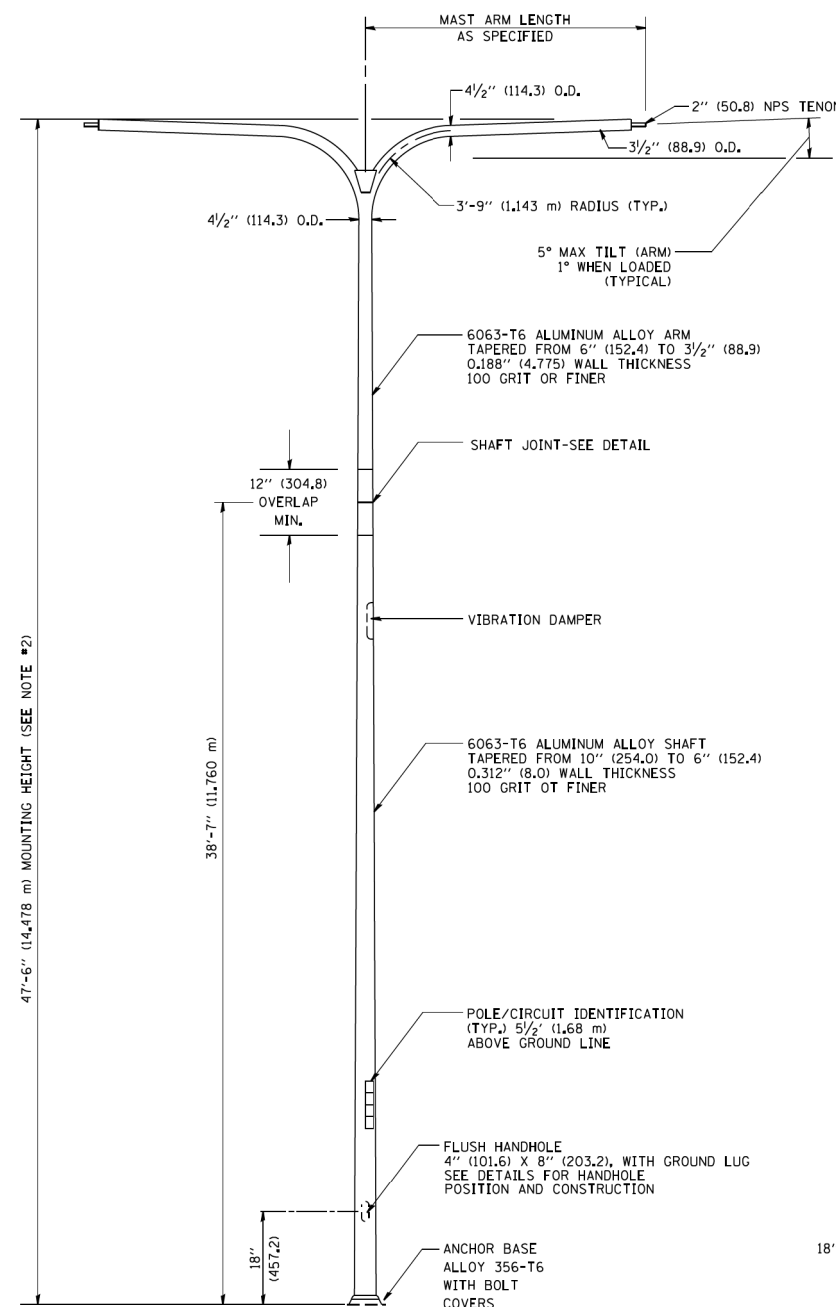

TWIN ARM POLE

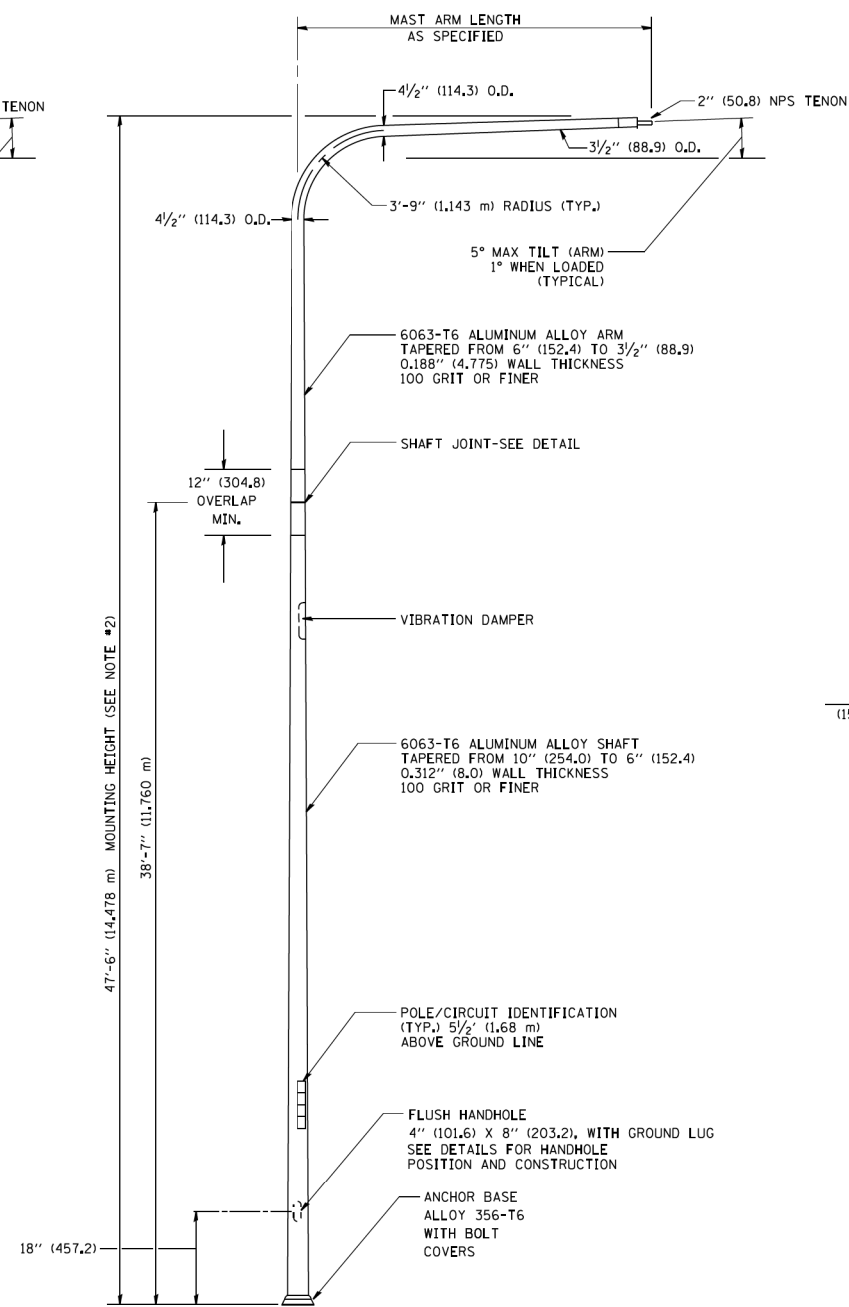

SINGLE ARM POLE

- NOTES:
- ALL DIMENSIONS ARE IN INCHES (MILLIMETERS) UNLESS OTHERWISE SHOWN.
  - MOUNTING HEIGHT IS DEFINED AS THE DISTANCE FROM THE CENTERLINE OF THE TENON TO THE BOTTOM OF THE ANCHOR BASE.
  - TWO PIECE SHAFT WILL BE MATCHED MARKED AND INTERCHANGEABLE BETWEEN DIFFERENT UNITS. FIELD DRILLING OF THE HOLES WILL NOT BE ALLOWED.
  - THE LIGHT POLE WILL MEET AASHTO DESIGN CRITERIA AS SPECIFIED.
  - THE INSTALLING CONTRACTOR WILL PROVIDE A UL LISTED GROUNDING CONNECTOR, BURNDY K2C23, T&B SP4DL OR APPROVED EQUAL.
  - LIGHT POLES WILL NOT BE INSTALLED WITHOUT MAST ARMS AND LUMINAIRES.
  - LIGHT POLES WILL BE SET PLUMB ON THE FOUNDATION WITHOUT THE USE OF LEVELING NUTS, WASHERS OR SHIMS.
  - LIGHTING UNIT IDENTIFICATION NUMBERS SHALL BE INSTALLED BEFORE THE LIGHTING UNIT IS ENERGIZED.

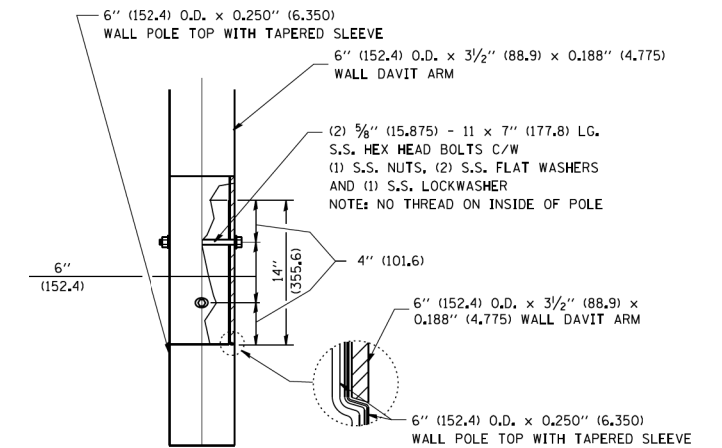

DAVIT ARM CONNECTION  
[14" (355.6) OVERLAP SHOWN]

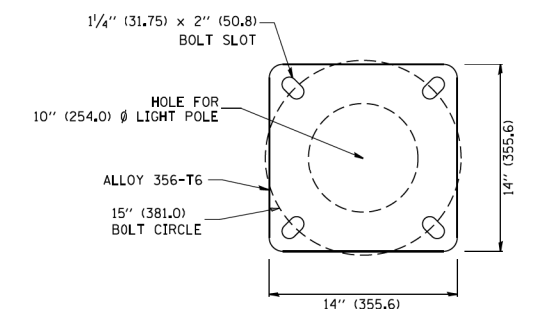

LIGHT POLE BASE PLATE DETAIL  
(FOR POLE MOUNTED ON 15 INCH (381.0) BOLT CIRCLE FOUNDATION)

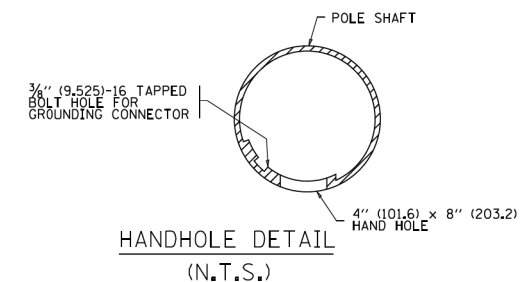

HANDHOLE DETAIL  
(N.T.S.)

|   |                             |             |                               |
|---|-----------------------------|-------------|-------------------------------|
| FILE NAME =                             | USER NAME = leyse           | DESIGNED -  | REVISED - D. DREW 05-07-92    |
| ca:\pwork\pwork\leyse\0108315\be410.dgn |                             | DRAWN - LEY | REVISED - R. TOMSONS 09-06-00 |
|   | PLOT SCALE = 50.0000' / in. | CHECKED -   | REVISED - R. TOMSONS 09-02-03 |
|   | PLOT DATE = 4/4/2013        | DATE -      | REVISED - R. TOMSONS 01-18-13 |

STATE OF ILLINOIS  
DEPARTMENT OF TRANSPORTATION

|                                   |                         |      |         |
|-----------------------------------|-------------------------|------|---------|
| DAVIT LIGHT POLE                  |                         |      |         |
| 47'-6" (14.478 m) MOUNTING HEIGHT |                         |      |         |
| SCALE: NONE                       | SHEET NO. 1 OF 1 SHEETS | STA. | TO STA. |

|   |             |                    |              |           |
|---|-------------|--------------------|--------------|-----------|
| F.A.P. RTE.                                     | SECTION     | COUNTY             | TOTAL SHEETS | SHEET NO. |
|   | 2013-038B-R | COOK               | 821          | 242       |
| BE-410  |             | CONTRACT NO. 60J16 |              |           |
| FED. ROAD DIST. NO. 1 ILLINOIS FED. AID PROJECT |             |                    |              |           |

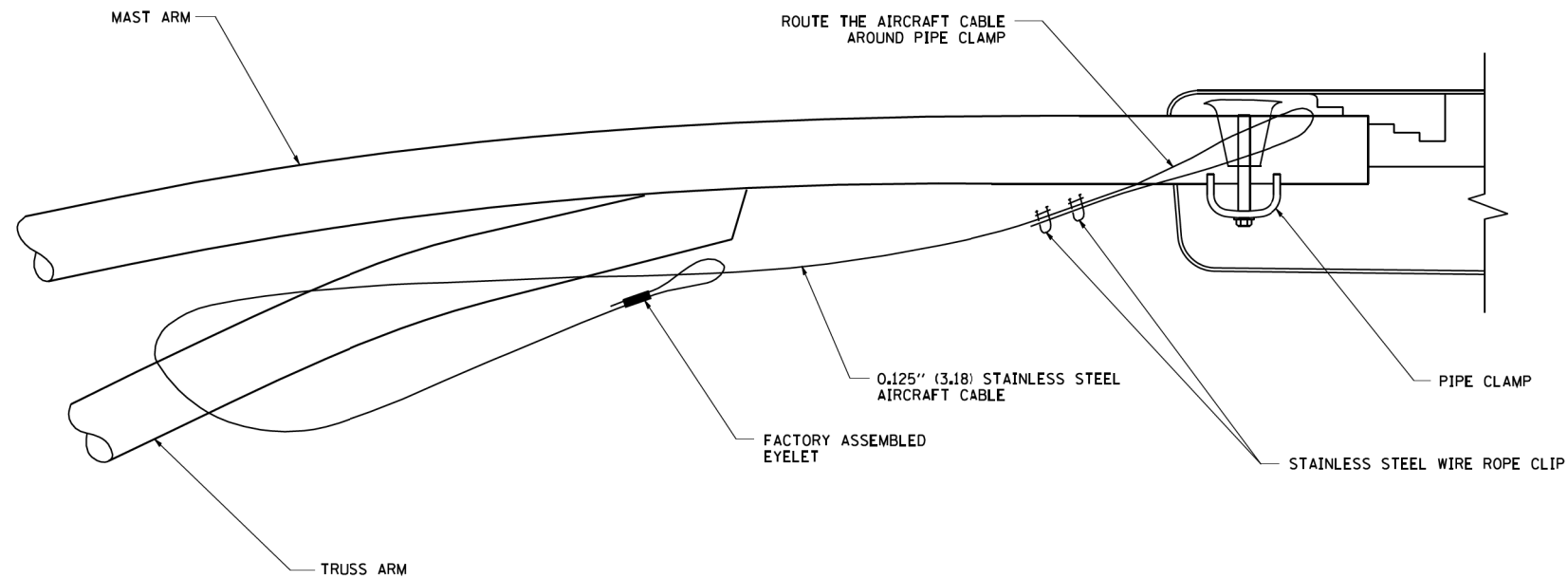

**SIDE VIEW (TRUSS ARM)**  
N.T.S.

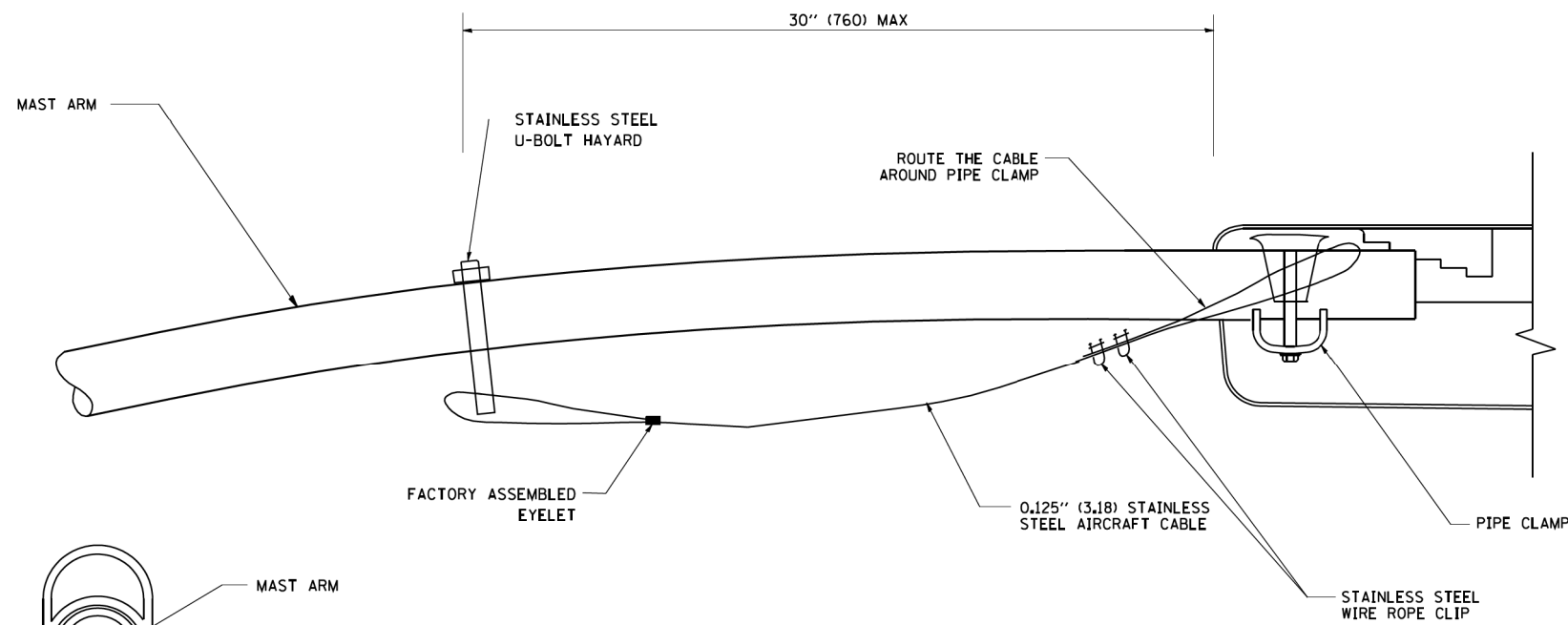

**SIDE VIEW (SINGLE MEMBER OR DAVIT ARM)**  
N.T.S.

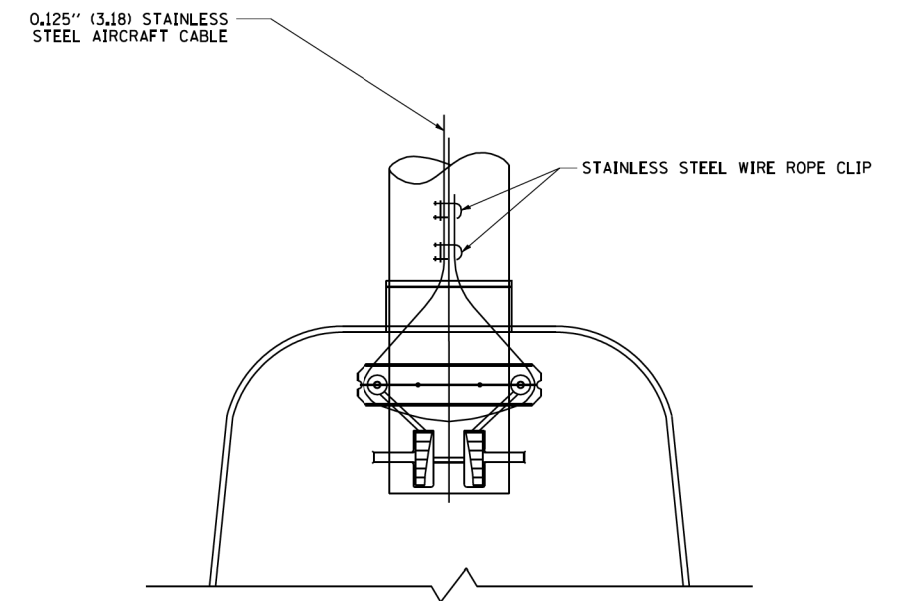
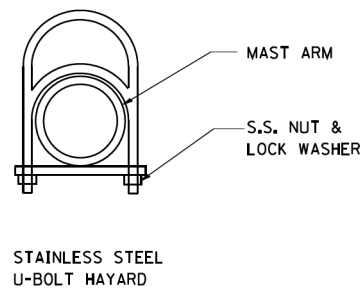

**BOTTOM VIEW**  
N.T.S.

**NOTES:**

1. ALL DIMENSIONS ARE IN MILLIMETERS (INCHES) UNLESS OTHERWISE SHOWN.
2. CONTRACTOR SHALL ADJUST THE WIRE CLIP TO ELIMINATE ANY SLACK FROM THE WIRE ROPE.
3. THE 0.125" (3.18) STAINLESS STEEL AIRCRAFT CABLE SHALL REMAIN VISIBLE FROM THE GROUND LEVEL.
4. THE BREAKING STRENGTH OF THE CABLE SHALL BE 1700 LBS. MIN.

|   |   |                       |   |   |  |                         |      |                |             |                           |                 |              |
|---|---|-----------------------|---|---|--|-------------------------|------|----------------|-------------|---------------------------|-----------------|--------------|
| FILE NAME =<br>W:\diststd\22x34\be701.dgn       | USER NAME = gegl1enobt                              | DESIGNED -<br>DRAWN - | REVISED - 08-08-03<br>REVISED -<br>REVISED -<br>REVISED - | <b>STATE OF ILLINOIS<br/>DEPARTMENT OF TRANSPORTATION</b> | <b>LUMINAIRE SAFETY CABLE ASSEMBLY</b> |                         |      | F.A.P.<br>RTE. | SECTION     | COUNTY                    | TOTAL<br>SHEETS | SHEET<br>NO. |
|   | PLOT SCALE = 50.000 ' / IN.<br>PLOT DATE = 1/4/2008 | CHECKED -<br>DATE -   |   |   | SCALE: NONE                            | SHEET NO. 1 OF 1 SHEETS | STA. | TO STA.        | 2013-038B-R | COOK                      | 821             | 243          |
|   |   |                       |   |   |  |                         |      | <b>BE-701</b>  |             | <b>CONTRACT NO. 60J16</b> |                 |              |
| FED. ROAD DIST. NO. 1 ILLINOIS FED. AID PROJECT |   |                       |   |   |  |                         |      |                |             |                           |                 |              |

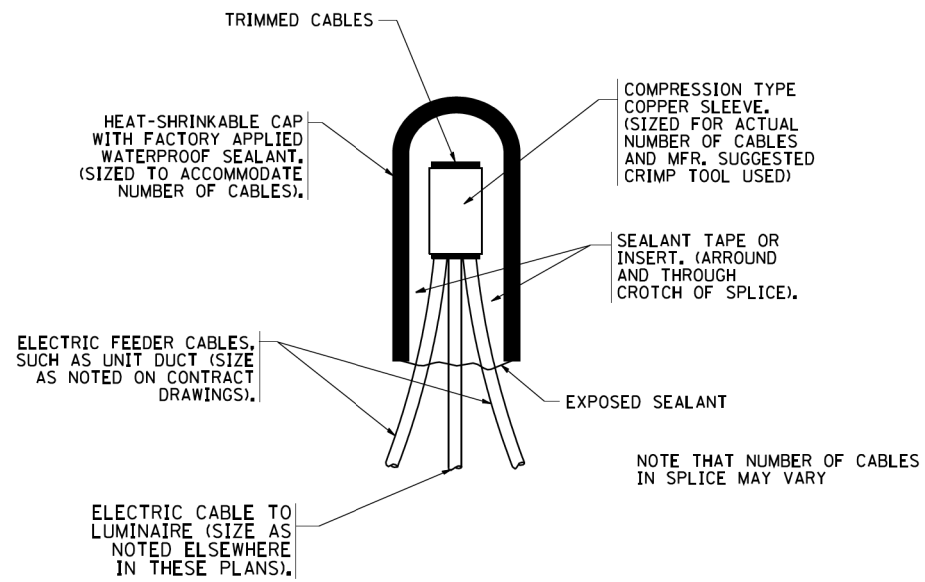

**TYPICAL SPLICE DETAIL**

N.T.S.

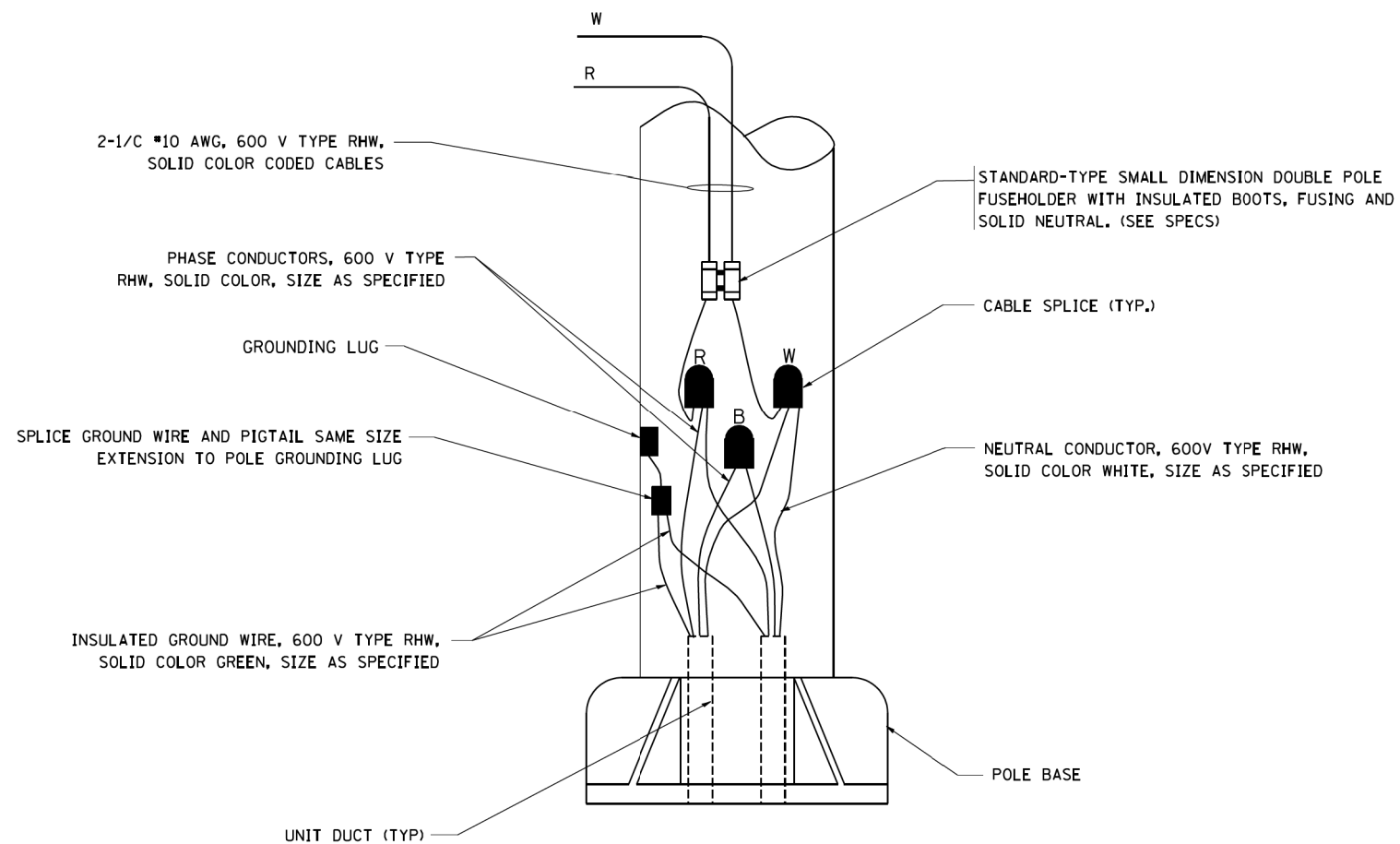

**POLE WIRING DETAIL**

N.T.S.

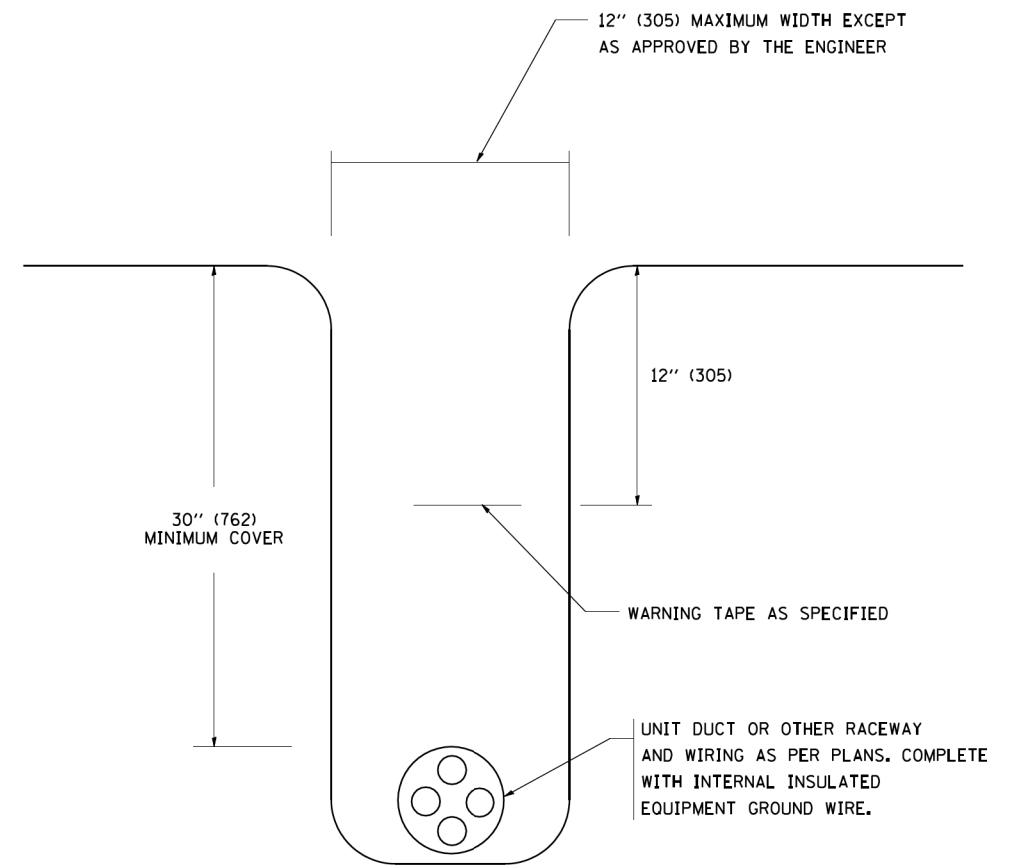

**TYPICAL WIRING IN TRENCH DETAIL**

N.T.S.

|   |                             |            |                    |   |   |                         |      |                |   |        |                 |              |                    |
|---|-----------------------------|------------|--------------------|---|---|-------------------------|------|----------------|---|--------|-----------------|--------------|--------------------|
| FILE NAME =<br>W:\diststd\22x34\be702.dgn | USER NAME = gegl1enobt      | DESIGNED - | REVISED - 08-08-03 | <b>STATE OF ILLINOIS<br/>DEPARTMENT OF TRANSPORTATION</b> | <b>MISC. ELECTRICAL DETAILS<br/>SHEET A</b> |                         |      | F.A.P.<br>RTE. | SECTION   | COUNTY | TOTAL<br>SHEETS | SHEET<br>NO. |                    |
|   | PLOT SCALE = 50.000 ' / IN. | DRAWN -    | REVISED -          |   | SCALE: NONE                                 | SHEET NO. 1 OF 1 SHEETS | STA. | TO STA.        | 2013-038B-R                                     | COOK   | 821             | 244          |                    |
|   | PLOT DATE = 1/4/2008        | CHECKED -  | REVISED -          |   |   |                         |      |                | BE-702  |        |                 |              |                    |
|   |                             | DATE -     | REVISED -          |   |   |                         |      |                | FED. ROAD DIST. NO. 1 ILLINOIS FED. AID PROJECT |        |                 |              | CONTRACT NO. 60J16 |



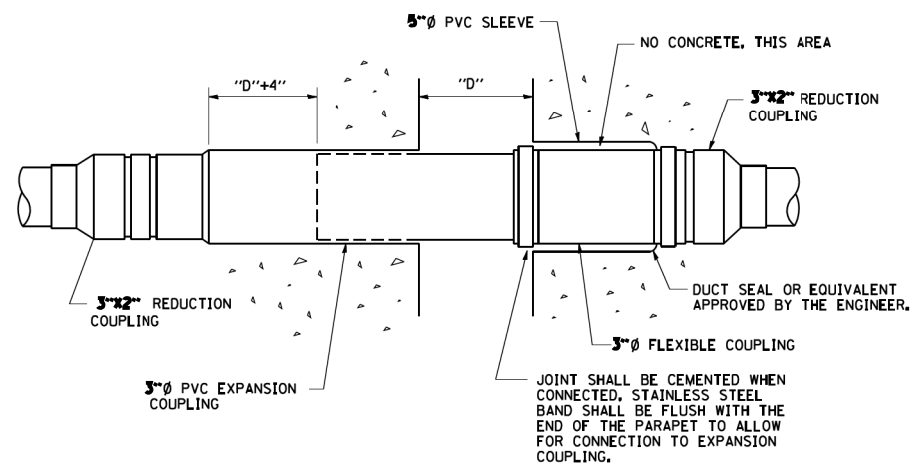

**INSTALLATION OF CONDUIT  
 IN BRIDGE PARAPET EXPANSION JOINT  
 (N.T.S.)**

|                          |                             |                   |           |  |   |                         |      |                |   |                           |                 |              |
|--------------------------|-----------------------------|-------------------|-----------|--|---|-------------------------|------|----------------|---|---------------------------|-----------------|--------------|
| FILE NAME =<br>be703.dgn | USER NAME = gegl1enobt      | DESIGNED -        | REVISED - | <b>STATE OF ILLINOIS<br/>         DEPARTMENT OF TRANSPORTATION</b> | <b>MISCELLANEOUS ELECTRICAL DETAILS, SHEET B<br/>         J BOX EMBEDDED IN BARRIER WALL - INSTALLATION OF CONDUIT IN BRIDGE<br/>         PARAPET EXPANSION JOINT - ELECTRIC CONNECTION TO UNDERPASS LIGHTING</b> |                         |      | F.A.P.<br>RTE. | SECTION   | COUNTY                    | TOTAL<br>SHEETS | SHEET<br>NO. |
|                          | PLOT SCALE = 50.0000' / IN. | DRAWN -           | REVISED - |  | SCALE: NONE   | SHEET NO. 1 OF 1 SHEETS | STA. | TO STA.        | 2013-038B-R                                     | COOK                      | 821             | 245          |
|                          | PLOT DATE = 2/5/2009        | CHECKED -         | REVISED - |  |   |                         |      |                | <b>BE-703</b>                                   | CONTRACT NO. <b>60J16</b> |                 |              |
|                          |                             | DATE - 01-20-2009 | REVISED - |  |   |                         |      |                | FED. ROAD DIST. NO. 1 ILLINOIS FED. AID PROJECT |                           |                 |              |

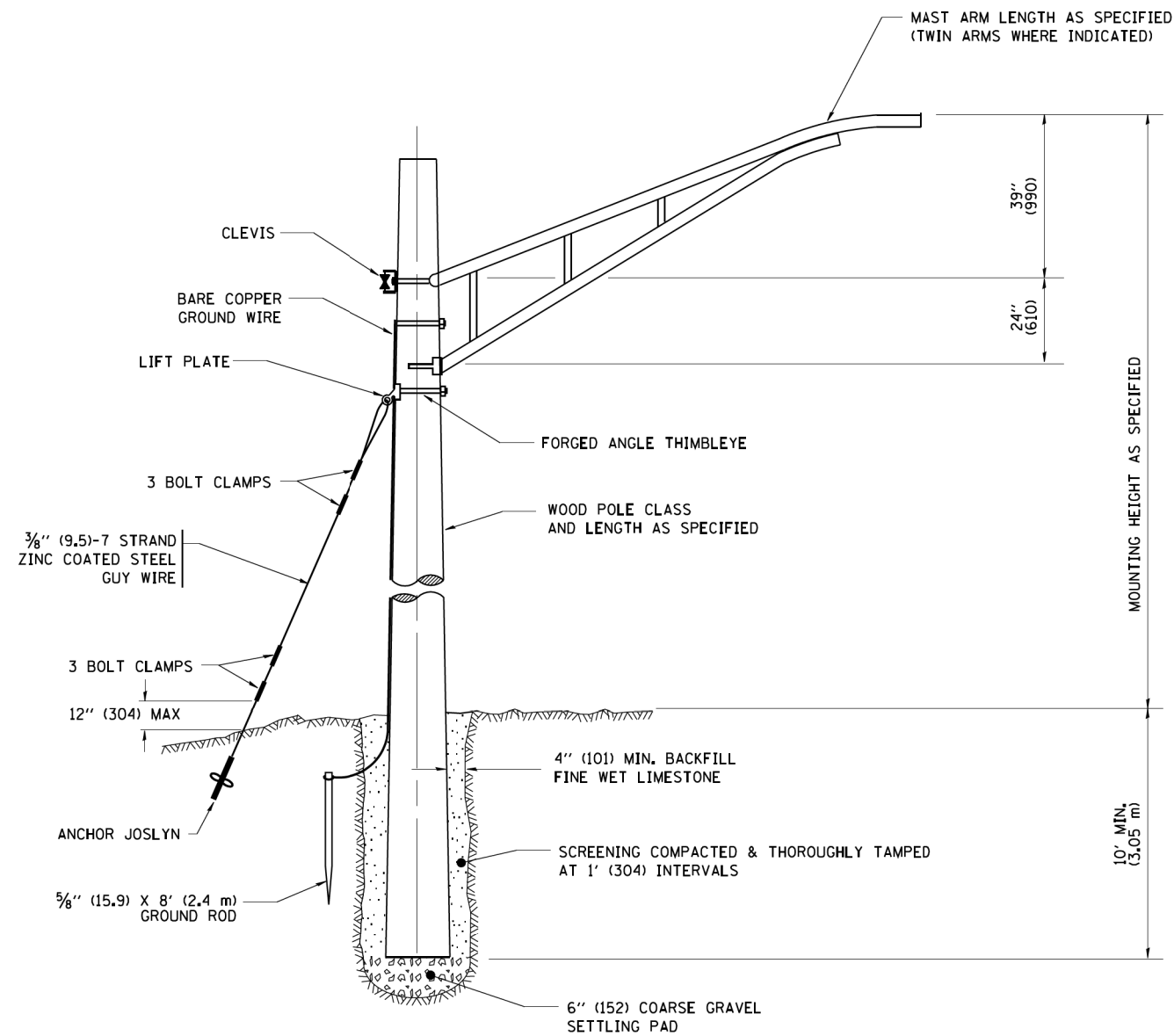

TEMPORARY LIGHT POLE DETAIL

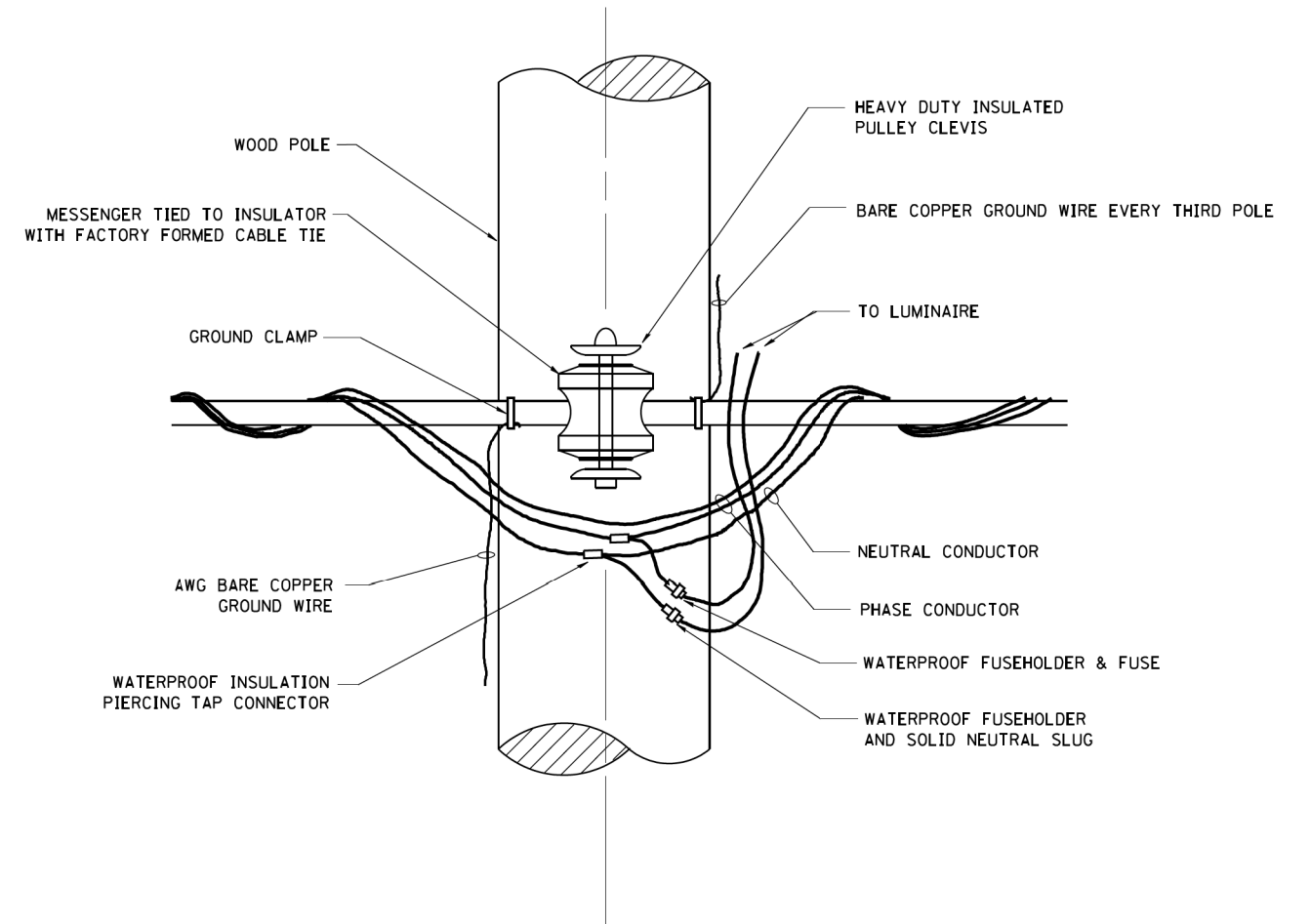

TEMPORARY LIGHT POLE ATTACHMENT DETAIL

**NOTES:**

1. ALL DIMENSIONS IN INCHES (MILLIMETERS) UNLESS OTHERWISE INDICATED

|   |                             |                       |                                 |   |                                     |                         |      |   |               |                           |                 |              |
|---|-----------------------------|-----------------------|---------------------------------|---|-------------------------------------|-------------------------|------|---|---------------|---------------------------|-----------------|--------------|
| FILE NAME =<br>W:\diststd\22x34\be800.dgn | USER NAME = gegl1enobt      | DESIGNED -<br>DRAWN - | REVISED - 08-08-03<br>REVISED - | <b>STATE OF ILLINOIS<br/>DEPARTMENT OF TRANSPORTATION</b> | <b>TEMPORARY LIGHT POLE DETAILS</b> |                         |      | F.A.P.<br>RTE.                                  | SECTION       | COUNTY                    | TOTAL<br>SHEETS | SHEET<br>NO. |
|   | PLOT SCALE = 50.000 ' / IN. | CHECKED -             | REVISED -                       |   | SCALE: NONE                         | SHEET NO. 1 OF 1 SHEETS | STA. | TO STA.   | 2013-038B-R   | COOK                      | 821             | 246          |
|   | PLOT DATE = 1/4/2008        | DATE -                | REVISED -                       |   |                                     |                         |      |   | <b>BE-800</b> | CONTRACT NO. <b>60J16</b> |                 |              |
|   |                             |                       |                                 |   |                                     |                         |      | FED. ROAD DIST. NO. 1 ILLINOIS FED. AID PROJECT |               |                           |                 |              |

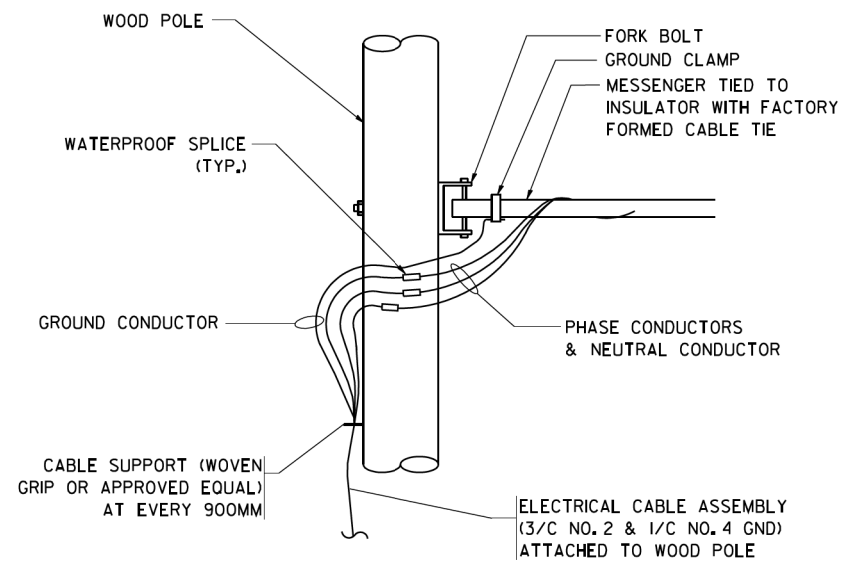

**AERIAL CABLE CONNECTION DETAIL**  
N.T.S.

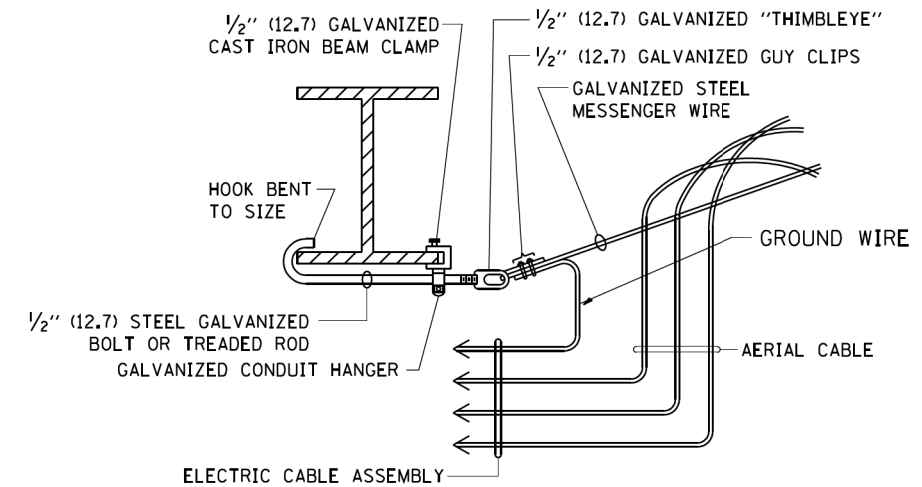

**AERIAL CABLE ATTACHED TO STRUCTURE**  
NOT TO SCALE

**NOTES:**

1. ALL DIMENSIONS IN INCHES (MILLIMETERS) UNLESS OTHERWISE INDICATED.
2. SEE PROPOSED LIGHTING PLAN FOR CONDUIT, CABLE AND ROUTING.
3. THE CONTRACTOR SHALL PROVIDE INTERMEDIATE SUPPORTS TO MAINTAIN MINIMUM CLEARANCES. REFER TO AERIAL CABLE ATTACHED TO STRUCTURE DETAIL.
4. COST OF SPLICES AND MOUNTING HARDWARE SHALL BE INCLUDED IN THE UNIT PRICE FOR AERIAL CABLE.

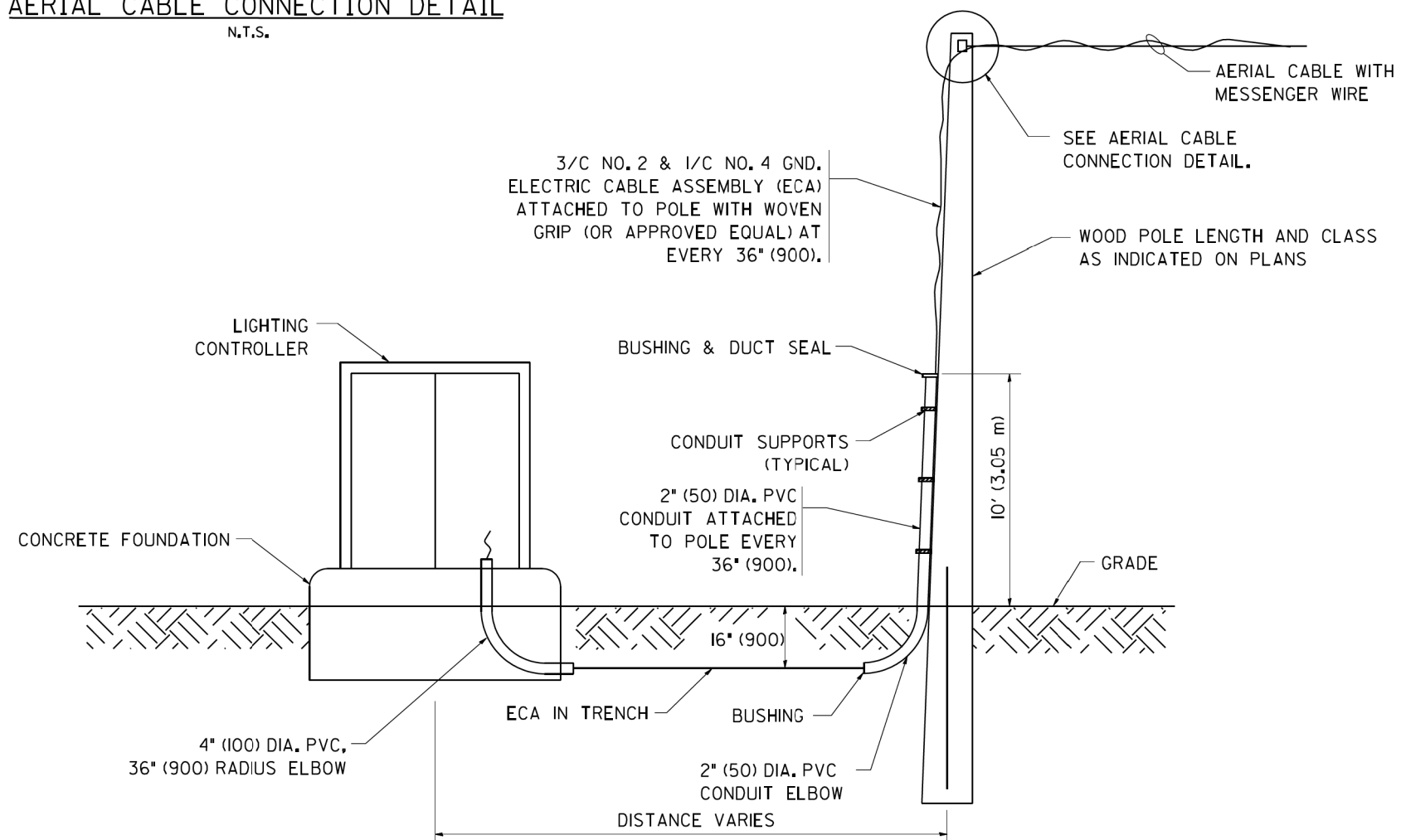

**WOOD POLE TO LIGHTING CONTROLLER WIRING CONNECTION DETAIL**  
N.T.S.

|  |                        |   |   |   |  |      |     |                |         |                           |                 |              |
|--|------------------------|---|---|---|--|------|-----|----------------|---------|---------------------------|-----------------|--------------|
| FILE NAME =<br>W:\diststd\22x34\be801.dgn          | USER NAME = gegl1enobt | DESIGNED -<br>DRAWN -                                     | REVISED - 08-08-03<br>REVISED -<br>REVISED -<br>REVISED - | <b>STATE OF ILLINOIS<br/>DEPARTMENT OF TRANSPORTATION</b> | <b>TEMPORARY AERIAL CABLE INSTALLATION</b> |      |     | F.A.P.<br>RTE. | SECTION | COUNTY                    | TOTAL<br>SHEETS | SHEET<br>NO. |
| PLOT SCALE = 50.000' / IN.<br>PLOT DATE = 1/4/2008 | CHECKED -<br>DATE -    | SCALE: NONE    SHEET NO. 1 OF 1 SHEETS    STA.    TO STA. |   |   | 2013-038B-R                                | COOK | 821 | 247            |         |                           |                 |              |
|  |                        |   |   |   |  |      |     | <b>BE-801</b>  |         | CONTRACT NO. <b>60J16</b> |                 |              |
| FED. ROAD DIST. NO. 1 ILLINOIS FED. AID PROJECT    |                        |   |   |   |  |      |     |                |         |                           |                 |              |

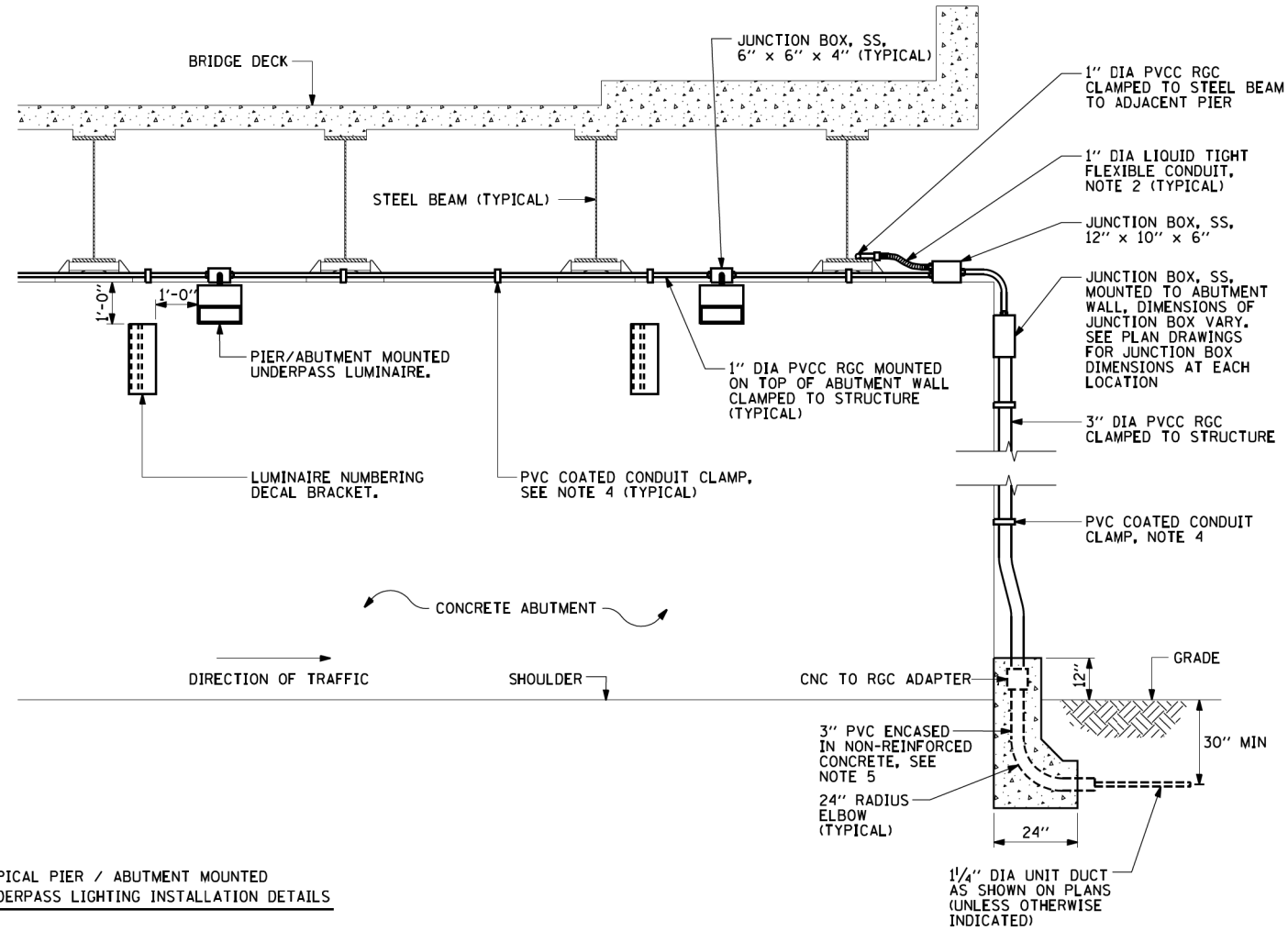
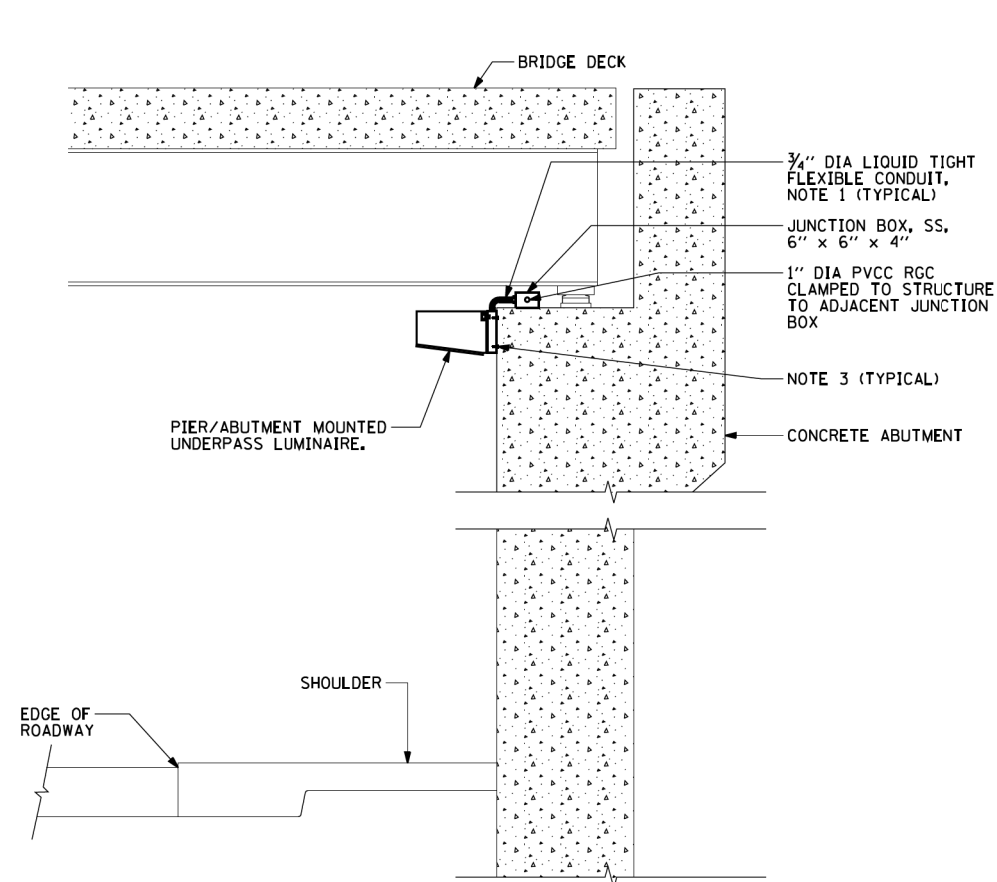

TYPICAL PIER / ABUTMENT MOUNTED UNDERPASS LIGHTING INSTALLATION DETAILS

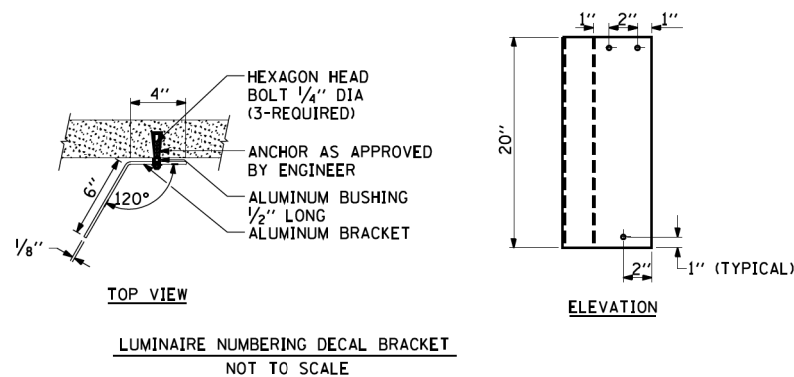

LUMINAIRE NUMBERING DECAL BRACKET NOT TO SCALE

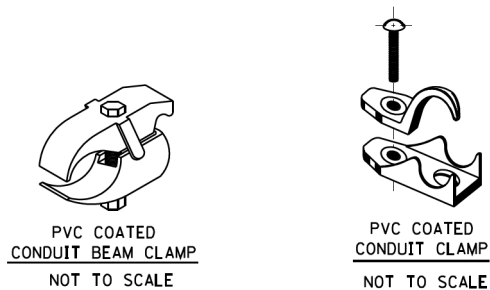

PVC COATED CONDUIT BEAM CLAMP NOT TO SCALE

PVC COATED CONDUIT CLAMP NOT TO SCALE

NOTES:

1. LIQUID TIGHT FLEXIBLE METAL CONDUIT, MAXIMUM LENGTH 6'-0", TYPICAL FOR EACH INSTANCE AS SHOWN, PROVIDE PVC COATED RIGID GALVANIZED STEEL CONDUIT AS REQUIRED NOT TO EXCEED 6'-0" OF FLEXIBLE LIQUID TIGHT METAL CONDUIT. LIQUID TIGHT FLEXIBLE METAL CONDUIT WILL BE INCLUDED IN THE COST OF THE CONDUIT ATTACHED TO STRUCTURE, OF THE CORRESPONDING DIA., GALVANIZED STEEL, PVC COATED PAY ITEM EXCEPT THAT THE COST OF THE 3/4" DIA. RIGID STEEL CONDUIT AND 3/4" DIA. FLEXIBLE CONDUIT SHALL BE INCLUDED IN THE LUMINAIRE INSTALLATION.
2. UNDERPASS LUMINAIRE MOUNTED TO FACE OF PIER OR ABUTMENT WALL. MOUNTING HEIGHT OF 1" BELOW THE TOP OF PIER OR ABUTMENT WALL TYPICAL FOR ALL PIER/ABUTMENT MOUNTED UNDERPASS LUMINAIRES UNLESS OTHERWISE NOTED.
3. EXPANSION ANCHOR, POWDER ACTUATED FASTENERS WILL NOT BE ALLOWED. EXPANSION ANCHOR MUST BE SIZED IN ACCORDANCE WITH MANUFACTURERS REQUIREMENTS.
4. SECURE THE CONDUIT WITH PVC COATED CONDUIT CLAMPS OR CONDUIT BEAM CLAMPS AS SHOWN AT 5'-0" INTERVALS FOR LATERALS AND WITHIN 2'-0" MAXIMUM FROM ANY JUNCTION BOX, FLEXIBLE CONDUIT, OR CHANGE IN DIRECTION. ALL PVC COATED CONDUIT CLAMPS OR BEAM CLAMPS SHALL BE INCLUDED WITH THE COST OF THE CONDUIT ATTACHED TO STRUCTURE, OF THE CORRESPONDING DIA., GALVANIZED STEEL, PVC COATED PAY ITEM.
5. THE CONCRETE ENCASED CONDUIT TRANSITION SHALL BE INCLUDED IN THE COST OF THE GALVANIZED RIGID STEEL CONDUIT PAY ITEMS.
6. ALL CONDUIT ATTACHED TO STRUCTURE SHALL BE PVC COATED RIGID STEEL CONDUIT (PVCC RGC) TYPICAL.

FILE NAME = W:\diststd\22x34\be902.dgn

USER NAME = gegl1enobt  
 PLOT SCALE = 50.000 ' / IN.  
 PLOT DATE = 1/4/2008

DESIGNED -  
 DRAWN -  
 CHECKED -  
 DATE -

REVISED - 01-25-05  
 REVISED -  
 REVISED -  
 REVISED -

STATE OF ILLINOIS  
 DEPARTMENT OF TRANSPORTATION

PIER /ABUTMENT MOUNTED UNDERPASS  
 LUMINAIRE INSTALLATION DETAILS

SCALE: NONE SHEET NO. 1 OF 1 SHEETS STA. TO STA.

| F.A.P. RTE.                                     | SECTION     | COUNTY             | TOTAL SHEETS | SHEET NO. |
|---|-------------|--------------------|--------------|-----------|
|   | 2013-038B-R | COOK               | 821          | 248       |
| BE-902  |             | CONTRACT NO. 60J16 |              |           |
| FED. ROAD DIST. NO. 1 ILLINOIS FED. AID PROJECT |             |                    |              |           |



**GENERAL NOTES**

- Fasteners shall be ASTM A325 Type 1, mechanically galvanized bolts. Bolts 7/8" diameter, holes 15/16" diameter, unless otherwise noted.
- Calculated weight of Structural Steel =  
M270 Grade 36: 33,320 lbs  
M270 Grade 50: 404,760 lbs
- No field welding is permitted except as specified in the contract documents.
- Reinforcement bars designated (E) shall be epoxy coated.
- If the Contractor elects to use cantilever forming brackets on the exterior beams or girders, the brackets shall be placed at the same locations required for the hardwood blocks in Article 503.06(b) of the Standard Specifications. If additional cantilever forming brackets are required, hardwood blocking shall be wedged between the exterior and first interior beam at each of these additional bracket locations.
- Bearing seat surfaces shall be constructed or adjusted to the designated elevations within a tolerance of 1/8 in. (0.01 ft.). Adjustment shall be made by either grinding the surface or by shimming the bearings.
- The existing structural steel contains lead. The Contractor shall take appropriate precautions to deal with the presence of lead on this project.
- Plan dimensions and details relative to existing plans are subject to nominal construction variations. The Contractor shall field verify existing dimensions and details affecting new construction and make necessary approved adjustments prior to construction or ordering of materials. Such variations shall not be cause for additional compensation for a change in scope of work, however, the Contractor will be paid for the quantity actually furnished at the unit price bid for the work.
- The Organic Zinc Rich Primer/Epoxy/Urethane Paint System shall be used for painting of new structural steel except where otherwise noted. The entire system shall be shop applied, with the exception of the exterior surface and the bottom of the bottom flange of fascia girders, masked off connections surfaces, and field installed fasteners and damaged areas shall be touched up and finish coated in the field. The color of the final finish coat for all interior steel surfaces shall be Gray, Munsell No. 5B 7/1. The color of the final finish coat for the exterior and bottom flange of the fascia girders shall be Reddish Brown, Munsell No. 2.5YR 3/4.
- Stage I and Stage II shown in the plans correspond to Stage IA and Stage IB, respectively, shown in the Maintenance of Traffic Plans.

2" P.J.F. (Per Article 1051.09 of the Standard Specifications) full width and vertically at edges bonded to abutment cap with suitable adhesive as recommended by supplier.

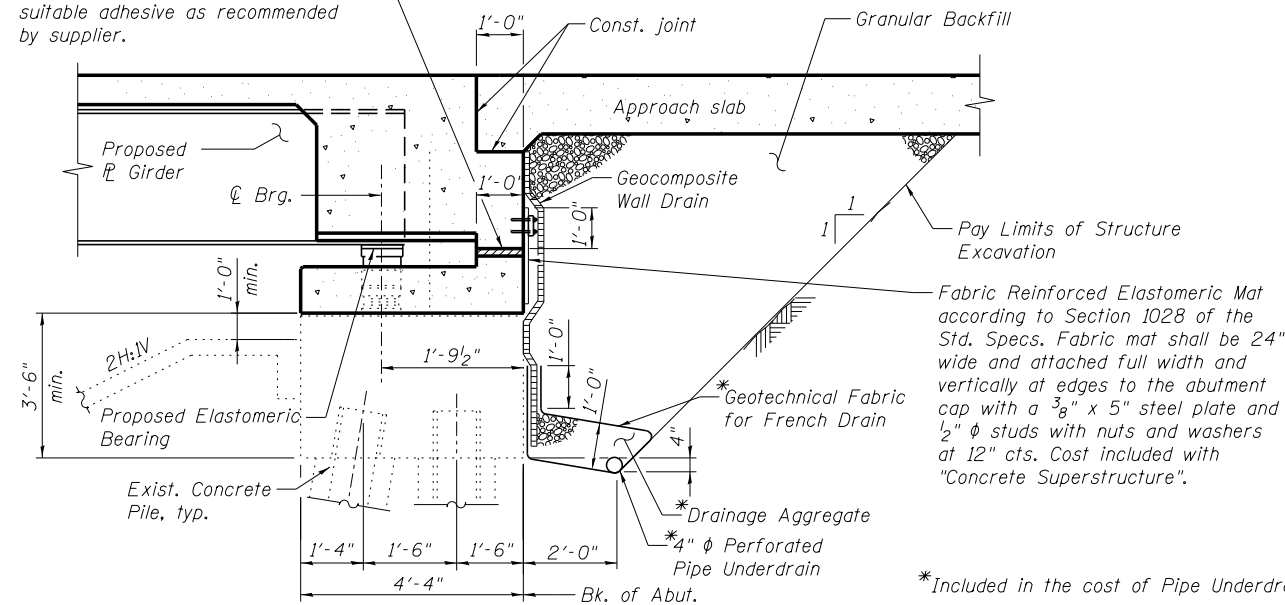

**SECTION THRU ABUTMENTS**

\*Included in the cost of Pipe Underdrains for Structures.

All drainage system components shall extend to 2'-0" from the end of each wingwall except an outlet pipe shall extend until intersecting with the side slopes. The pipes shall drain into concrete headwalls. (See Article 601.05 of the Standard Specifications and Highway Standard 601101).

**INDEX OF SHEETS**

- SA1 General Plan
- SA2 General Notes, Index of Sheets and Total Bill of Material
- SA3 Stage I Construction Details and Temporary Sheet Piling
- SA4 Stage II Construction Details
- SA5 Temporary Concrete Barrier for Stage Construction
- SA6 Top of Slab Elevations (1 of 3)
- SA7 Top of Slab Elevations (2 of 3)
- SA8 Top of Slab Elevations (3 of 3)
- SA9 Top of Slab Elevations (1 of 3)
- SA10 Top of Slab Elevations (2 of 3)
- SA11 Top of Slab Elevations (3 of 3)
- SA12 Top of Approach Slab Elevations
- SA13 Top of Approach Slab Elevations
- SA14 Superstructure
- SA15 Superstructure Details
- SA16 Superstructure
- SA17 Superstructure Details
- SA18 Concrete Parapet Slipforming Option
- SA19 Semi-Integral Abutment Diaphragm Details
- SA20 Semi-Integral Abutment Diaphragm Details
- SA21 Bridge Approach Slab Details (1 of 2)
- SA22 Bridge Approach Slab Details (2 of 2)
- SA23 Bridge Approach Slab Details (1 of 2)
- SA24 Bridge Approach Slab Details (2 of 2)
- SA25 Framing Plan
- SA26 Structural Steel Details (1 of 2)
- SA27 Structural Steel Details (2 of 2)
- SA28 Elastomeric Bearing Details
- SA29 North Abutment Concrete Removal and Repair Details
- SA30 South Abutment Concrete Removal and Repair Details
- SA31 North Abutment Modification Details
- SA32 South Abutment Modification Details
- SA33 North Abutment Concrete Removal and Repair Details
- SA34 South Abutment Concrete Removal and Repair Details
- SA35 North Abutment Modification Details
- SA36 South Abutment Modification Details
- SA37 Pier Concrete Removal and Repair Details
- SA38 Pier Concrete Removal and Repair Details
- SA39 Pier Modification Details
- SA40 Bar Splicer Assembly and Mechanical Splicer Details

For existing bridge plans, see Sheets SAX1 thru SAX25 immediately following Sheet SA40.

**TOTAL BILL OF MATERIAL**

| ITEM  | UNIT  | SUPER   | SUB    | TOTAL   |
|---|-------|---------|--------|---------|
| Removal of Existing Superstructures No. 1                               | Each  | 1       |        | 1       |
| Removal of Existing Superstructures No. 2                               | Each  | 1       |        | 1       |
| Concrete Removal  | Cu Yd |         | 112.2  | 112.2   |
| Slope Wall Removal  | Sq Yd |         | 8      | 8       |
| Protective Shield   | Sq Yd | 931     |        | 931     |
| Structure Excavation  | Cu Yd |         | 392    | 392     |
| Floor Drains  | Each  | 8       |        | 8       |
| Concrete Structures   | Cu Yd |         | 145.7  | 145.7   |
| Concrete Superstructure   | Cu Yd | 718.6   |        | 718.6   |
| Bridge Deck Grooving  | Sq Yd | 2,142   |        | 2,142   |
| Protective Coat   | Sq Yd | 2,780   |        | 2,780   |
| * Furnishing and Erecting Structural Steel                              | L Sum | 0.39    |        | 0.39    |
| Stud Shear Connectors   | Each  | 11,448  |        | 11,448  |
| Reinforcement Bars, Epoxy Coated  | Pound | 194,960 | 30,680 | 225,640 |
| Bar Splicers  | Each  | 1,564   | 208    | 1,772   |
| Slope Wall 4 Inch   | Sq Yd |         | 8      | 8       |
| Name Plates   | Each  | 2       |        | 2       |
| Elastomeric Bearing Assembly, Type I                                    | Each  | 24      |        | 24      |
| Elastomeric Bearing Assembly, Type II                                   | Each  | 12      |        | 12      |
| Anchor Bolts, 1"  | Each  | 72      |        | 72      |
| Anchor Bolts, 1 3/4" (Modified)   | Each  | 24      |        | 24      |
| ** Epoxy Crack Injection  | Foot  |         | 18     | 18      |
| Geocomposite Wall Drain   | Sq Yd |         | 104    | 104     |
| ** Structural Repair of Concrete (Depth Equal to or Less Than 5 Inches) | Sq Ft |         | 75     | 75      |
| ** Structural Repair of Concrete (Depth Greater Than 5 Inches)          | Sq Ft |         | 5      | 5       |
| Temporary Sheet Piling  | Sq Ft |         | 1,488  | 1,488   |
| Pipe Underdrains for Structures 4"                                      | Foot  |         | 274    | 274     |
| Granular Backfill for Structures  | Cu Yd |         | 384    | 384     |

\* Remainder of this item is installed with other structures in this Contract. See other structures for remaining quantity.

\*\* Quantity includes a contingency (above the amounts shown in the bills of material) to account for uncertainties associated with the condition of the existing substructure and the age of the original inspections (2008-2009). Actual repair areas will be determined by the Engineer in the field.

STATION 104+81.00  
RE-BUILT 20\_\_ BY  
STATE OF ILLINOIS  
FAP 372-SEC. 2013-038B-R  
LOADING HL-93  
STRUCTURE NO. 016-1000

STATION 104+81.00  
RE-BUILT 20\_\_ BY  
STATE OF ILLINOIS  
FAP 372-SEC. 2013-038B-R  
LOADING HL-93  
STRUCTURE NO. 016-1001

**SB NAME PLATE**  
(See Std. 515001)

**NB NAME PLATE**  
(See Std. 515001)

Existing Name Plate shall be cleaned and relocated next to the new Name Plate. Cost included with Name Plates.

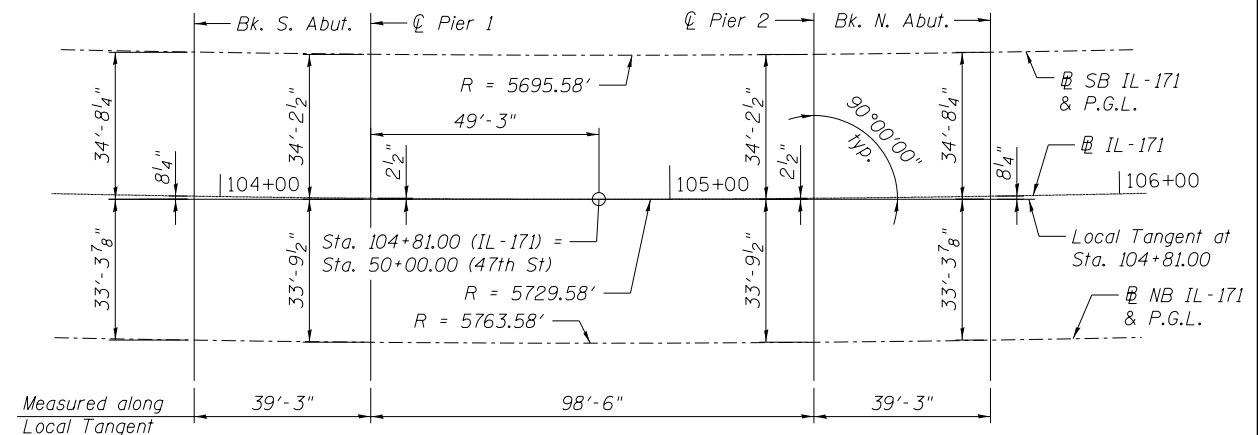

**OFFSET SKETCH**



Alfred Benesch & Company  
205 North Michigan Avenue, Suite 2400  
Chicago, Illinois 60601  
312-565-0450 Job No. 10093

|  |                     |                |             |
|--|---------------------|----------------|-------------|
| FILE NAME = 0161000_60J16_002_gennotes.dgn | USER NAME = jsurber | DESIGNED - JOB | REVISIONS - |
|  |                     | CHECKED - DJM  | REVISIONS - |
|  |                     | DRAWN - MAK    | REVISIONS - |
|  |                     | CHECKED - RMM  | REVISIONS - |
|  |                     |                |             |

**STATE OF ILLINOIS  
DEPARTMENT OF TRANSPORTATION**

**GENERAL NOTES, INDEX OF SHEETS AND TOTAL BILL OF MATERIAL  
STRUCTURE NO. 016-1000/1001**

SHEET NO. SA2 OF SA40 SHEETS

| F.A.P. RTE.               | SECTION     | COUNTY | TOTAL SHEETS       | SHEET NO. |
|---------------------------|-------------|--------|--------------------|-----------|
| 372                       | 2013-038B-R | COOK   | 821                | 250       |
| ILLINOIS FED. AID PROJECT |             |        | CONTRACT NO. 60J16 |           |

X:\100005\10093\Eng\_Docs\_Phase\_1\11\SN\_016\_1000\_1001\_1st\_Ave\_over\_47th\_St\Final\0161000\_60J16\_002\_gennotes.dgn 9:18:55 AM 7/14/2014

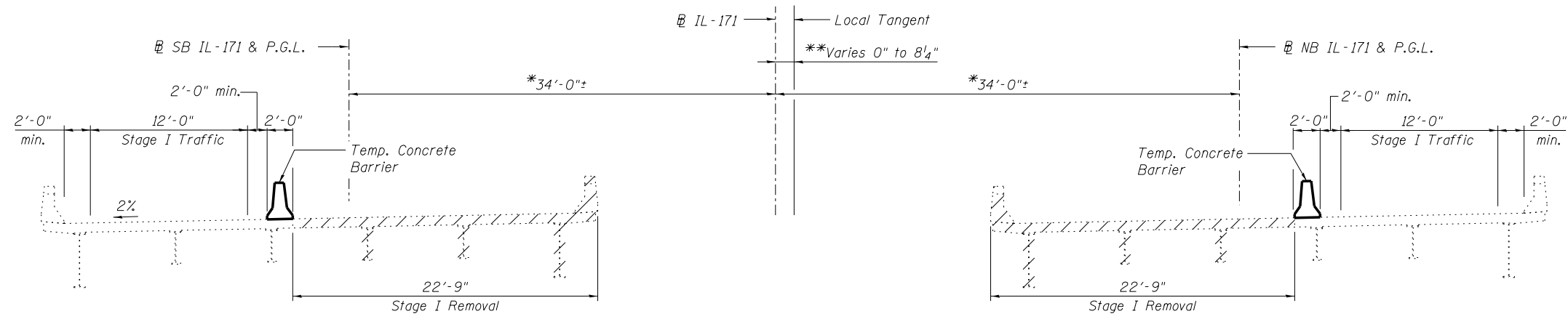

**STAGE I REMOVAL**  
(Looking North)

\*Measured radial to  $\mathbb{E}$  and P.G.L.'s., field verify.  
 \*\*Local Tangent is tangent to  $\mathbb{E}$  IL-171 at Sta. 104+81.00.

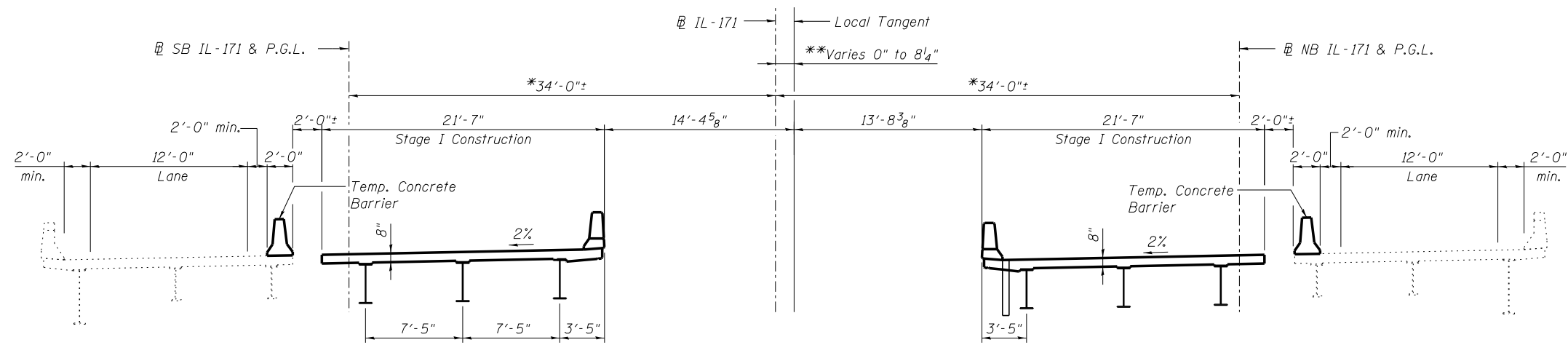

**STAGE I CONSTRUCTION**  
(Looking North)

**LEGEND**

Indicates Removal of Existing Superstructure

**BILL OF MATERIAL**

| ITEM                   | UNIT    | TOTAL |
|------------------------|---------|-------|
| Temporary Sheet Piling | Sq. Ft. | 1,488 |
|                        |         |       |

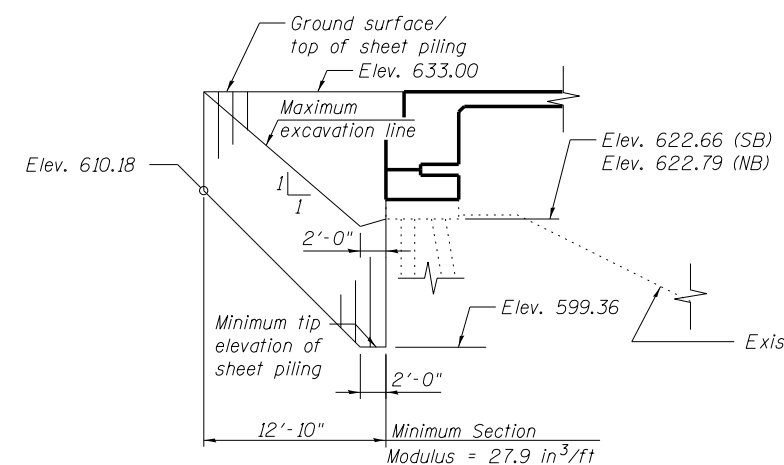

**TEMPORARY SHEET PILING**  
(at South Abutment)

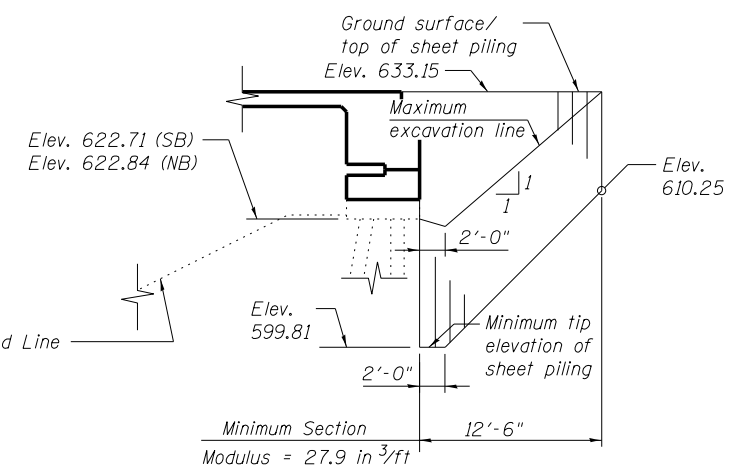

**TEMPORARY SHEET PILING**  
(at North Abutment)

**NOTES:**

1. If the Contractor chooses to alter the temporary cantilevered sheet piling design requirements shown on the plans, a design submittal including plan details and calculations will be required for review and acceptance by the Engineer.
2. See sheet SA5 for details of Temporary Concrete Barrier. For quantity, see Roadway Plans.

**benesch**  
engineers · scientists · planners  
 Alfred Benesch & Company  
 205 North Michigan Avenue, Suite 2400  
 Chicago, Illinois 60601  
 312-565-0450 Job No. 10093

|   |                      |                |             |
|---|----------------------|----------------|-------------|
| FILE NAME = 0161000_60J16_003_staging_1.dgn | USER NAME = tjenicke | DESIGNED - DJM | REVISIONS - |
|   |                      | CHECKED - GJK  | REVISIONS - |
|   |                      | DRAWN - MAK    | REVISIONS - |
|   |                      | CHECKED - RMM  | REVISIONS - |
|   |                      |                |             |

**STATE OF ILLINOIS**  
**DEPARTMENT OF TRANSPORTATION**

**STAGE I CONSTRUCTION DETAILS AND TEMPORARY SHEET PILING**  
**STRUCTURE NO. 016-1000/1001**

| F.A.P. RTE.               | SECTION     | COUNTY | TOTAL SHEETS | SHEET NO. |
|---------------------------|-------------|--------|--------------|-----------|
| 372                       | 2013-038B-R | COOK   | 821          | 251       |
| CONTRACT NO. 60J16        |             |        |              |           |
| ILLINOIS FED. AID PROJECT |             |        |              |           |

SHEET NO. SA3 OF SA40 SHEETS

X:\1000005\10093\Eng\_Docs\_Phase\_1\1001\_1st\_Ave\_over\_47th\_St\Final\0161000\_60J16\_003\_staging\_1.dgn  
 2:27:53 PM  
 6/23/2014

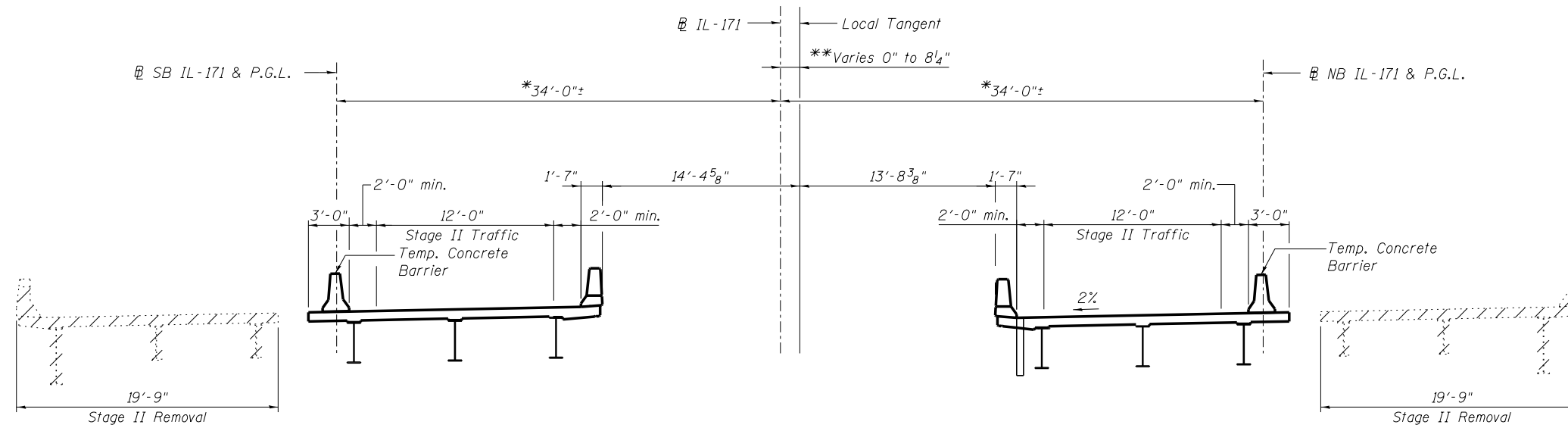

**STAGE II REMOVAL**  
(Looking North)

\*Measured radial to  $\text{IL-171}$  and P.G.L.'s., field verify.  
 \*\*Local Tangent is tangent to  $\text{IL-171}$  at Sta. 104+81.00.

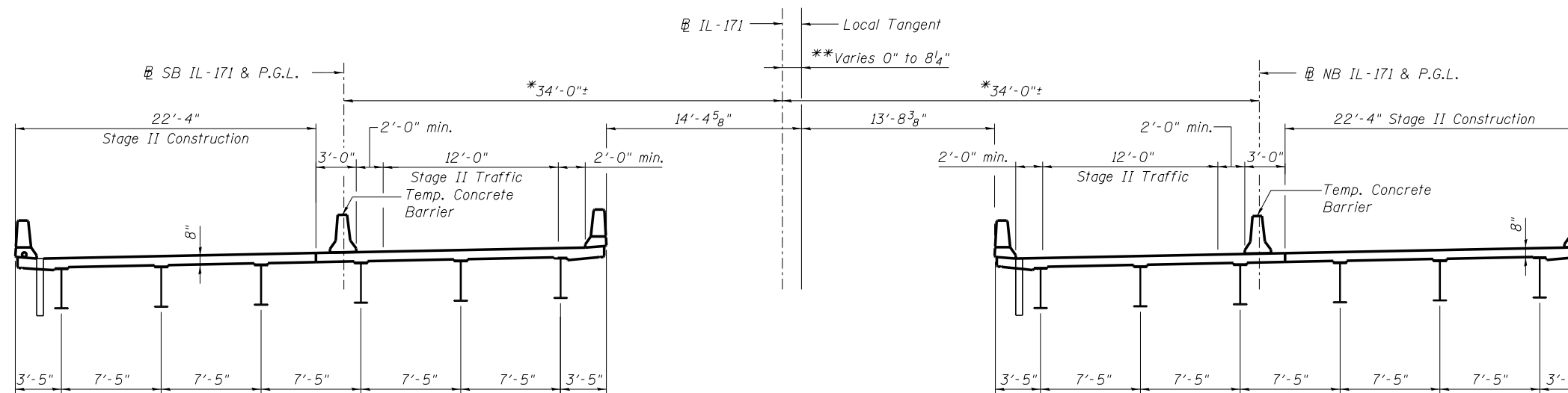

**STAGE II CONSTRUCTION**  
(Looking North)

**NOTE:**  
 See sheet SA5 for details of Temporary Concrete Barrier. For quantity, see Roadway Plans.

**LEGEND**

Indicates Removal of Existing Superstructure

**benesch**  
 engineers · scientists · planners  
 Alfred Benesch & Company  
 205 North Michigan Avenue, Suite 2400  
 Chicago, Illinois 60601  
 312-565-0450 Job No. 10093

|                                 |                        |                |           |
|---------------------------------|------------------------|----------------|-----------|
| FILE NAME =                     | USER NAME = tjenicke   | DESIGNED - DJM | REVISED - |
| 0161000_60J16_004_staging_2.dgn |                        | CHECKED - RMM  | REVISED - |
|                                 | PLOT SCALE =           | DRAWN - MAK    | REVISED - |
|                                 | PLOT DATE = 12/20/2012 | CHECKED - RMM  | REVISED - |

**STATE OF ILLINOIS**  
**DEPARTMENT OF TRANSPORTATION**

**STAGE II CONSTRUCTION DETAILS**  
**STRUCTURE NO. 016-1000/1001**

SHEET NO. SA4 OF SA40 SHEETS

| F.A.P. RTE.               | SECTION     | COUNTY | TOTAL SHEETS       | SHEET NO. |
|---------------------------|-------------|--------|--------------------|-----------|
| 372                       | 2013-038B-R | COOK   | 821                | 252       |
|                           |             |        | CONTRACT NO. 60J16 |           |
| ILLINOIS FED. AID PROJECT |             |        |                    |           |

X:\1000005\100093\Eng\_Docs\_Phase\_II\SN\_016\_1000\_1001\_1st\_Ave\_over\_47th\_St\Final\0161000\_60J16\_004\_staging\_2.dgn  
 2:27:54 PM  
 6/23/2014



When "A" is 3'-6" or less, the temporary concrete barrier shall be anchored to the new slab according to Detail I or Detail II. No anchorage is required when "A" is greater than 3'-6".

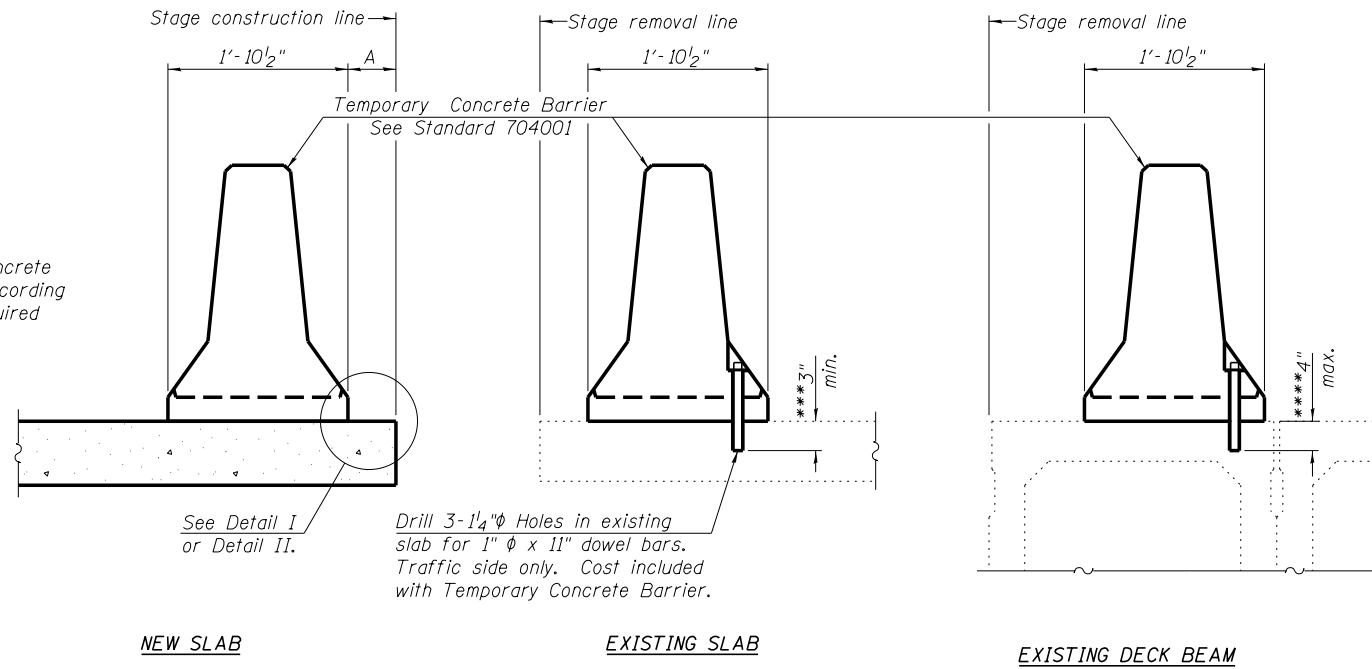

**SECTIONS THRU SLAB OR DECK BEAM**

**NOTES**

Detail I - With Bar Splicer or Couplers:  
Connect one (1) 1" x 7" x "W" steel  $\bar{L}$  to the top layer of couplers with 2- $\frac{5}{8}$ " $\phi$  bolts screwed to coupler at approximate  $\bar{C}$  of each barrier panel.

Detail II - With Extended Reinforcement Bars:  
Connect one (1) 1" x 7" x "W" steel  $\bar{L}$  to the concrete slab or concrete wearing surface with 2- $\frac{5}{8}$ " $\phi$  Expansion Anchors or cast in place inserts spaced between the top layer of reinforcement at approximate  $\bar{C}$  of each barrier panel.

Cost of anchorage is included with Temporary Concrete Barrier. The 1" x 7" x "W" plate shall not be removed until stage II construction forms and all reinforcement bars are in place and the concrete is ready to be placed.

\*\*\* Dimension shown is minimum required embedment into concrete. If hot-mix asphalt wearing surface is present, minimum embedment shall be in addition to wearing surface depth.

\*\*\*\* If existing deck beam is to remain in place after stage construction, embedment shall only be into wearing surface and not into existing deck beam concrete.

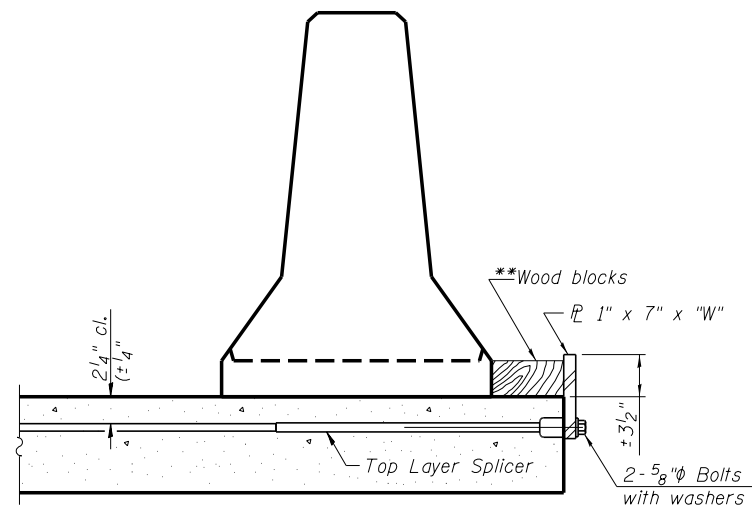

**DETAIL I**

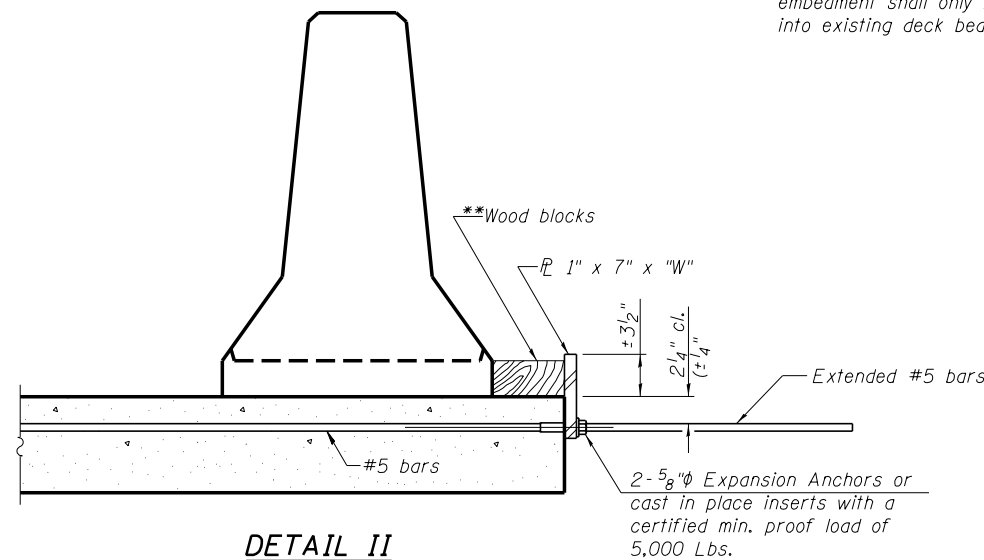

**DETAIL II**

\*\* Wood blocks may be omitted when required to provide minimum stage traffic lane width. When the wood blocks are omitted, the concrete barrier shall be in direct contact with the steel retainer plate.

"W" = Top bars spacing + 4"

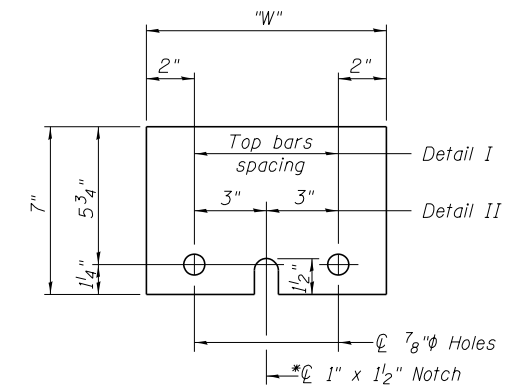

**STEEL RETAINER  $\bar{L}$  1" x 7" x "W"**

\* Required only with Detail II



Alfred Benesch & Company  
205 North Michigan Avenue, Suite 2400  
Chicago, Illinois 60601  
312-565-0450 Job No. 10093

R-27

7-1-10

FILE NAME = 0161000\_60J16\_005\_temponcbar.dgn

USER NAME = jsurber  
DESIGNED - MAK  
CHECKED - RMM  
DRAWN - MAK  
PLOT SCALE =  
PLOT DATE = 12/20/2012

REVISOR -  
REVISION -  
REVISOR -  
REVISION -  
REVISOR -  
REVISION -

STATE OF ILLINOIS  
DEPARTMENT OF TRANSPORTATION

TEMPORARY CONCRETE BARRIER FOR STAGE CONSTRUCTION  
STRUCTURE NO. 016-1000/1001

SHEET NO. SA5 OF SA40 SHEETS

| F.A.P. RTE.        | SECTION     | COUNTY | TOTAL SHEETS | SHEET NO. |
|--------------------|-------------|--------|--------------|-----------|
| 372                | 2013-038B-R | COOK   | 821          | 253       |
| CONTRACT NO. 60J16 |             |        |              |           |

ILLINOIS FED. AID PROJECT

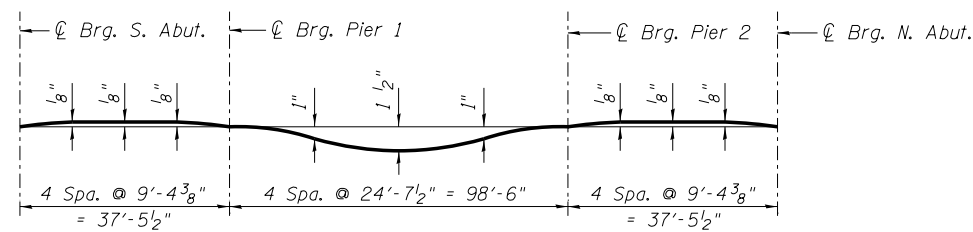
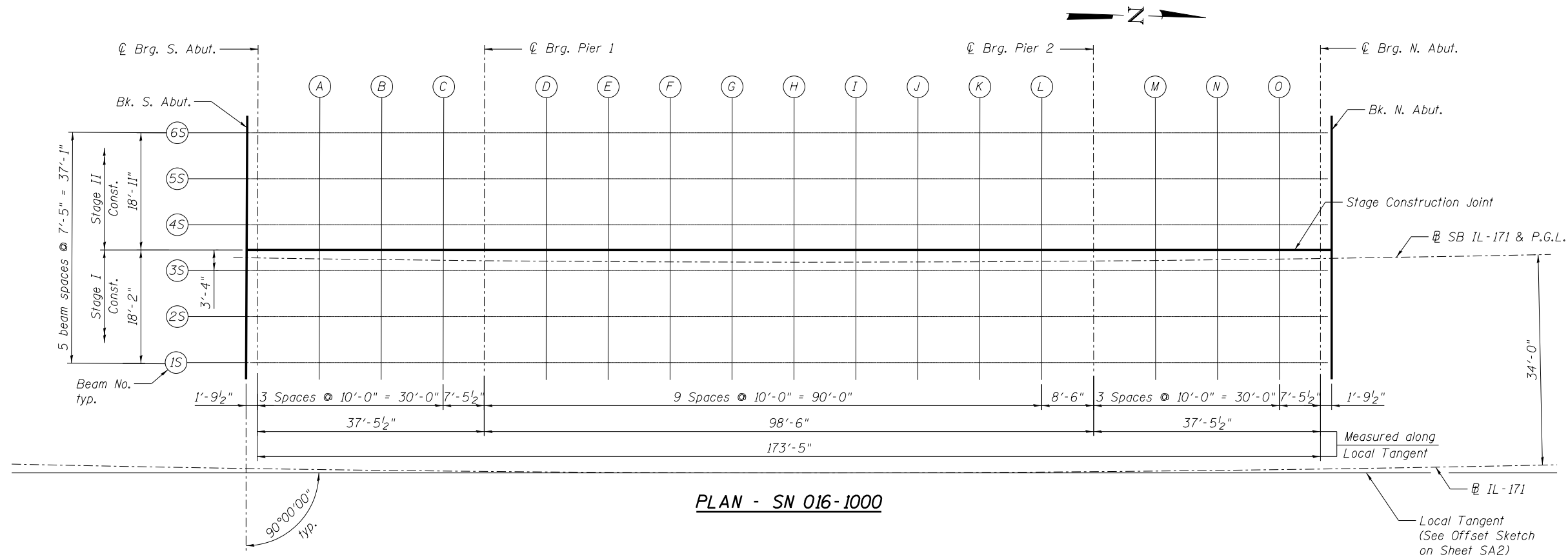

**DEAD LOAD DEFLECTION DIAGRAM**

(Includes weight of concrete only.)

Note: The above deflections are not for use in the field if the Engineer is working from the "Theoretical Grade Elevations Adjusted For Dead Load Deflection".

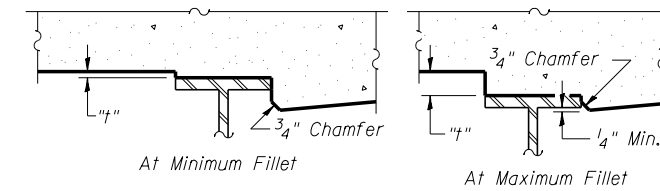

To determine "t": After all structural steel has been erected, elevations of the top flanges of the beams shall be taken at intervals shown above. These elevations subtracted from the "Theoretical Grade Elevations Adjusted for Dead Load Deflection" on sheets SA7 and SA8, minus 8" slab thickness, equals the fillet heights "t" above top flange of beams.

**FILLET HEIGHTS**

|                                   |                        |                |           |
|-----------------------------------|------------------------|----------------|-----------|
| FILE NAME =                       | USER NAME = jsurber    | DESIGNED - JOB | REVISED - |
| 0161000.60J16.006.slabelevs.1.dgn |                        | CHECKED - RMM  | REVISED - |
|                                   | PLOT SCALE =           | DRAWN - MAK    | REVISED - |
|                                   | PLOT DATE = 12/20/2012 | CHECKED - RMM  | REVISED - |

| F.A.P. RTE.               | SECTION     | COUNTY | TOTAL SHEETS       | SHEET NO. |
|---------------------------|-------------|--------|--------------------|-----------|
| 372                       | 2013-038B-R | COOK   | 821                | 254       |
|                           |             |        | CONTRACT NO. 60J16 |           |
| ILLINOIS FED. AID PROJECT |             |        |                    |           |

**BEAM 1S**

| Location        | Station   | Offset | Theoretical Grade Elevations | Theoretical Grade Elevations Adjusted For Dead Load Deflection |
|-----------------|-----------|--------|------------------------------|--|
| BK. S. ABUT.    | 103+92.23 | 16.88  | 633.32                       | 633.32   |
| ☉ BRG. S. ABUT. | 103+94.03 | 16.86  | 633.33                       | 633.33   |
| A               | 104+04.06 | 16.71  | 633.35                       | 633.35   |
| B               | 104+14.09 | 16.59  | 633.38                       | 633.37   |
| C               | 104+24.12 | 16.48  | 633.40                       | 633.39   |
| ☉ BRG. PIER 1   | 104+31.60 | 16.41  | 633.41                       | 633.41   |
| D               | 104+41.63 | 16.33  | 633.43                       | 633.46   |
| E               | 104+51.66 | 16.27  | 633.44                       | 633.51   |
| F               | 104+61.69 | 16.23  | 633.45                       | 633.55   |
| G               | 104+71.72 | 16.21  | 633.46                       | 633.58   |
| H               | 104+81.75 | 16.20  | 633.47                       | 633.60   |
| I               | 104+91.78 | 16.21  | 633.47                       | 633.59   |
| J               | 105+01.81 | 16.24  | 633.47                       | 633.57   |
| K               | 105+11.85 | 16.28  | 633.47                       | 633.53   |
| L               | 105+21.88 | 16.34  | 633.46                       | 633.49   |
| ☉ BRG. PIER 2   | 105+30.40 | 16.41  | 633.46                       | 633.46   |
| M               | 105+40.43 | 16.51  | 633.45                       | 633.45   |
| N               | 105+50.46 | 16.62  | 633.44                       | 633.43   |
| O               | 105+60.49 | 16.75  | 633.42                       | 633.42   |
| ☉ BRG. N. ABUT. | 105+67.97 | 16.86  | 633.41                       | 633.41   |
| BK. N. ABUT.    | 105+69.77 | 16.88  | 633.41                       | 633.41   |

**BEAM 2S**

| Location        | Station   | Offset | Theoretical Grade Elevations | Theoretical Grade Elevations Adjusted For Dead Load Deflection |
|-----------------|-----------|--------|------------------------------|--|
| BK. S. ABUT.    | 103+92.12 | 9.47   | 633.17                       | 633.17   |
| ☉ BRG. S. ABUT. | 103+93.92 | 9.44   | 633.18                       | 633.18   |
| A               | 104+03.96 | 9.30   | 633.21                       | 633.20   |
| B               | 104+14.00 | 9.17   | 633.23                       | 633.22   |
| C               | 104+24.04 | 9.06   | 633.25                       | 633.24   |
| ☉ BRG. PIER 1   | 104+31.53 | 8.99   | 633.26                       | 633.26   |
| D               | 104+41.58 | 8.92   | 633.28                       | 633.31   |
| E               | 104+51.62 | 8.86   | 633.29                       | 633.36   |
| F               | 104+61.67 | 8.81   | 633.31                       | 633.40   |
| G               | 104+71.71 | 8.79   | 633.31                       | 633.43   |
| H               | 104+81.75 | 8.78   | 633.32                       | 633.44   |
| I               | 104+91.80 | 8.79   | 633.32                       | 633.44   |
| J               | 105+01.84 | 8.82   | 633.32                       | 633.41   |
| K               | 105+11.89 | 8.86   | 633.32                       | 633.38   |
| L               | 105+21.93 | 8.93   | 633.32                       | 633.34   |
| ☉ BRG. PIER 2   | 105+30.47 | 8.99   | 633.31                       | 633.31   |
| M               | 105+40.51 | 9.09   | 633.30                       | 633.30   |
| N               | 105+50.55 | 9.20   | 633.29                       | 633.28   |
| O               | 105+60.60 | 9.33   | 633.27                       | 633.27   |
| ☉ BRG. N. ABUT. | 105+68.08 | 9.44   | 633.26                       | 633.26   |
| BK. N. ABUT.    | 105+69.88 | 9.47   | 633.26                       | 633.26   |

**BEAM 3S**

| Location        | Station   | Offset | Theoretical Grade Elevations | Theoretical Grade Elevations Adjusted For Dead Load Deflection |
|-----------------|-----------|--------|------------------------------|--|
| BK. S. ABUT.    | 103+92.00 | 2.05   | 633.03                       | 633.03   |
| ☉ BRG. S. ABUT. | 103+93.80 | 2.02   | 633.03                       | 633.03   |
| A               | 104+03.86 | 1.88   | 633.06                       | 633.05   |
| B               | 104+13.91 | 1.76   | 633.08                       | 633.07   |
| C               | 104+23.97 | 1.65   | 633.10                       | 633.09   |
| ☉ BRG. PIER 1   | 104+31.47 | 1.58   | 633.12                       | 633.12   |
| D               | 104+41.53 | 1.50   | 633.13                       | 633.16   |
| E               | 104+51.58 | 1.44   | 633.15                       | 633.21   |
| F               | 104+61.64 | 1.40   | 633.16                       | 633.25   |
| G               | 104+71.70 | 1.37   | 633.17                       | 633.28   |
| H               | 104+81.75 | 1.36   | 633.17                       | 633.29   |
| I               | 104+91.81 | 1.37   | 633.17                       | 633.29   |
| J               | 105+01.87 | 1.40   | 633.18                       | 633.27   |
| K               | 105+11.93 | 1.45   | 633.17                       | 633.23   |
| L               | 105+21.98 | 1.51   | 633.17                       | 633.19   |
| ☉ BRG. PIER 2   | 105+30.53 | 1.58   | 633.16                       | 633.16   |
| M               | 105+40.59 | 1.67   | 633.15                       | 633.15   |
| N               | 105+50.64 | 1.79   | 633.14                       | 633.13   |
| O               | 105+60.70 | 1.92   | 633.13                       | 633.12   |
| ☉ BRG. N. ABUT. | 105+68.20 | 2.02   | 633.11                       | 633.11   |
| BK. N. ABUT.    | 105+70.00 | 2.05   | 633.11                       | 633.11   |

**☉ SB IL-171 & P.G.L.**

| Location        | Station   | Offset | Theoretical Grade Elevations | Theoretical Grade Elevations Adjusted For Dead Load Deflection |
|-----------------|-----------|--------|------------------------------|--|
| BK. S. ABUT.    | 103+91.97 | 0.00   | 632.98                       | 632.98   |
| ☉ BRG. S. ABUT. | 103+93.77 | 0.00   | 632.99                       | 632.99   |
| A               | 104+03.83 | 0.00   | 633.02                       | 633.01   |
| B               | 104+13.89 | 0.00   | 633.05                       | 633.04   |
| C               | 104+23.95 | 0.00   | 633.07                       | 633.06   |
| ☉ BRG. PIER 1   | 104+31.46 | 0.00   | 633.08                       | 633.08   |
| D               | 104+41.52 | 0.00   | 633.10                       | 633.13   |
| E               | 104+51.58 | 0.00   | 633.12                       | 633.18   |
| F               | 104+61.64 | 0.00   | 633.13                       | 633.22   |
| G               | 104+71.69 | 0.00   | 633.14                       | 633.25   |
| H               | 104+81.75 | 0.00   | 633.14                       | 633.27   |
| I               | 104+91.81 | 0.00   | 633.15                       | 633.26   |
| J               | 105+01.87 | 0.00   | 633.15                       | 633.24   |
| K               | 105+11.93 | 0.00   | 633.14                       | 633.20   |
| L               | 105+21.99 | 0.00   | 633.14                       | 633.16   |
| ☉ BRG. PIER 2   | 105+30.54 | 0.00   | 633.13                       | 633.13   |
| M               | 105+40.60 | 0.00   | 633.12                       | 633.12   |
| N               | 105+50.67 | 0.00   | 633.10                       | 633.09   |
| O               | 105+60.73 | 0.00   | 633.09                       | 633.08   |
| ☉ BRG. N. ABUT. | 105+68.23 | 0.00   | 633.07                       | 633.07   |
| BK. N. ABUT.    | 105+70.03 | 0.00   | 633.07                       | 633.07   |

**STAGE CONSTRUCTION JOINT**

| Location        | Station   | Offset | Theoretical Grade Elevations | Theoretical Grade Elevations Adjusted For Dead Load Deflection |
|-----------------|-----------|--------|------------------------------|--|
| BK. S. ABUT.    | 103+91.95 | -1.28  | 632.96                       | 632.96   |
| ☉ BRG. S. ABUT. | 103+93.75 | -1.31  | 632.96                       | 632.96   |
| A               | 104+03.81 | -1.45  | 632.99                       | 632.98   |
| B               | 104+13.87 | -1.58  | 633.01                       | 633.00   |
| C               | 104+23.94 | -1.69  | 633.04                       | 633.03   |
| ☉ BRG. PIER 1   | 104+31.44 | -1.76  | 633.05                       | 633.05   |
| D               | 104+41.50 | -1.83  | 633.07                       | 633.09   |
| E               | 104+51.57 | -1.89  | 633.08                       | 633.14   |
| F               | 104+61.63 | -1.94  | 633.09                       | 633.18   |
| G               | 104+71.69 | -1.96  | 633.10                       | 633.22   |
| H               | 104+81.75 | -1.97  | 633.10                       | 633.23   |
| I               | 104+91.82 | -1.96  | 633.11                       | 633.22   |
| J               | 105+01.88 | -1.93  | 633.11                       | 633.20   |
| K               | 105+11.94 | -1.89  | 633.11                       | 633.16   |
| L               | 105+22.01 | -1.82  | 633.10                       | 633.12   |
| ☉ BRG. PIER 2   | 105+30.56 | -1.76  | 633.10                       | 633.10   |
| M               | 105+40.62 | -1.66  | 633.09                       | 633.09   |
| N               | 105+50.68 | -1.55  | 633.07                       | 633.06   |
| O               | 105+60.75 | -1.42  | 633.06                       | 633.05   |
| ☉ BRG. N. ABUT. | 105+68.25 | -1.31  | 633.05                       | 633.05   |
| BK. N. ABUT.    | 105+70.05 | -1.28  | 633.04                       | 633.04   |

**BEAM 4S**

| Location        | Station   | Offset | Theoretical Grade Elevations | Theoretical Grade Elevations Adjusted For Dead Load Deflection |
|-----------------|-----------|--------|------------------------------|--|
| BK. S. ABUT.    | 103+91.88 | -5.36  | 632.88                       | 632.88   |
| ☉ BRG. S. ABUT. | 103+93.69 | -5.39  | 632.88                       | 632.88   |
| A               | 104+03.76 | -5.54  | 632.91                       | 632.90   |
| B               | 104+13.83 | -5.66  | 632.93                       | 632.92   |
| C               | 104+23.89 | -5.77  | 632.95                       | 632.94   |
| ☉ BRG. PIER 1   | 104+31.40 | -5.84  | 632.97                       | 632.97   |
| D               | 104+41.47 | -5.92  | 632.98                       | 633.01   |
| E               | 104+51.54 | -5.98  | 633.00                       | 633.06   |
| F               | 104+61.61 | -6.02  | 633.01                       | 633.10   |
| G               | 104+71.68 | -6.04  | 633.02                       | 633.13   |
| H               | 104+81.76 | -6.05  | 633.02                       | 633.15   |
| I               | 104+91.83 | -6.04  | 633.03                       | 633.14   |
| J               | 105+01.90 | -6.01  | 633.03                       | 633.12   |
| K               | 105+11.97 | -5.97  | 633.02                       | 633.08   |
| L               | 105+22.04 | -5.91  | 633.02                       | 633.04   |
| ☉ BRG. PIER 2   | 105+30.60 | -5.84  | 633.01                       | 633.01   |
| M               | 105+40.66 | -5.74  | 633.00                       | 633.00   |
| N               | 105+50.73 | -5.63  | 632.99                       | 632.98   |
| O               | 105+60.80 | -5.50  | 632.98                       | 632.97   |
| ☉ BRG. N. ABUT. | 105+68.31 | -5.39  | 632.96                       | 632.96   |
| BK. N. ABUT.    | 105+70.12 | -5.36  | 632.96                       | 632.96   |



Alfred Benesch & Company  
205 North Michigan Avenue, Suite 2400  
Chicago, Illinois 60601  
312-565-0450 Job No. 10093

|                                  |                        |                |           |
|----------------------------------|------------------------|----------------|-----------|
| FILE NAME =                      | USER NAME = jsurber    | DESIGNED - JOB | REVISED - |
|                                  |                        | CHECKED - DJM  | REVISED - |
| 0161000.60J16.007.slabelvs.2.dgn |                        | DRAWN - FSM    | REVISED - |
|                                  |                        | CHECKED - RMM  | REVISED - |
|                                  | PLOT DATE = 12/20/2012 |                |           |

**STATE OF ILLINOIS  
DEPARTMENT OF TRANSPORTATION**

**TOP OF SLAB ELEVATIONS (2 OF 3)  
STRUCTURE NO. 016-1000/1001**

SHEET NO. SA7 OF SA40 SHEETS

|                           |             |        |                    |           |
|---------------------------|-------------|--------|--------------------|-----------|
| F.A.P. RTE.               | SECTION     | COUNTY | TOTAL SHEETS       | SHEET NO. |
| 372                       | 2013-038B-R | COOK   | 821                | 255       |
| ILLINOIS FED. AID PROJECT |             |        | CONTRACT NO. 60J16 |           |

9:18:57 AM X:\1000005\100093\Eng-Docs\_Phase\_1\1\SN\_016\_1000\_1001\_1st\_Ave\_over\_47th\_St\Final\0161000\_60J16\_007.slabelvs.2.dgn 7/14/2014

**BEAM 5S**

| Location        | Station   | Offset | Theoretical Grade Elevations | Theoretical Grade Elevations Adjusted For Dead Load Deflection |
|-----------------|-----------|--------|------------------------------|--|
| BK. S. ABUT.    | 103+91.77 | -12.78 | 632.73                       | 632.73   |
| ⊕ BRG. S. ABUT. | 103+93.57 | -12.81 | 632.73                       | 632.73   |
| A               | 104+03.66 | -12.95 | 632.76                       | 632.75   |
| B               | 104+13.74 | -13.08 | 632.78                       | 632.77   |
| C               | 104+23.82 | -13.19 | 632.81                       | 632.80   |
| ⊕ BRG. PIER 1   | 104+31.34 | -13.26 | 632.82                       | 632.82   |
| D               | 104+41.42 | -13.33 | 632.84                       | 632.86   |
| E               | 104+51.51 | -13.39 | 632.85                       | 632.91   |
| F               | 104+61.59 | -13.44 | 632.86                       | 632.95   |
| G               | 104+71.67 | -13.46 | 632.87                       | 632.99   |
| H               | 104+81.76 | -13.47 | 632.87                       | 633.00   |
| I               | 104+91.84 | -13.46 | 632.88                       | 632.99   |
| J               | 105+01.92 | -13.43 | 632.88                       | 632.97   |
| K               | 105+12.01 | -13.39 | 632.88                       | 632.93   |
| L               | 105+22.09 | -13.32 | 632.87                       | 632.89   |
| ⊕ BRG. PIER 2   | 105+30.66 | -13.26 | 632.87                       | 632.87   |
| M               | 105+40.74 | -13.16 | 632.86                       | 632.86   |
| N               | 105+50.83 | -13.05 | 632.84                       | 632.83   |
| O               | 105+60.91 | -12.92 | 632.83                       | 632.82   |
| ⊕ BRG. N. ABUT. | 105+68.43 | -12.81 | 632.81                       | 632.81   |
| BK. N. ABUT.    | 105+70.23 | -12.78 | 632.81                       | 632.81   |

**BEAM 6S**

| Location        | Station   | Offset | Theoretical Grade Elevations | Theoretical Grade Elevations Adjusted For Dead Load Deflection |
|-----------------|-----------|--------|------------------------------|--|
| BK. S. ABUT.    | 103+91.65 | -20.20 | 632.58                       | 632.58   |
| ⊕ BRG. S. ABUT. | 103+93.46 | -20.22 | 632.58                       | 632.58   |
| A               | 104+03.55 | -20.37 | 632.61                       | 632.60   |
| B               | 104+13.65 | -20.49 | 632.64                       | 632.62   |
| C               | 104+23.75 | -20.60 | 632.66                       | 632.65   |
| ⊕ BRG. PIER 1   | 104+31.27 | -20.67 | 632.67                       | 632.67   |
| D               | 104+41.37 | -20.75 | 632.69                       | 632.72   |
| E               | 104+51.47 | -20.81 | 632.70                       | 632.77   |
| F               | 104+61.56 | -20.85 | 632.71                       | 632.81   |
| G               | 104+71.66 | -20.88 | 632.72                       | 632.84   |
| H               | 104+81.76 | -20.89 | 632.73                       | 632.86   |
| I               | 104+91.85 | -20.88 | 632.73                       | 632.85   |
| J               | 105+01.95 | -20.85 | 632.73                       | 632.82   |
| K               | 105+12.05 | -20.80 | 632.73                       | 632.79   |
| L               | 105+22.14 | -20.74 | 632.72                       | 632.75   |
| ⊕ BRG. PIER 2   | 105+30.73 | -20.67 | 632.72                       | 632.72   |
| M               | 105+40.82 | -20.58 | 632.71                       | 632.71   |
| N               | 105+50.92 | -20.46 | 632.69                       | 632.68   |
| O               | 105+61.01 | -20.33 | 632.68                       | 632.67   |
| ⊕ BRG. N. ABUT. | 105+68.54 | -20.22 | 632.67                       | 632.67   |
| BK. N. ABUT.    | 105+70.35 | -20.20 | 632.66                       | 632.66   |

|             |                                   |              |            |            |     |           |  |
|-------------|-----------------------------------|--------------|------------|------------|-----|-----------|--|
| FILE NAME = | 0161000.60J16.008.slabelevs.3.dgn | USER NAME =  | jsurber    | DESIGNED - | JOB | REVISED - |  |
|             |                                   |              |            | CHECKED -  | DJM | REVISED - |  |
|             |                                   | PLOT SCALE = |            | DRAWN -    | FSM | REVISED - |  |
|             |                                   | PLOT DATE =  | 12/20/2012 | CHECKED -  | RMM | REVISED - |  |

|                           |             |        |                    |           |
|---------------------------|-------------|--------|--------------------|-----------|
| F.A.P. RTE.               | SECTION     | COUNTY | TOTAL SHEETS       | SHEET NO. |
| 372                       | 2013-038B-R | COOK   | 821                | 256       |
| ILLINOIS FED. AID PROJECT |             |        | CONTRACT NO. 60J16 |           |

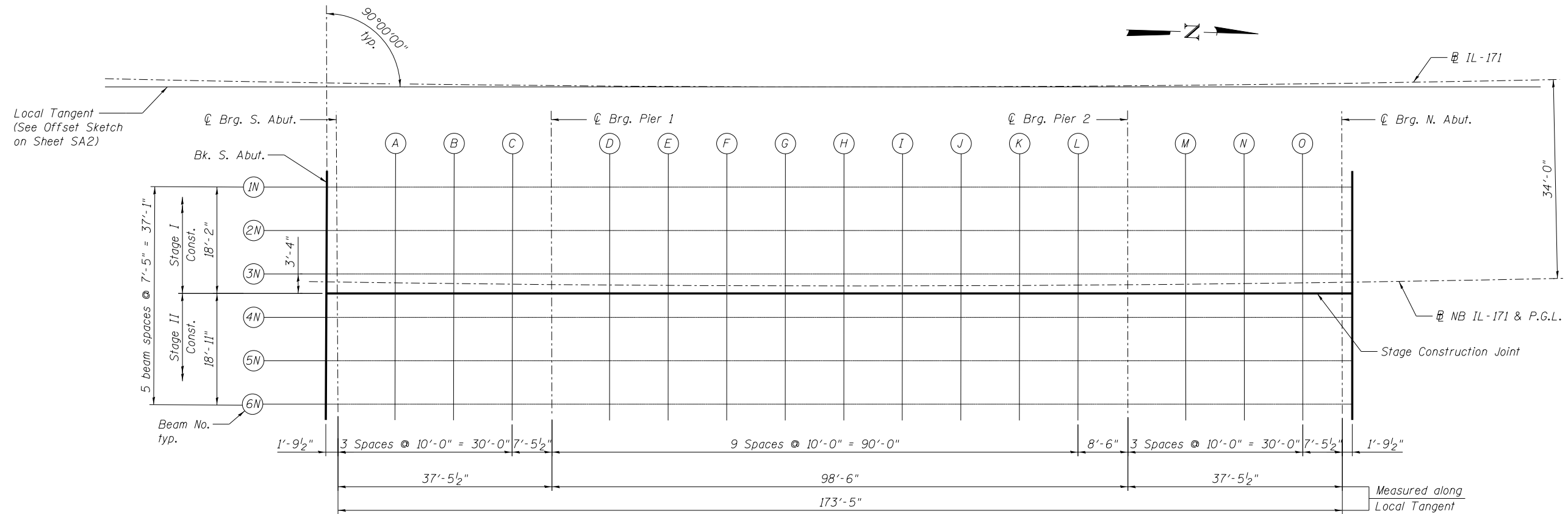

PLAN - SN 016-1001

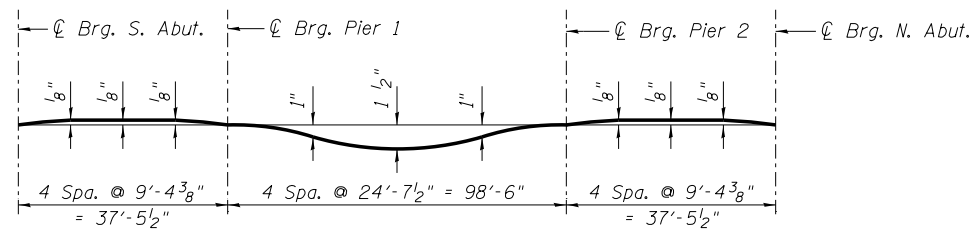

**DEAD LOAD DEFLECTION DIAGRAM**

(Includes weight of concrete only.)

Note: The above deflections are not for use in the field if the Engineer is working from the "Theoretical Grade Elevations Adjusted For Dead Load Deflection".

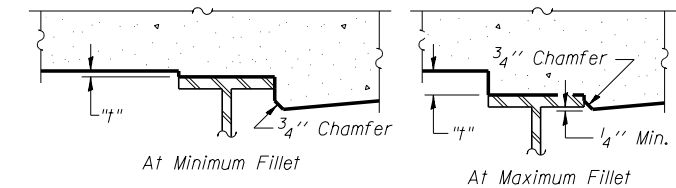

To determine "t": After all structural steel has been erected, elevations of the top flanges of the beams shall be taken at intervals shown above. These elevations subtracted from the "Theoretical Grade Elevations Adjusted for Dead Load Deflection" on sheets SA10 and SA11, minus 8" slab thickness, equals the fillet heights "t" above top flange of beams.

**FILLET HEIGHTS**

|                                   |                        |                |           |
|-----------------------------------|------------------------|----------------|-----------|
| FILE NAME =                       | USER NAME = jsurber    | DESIGNED - JOB | REVISED - |
| 0161000.60J16.009.slabelevs.1.dgn |                        | CHECKED - RMM  | REVISED - |
|                                   | PLOT SCALE =           | DRAWN - MAK    | REVISED - |
|                                   | PLOT DATE = 12/20/2012 | CHECKED - RMM  | REVISED - |

| F.A.P. RTE.        | SECTION     | COUNTY | TOTAL SHEETS              | SHEET NO. |
|--------------------|-------------|--------|---------------------------|-----------|
| 372                | 2013-038B-R | COOK   | 821                       | 257       |
| CONTRACT NO. 60J16 |             |        | ILLINOIS FED. AID PROJECT |           |

**BEAM 1N**

Table with 5 columns: Location, Station, Offset, Theoretical Grade Elevations, Theoretical Grade Elevations Adjusted For Dead Load Deflection. Rows include BK. S. ABUT., BRG. S. ABUT. (A-C), BRG. PIER 1 (D-L), BRG. PIER 2 (M-O), BRG. N. ABUT., and BK. N. ABUT.

**BEAM 2N**

Table with 5 columns: Location, Station, Offset, Theoretical Grade Elevations, Theoretical Grade Elevations Adjusted For Dead Load Deflection. Rows include BK. S. ABUT., BRG. S. ABUT. (A-C), BRG. PIER 1 (D-L), BRG. PIER 2 (M-O), BRG. N. ABUT., and BK. N. ABUT.

**BEAM 3N**

Table with 5 columns: Location, Station, Offset, Theoretical Grade Elevations, Theoretical Grade Elevations Adjusted For Dead Load Deflection. Rows include BK. S. ABUT., BRG. S. ABUT. (A-C), BRG. PIER 1 (D-L), BRG. PIER 2 (M-O), BRG. N. ABUT., and BK. N. ABUT.

**@ NB IL-171 & P.G.L.**

Table with 5 columns: Location, Station, Offset, Theoretical Grade Elevations, Theoretical Grade Elevations Adjusted For Dead Load Deflection. Rows include BK. S. ABUT., BRG. S. ABUT. (A-C), BRG. PIER 1 (D-L), BRG. PIER 2 (M-O), BRG. N. ABUT., and BK. N. ABUT.

**STAGE CONSTRUCTION JOINT**

Table with 5 columns: Location, Station, Offset, Theoretical Grade Elevations, Theoretical Grade Elevations Adjusted For Dead Load Deflection. Rows include BK. S. ABUT., BRG. S. ABUT. (A-C), BRG. PIER 1 (D-L), BRG. PIER 2 (M-O), BRG. N. ABUT., and BK. N. ABUT.

**BEAM 4N**

Table with 5 columns: Location, Station, Offset, Theoretical Grade Elevations, Theoretical Grade Elevations Adjusted For Dead Load Deflection. Rows include BK. S. ABUT., BRG. S. ABUT. (A-C), BRG. PIER 1 (D-L), BRG. PIER 2 (M-O), BRG. N. ABUT., and BK. N. ABUT.



Alfred Benesch & Company  
205 North Michigan Avenue, Suite 2400  
Chicago, Illinois 60601  
312-565-0450 Job No. 10093

Table with 4 columns: USER NAME, DESIGNED, CHECKED, PLOT SCALE, PLOT DATE, JOB, JOB, JOB, JOB.

STATE OF ILLINOIS  
DEPARTMENT OF TRANSPORTATION

TOP OF SLAB ELEVATIONS (2 OF 3)  
STRUCTURE NO. 016-1000/1001

SHEET NO. SA10 OF SA40 SHEETS

Table with 5 columns: F.A.P. RTE., SECTION, COUNTY, TOTAL SHEETS, SHEET NO. Values: 372, 2013-038B-R, COOK, 821, 258.

ILLINOIS FED. AID PROJECT  
CONTRACT NO. 60J16

9:40:45 AM X:\1000005\100093\Eng\_Docs\_Phase\_1\1\SN\_016\_1000\_1001\_1st\_Ave\_over\_47th\_St\Final\0161000\_60J16\_010\_slabelevs\_2.dgn 7/29/2014

**BEAM 5N**

| Location        | Station   | Offset | Theoretical Grade Elevations | Theoretical Grade Elevations Adjusted For Dead Load Deflection |
|-----------------|-----------|--------|------------------------------|--|
| BK. S. ABUT.    | 103+93.22 | 13.46  | 633.32                       | 633.32   |
| ⊕ BRG. S. ABUT. | 103+95.00 | 13.43  | 633.32                       | 633.32   |
| A               | 104+04.92 | 13.29  | 633.35                       | 633.34   |
| B               | 104+14.83 | 13.17  | 633.37                       | 633.36   |
| C               | 104+24.75 | 13.06  | 633.39                       | 633.38   |
| ⊕ BRG. PIER 1   | 104+32.15 | 12.99  | 633.40                       | 633.40   |
| D               | 104+42.07 | 12.91  | 633.42                       | 633.45   |
| E               | 104+51.99 | 12.86  | 633.43                       | 633.49   |
| F               | 104+61.91 | 12.81  | 633.44                       | 633.54   |
| G               | 104+71.82 | 12.79  | 633.45                       | 633.57   |
| H               | 104+81.74 | 12.78  | 633.45                       | 633.58   |
| I               | 104+91.66 | 12.79  | 633.46                       | 633.57   |
| J               | 105+01.58 | 12.82  | 633.46                       | 633.55   |
| K               | 105+11.50 | 12.86  | 633.46                       | 633.51   |
| L               | 105+21.42 | 12.93  | 633.45                       | 633.47   |
| ⊕ BRG. PIER 2   | 105+29.85 | 12.99  | 633.44                       | 633.44   |
| M               | 105+39.77 | 13.09  | 633.43                       | 633.43   |
| N               | 105+49.69 | 13.20  | 633.42                       | 633.41   |
| O               | 105+59.60 | 13.32  | 633.41                       | 633.40   |
| ⊕ BRG. N. ABUT. | 105+67.00 | 13.43  | 633.40                       | 633.40   |
| BK. N. ABUT.    | 105+68.78 | 13.46  | 633.39                       | 633.39   |

**BEAM 6N**

| Location        | Station   | Offset | Theoretical Grade Elevations | Theoretical Grade Elevations Adjusted For Dead Load Deflection |
|-----------------|-----------|--------|------------------------------|--|
| BK. S. ABUT.    | 103+93.34 | 20.88  | 633.47                       | 633.47   |
| ⊕ BRG. S. ABUT. | 103+95.11 | 20.85  | 633.47                       | 633.47   |
| A               | 104+05.02 | 20.71  | 633.50                       | 633.49   |
| B               | 104+14.92 | 20.58  | 633.52                       | 633.51   |
| C               | 104+24.82 | 20.48  | 633.54                       | 633.53   |
| ⊕ BRG. PIER 1   | 104+32.21 | 20.41  | 633.55                       | 633.55   |
| D               | 104+42.12 | 20.33  | 633.57                       | 633.60   |
| E               | 104+52.02 | 20.27  | 633.58                       | 633.65   |
| F               | 104+61.93 | 20.23  | 633.59                       | 633.69   |
| G               | 104+71.84 | 20.21  | 633.60                       | 633.72   |
| H               | 104+81.74 | 20.20  | 633.60                       | 633.73   |
| I               | 104+91.65 | 20.21  | 633.61                       | 633.73   |
| J               | 105+01.56 | 20.24  | 633.61                       | 633.70   |
| K               | 105+11.46 | 20.28  | 633.60                       | 633.66   |
| L               | 105+21.37 | 20.34  | 633.60                       | 633.62   |
| ⊕ BRG. PIER 2   | 105+29.79 | 20.41  | 633.59                       | 633.59   |
| M               | 105+39.69 | 20.50  | 633.58                       | 633.58   |
| N               | 105+49.60 | 20.61  | 633.57                       | 633.56   |
| O               | 105+59.50 | 20.74  | 633.56                       | 633.55   |
| ⊕ BRG. N. ABUT. | 105+66.89 | 20.85  | 633.54                       | 633.54   |
| BK. N. ABUT.    | 105+68.66 | 20.88  | 633.54                       | 633.54   |



Alfred Benesch & Company  
205 North Michigan Avenue, Suite 2400  
Chicago, Illinois 60601  
312-565-0450 Job No. 10093

|             |                                   |              |            |            |     |           |  |
|-------------|-----------------------------------|--------------|------------|------------|-----|-----------|--|
| FILE NAME = | 0161000_60J16_011.slabelevs.3.dgn | USER NAME =  | jsurber    | DESIGNED - | JOB | REVISED - |  |
|             |                                   |              |            | CHECKED -  | DJM | REVISED - |  |
|             |                                   | PLOT SCALE = |            | DRAWN -    | FMS | REVISED - |  |
|             |                                   | PLOT DATE =  | 12/20/2012 | CHECKED -  | RMM | REVISED - |  |

**STATE OF ILLINOIS  
DEPARTMENT OF TRANSPORTATION**

**TOP OF SLAB ELEVATIONS (3 OF 3)  
STRUCTURE NO. 016-1000/1001**

SHEET NO. SA11 OF SA40 SHEETS

| F.A.P. RTE.               | SECTION     | COUNTY | TOTAL SHEETS       | SHEET NO. |
|---------------------------|-------------|--------|--------------------|-----------|
| 372                       | 2013-038B-R | COOK   | 821                | 259       |
|                           |             |        | CONTRACT NO. 60J16 |           |
| ILLINOIS FED. AID PROJECT |             |        |                    |           |

**EAST EDGE OF SHOULDER**

| Location                   | Station   | Offset | Theoretical Grade Elevations |
|----------------------------|-----------|--------|------------------------------|
| S. END OF SOUTH APPR. SLAB | 103+63.17 | 18.42  | 633.25                       |
| S1                         | 103+73.20 | 18.63  | 633.29                       |
| S2                         | 103+83.24 | 18.86  | 633.33                       |
| N. END OF SOUTH APPR. SLAB | 103+93.27 | 19.11  | 633.37                       |
| S. END OF NORTH APPR. SLAB | 105+68.73 | 19.11  | 633.45                       |
| N1                         | 105+78.76 | 18.86  | 633.42                       |
| N2                         | 105+88.80 | 18.63  | 633.39                       |
| N. END OF NORTH APPR. SLAB | 105+98.83 | 18.42  | 633.36                       |

**@ SB IL-171 & P.G.L.**

| Location                   | Station   | Offset | Theoretical Grade Elevations |
|----------------------------|-----------|--------|------------------------------|
| S. END OF SOUTH APPR. SLAB | 103+62.79 | 0.00   | 632.88                       |
| S1                         | 103+72.85 | 0.00   | 632.92                       |
| S2                         | 103+82.91 | 0.00   | 632.96                       |
| N. END OF SOUTH APPR. SLAB | 103+92.97 | 0.00   | 632.99                       |
| S. END OF NORTH APPR. SLAB | 105+69.03 | 0.00   | 633.07                       |
| N1                         | 105+79.09 | 0.00   | 633.05                       |
| N2                         | 105+89.15 | 0.00   | 633.02                       |
| N. END OF NORTH APPR. SLAB | 105+99.21 | 0.00   | 632.99                       |

**STAGE CONSTRUCTION JOINT**

| Location                   | Station   | Offset | Theoretical Grade Elevations |
|----------------------------|-----------|--------|------------------------------|
| S. END OF SOUTH APPR. SLAB | 103+62.77 | -0.76  | 632.87                       |
| S1                         | 103+72.83 | -0.95  | 632.90                       |
| S2                         | 103+82.89 | -1.13  | 632.93                       |
| N. END OF SOUTH APPR. SLAB | 103+92.95 | -1.30  | 632.96                       |
| S. END OF NORTH APPR. SLAB | 105+69.05 | -1.30  | 633.04                       |
| N1                         | 105+79.11 | -1.13  | 633.02                       |
| N2                         | 105+89.17 | -0.95  | 633.00                       |
| N. END OF NORTH APPR. SLAB | 105+99.23 | -0.76  | 632.98                       |

**WEST EDGE OF SHOULDER**

| Location                   | Station   | Offset | Theoretical Grade Elevations |
|----------------------------|-----------|--------|------------------------------|
| S. END OF SOUTH APPR. SLAB | 103+62.32 | -22.42 | 632.43                       |
| S1                         | 103+72.42 | -22.45 | 632.47                       |
| S2                         | 103+82.52 | -22.47 | 632.50                       |
| N. END OF SOUTH APPR. SLAB | 103+92.63 | -22.47 | 632.54                       |
| S. END OF NORTH APPR. SLAB | 105+69.37 | -22.47 | 632.62                       |
| N1                         | 105+79.48 | -22.47 | 632.60                       |
| N2                         | 105+89.58 | -22.45 | 632.57                       |
| N. END OF NORTH APPR. SLAB | 105+99.68 | -22.42 | 632.54                       |

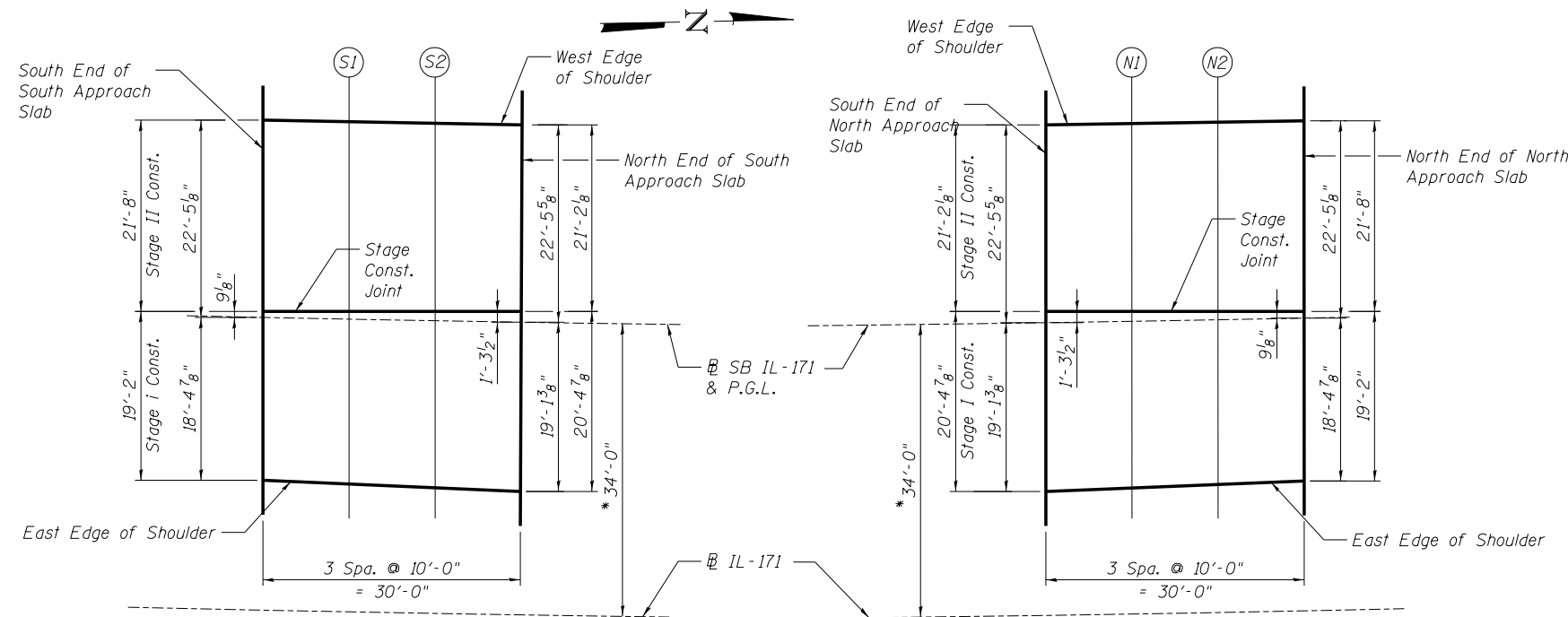

\* Measured radial to @ and P.G.L.'s.

**PLAN - SN 016-1000**  
South and North Approaches

**benesch**  
engineers · scientists · planners  
Alfred Benesch & Company  
205 North Michigan Avenue, Suite 2400  
Chicago, Illinois 60601  
312-565-0450 Job No. 10093

|                                   |                     |                |           |
|-----------------------------------|---------------------|----------------|-----------|
| FILE NAME =                       | USER NAME = jsurber | DESIGNED - JOB | REVISED - |
| 0161000_60J16_012_SB_AppS1abs.dgn |                     | CHECKED - DJM  | REVISED - |
|                                   |                     | DRAWN - MAK    | REVISED - |
|                                   |                     | CHECKED - RMM  | REVISED - |
|                                   |                     |                |           |

**STATE OF ILLINOIS**  
**DEPARTMENT OF TRANSPORTATION**

**TOP OF APPROACH SLAB ELEVATIONS**  
**STRUCTURE NO. 016-1000/1001**

|                           |             |        |                    |           |
|---------------------------|-------------|--------|--------------------|-----------|
| F.A.P. RTE.               | SECTION     | COUNTY | TOTAL SHEETS       | SHEET NO. |
| 372                       | 2013-038B-R | COOK   | 821                | 260       |
|                           |             |        | CONTRACT NO. 60J16 |           |
| ILLINOIS FED. AID PROJECT |             |        |                    |           |

SHEET NO. SA12 OF SA40 SHEETS

X:\100005\10093\Eng\_Docs\_Phase\_1\SN\_016\_1000\_1001\_1st\_Ave\_over\_47th\_St\Final\0161000\_60J16\_012\_SB\_AppS1abs.dgn 9:19:01 AM 7/14/2014



**WEST EDGE OF SHOULDER**

| Location                   | Station   | Offset | Theoretical Grade Elevations |
|----------------------------|-----------|--------|------------------------------|
| S. END OF SOUTH APPR. SLAB | 103+63.81 | -18.42 | 632.58                       |
| S1                         | 103+73.78 | -18.45 | 632.62                       |
| S2                         | 103+83.76 | -18.47 | 632.65                       |
| N. END OF SOUTH APPR. SLAB | 103+93.73 | -18.47 | 632.68                       |
| S. END OF NORTH APPR. SLAB | 105+68.27 | -18.48 | 632.75                       |
| N1                         | 105+78.24 | -18.48 | 632.73                       |
| N2                         | 105+88.22 | -18.45 | 632.71                       |
| N. END OF NORTH APPR. SLAB | 105+98.19 | -18.42 | 632.68                       |

**@ NB IL-171 & P.G.L.**

| Location                   | Station   | Offset | Theoretical Grade Elevations |
|----------------------------|-----------|--------|------------------------------|
| S. END OF SOUTH APPR. SLAB | 103+64.19 | 0.00   | 632.95                       |
| S1                         | 103+74.13 | 0.00   | 632.99                       |
| S2                         | 103+84.07 | 0.00   | 633.02                       |
| N. END OF SOUTH APPR. SLAB | 103+94.01 | 0.00   | 633.05                       |
| S. END OF NORTH APPR. SLAB | 105+67.99 | 0.00   | 633.12                       |
| N1                         | 105+77.93 | 0.00   | 633.10                       |
| N2                         | 105+87.87 | 0.00   | 633.08                       |
| N. END OF NORTH APPR. SLAB | 105+97.81 | 0.00   | 633.05                       |

**STAGE CONSTRUCTION JOINT**

| Location                   | Station   | Offset | Theoretical Grade Elevations |
|----------------------------|-----------|--------|------------------------------|
| S. END OF SOUTH APPR. SLAB | 103+64.24 | 2.48   | 633.00                       |
| S1                         | 103+74.17 | 2.28   | 633.03                       |
| S2                         | 103+84.11 | 2.11   | 633.06                       |
| N. END OF SOUTH APPR. SLAB | 103+94.04 | 1.95   | 633.09                       |
| S. END OF NORTH APPR. SLAB | 105+67.96 | 1.95   | 633.16                       |
| N1                         | 105+77.89 | 2.11   | 633.14                       |
| N2                         | 105+87.83 | 2.28   | 633.12                       |
| N. END OF NORTH APPR. SLAB | 105+97.76 | 2.48   | 633.10                       |

**EAST EDGE OF SHOULDER**

| Location                   | Station   | Offset | Theoretical Grade Elevations |
|----------------------------|-----------|--------|------------------------------|
| S. END OF SOUTH APPR. SLAB | 103+64.64 | 22.42  | 633.40                       |
| S1                         | 103+74.55 | 22.63  | 633.44                       |
| S2                         | 103+84.45 | 22.86  | 633.48                       |
| N. END OF SOUTH APPR. SLAB | 103+94.36 | 23.11  | 633.51                       |
| S. END OF NORTH APPR. SLAB | 105+67.64 | 23.10  | 633.59                       |
| N1                         | 105+77.55 | 22.85  | 633.56                       |
| N2                         | 105+87.45 | 22.63  | 633.53                       |
| N. END OF NORTH APPR. SLAB | 105+97.36 | 22.42  | 633.50                       |

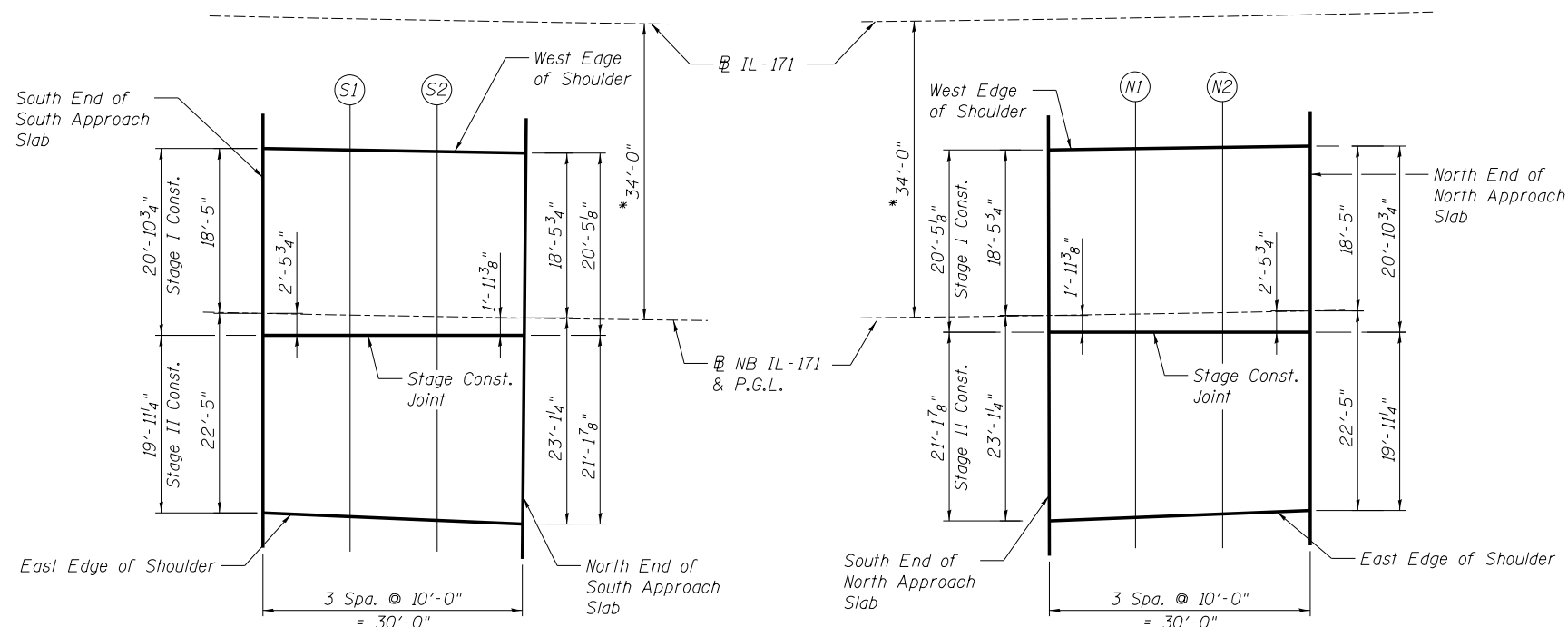
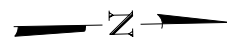

**PLAN - SN 016-1001**  
South and North Approaches

**benesch**  
engineers · scientists · planners  
Alfred Benesch & Company  
205 North Michigan Avenue, Suite 2400  
Chicago, Illinois 60601  
312-565-0450 Job No. 10093

|                        |                     |                |           |
|------------------------|---------------------|----------------|-----------|
| FILE NAME =            | USER NAME = jsurber | DESIGNED - JOB | REVISED - |
|                        |                     | CHECKED - DJM  | REVISED - |
|                        |                     | DRAWN - MAK    | REVISED - |
|                        |                     | CHECKED - RMM  | REVISED - |
| PLOT SCALE =           |                     |                |           |
| PLOT DATE = 12/20/2012 |                     |                |           |

**STATE OF ILLINOIS**  
**DEPARTMENT OF TRANSPORTATION**

**TOP OF APPROACH SLAB ELEVATIONS**  
**STRUCTURE NO. 016-1000/1001**

| F.A.P. RTE.               | SECTION     | COUNTY | TOTAL SHEETS | SHEET NO. |
|---------------------------|-------------|--------|--------------|-----------|
| 372                       | 2013-038B-R | COOK   | 821          | 261       |
| CONTRACT NO. 60J16        |             |        |              |           |
| ILLINOIS FED. AID PROJECT |             |        |              |           |

SHEET NO. SA13 OF SA40 SHEETS

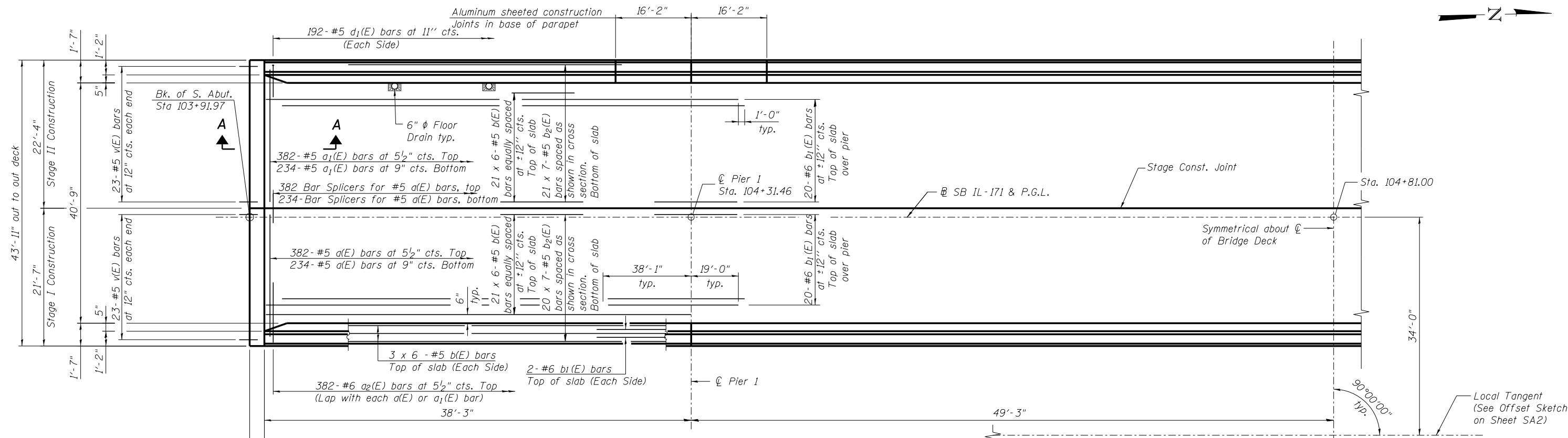
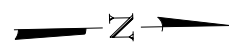

**PARTIAL PLAN - SN 016-1000**  
(SB South half shown - SB North half opposite hand)

**MINIMUM BAR LAP**  
(Slab)  
#5 bar - 3'-3"

- NOTES:**
1. See sheet SA15 for superstructure details, parapet reinforcement and Bill of Material.
  2. See sheet SA19 for Section A-A.
  3. Bars indicated thus 20x3-#5 etc. indicates 20 lines of bars with 3 lengths per line.
  4. See sheet SA1 for Floor Drain locations.
  5. See sheet SA40 for Bar Splicer Details.

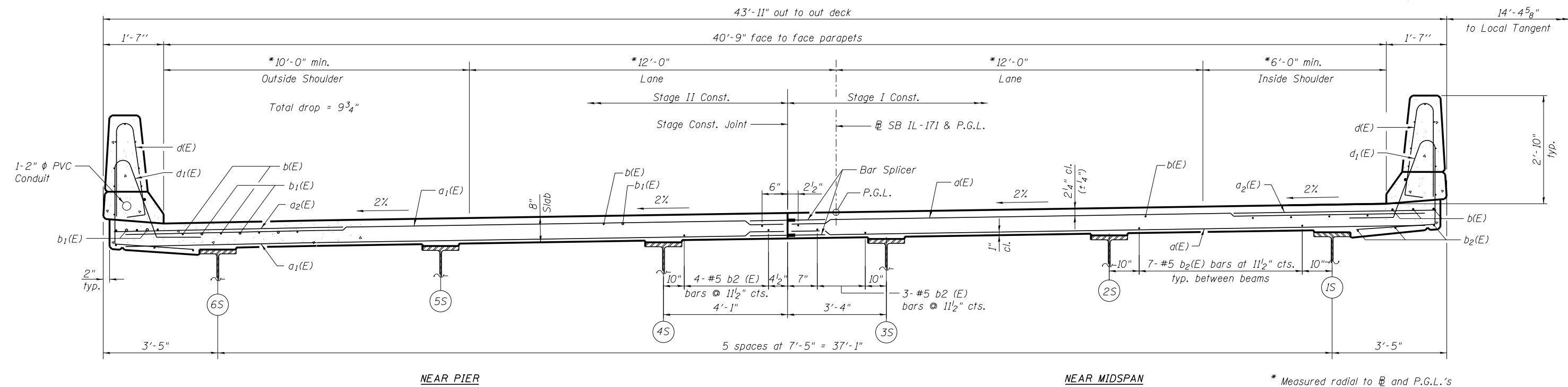

**CROSS SECTION - SN 016-1000**  
(Looking North)

**benesch**  
engineers · scientists · planners

Alfred Benesch & Company  
205 North Michigan Avenue, Suite 2400  
Chicago, Illinois 60601  
312-565-0450 Job No. 10093

|   |                     |                |             |
|---|---------------------|----------------|-------------|
| FILE NAME = 0161000_60J16_014_superstr_SB.dgn | USER NAME = jsurber | DESIGNED - JOB | REVISIONS - |
|   |                     | CHECKED - RMM  | REVISIONS - |
|   |                     | DRAWN - MAK    | REVISIONS - |
|   |                     | CHECKED - RMM  | REVISIONS - |
|   |                     |                | REVISIONS - |

**STATE OF ILLINOIS**  
**DEPARTMENT OF TRANSPORTATION**

**SUPERSTRUCTURE**  
**STRUCTURE NO. 016-1000/1001**

|                    |                     |             |                           |               |
|--------------------|---------------------|-------------|---------------------------|---------------|
| F.A.P. RE. 372     | SECTION 2013-038B-R | COUNTY COOK | TOTAL SHEETS 821          | SHEET NO. 262 |
| CONTRACT NO. 60J16 |                     |             | ILLINOIS FED. AID PROJECT |               |

X:\100005\10093\Eng\_Docs\_Phase\_1\SN\_016\_1000\_1001\_1st\_Ave\_over\_47th\_St\Final\0161000\_60J16\_014\_superstr\_SB.dgn 9:40:48 AM 7/29/2014

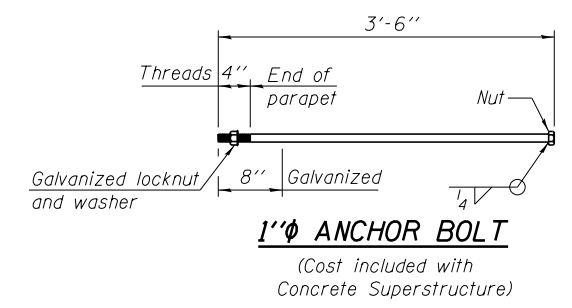
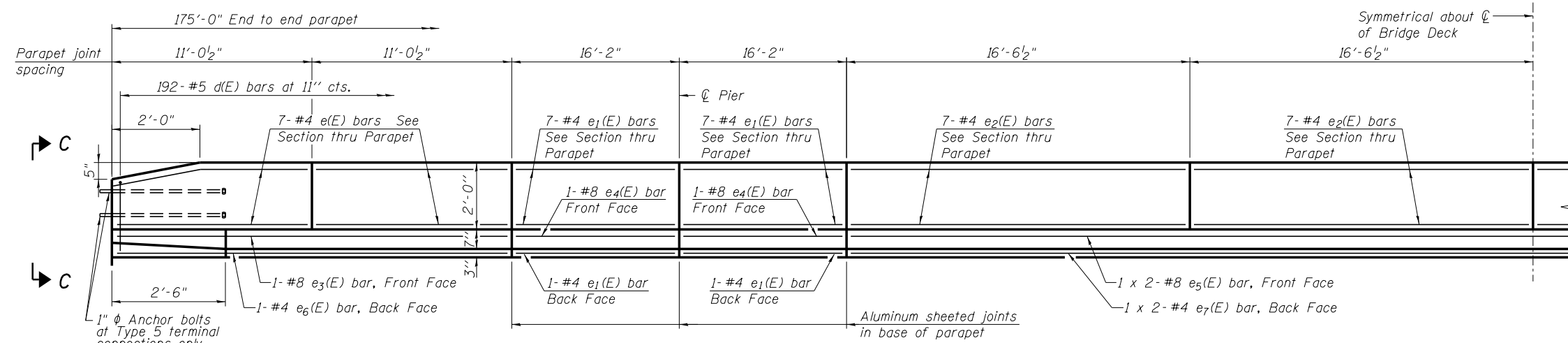

**INSIDE ELEVATION OF PARAPET - SN 016-1000**

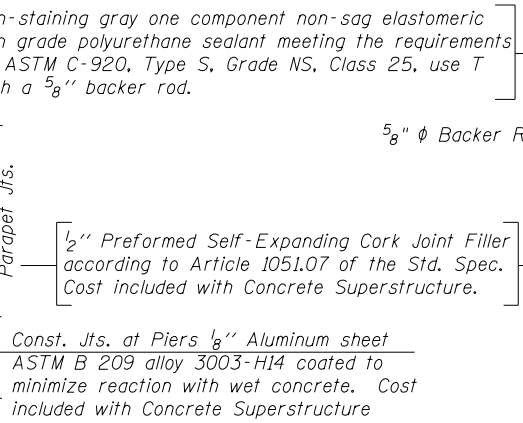
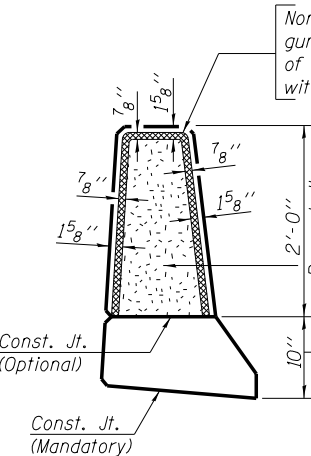
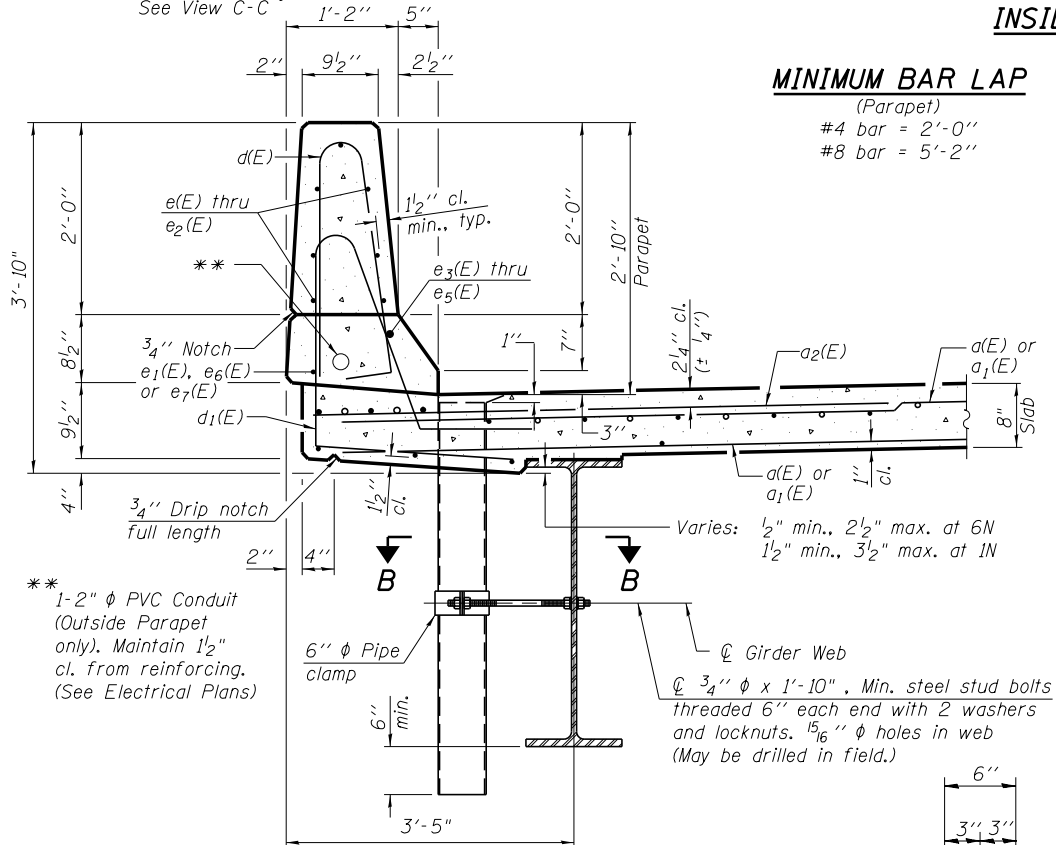

**NOTES:**

1. Drains shall be located clear of all diaphragms.
2. The exterior surfaces of the floor drains shall be painted with the finish coat as specified in Section 506 of the Standard Specifications. The exterior surfaces of the drains shall be cleaned according to the Society of Protective Coatings Spec. SSPC-SPI prior to painting.
3. Fiberglass pipe shall conform to ASTM D 2996, with short-time rupture strength hoop tensile stress of 30,000 p.s.i. minimum.
4. Galvanize clamping device according to AASHTO M232. Cost of clamping device and inserts is included with Floor Drains.

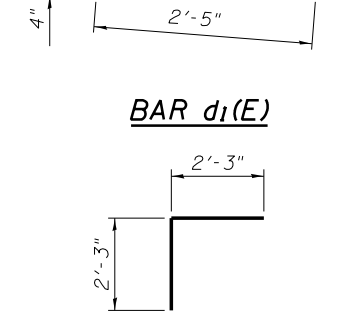
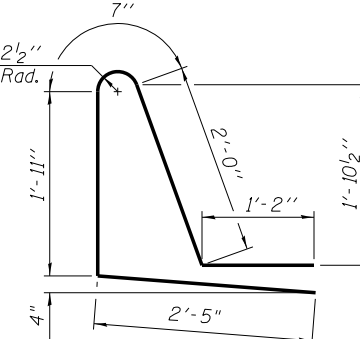
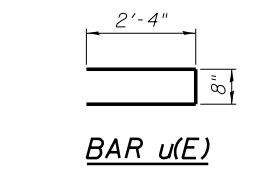
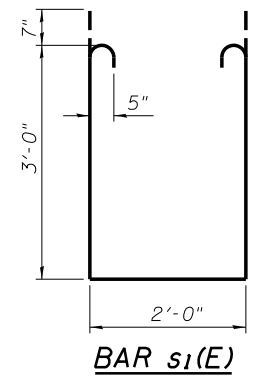
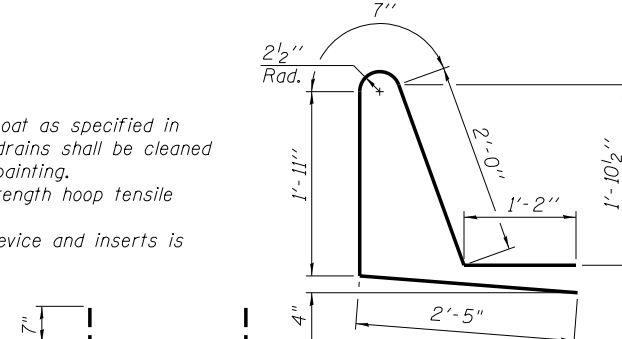
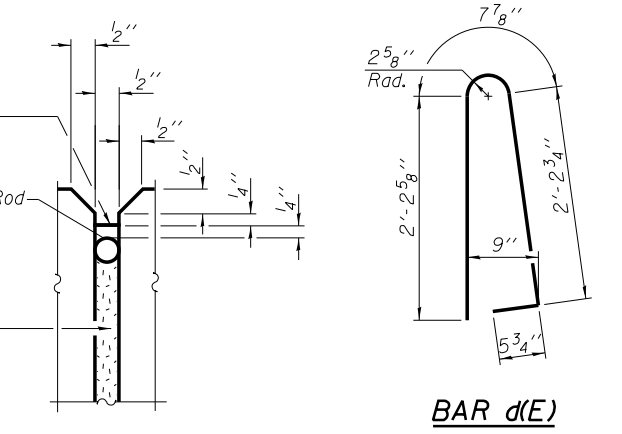
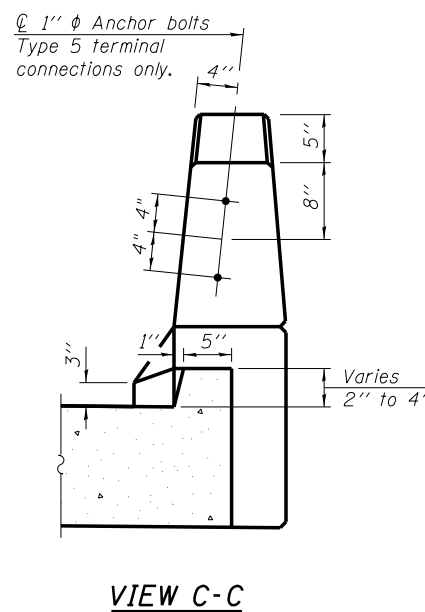
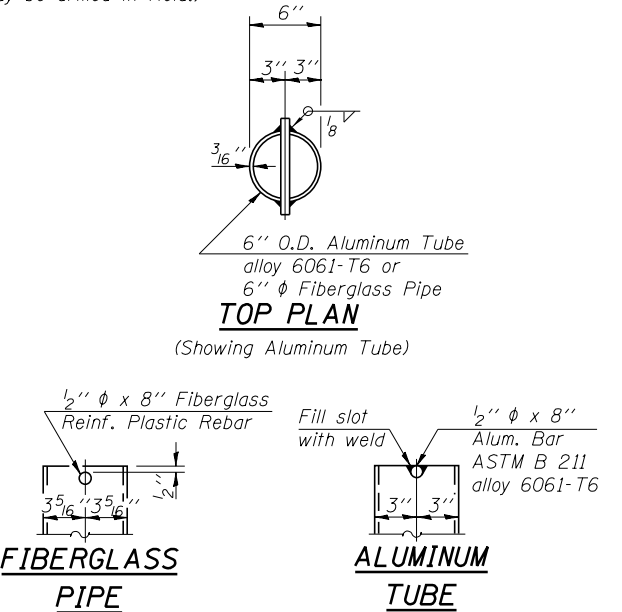
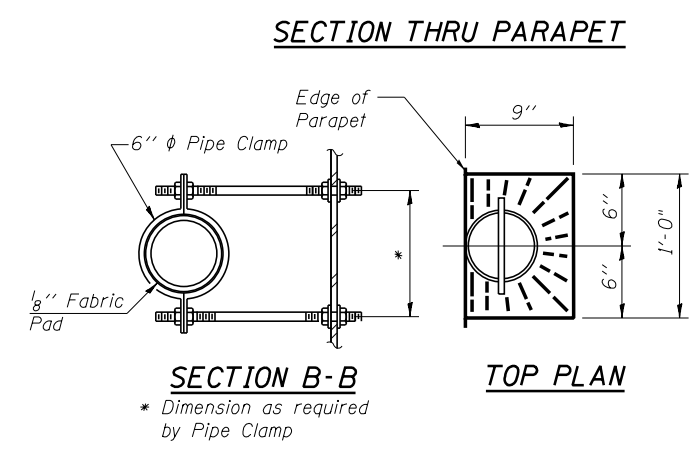

**SUPERSTRUCTURE BILL OF MATERIAL**

| Bar                              | No. | Size    | Length  | Shape |
|----------------------------------|-----|---------|---------|-------|
| d(E)                             | 616 | #5      | 21'-3"  | —     |
| a1(E)                            | 616 | #5      | 22'-0"  | —     |
| a2(E)                            | 764 | #6      | 6'-6"   | —     |
| b(E)                             | 288 | #5      | 31'-10" | —     |
| b1(E)                            | 88  | #6      | 57'-1"  | —     |
| b2(E)                            | 287 | #5      | 27'-9"  | —     |
| d(E)                             | 192 | #5      | 5'-7"   | ┌     |
| d1(E)                            | 192 | #5      | 8'-1"   | ┌     |
| m(E)                             | 24  | #5      | 4'-0"   | —     |
| m1(E)                            | 16  | #6      | 3'-0"   | —     |
| m2(E)                            | 32  | #6      | 7'-0"   | —     |
| m3(E)                            | 16  | #6      | 21'-10" | —     |
| m4(E)                            | 16  | #6      | 21'-1"  | —     |
| m5(E)                            | 8   | #6      | 2'-11"  | —     |
| m6(E)                            | 8   | #6      | 3'-8"   | —     |
| s(E)                             | 98  | #5      | 7'-5"   | ┌     |
| s1(E)                            | 84  | #5      | 9'-2"   | ┌     |
| u(E)                             | 98  | #5      | 5'-4"   | ┌     |
| e(E)                             | 56  | #4      | 10'-8"  | —     |
| e1(E)                            | 64  | #4      | 15'-10" | —     |
| e2(E)                            | 56  | #4      | 16'-2"  | —     |
| e3(E)                            | 4   | #8      | 21'-9"  | —     |
| e4(E)                            | 8   | #8      | 15'-10" | —     |
| e5(E)                            | 4   | #8      | 35'-6"  | —     |
| e6(E)                            | 4   | #4      | 21'-9"  | —     |
| e7(E)                            | 4   | #4      | 33'-11" | —     |
| v(E)                             | 92  | #5      | 4'-6"   | ┌     |
| Reinforcement Bars, Epoxy Coated |     | Pound   | 70335   |       |
| Concrete Superstructure          |     | Cu. Yd. | 242.6   |       |
| Floor Drains                     |     | Each    | 4       |       |
| Bridge Deck Grooving             |     | Sq. Yd. | 801     |       |
| Protective Coat                  |     | Sq. Yd. | 1038    |       |

Bars indicated thus 1 x 2-#8 etc. indicates 1 line of bars with 2 lengths per line.

X:\1000005\100093\Eng\_Docs\_Phase\_1\11\SN\_016\_1000\_015\_superstrdet\_SB.dgn 2/28/04 PM 6/23/2014

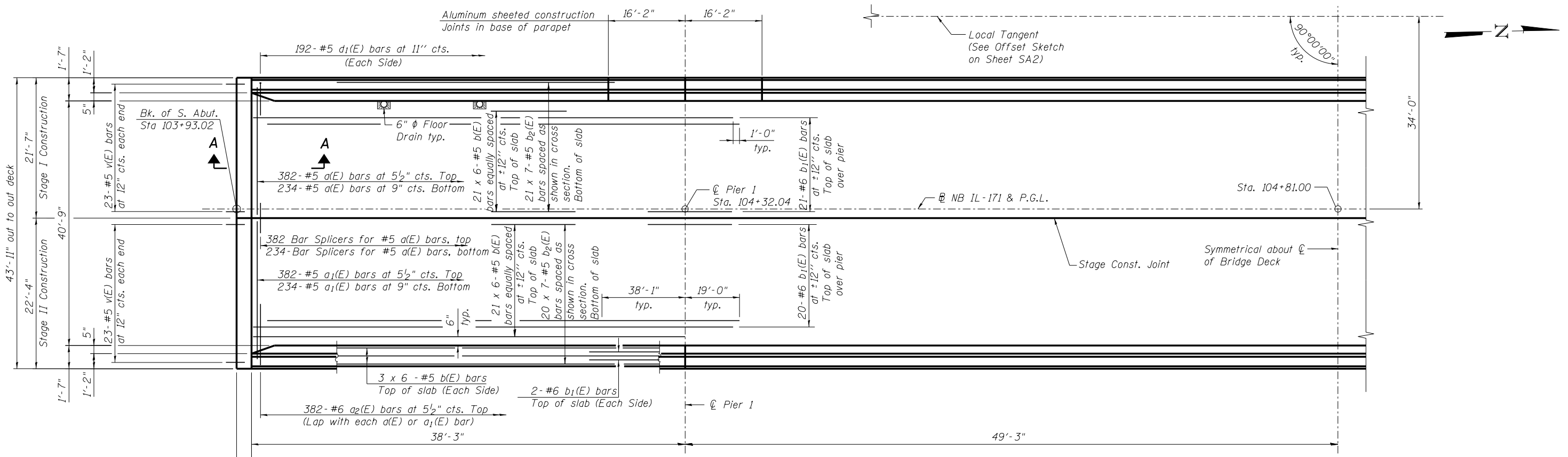

**PARTIAL PLAN - SN 016-1001**  
(NB South half shown - NB North half opposite hand)

**MINIMUM BAR LAP**  
(Slab)  
#5 bar - 3'-3"

- NOTES:**
1. See sheet SA17 for superstructure details, parapet reinforcement and Bill of Material.
  2. See sheet SA20 for Section A-A.
  3. Bars indicated thus 20x3-#5 etc. indicates 20 lines of bars with 3 lengths per line.
  4. See sheet SA1 for Floor Drain locations.
  5. See sheet SA40 for Bar Splicer Details.

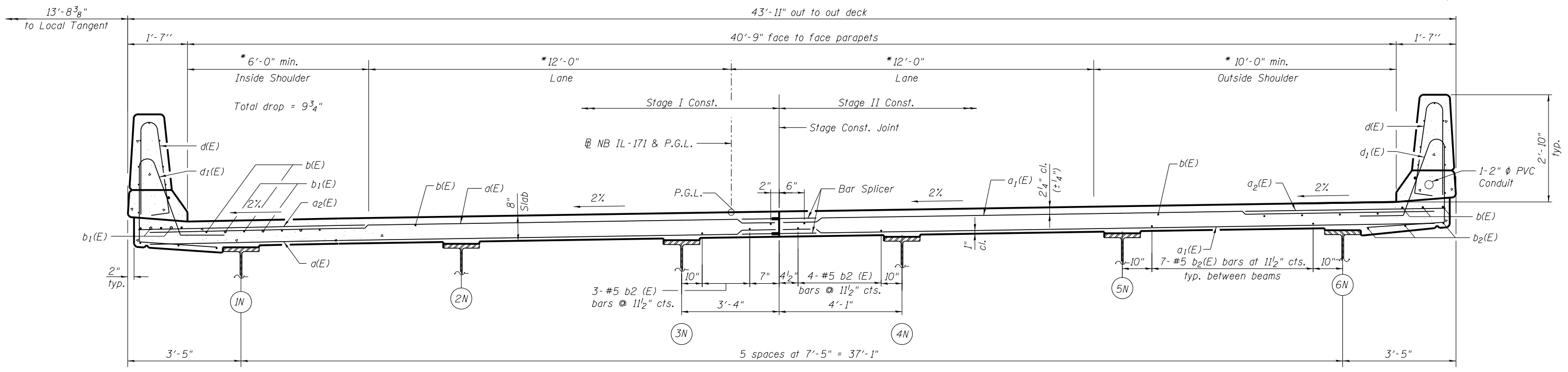

**CROSS SECTION - SN 016-1001**  
(Looking North)

**benesch**  
engineers · scientists · planners

Alfred Benesch & Company  
205 North Michigan Avenue, Suite 2400  
Chicago, Illinois 60601  
312-565-0450 Job No. 10093

|                                   |                     |                |           |
|-----------------------------------|---------------------|----------------|-----------|
| FILE NAME =                       | USER NAME = jsurber | DESIGNED - JOB | REVISED - |
| 0161000_60J16_016_superstr_NB.dgn |                     | CHECKED - RMM  | REVISED - |
|                                   |                     | DRAWN - MAK    | REVISED - |
|                                   |                     | CHECKED - RMM  | REVISED - |
|                                   |                     |                |           |

**STATE OF ILLINOIS**  
**DEPARTMENT OF TRANSPORTATION**

**SUPERSTRUCTURE**  
**STRUCTURE NO. 016-1000/1001**

SHEET NO. SA16 OF SA40 SHEETS

| F.A.P. RTE.               | SECTION     | COUNTY | TOTAL SHEETS | SHEET NO. |
|---------------------------|-------------|--------|--------------|-----------|
| 372                       | 2013-038B-R | COOK   | 821          | 264       |
| CONTRACT NO. 60J16        |             |        |              |           |
| ILLINOIS FED. AID PROJECT |             |        |              |           |

X:\100005\10093\Eng\_Docs\_Phase\_1\SN\_016\_1000\_1001\_1st\_Ave\_over\_47th\_St\_Final\0161000\_60J16\_016\_superstr\_NB.dgn

9:40:48 AM 7/29/2014

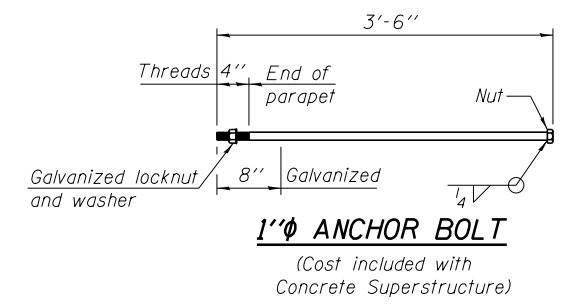
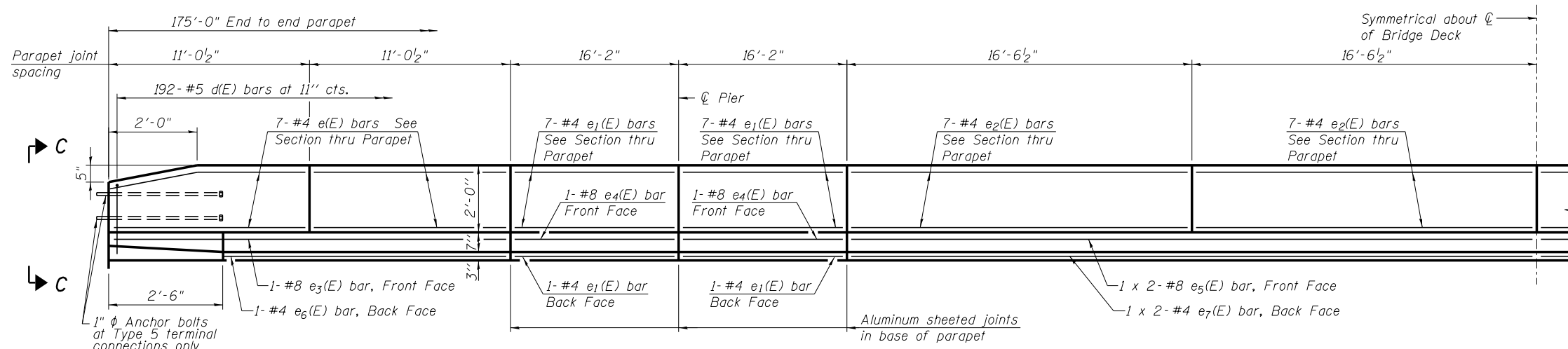

**INSIDE ELEVATION OF PARAPET - SN 016-1001**

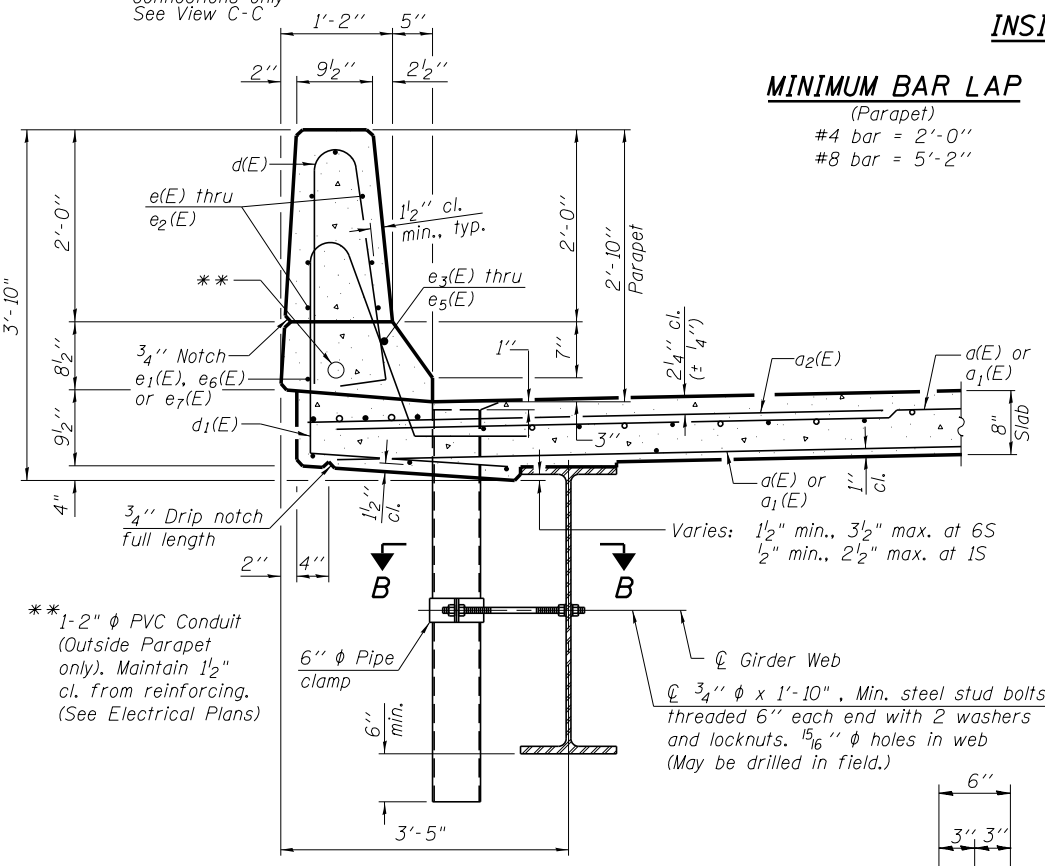

**MINIMUM BAR LAP**  
(Parapet)  
#4 bar = 2'-0"  
#8 bar = 5'-2"

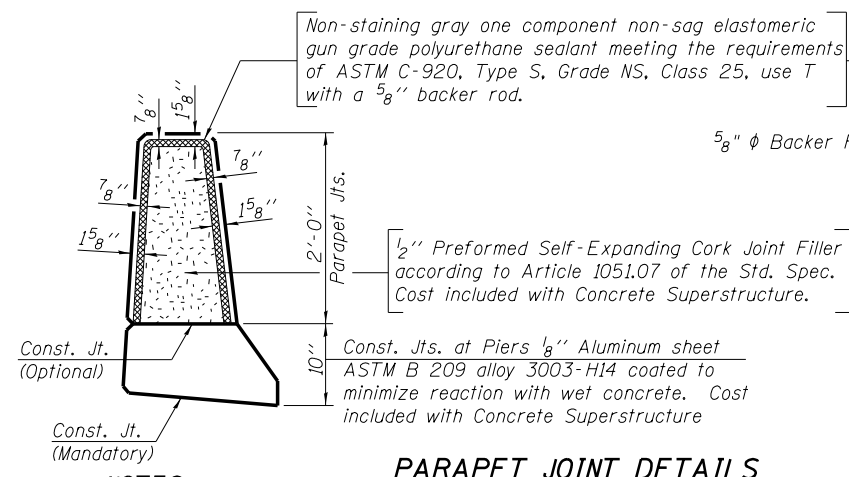

**NOTES:**

1. Drains shall be located clear of all diaphragms.
2. The exterior surfaces of the floor drains shall be painted with the finish coat as specified in Section 506 of the Standard Specifications. The exterior surfaces of the drains shall be cleaned according to the Society of Protective Coatings Spec. SSPC-SP1 prior to painting.
3. Fiberglass pipe shall conform to ASTM D 2996, with short-time rupture strength hoop tensile stress of 30,000 p.s.i. minimum.
4. Galvanize clamping device according to AASHTO M232. Cost of clamping device and inserts is included with Floor Drains.

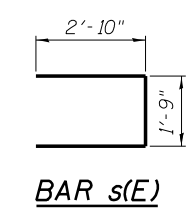
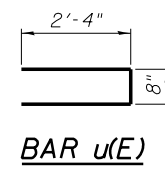
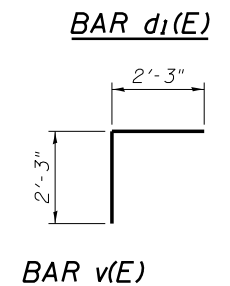
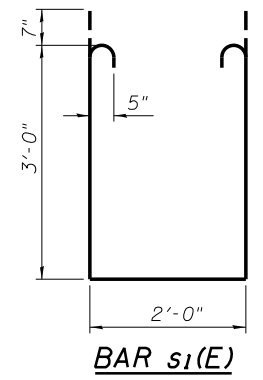
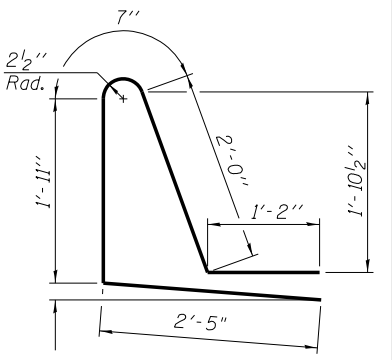
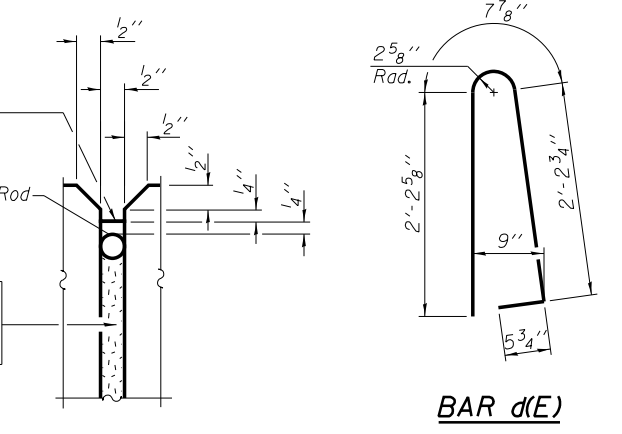
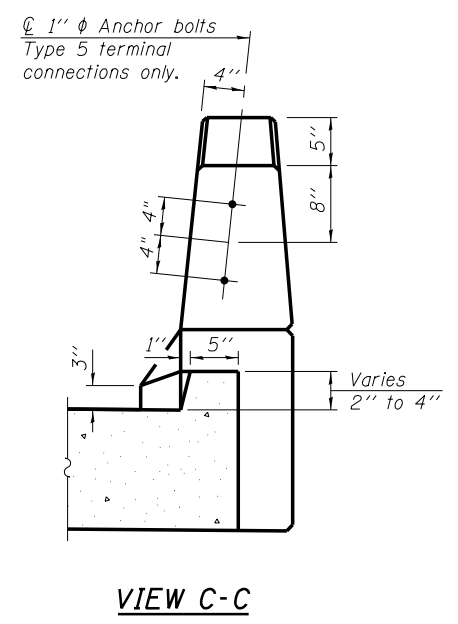
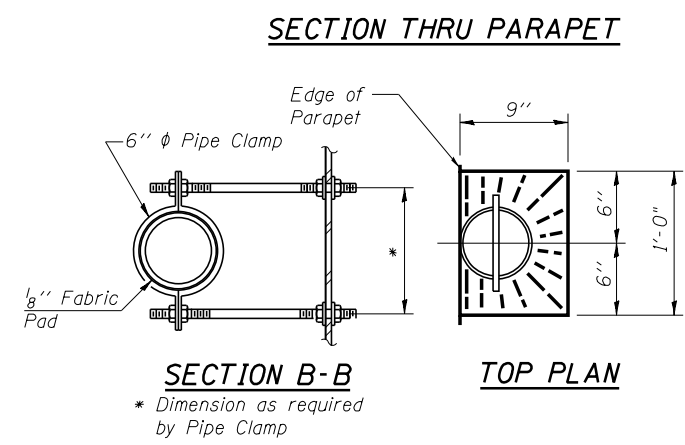

**SUPERSTRUCTURE BILL OF MATERIAL**

| Bar                              | No. | Size    | Length  | Shape |
|----------------------------------|-----|---------|---------|-------|
| d(E)                             | 616 | #5      | 21'-3"  | —     |
| a1(E)                            | 616 | #5      | 22'-0"  | —     |
| a2(E)                            | 764 | #6      | 6'-6"   | —     |
| b(E)                             | 288 | #5      | 31'-10" | —     |
| b1(E)                            | 88  | #6      | 57'-1"  | —     |
| b2(E)                            | 287 | #5      | 27'-9"  | —     |
| d(E)                             | 192 | #5      | 5'-7"   | ┌     |
| d1(E)                            | 192 | #5      | 8'-1"   | ┌     |
| m(E)                             | 24  | #5      | 4'-0"   | —     |
| m1(E)                            | 16  | #6      | 3'-0"   | —     |
| m2(E)                            | 32  | #6      | 7'-0"   | —     |
| m3(E)                            | 16  | #6      | 21'-10" | —     |
| m4(E)                            | 16  | #6      | 21'-1"  | —     |
| m5(E)                            | 8   | #6      | 2'-11"  | —     |
| m6(E)                            | 8   | #6      | 3'-8"   | —     |
| s(E)                             | 98  | #5      | 7'-5"   | ┌     |
| s1(E)                            | 84  | #5      | 9'-2"   | ┌     |
| u(E)                             | 98  | #5      | 5'-4"   | ┌     |
| e(E)                             | 56  | #4      | 10'-8"  | —     |
| e1(E)                            | 64  | #4      | 15'-10" | —     |
| e2(E)                            | 56  | #4      | 16'-2"  | —     |
| e3(E)                            | 4   | #8      | 21'-9"  | —     |
| e4(E)                            | 8   | #8      | 15'-10" | —     |
| e5(E)                            | 4   | #8      | 35'-6"  | —     |
| e6(E)                            | 4   | #4      | 21'-9"  | —     |
| e7(E)                            | 4   | #4      | 33'-11" | —     |
| v(E)                             | 92  | #5      | 4'-6"   | ┌     |
| Reinforcement Bars, Epoxy Coated |     | Pound   | 70335   |       |
| Concrete Superstructure          |     | Cu. Yd. | 242.6   |       |
| Floor Drains                     |     | Each    | 4       |       |
| Bridge Deck Grooving             |     | Sq. Yd. | 801     |       |
| Protective Coat                  |     | Sq. Yd. | 1038    |       |

Bars indicated thus 1 x 2-#8 etc. indicates 1 line of bars with 2 lengths per line.

|  |                      |                |             |
|--|----------------------|----------------|-------------|
| FILE NAME = 0161000.60J16.017.superstrdet.NB.dgn | USER NAME = tjenicke | DESIGNED - JOB | REVISIONS - |
|  |                      | CHECKED - RMM  | REVISIONS - |
|  |                      | DRAWN - MAK    | REVISIONS - |
|  |                      | CHECKED - RMM  | REVISIONS - |
|  |                      |                | REVISIONS - |

|                    |                       |               |                           |                 |
|--------------------|-----------------------|---------------|---------------------------|-----------------|
| F.A.P. RT. = 372   | SECTION = 2013-038B-R | COUNTY = COOK | TOTAL SHEETS = 821        | SHEET NO. = 265 |
| CONTRACT NO. 60J16 |                       |               | ILLINOIS FED. AID PROJECT |                 |

X:\1000005\100093\Eng\_Docs\_Phase\_1\11\SN\_016-1000-1001-1st-Ave-over-47th-St\Final\0161000-60J16-017.superstrdet.NB.dgn 2/28/06 PM 6/23/2014

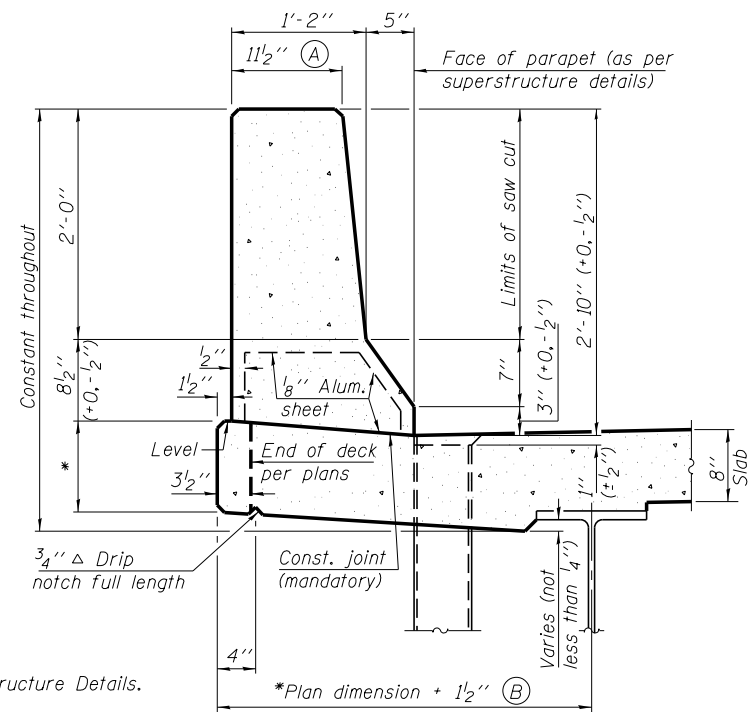

\*See Superstructure Details.

**34" F SHAPE PARAPET SECTION**  
(Showing dimensions)

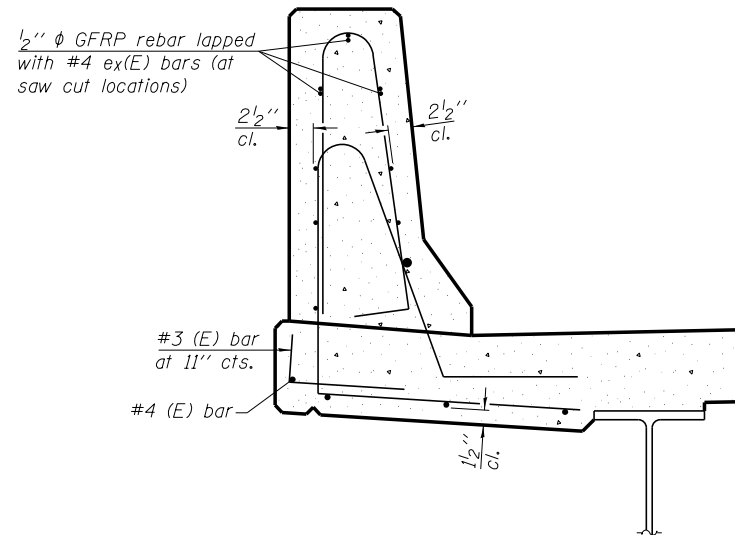

**SECTION**

(34" parapet shown - 42" parapet similar)  
(Showing reinforcement clearances for slip forming and additional reinforcement bars)

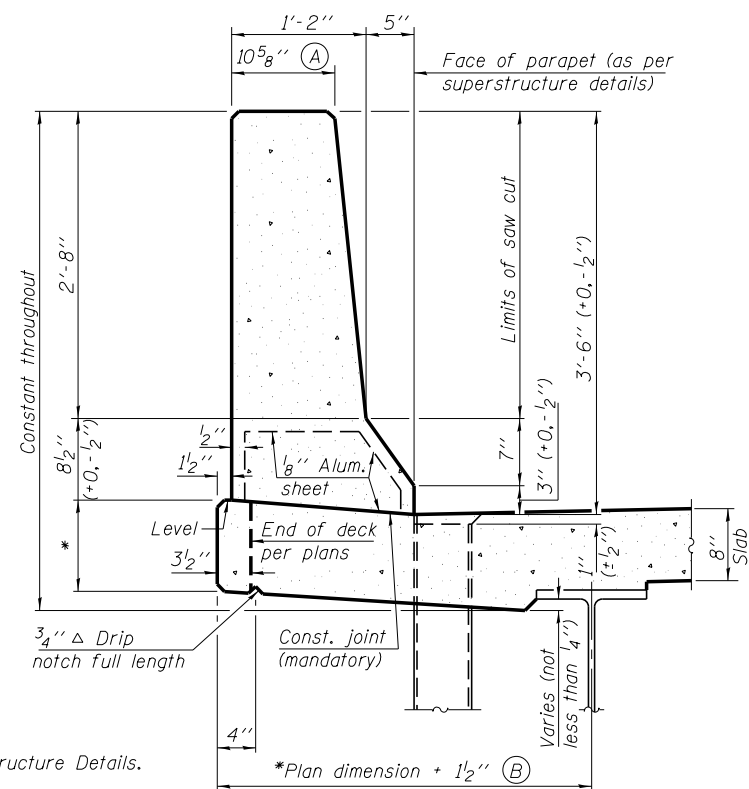

\*See Superstructure Details.

**42" F SHAPE PARAPET SECTION**  
(Showing dimensions)

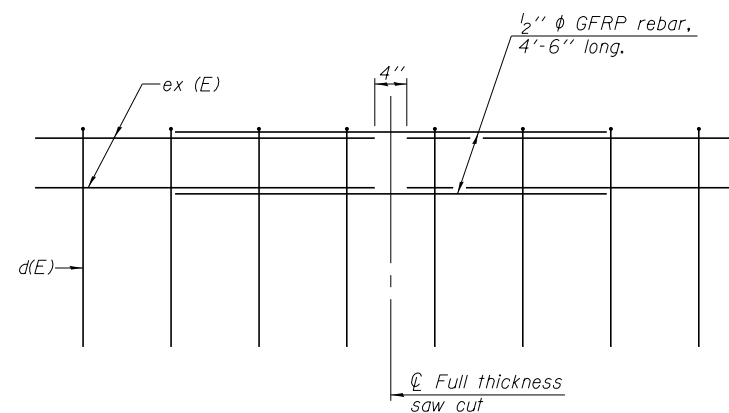

**GFRP REBAR STIFFENING DETAIL**

(Place as shown in parapet section at each parapet joint location.)

**GENERAL NOTES**

All dimensions shall remain the same as shown on superstructure details, except dimensions A and B which are to be revised as shown to provide additional clearance. Additional concrete needed to revise dimension A and B = 0.0165 cu. yds./ft. for 34" parapet or = 0.0223 cu. yds./ft. for 42" parapet. Place aluminum sheet in curb portion at and near piers. Full thickness saw cut at all joint locations in lieu of cork joint filler. Steel superstructure shown. Other superstructure types similar.

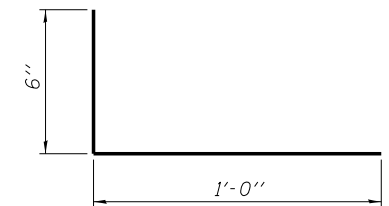

**#3 (E) BAR**

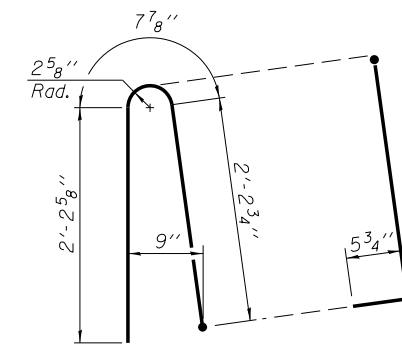

**ALTERNATE BAR d(E)**  
(For 34" parapet when conduit is present)

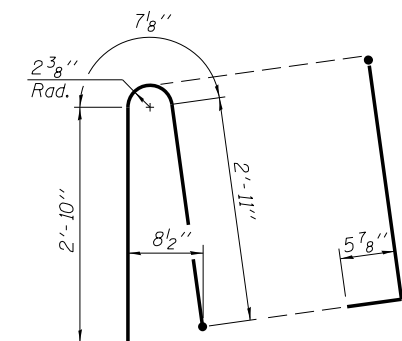

**ALTERNATE BAR d(E)**  
(For 42" parapet when conduit is present)



Alfred Benesch & Company  
205 North Michigan Avenue, Suite 2400  
Chicago, Illinois 60601  
312-565-0450 Job No. 10093

SFP 34-42

8-16-12

FILE NAME =  
0161000\_60J16\_018\_concs1pform.dgn

USER NAME = tjenicke  
PLOT SCALE =  
PLOT DATE = 12/20/2012

|                |           |
|----------------|-----------|
| DESIGNED - MAK | REVISED - |
| CHECKED - RMM  | REVISED - |
| DRAWN - MAK    | REVISED - |
| CHECKED - RMM  | REVISED - |

**STATE OF ILLINOIS  
DEPARTMENT OF TRANSPORTATION**

**CONCRETE PARAPET SLIPFORMING OPTION  
STRUCTURE NO. 016-1000/1001**

SHEET NO. SA18 OF SA40 SHEETS

| F.A.P. RE.                | SECTION     | COUNTY | TOTAL SHEETS | SHEET NO.          |
|---------------------------|-------------|--------|--------------|--------------------|
| 372                       | 2013-038B-R | COOK   | 821          | 266                |
|                           |             |        |              | CONTRACT NO. 60J16 |
| ILLINOIS FED. AID PROJECT |             |        |              |                    |

X:\1000005\100093\Eng\_Docs\_Phase\_1\1\SN\_016\_1000\_1001\_1st\_Ave\_over\_47th\_St\Final\0161000\_60J16\_018\_concs1pform.dgn 2:28:07 PM 6/23/2014

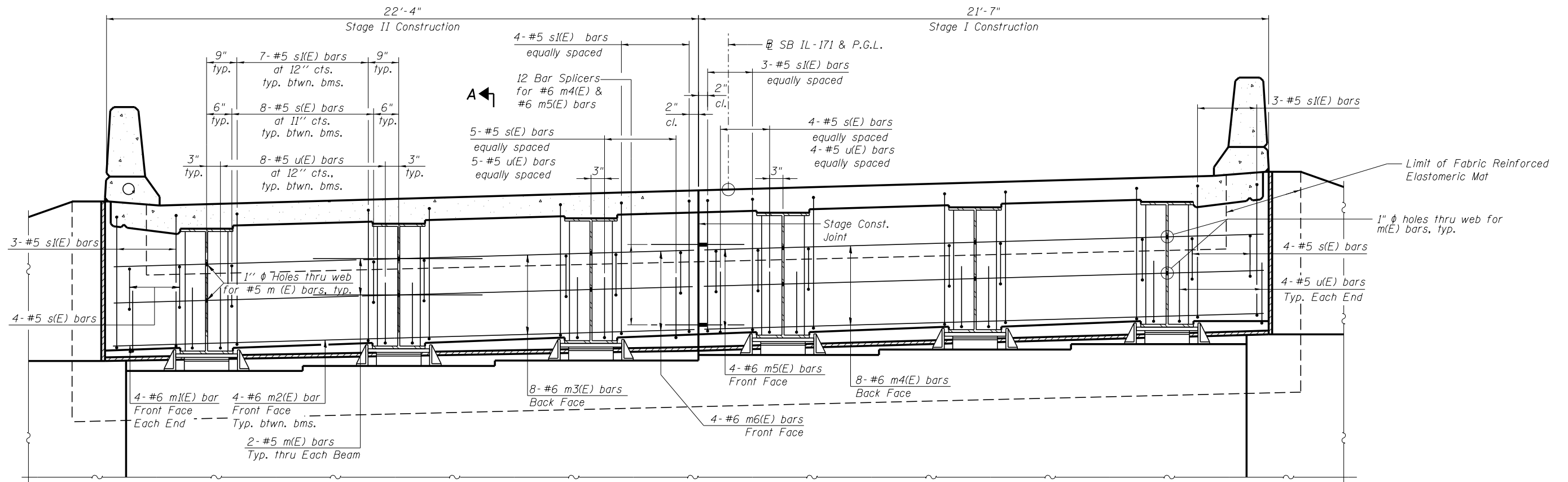

**DIAPHRAGM ELEVATION AT ABUTMENT - SN 016-1000**  
 (SB N. Abutment shown looking North - SB S. Abutment opposite hand)

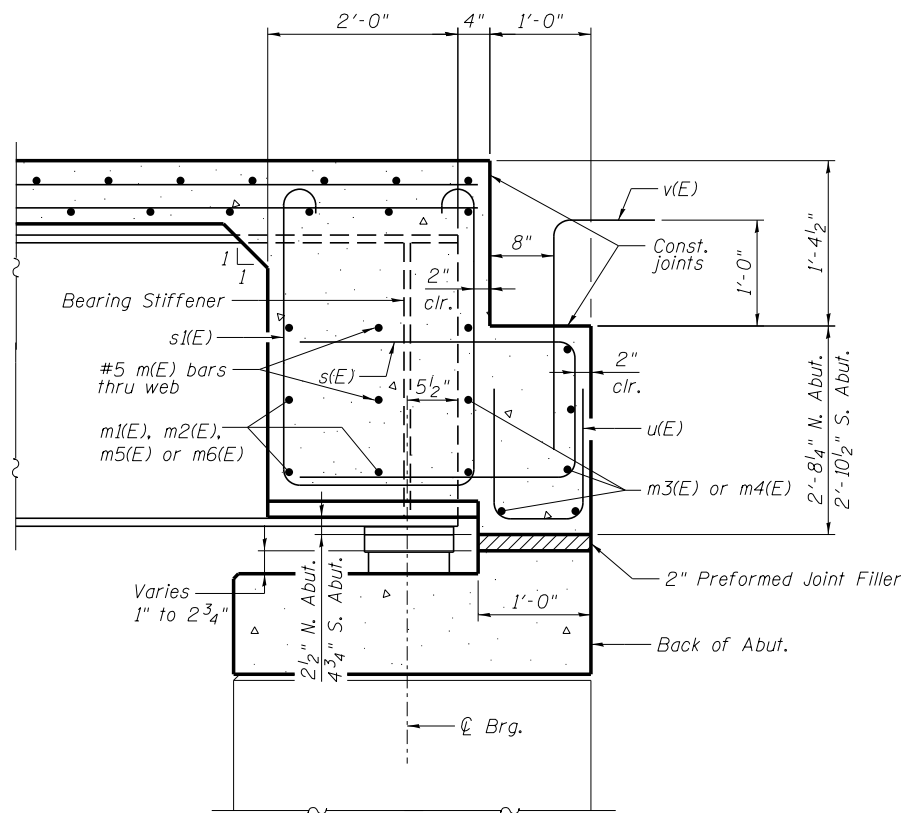

**SECTION A-A**

**MIN. BAR LAP**  
 #6 bar = 3'-6"

**NOTES:**

1. Reinforcement bars in diaphragm are billed with superstructure on sheet SA15.
2. Concrete in diaphragm is included with Concrete Superstructure on sheet SA15.
3. For details of bars s(E) & s1(E) see sheet SA15.
4. For details of bars v(E), see sheets SA14 & SA15.
5. For Bar Splicer Details, see sheet SA40.
6. For Bearing Details, see sheet SA28.

**benesch**  
 engineers · scientists · planners  
 Alfred Benesch & Company  
 205 North Michigan Avenue, Suite 2400  
 Chicago, Illinois 60601  
 312-565-0450 Job No. 10093

|                                       |                        |                |           |
|---------------------------------------|------------------------|----------------|-----------|
| FILE NAME =                           | USER NAME = jsurber    | DESIGNED - DJM | REVISED - |
| 0161000_60J16_019_abutdiaphdet_SB.dgn |                        | CHECKED - RMM  | REVISED - |
|                                       | PLOT SCALE =           | DRAWN - MAK    | REVISED - |
|                                       | PLOT DATE = 12/20/2012 | CHECKED - RMM  | REVISED - |

**STATE OF ILLINOIS  
 DEPARTMENT OF TRANSPORTATION**

**SEMI-INTEGRAL ABUTMENT DIAPHRAGM DETAILS  
 STRUCTURE NO. 016-1000/1001**

| F.A.P. RTE.               | SECTION     | COUNTY | TOTAL SHEETS       | SHEET NO. |
|---------------------------|-------------|--------|--------------------|-----------|
| 372                       | 2013-038B-R | COOK   | 821                | 267       |
|                           |             |        | CONTRACT NO. 60J16 |           |
| ILLINOIS FED. AID PROJECT |             |        |                    |           |

SHEET NO. SA19 OF SA40 SHEETS

X:\1000005\10093\Eng\_Docs\_Phase\_1\SN\_016\_1000\_1001\_1st\_Ave\_over\_47th\_St\Final\0161000\_60J16\_019\_abutdiaphdet\_SB.dgn  
 9:40:50 AM  
 7/29/2014

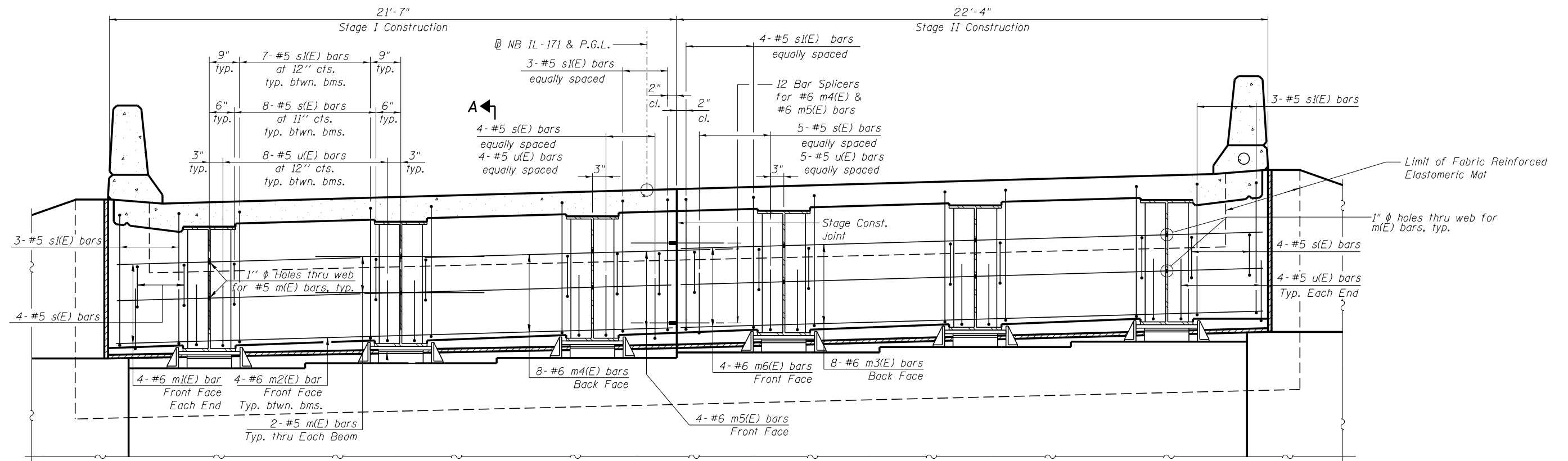

**DIAPHRAGM ELEVATION AT ABUTMENT - SN 016-1001**  
 (NB N. Abutment shown looking North - NB S. Abutment opposite hand)

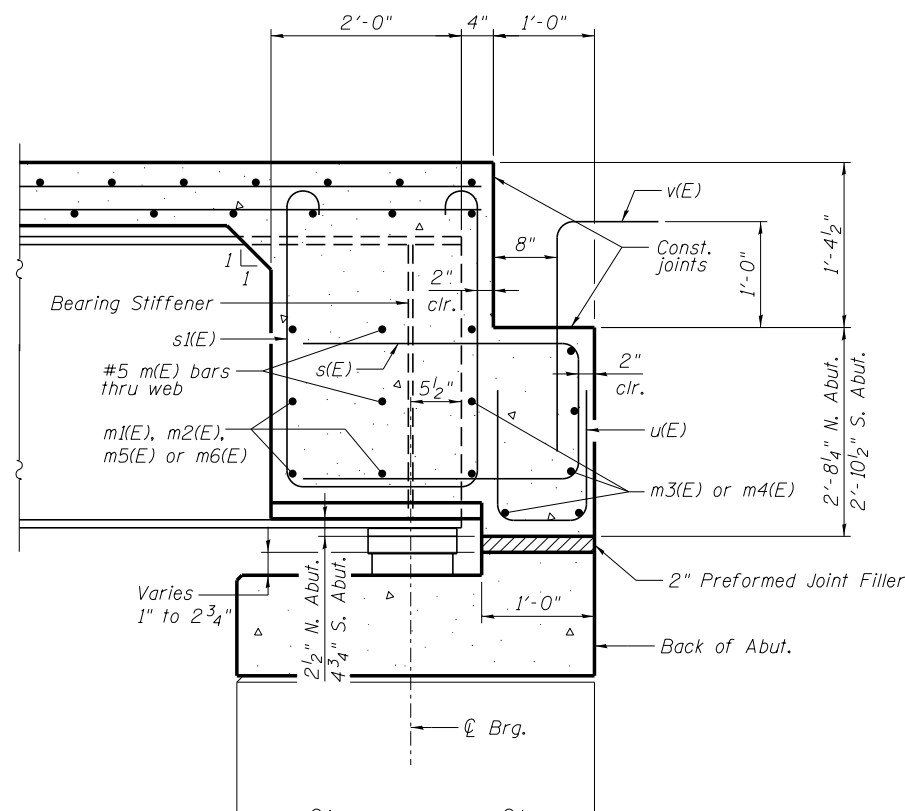

**SECTION A-A**

**MIN. BAR LAP**  
 #6 bar = 3'-6"

**NOTES:**

1. Reinforcement bars in diaphragm are billed with superstructure on sheet SA17.
2. Concrete in diaphragm is included with Concrete Superstructure on sheet SA17.
3. For details of bars s(E) & s(E) see sheet SA17.
4. For details of bars v(E), see sheets SA16 & SA17.
5. For Bar Splicer Details, see sheet SA40.
6. For Bearing Details, see sheet SA28.

**benesch**  
 engineers · scientists · planners

Alfred Benesch & Company  
 205 North Michigan Avenue, Suite 2400  
 Chicago, Illinois 60601  
 312-565-0450 Job No. 10093

|                                       |                        |                |           |
|---------------------------------------|------------------------|----------------|-----------|
| FILE NAME =                           | USER NAME = jsurber    | DESIGNED - DJM | REVISED - |
|                                       |                        | CHECKED - RMM  | REVISED - |
| 0161000_60J16_020_abutdiaphdet.NB.dgn | PLOT SCALE =           | DRAWN - MAK    | REVISED - |
|                                       | PLOT DATE = 12/20/2012 | CHECKED - RMM  | REVISED - |

**STATE OF ILLINOIS  
 DEPARTMENT OF TRANSPORTATION**

**SEMI-INTEGRAL ABUTMENT DIAPHRAGM DETAILS  
 STRUCTURE NO. 016-1000/1001**

| F.A.P. RTE.               | SECTION     | COUNTY | TOTAL SHEETS | SHEET NO. |
|---------------------------|-------------|--------|--------------|-----------|
| 372                       | 2013-038B-R | COOK   | 821          | 268       |
| CONTRACT NO. 60J16        |             |        |              |           |
| ILLINOIS FED. AID PROJECT |             |        |              |           |

SHEET NO. SA20 OF SA40 SHEETS



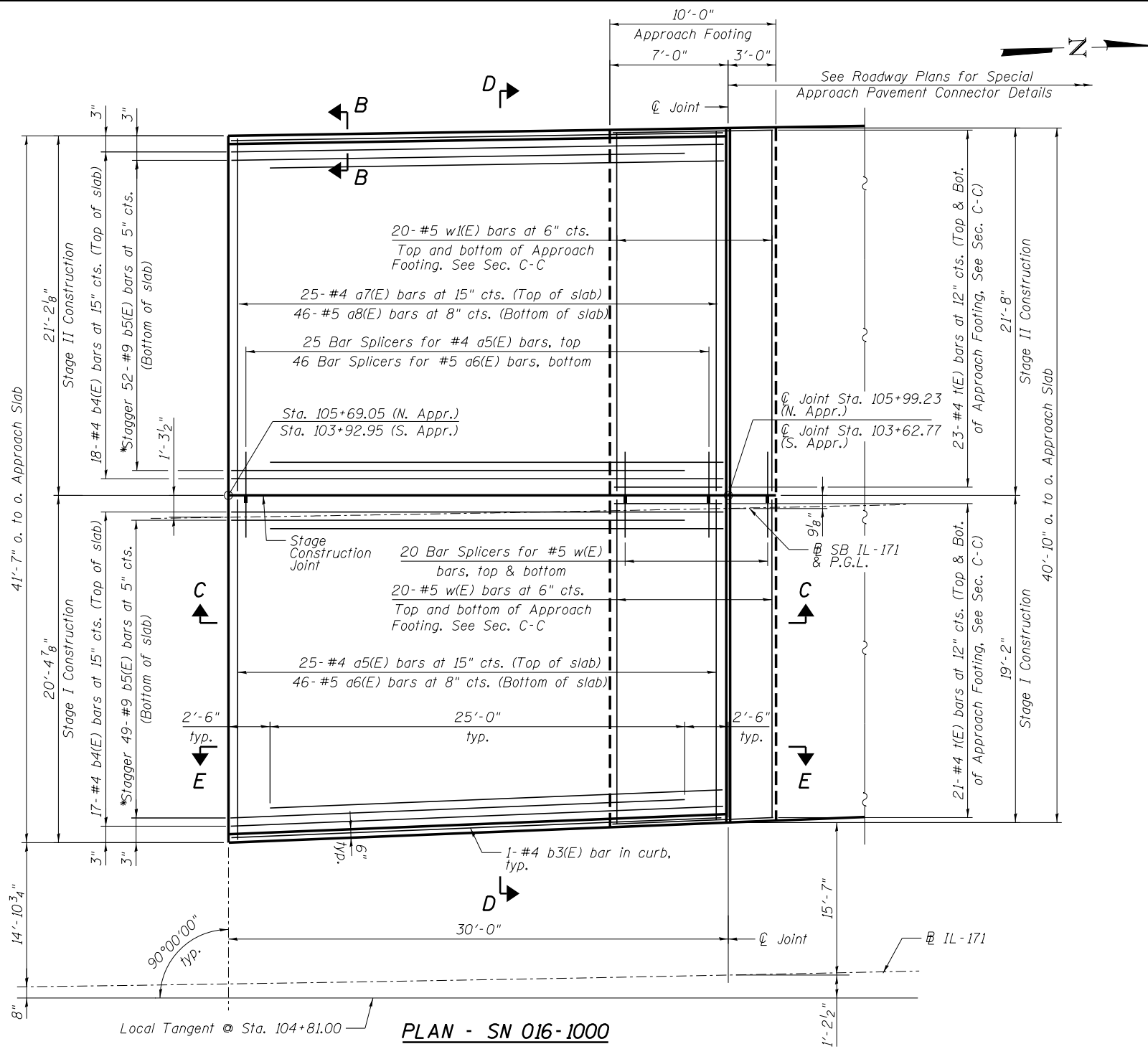

**PLAN - SN 016-1000**  
 (SB North Approach shown, SB South Approach similar and opposite hand)

\* Tilt #9 b5(E) bars as required to maintain clearance.

\*\* Cost included with Concrete Superstructure.

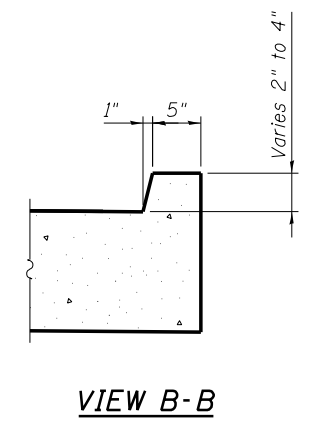
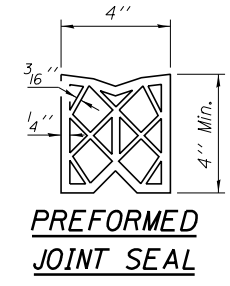
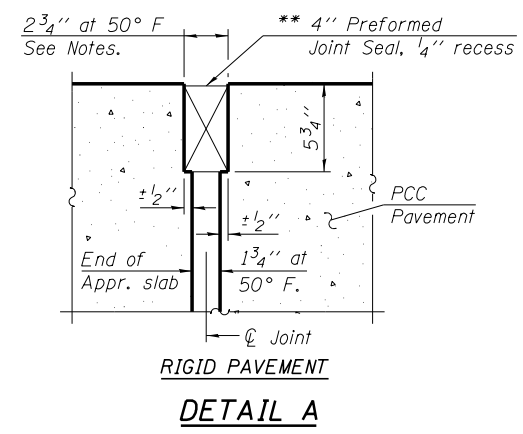

**NOTES:**

1. See sheet SA22 for Sections C-C & D-D and View E-E.
2. ax(E) bar spacings measured along  $\text{\textcircled{C}}$  Rdwy.
3. The joint opening shall be determined per Article 520.04 except that on jointless structures, the distance described as the bridge length between the nearest fixed bearings each way from the joint shall be taken as half the bridge length plus the approach slab length. The minimum dimension shall be 1 1/2" for installation purposes.

**benesch**  
 engineers · scientists · planners  
 Alfred Benesch & Company  
 205 North Michigan Avenue, Suite 2400  
 Chicago, Illinois 60601  
 312-565-0450 Job No. 10093

|                                       |                        |                |           |
|---------------------------------------|------------------------|----------------|-----------|
| FILE NAME =                           | USER NAME = jsurber    | DESIGNED - JOB | REVISED - |
| 0161000.60J16.021.appslabdet-1.SB.dgn |                        | CHECKED - RMM  | REVISED - |
|                                       | PLOT SCALE =           | DRAWN - MAK    | REVISED - |
|                                       | PLOT DATE = 12/20/2012 | CHECKED - RMM  | REVISED - |

**STATE OF ILLINOIS  
 DEPARTMENT OF TRANSPORTATION**

**BRIDGE APPROACH SLAB DETAILS (1 OF 2)  
 STRUCTURE NO. 016-1000/1001**

| F.A.P. RTE.               | SECTION     | COUNTY | TOTAL SHEETS | SHEET NO. |
|---------------------------|-------------|--------|--------------|-----------|
| 372                       | 2013-038B-R | COOK   | 821          | 269       |
| CONTRACT NO. 60J16        |             |        |              |           |
| ILLINOIS FED. AID PROJECT |             |        |              |           |

SHEET NO. SA21 OF SA40 SHEETS

X:\1000005\100093\Eng\_Docs\_Phase\_1\11\SN\_016\_1000\_1001\_1st\_Ave\_over\_47th\_St\Final\0161000\_60J16\_021.appslabdet-1.SB.dgn 9:40:52 AM 7/29/2014

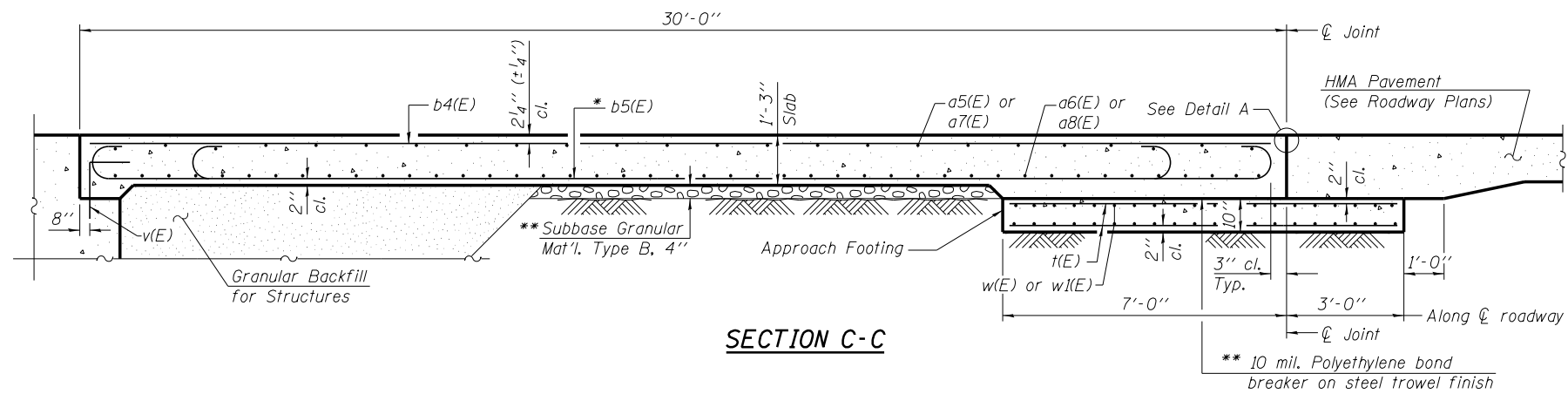

**NOTES:**

1. See sheet SA21 for Detail A and View B-B.
2. Approach slab concrete shall be paid for as Concrete Superstructure.
3. Approach footing concrete shall be paid for as Concrete Structures.
4. Reinforcement shall be paid for as Reinforcement Bars, Epoxy Coated.
5. For v(E) bar details, see sheet SA15.
6. The approach footing maximum applied service bearing pressure (Qmax) = 2.0 ksf.
7. For bar splicer details, see sheet SA40.
8. Cost of excavation for approach footing included with Concrete Structures.
9. For Granular Backfill for Structures and drainage treatment details, see sheet SA2.

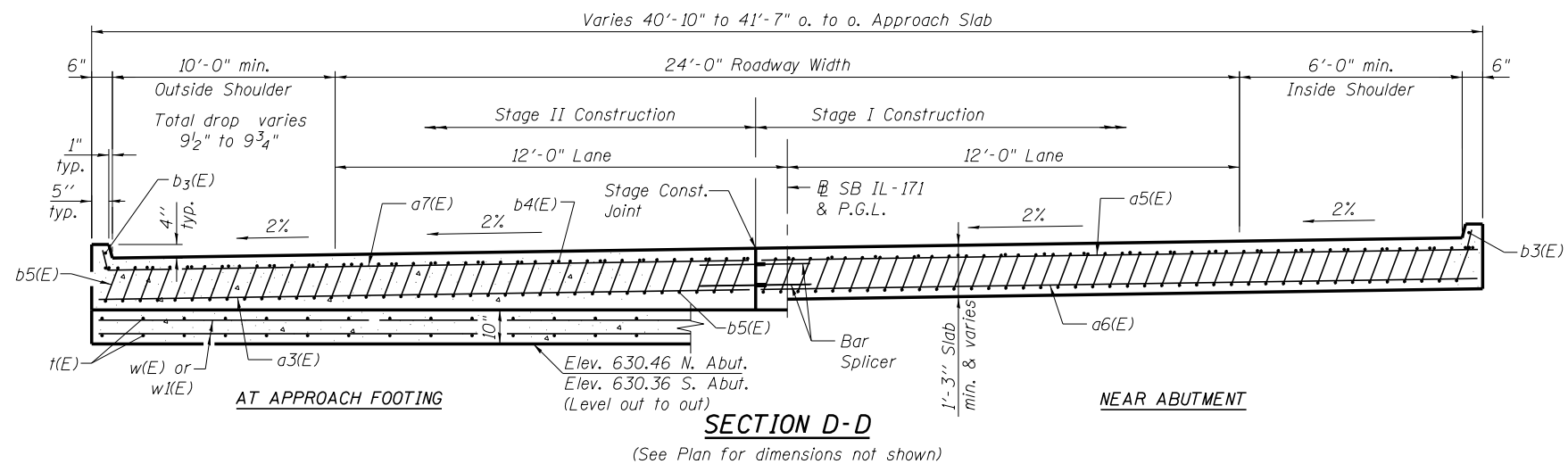

- \* Tilt #9 b5(E) bars as required to maintain clearance.
- \*\* Cost included with Concrete Superstructure.

**TWO APPROACHES  
BILL OF MATERIAL**

| Bar                              | No. | Size | Length  | Shape |
|----------------------------------|-----|------|---------|-------|
| a5(E)                            | 50  | #4   | 19'-4"  | ┌───┐ |
| a6(E)                            | 92  | #5   | 18'-11" | ┌───┐ |
| a7(E)                            | 50  | #4   | 21'-4"  | ┌───┐ |
| a8(E)                            | 92  | #5   | 20'-11" | ┌───┐ |
| b3(E)                            | 4   | #4   | 29'-8"  | ┌───┐ |
| b4(E)                            | 70  | #4   | 29'-8"  | ┌───┐ |
| b5(E)                            | 202 | #9   | 29'-8"  | ┌───┐ |
| t(E)                             | 176 | #4   | 9'-8"   | ┌───┐ |
| w(E)                             | 80  | #5   | 18'-11" | ┌───┐ |
| w1(E)                            | 80  | #5   | 20'-11" | ┌───┐ |
| Concrete Superstructure          |     |      | Cu. Yd. | 116.7 |
| Concrete Structures              |     |      | Cu. Yd. | 25.5  |
| Reinforcement Bars, Epoxy Coated |     |      | Pound   | 31610 |
| Bridge Deck Grooving             |     |      | Sq. Yd. | 270   |
| Protective Coat                  |     |      | Sq. Yd. | 352   |

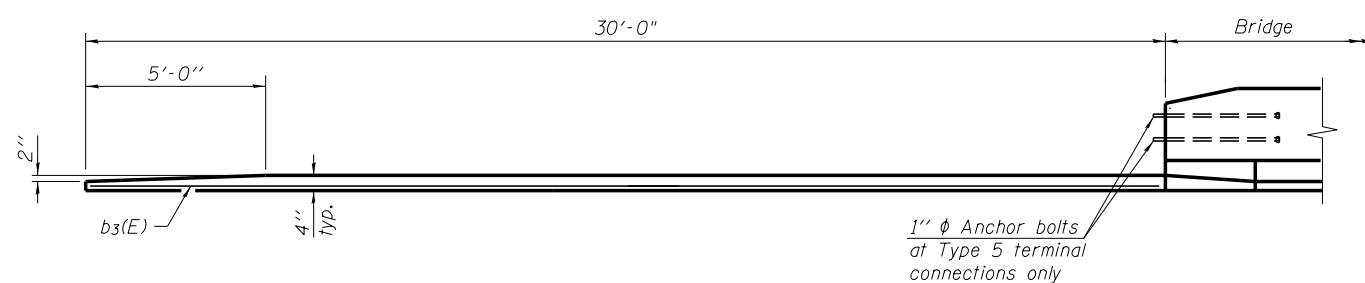

**VIEW E-E**

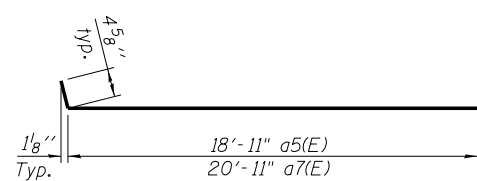

**BAR a5(E) & a7(E)**

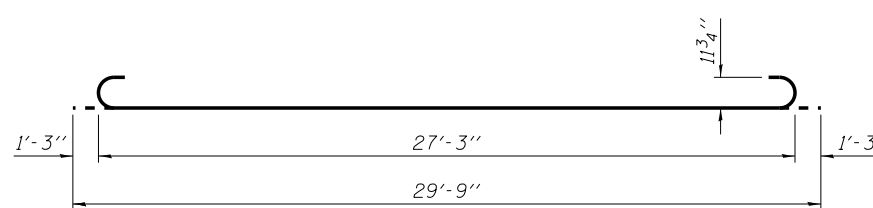

**BAR b5(E)**

**benesch**  
engineers · scientists · planners  
Alfred Benesch & Company  
205 North Michigan Avenue, Suite 2400  
Chicago, Illinois 60601  
312-565-0450 Job No. 10093

|                                       |                        |                |           |
|---------------------------------------|------------------------|----------------|-----------|
| FILE NAME =                           | USER NAME = tjenicke   | DESIGNED - JOB | REVISED - |
| 0161000_60J16_022_apps1abdet-2.SB.dgn |                        | CHECKED - RMM  | REVISED - |
|                                       | PLOT SCALE =           | DRAWN - MAK    | REVISED - |
|                                       | PLOT DATE = 12/20/2012 | CHECKED - RMM  | REVISED - |

**STATE OF ILLINOIS  
DEPARTMENT OF TRANSPORTATION**

**BRIDGE APPROACH SLAB DETAILS (2 OF 2)  
STRUCTURE NO. 016-1000/1001**

SHEET NO. SA22 OF SA40 SHEETS

|                           |             |        |                    |           |
|---------------------------|-------------|--------|--------------------|-----------|
| F.A.P. RTE.               | SECTION     | COUNTY | TOTAL SHEETS       | SHEET NO. |
| 372                       | 2013-038B-R | COOK   | 821                | 270       |
|                           |             |        | CONTRACT NO. 60J16 |           |
| ILLINOIS FED. AID PROJECT |             |        |                    |           |

X:\1000005\100093\Eng\_Docs\_Phase\_1\1001\_1st\_Ave\_over\_47th\_St\Final\0161000\_60J16\_022\_apps1abdet-2.SB.dgn 2:28:11 PM 6/23/2014

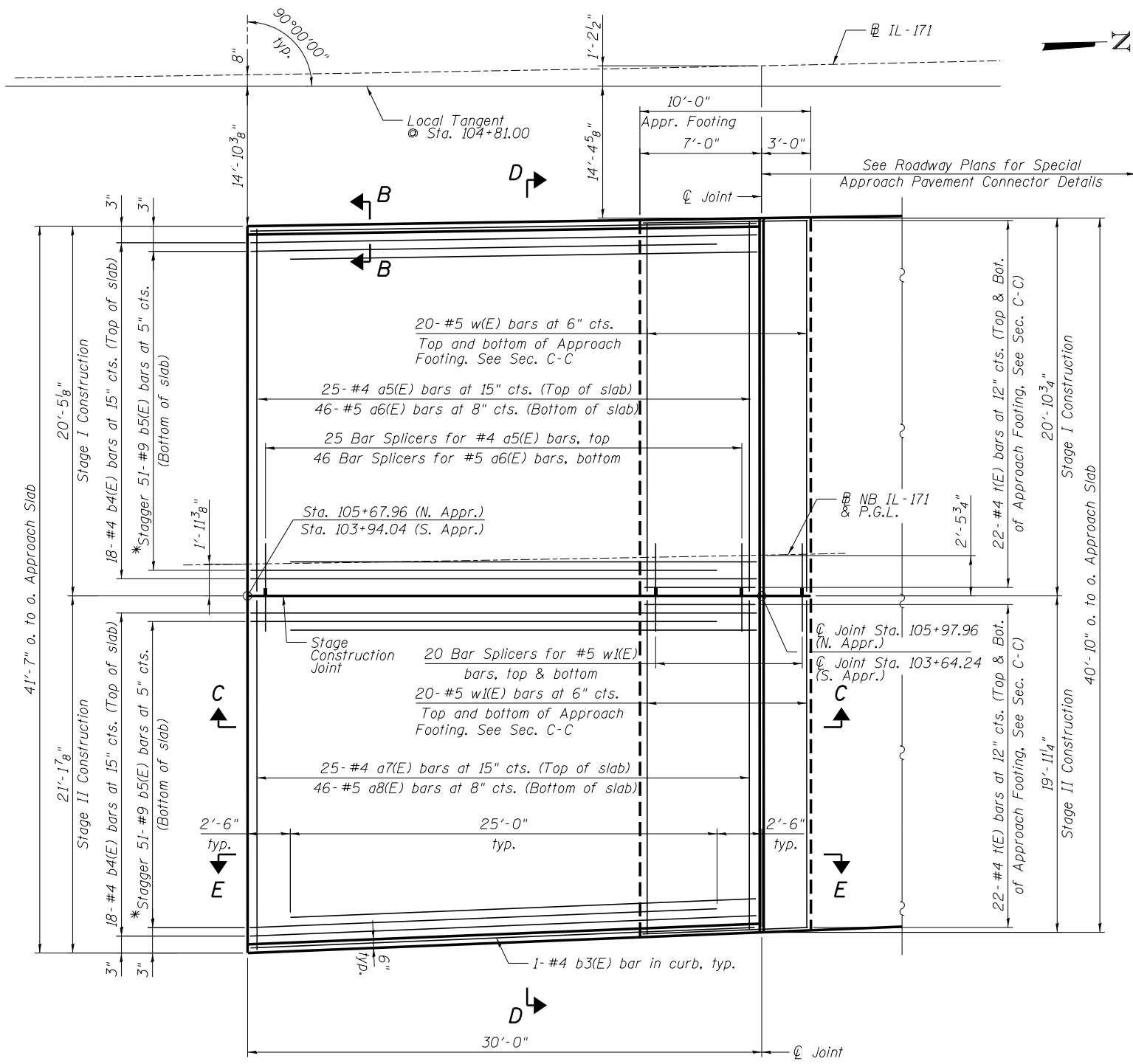

**PLAN - SN 016-1001**

(NB North Approach shown, NB South Approach similar and opposite hand)

\*Tilt #9 b5(E) bars as required to maintain clearance.

\*\* Cost included with Concrete Superstructure.

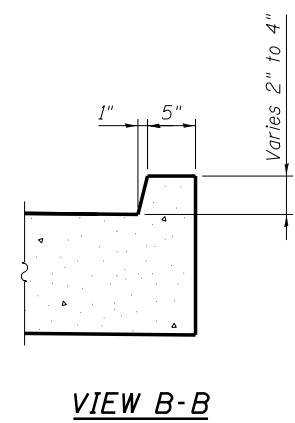
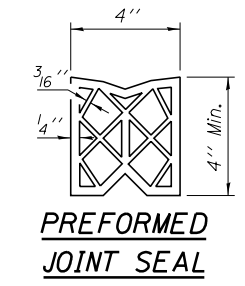
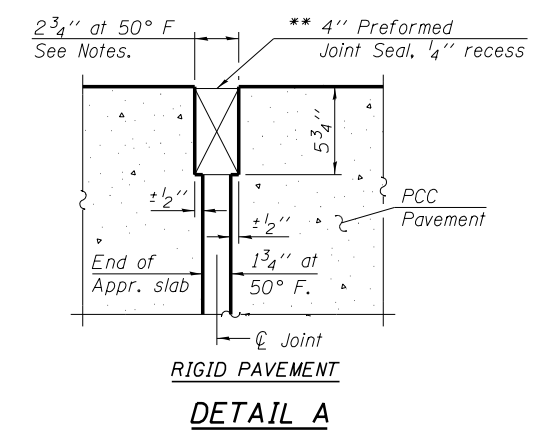

**NOTES:**

1. See sheet SA24 for Sections C-C & D-D and View E-E.
2. ax(E) bar spacings measured along  $\mathcal{C}$  Rdwy.
3. The joint opening shall be determined per Article 520.04 except that on jointless structures, the distance described as the bridge length between the nearest fixed bearings each way from the joint shall be taken as half the bridge length plus the approach slab length. The minimum dimension shall be 1 1/2" for installation purposes.

**benesch**  
engineers · scientists · planners

Alfred Benesch & Company  
205 North Michigan Avenue, Suite 2400  
Chicago, Illinois 60601  
312-565-0450 Job No. 10093

|                                       |                        |                |           |
|---------------------------------------|------------------------|----------------|-----------|
| FILE NAME =                           | USER NAME = jsurber    | DESIGNED - JOB | REVISED - |
| 0161000_60J16_023.appslabdet-1.NB.dgn |                        | CHECKED - RMM  | REVISED - |
|                                       | PLOT SCALE =           | DRAWN - MAK    | REVISED - |
|                                       | PLOT DATE = 12/20/2012 | CHECKED - RMM  | REVISED - |

**STATE OF ILLINOIS  
DEPARTMENT OF TRANSPORTATION**

**BRIDGE APPROACH SLAB DETAILS (1 OF 2)  
STRUCTURE NO. 016-1000/1001**

| F.A.P. RTE.        | SECTION     | COUNTY | TOTAL SHEETS              | SHEET NO. |
|--------------------|-------------|--------|---------------------------|-----------|
| 372                | 2013-038B-R | COOK   | 821                       | 271       |
| CONTRACT NO. 60J16 |             |        | ILLINOIS FED. AID PROJECT |           |

SHEET NO. SA23 OF SA40 SHEETS

X:\1000005\100093\Eng\_Docs\_Phase\_1\1\SN\_016\_1000\_1001\_1st\_Ave\_over\_47th\_St\Final\0161000\_60J16\_023.appslabdet-1.NB.dgn 9:40:53 AM 7/29/2014

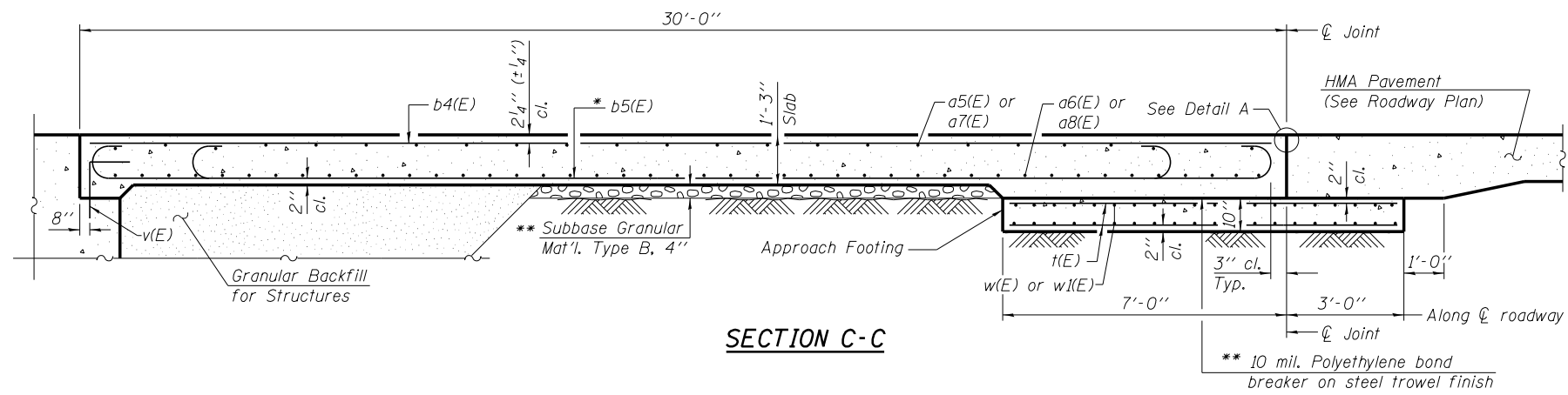

**NOTES:**

1. See sheet SA23 for Detail A and View B-B.
2. Approach slab concrete shall be paid for as Concrete Superstructure.
3. Approach footing concrete shall be paid for as Concrete Structures.
4. Reinforcement shall be paid for as Reinforcement Bars, Epoxy Coated.
5. For v(E) bar details, see sheet SA17.
6. The approach footing maximum applied service bearing pressure (Qmax) = 2.0 ksf.
7. For bar splicer details, see sheet SA40.
8. Cost of excavation for approach footing included with Concrete Structures.
9. For Granular Backfill for Structures and drainage treatment details, see sheet SA2.

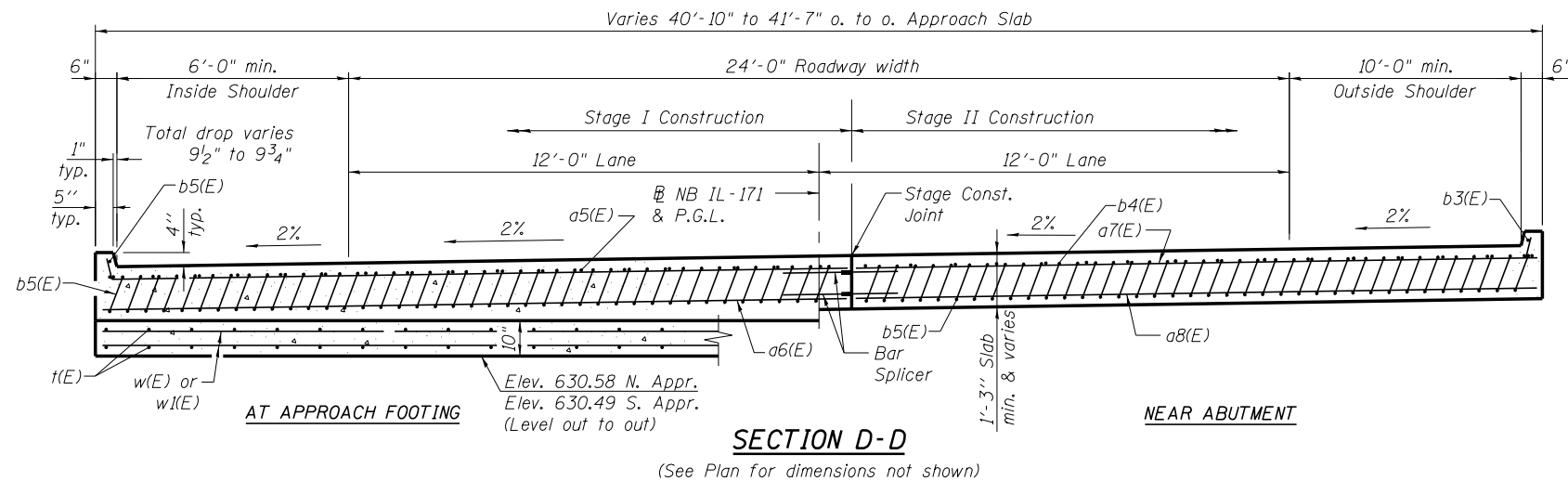

- \* Tilt #9 b5(E) bars as required to maintain clearance.
- \*\* Cost included with Concrete Superstructure.

**TWO APPROACHES  
BILL OF MATERIAL**

| Bar                              | No. | Size | Length  | Shape  |
|----------------------------------|-----|------|---------|--------|
| a5(E)                            | 50  | #4   | 20'-7"  | U      |
| a6(E)                            | 92  | #5   | 20'-2"  | U      |
| a7(E)                            | 50  | #4   | 20'-1"  | U      |
| a8(E)                            | 92  | #5   | 19'-8"  | U      |
| b3(E)                            | 4   | #4   | 29'-8"  | U      |
| b4(E)                            | 72  | #4   | 29'-8"  | U      |
| b5(E)                            | 204 | #9   | 29'-8"  | U      |
| t(E)                             | 176 | #4   | 9'-8"   | U      |
| w(E)                             | 80  | #5   | 20'-2"  | U      |
| w1(E)                            | 80  | #5   | 19'-8"  | U      |
| Concrete Superstructure          |     |      | Cu. Yd. | 116.7  |
| Concrete Structures              |     |      | Cu. Yd. | 25.5   |
| Reinforcement Bars, Epoxy Coated |     |      | Pound   | 316.10 |
| Bridge Deck Grooving             |     |      | Sq. Yd. | 270    |
| Protective Coat                  |     |      | Sq. Yd. | 352    |

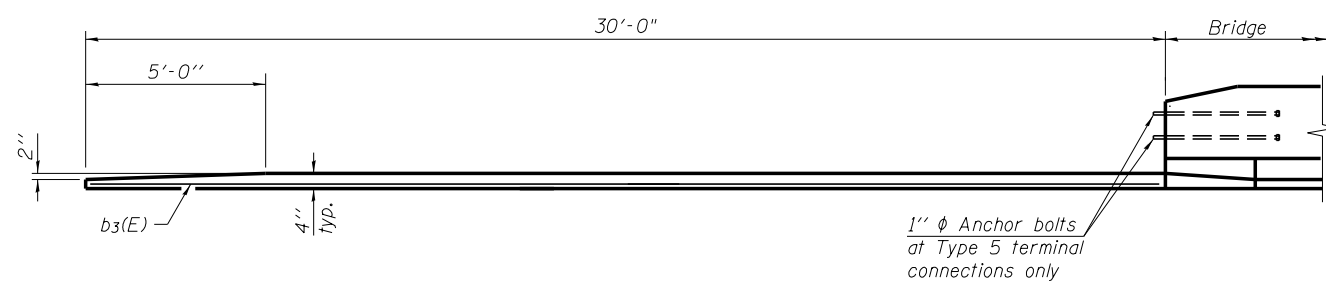

**VIEW E-E**

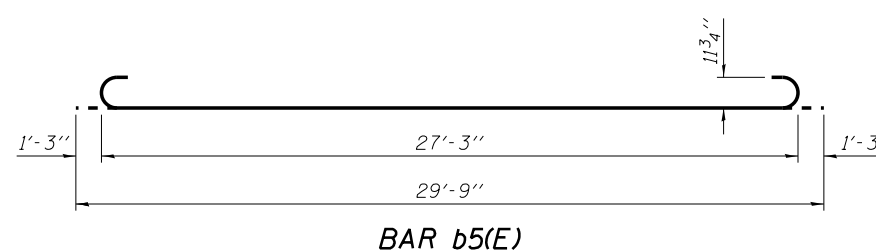
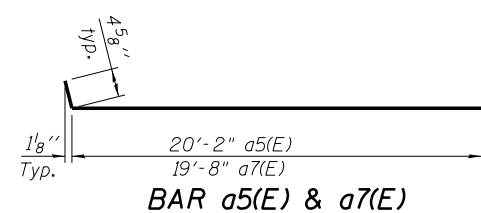

**benesch**  
engineers · scientists · planners

Alfred Benesch & Company  
205 North Michigan Avenue, Suite 2400  
Chicago, Illinois 60601  
312-565-0450 Job No. 10093

|                                       |                        |                |           |
|---------------------------------------|------------------------|----------------|-----------|
| FILE NAME =                           | USER NAME = tjenicke   | DESIGNED - JOB | REVISED - |
| 0161000_60J16_024_appslabdet-2.NB.dgn |                        | CHECKED - RMM  | REVISED - |
|                                       | PLOT SCALE =           | DRAWN - MAK    | REVISED - |
|                                       | PLOT DATE = 12/20/2012 | CHECKED - RMM  | REVISED - |

**STATE OF ILLINOIS  
DEPARTMENT OF TRANSPORTATION**

**BRIDGE APPROACH SLAB DETAILS (2 OF 2)  
STRUCTURE NO. 016-1000/1001**

SHEET NO. SA24 OF SA40 SHEETS

|                           |             |        |                    |           |
|---------------------------|-------------|--------|--------------------|-----------|
| F.A.P. RTE.               | SECTION     | COUNTY | TOTAL SHEETS       | SHEET NO. |
| 372                       | 2013-038B-R | COOK   | 821                | 272       |
|                           |             |        | CONTRACT NO. 60J16 |           |
| ILLINOIS FED. AID PROJECT |             |        |                    |           |

X:\1000005\100093\Eng\_Docs\_Phase\_1\1001\_1st\_Ave\_over\_47th\_St\Final\0161000\_60J16\_024\_appslabdet-2.NB.dgn 2:28:13 PM 6/23/2014

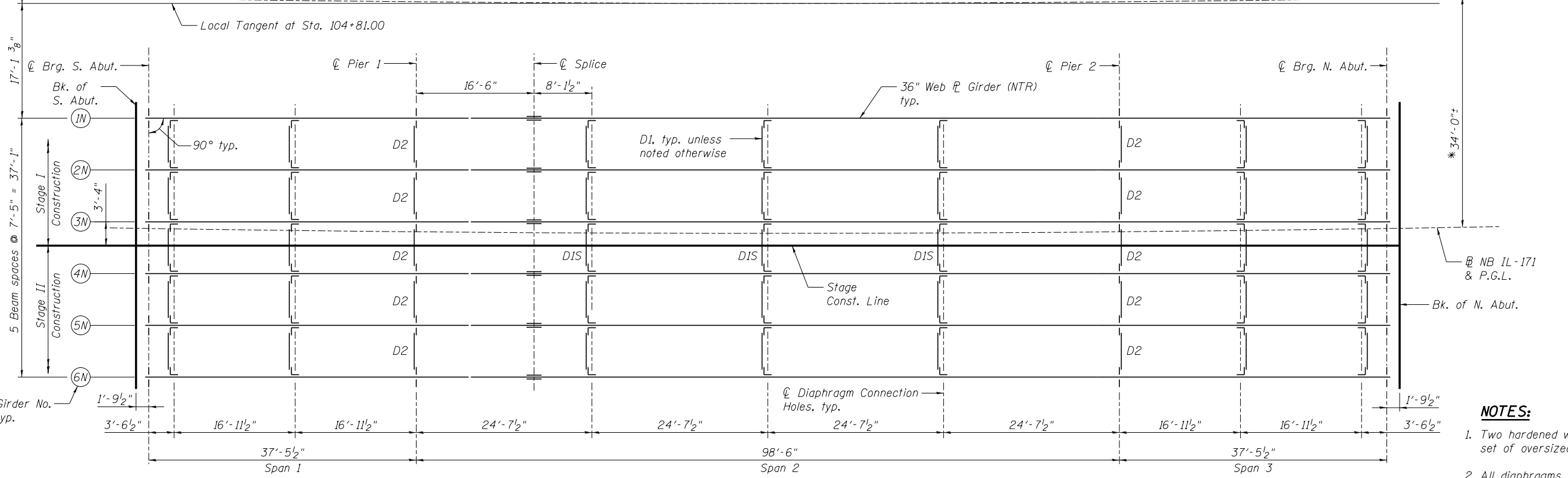
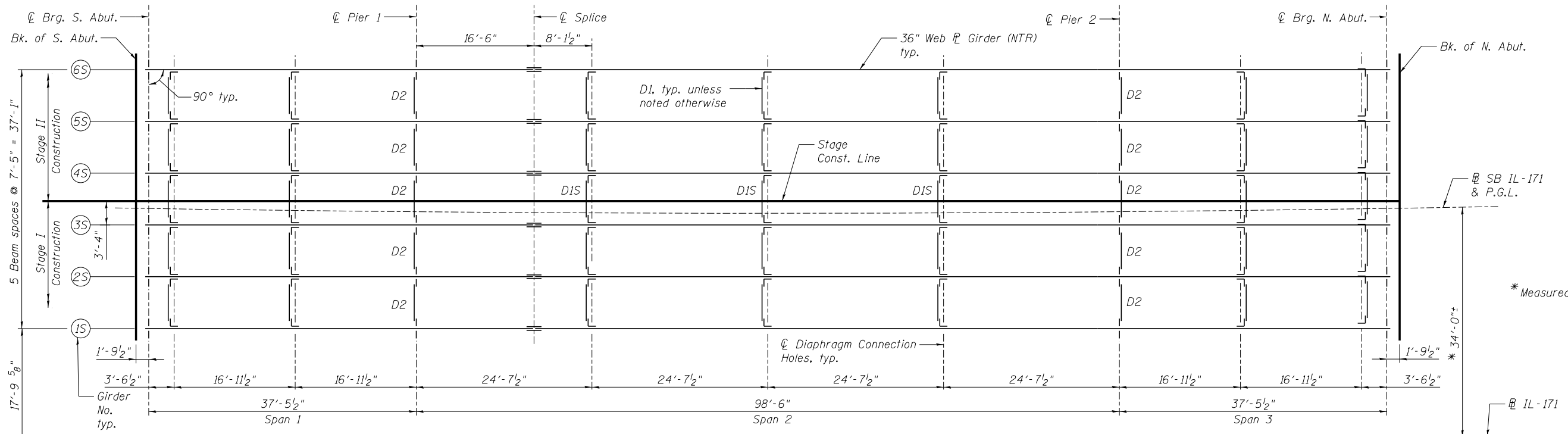

**FRAMING PLAN**

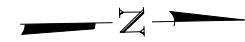

- NOTES:**
- Two hardened washers required for each set of oversized holes.
  - All diaphragms shall be installed as steel is erected and secured with erection pins and bolts except as otherwise noted. Individual diaphragms at supports may be temporarily disconnected to install bearing anchor rods.
  - Load carrying components designated "NTR" shall conform to the Impact Testing Requirements, Zone 2.

**benesch**  
engineers · scientists · planners

Alfred Benesch & Company  
205 North Michigan Avenue, Suite 2400  
Chicago, Illinois 60601  
312-565-0450 Job No. 10093

FILE NAME = 0161000\_60J16\_025.Framingplan.dgn

USER NAME = jsurber  
DESIGNED - JDM  
CHECKED - RMM  
DRAWN - MAK  
PLOT DATE = 12/20/2012

REVISIED -  
REVISIED -  
REVISIED -  
REVISIED -

**STATE OF ILLINOIS  
DEPARTMENT OF TRANSPORTATION**

**FRAMING PLAN  
STRUCTURE NO. 016-1000/1001**

SHEET NO. SA25 OF SA40 SHEETS

| F.A.P. RTE.               | SECTION     | COUNTY | TOTAL SHEETS | SHEET NO. |
|---------------------------|-------------|--------|--------------|-----------|
| 372                       | 2013-038B-R | COOK   | 821          | 273       |
| CONTRACT NO. 60J16        |             |        |              |           |
| ILLINOIS FED. AID PROJECT |             |        |              |           |

X:\100005\10093\Eng\_Docs\_Phase\_1\1001\_1st\_Ave\_over\_47th\_St\Final\0161000\_60J16\_025.Framingplan.dgn 7/29/2014 2:00:30 PM

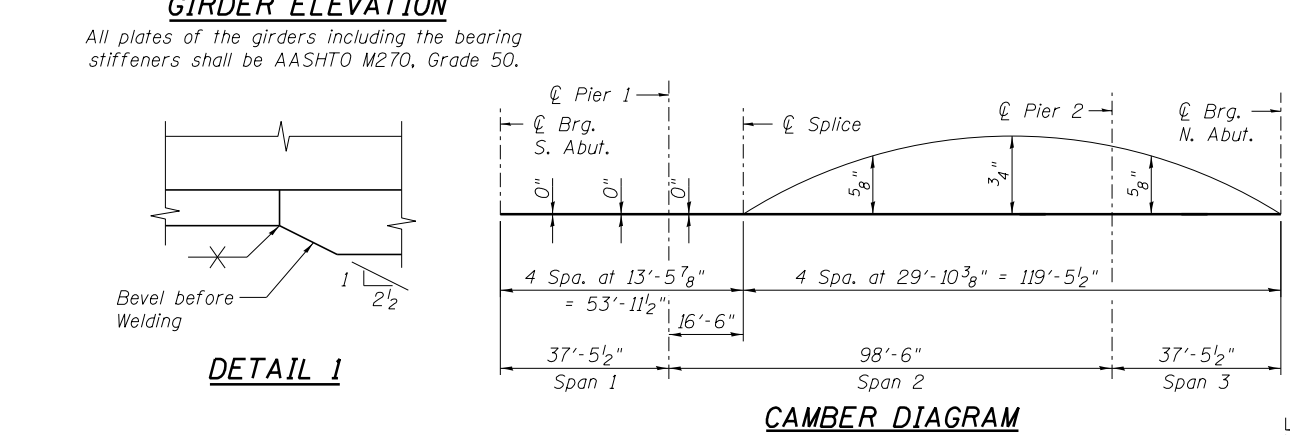
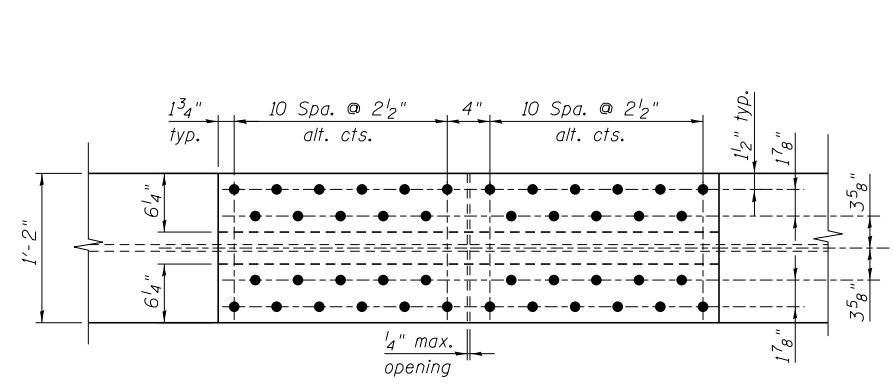
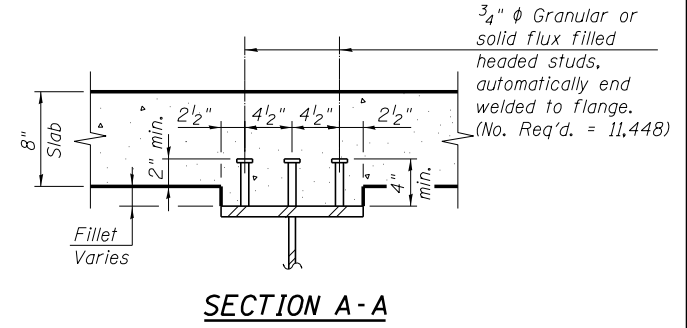
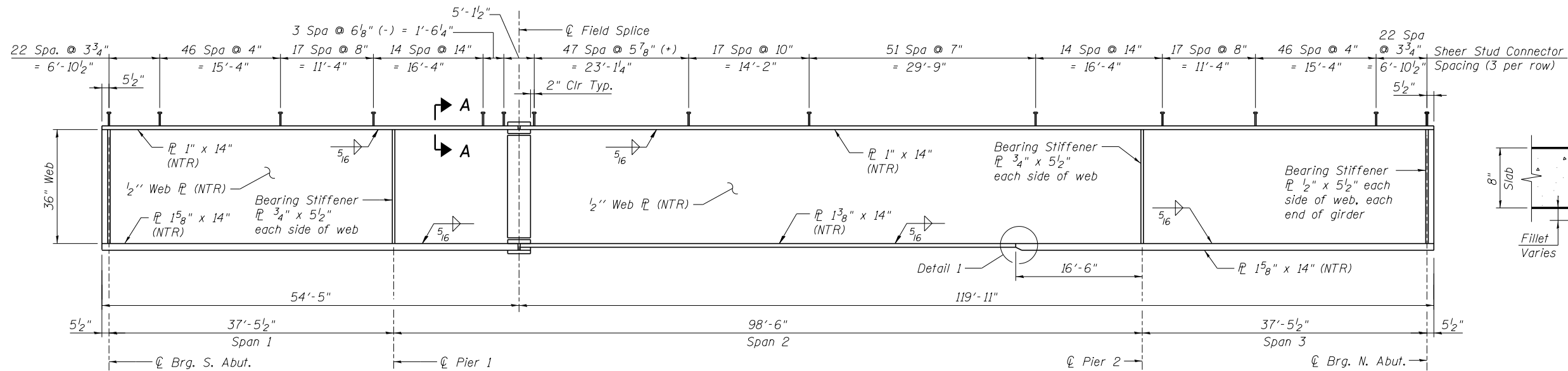

\*\*\* TOP OF WEB ELEVATIONS (SB)

| Location        | 1S     | 2S     | 3S     | 4S     | 5S     | 6S     |
|-----------------|--------|--------|--------|--------|--------|--------|
| ⊕ Brg. S. Abut. | 632.47 | 632.33 | 632.18 | 632.03 | 631.88 | 631.73 |
| ⊕ Brg. Pier 1   | 632.56 | 632.41 | 632.26 | 632.11 | 631.96 | 631.82 |
| ⊕ Splice        | 632.60 | 632.45 | 632.30 | 632.15 | 632.00 | 631.85 |
| ⊕ Brg. Pier 2   | 632.62 | 632.47 | 632.32 | 632.18 | 632.03 | 631.88 |
| ⊕ Brg. N. Abut. | 632.56 | 632.41 | 632.26 | 632.11 | 631.96 | 631.81 |

\*\*\* TOP OF WEB ELEVATIONS (NB)

| Location        | 1N     | 2N     | 3N     | 4N     | 5N     | 6N     |
|-----------------|--------|--------|--------|--------|--------|--------|
| ⊕ Brg. S. Abut. | 631.87 | 632.02 | 632.17 | 632.32 | 632.47 | 632.62 |
| ⊕ Brg. Pier 1   | 631.96 | 632.10 | 632.25 | 632.40 | 632.55 | 632.70 |
| ⊕ Splice        | 631.99 | 632.14 | 632.29 | 632.43 | 632.58 | 632.73 |
| ⊕ Brg. Pier 2   | 632.01 | 632.16 | 632.31 | 632.46 | 632.61 | 632.76 |
| ⊕ Brg. N. Abut. | 631.95 | 632.10 | 632.24 | 632.39 | 632.54 | 632.69 |

\*\*\*For Fabrication Only

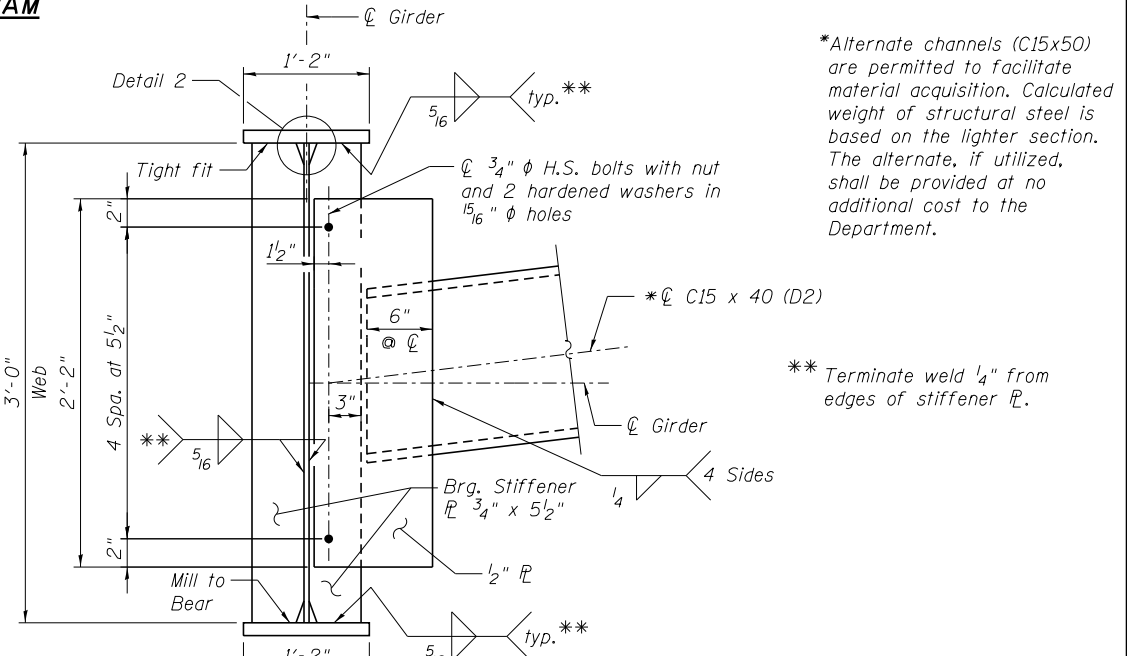
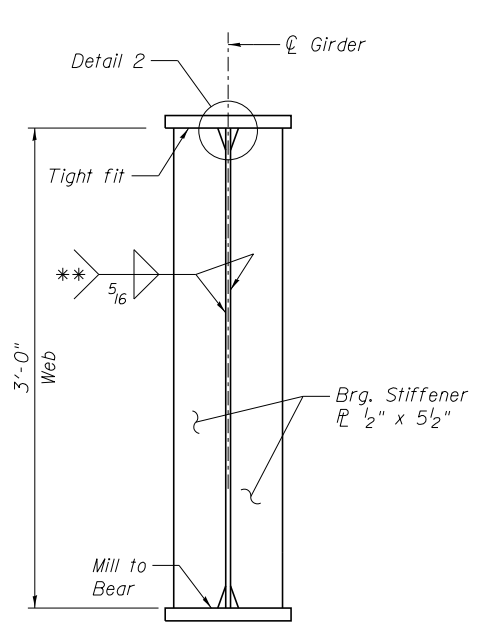
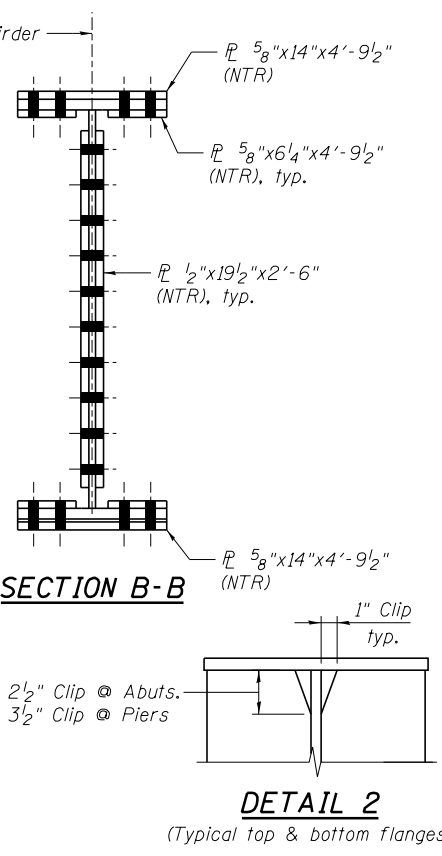
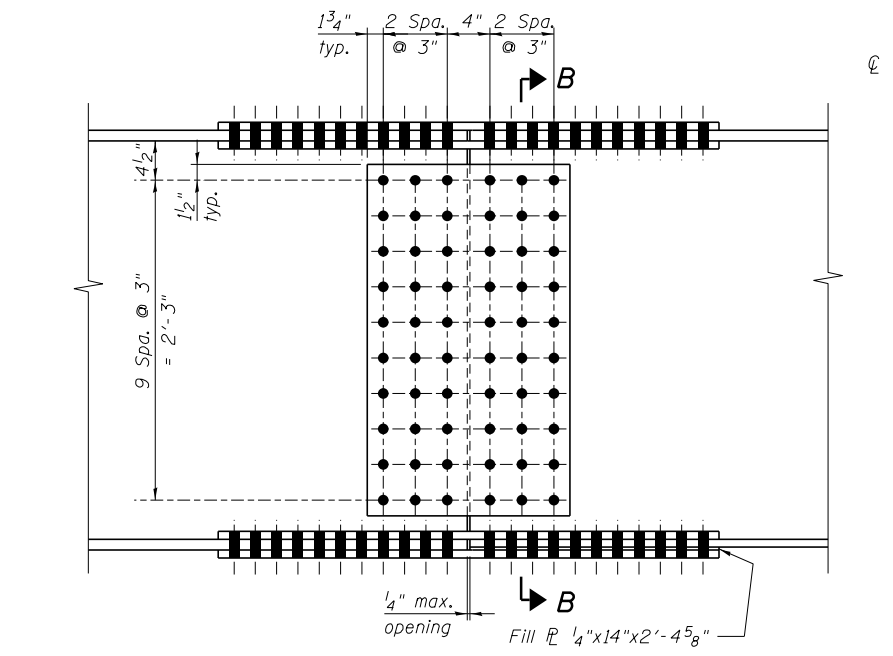

- NOTES:**
- Two hardened washers required for each set of oversized holes.
  - Load carrying components designated "NTR" shall conform to the Impact Testing Requirements, Zone 2.

**benesch**  
 engineers · scientists · planners

Alfred Benesch & Company  
 205 North Michigan Avenue, Suite 2400  
 Chicago, Illinois 60601  
 312-565-0450 Job No. 10093

| FILE NAME :                    | USER NAME : | DESIGNED : | REVISIONS : |
|--------------------------------|-------------|------------|-------------|
| 0161000_60J16_026.stldet.1.dgn | jsurber     | JDM        | -           |
|                                |             | RMM        | -           |
|                                |             | MAK        | -           |
|                                |             | RMM        | -           |

**STATE OF ILLINOIS**  
**DEPARTMENT OF TRANSPORTATION**

**STRUCTURAL STEEL DETAILS (1 OF 2)**  
**STRUCTURE NO. 016-1000/1001**  
 SHEET NO. SA26 OF SA40 SHEETS

| F.A.P. RTE. | SECTION     | COUNTY | TOTAL SHEETS | SHEET NO. |
|-------------|-------------|--------|--------------|-----------|
| 372         | 2013-038B-R | COOK   | 821          | 274       |

CONTRACT NO. 60J16  
 ILLINOIS FED. AID PROJECT

X:\100005\10093\Eng\_Docs\_Phase\_1\11\SN\_016\_1000\_1001\_1st\_Ave\_over\_47th\_St\_V.ina\0161000\_60J16\_026.stldet.1.dgn 9:40:56 AM 7/29/2014

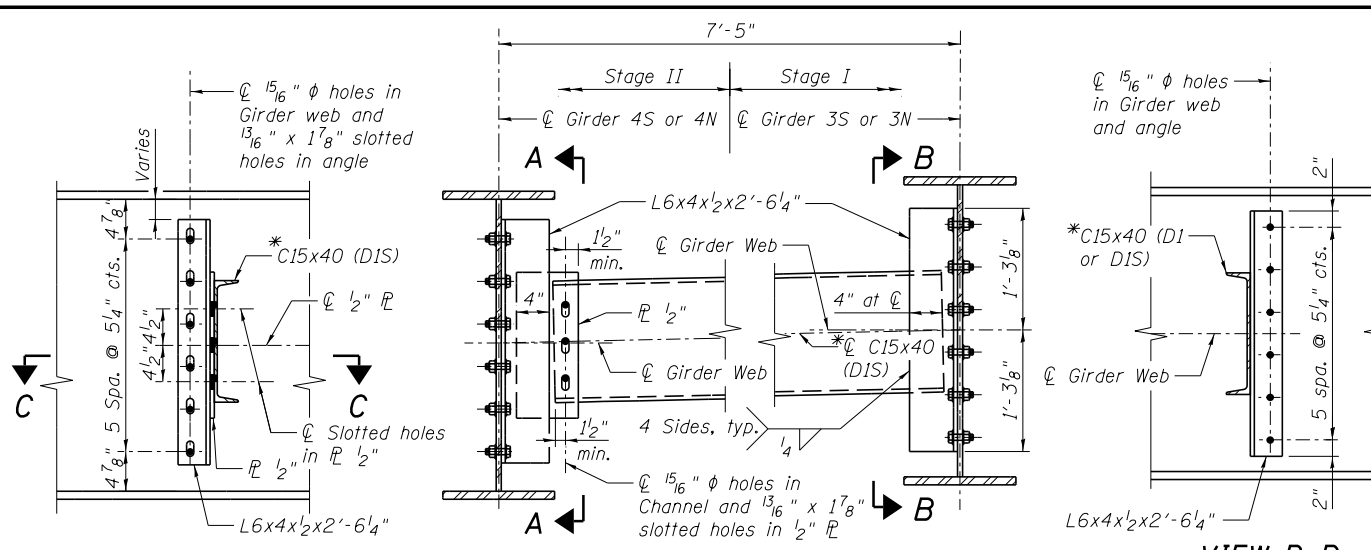

\*Alternate channels (C15x50) are permitted to facilitate material acquisition. Calculated weight of structural steel is based on the lighter section. The alternate, if utilized, shall be provided at no additional cost to the Department.

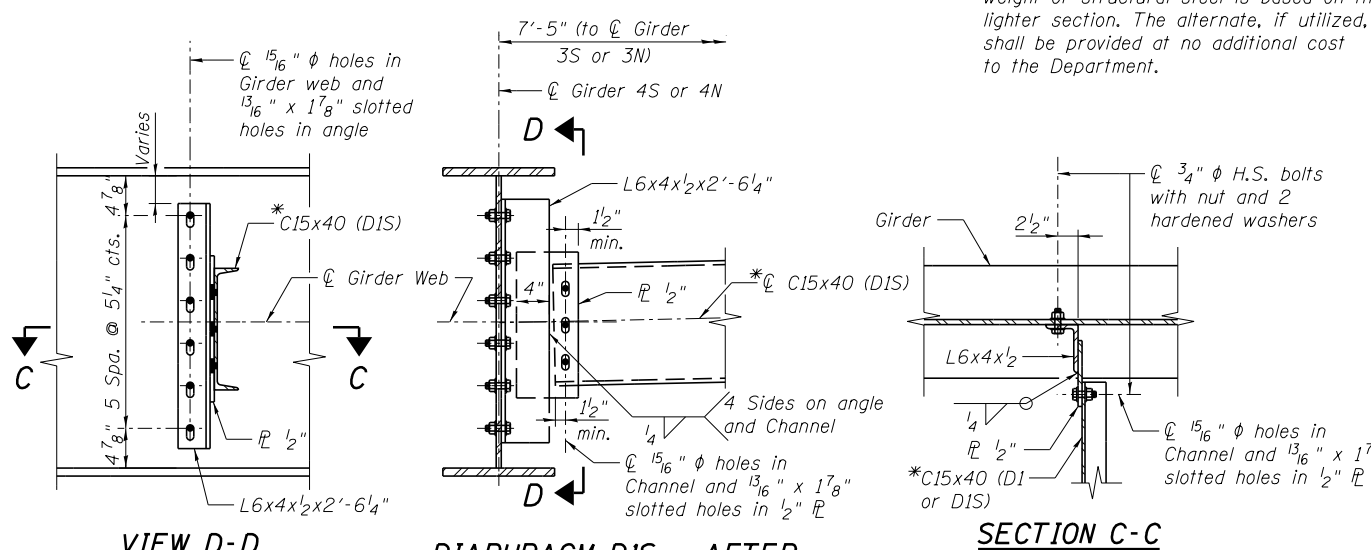

**SECTION C-C**  
(Section shown taken at Views A-A & D-D. Section shown is similar and opposite hand for View B-B.)

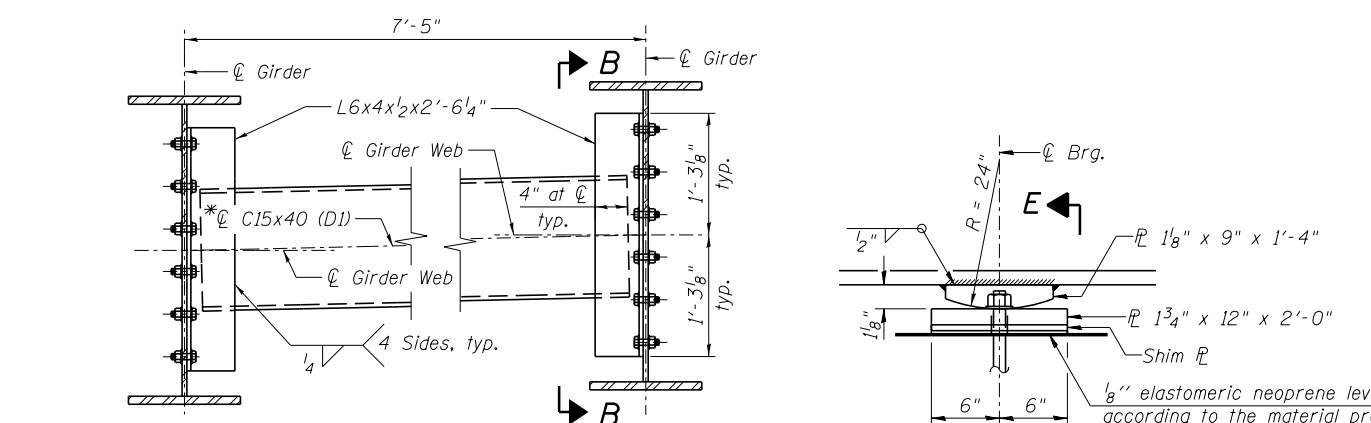

| EXTERIOR GIRDER MOMENT TABLE       |                          |             |            |
|------------------------------------|--------------------------|-------------|------------|
|                                    | 0.4 Sp. 1<br>0.6 Sp. 3   | Pier 1 or 2 | 0.5 Span 2 |
| $I_s$                              | (in <sup>4</sup> ) 14272 | 14272       | 13264      |
| $I_c(n)$                           | (in <sup>4</sup> ) 36333 | 36333       | 32748      |
| $I_c(3n)$                          | (in <sup>4</sup> ) 26193 | 26193       | 23966      |
| $I_c(cr)$                          | (in <sup>4</sup> ) 18687 | 18687       | -----      |
| $S_s$                              | (in <sup>3</sup> ) 646   | 646         | 762        |
| $S_c(n)$                           | (in <sup>3</sup> ) 1146  | 1146        | 1013       |
| $S_c(3n)$                          | (in <sup>3</sup> ) 1056  | 1056        | 934        |
| $S_c(cr)$                          | (in <sup>3</sup> ) 984   | 984         | -----      |
| DC1                                | (k/')                    | 1.008       | 1.008      |
| M <sub>DC1</sub>                   | (k)                      | -105        | -686       |
| DC2                                | (k/')                    | 0.150       | 0.150      |
| M <sub>DC2</sub>                   | (k)                      | -17         | -105       |
| DW                                 | (k/')                    | 0.340       | 0.340      |
| M <sub>DW</sub>                    | (k)                      | -38         | -237       |
| M <sub>Δ + IM</sub>                | (k)                      | -369        | -943       |
| M <sub>u</sub> (Strength I)        | (k)                      | -855        | -2995      |
| φ <sub>r</sub> M <sub>n</sub>      | (k)                      | 5403        | 3244       |
| $f_s$ DC1                          | (ksi)                    | -1.9        | -12.7      |
| $f_s$ DC2                          | (ksi)                    | -0.2        | -1.3       |
| $f_s$ DW                           | (ksi)                    | -0.5        | -2.9       |
| $f_s$ (Δ + IM)                     | (ksi)                    | -4.5        | -11.5      |
| $f_s$ (Service II)                 | (ksi)                    | -8.5        | -31.9      |
| 0.95R <sub>n</sub> F <sub>yr</sub> | (ksi)                    | 47.5        | 47.5       |
| $f_s$ (Total)(Strength I)          | (ksi)                    |             |            |
| φ <sub>r</sub> F <sub>n</sub>      | (ksi)                    |             |            |
| V <sub>r</sub>                     | (k)                      | 51.7        | 45.6       |

| EXTERIOR GIRDER REACTION TABLE |          |       |
|--------------------------------|----------|-------|
|                                | Abut.    | Pier  |
| *R <sub>DC1</sub>              | (k) 33.8 | 86.4  |
| R <sub>DC2</sub>               | (k) 0.02 | 12.99 |
| R <sub>DW</sub>                | (k) 0.04 | 29.44 |
| R <sub>Δ + IM</sub>            | (k) 62.4 | 122.7 |
| R <sub>Total</sub>             | (k) 96.2 | 251.5 |

\*Reaction also includes approach slab and concrete diaphragm.

**NOTES FOR FIXED BEARINGS:**

- Anchor bolts shall be ASTM F1554 all-thread (or an Engineer-approved alternate material) of the grade(s) and diameter(s) specified. The corresponding specified grade of AASHTO M314 anchor bolts may be used in lieu of ASTM F1554.
- Anchor bolts at fixed bearings may be either cast in place or installed in holes drilled after the supported member is in place.
- Drilled and set anchor bolts shall be installed according to Article 521.06 of the Standard Specifications.
- Two 1/8 in. adjusting shims shall be provided for each bearing in addition to all other plates and placed as shown on bearing details.
- The structural steel plates and pintles of the fixed bearings shall conform to requirements of AASHTO M270 Grade 50.

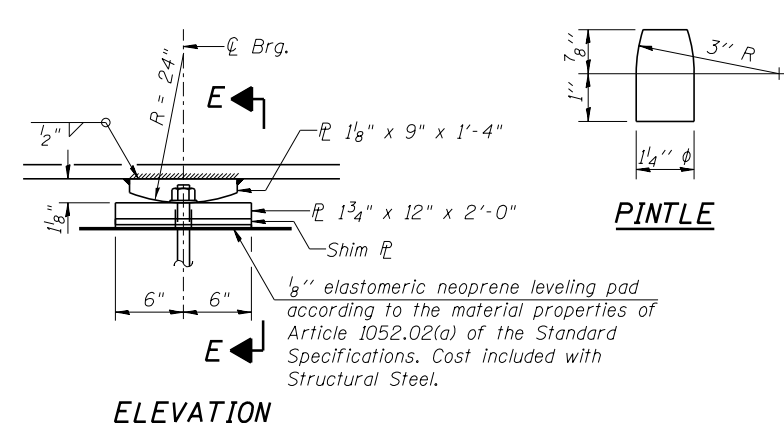

**FIXED BEARING AT PIER 2**

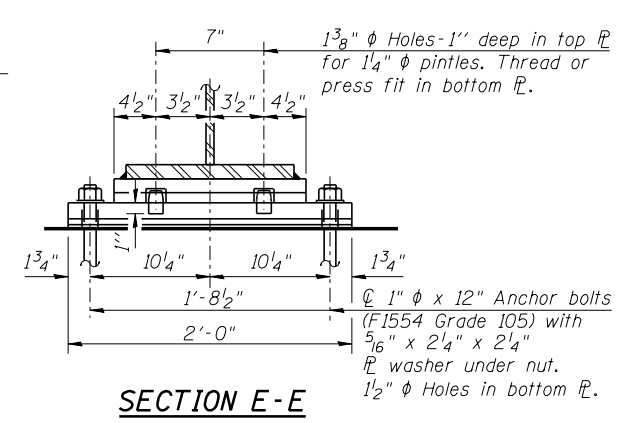

$I_s, S_s$ : Non-composite moment of inertia and section modulus of the steel section used for computing  $f_s$  (Total-Strength I, and Service II) due to non-composite dead loads (in<sup>4</sup> and in<sup>3</sup>).

$I_c(n), S_c(n)$ : Composite moment of inertia and section modulus of the steel and deck based upon the modular ratio, "n", used for computing  $f_s$  (Total-Strength I, and Service II) in uncracked sections, due to short-term composite live loads (in<sup>4</sup> and in<sup>3</sup>).

$I_c(3n), S_c(3n)$ : Composite moment of inertia and section modulus of the steel and deck based upon 3 times the modular ratio, "3n", used for computing  $f_s$  (Total-Strength I, and Service II) in uncracked sections, due to long-term composite (superimposed) dead loads (in<sup>4</sup> and in<sup>3</sup>).

$I_c(cr), S_c(cr)$ : Composite moment of inertia and section modulus of the steel and longitudinal deck reinforcement, used for computing  $f_s$  (Total-Strength I and Service II) in cracked sections, due to both short-term composite live loads and long-term composite (superimposed) dead loads (in<sup>4</sup> and in<sup>3</sup>).

DC1: Un-factored non-composite dead load (kips/ft.).

M<sub>DC1</sub>: Un-factored moment due to non-composite dead load (kip-ft.).

DC2: Un-factored long-term composite (superimposed excluding future wearing surface) dead load (kips/ft.).

M<sub>DC2</sub>: Un-factored moment due to long-term composite (superimposed excluding future wearing surface) dead load (kip-ft.).

DW: Un-factored long-term composite (superimposed future wearing surface only) dead load (kips/ft.).

M<sub>DW</sub>: Un-factored moment due to long-term composite (superimposed future wearing surface only) dead load (kip-ft.).

M<sub>Δ + IM</sub>: Un-factored live load moment plus dynamic load allowance (impact) (kip-ft.).

M<sub>u</sub> (Strength I): Factored design moment (kip-ft.).

1.25 (M<sub>DC1</sub> + M<sub>DC2</sub>) + 1.5 M<sub>DW</sub> + 1.75 M<sub>Δ + IM</sub>

φ<sub>r</sub>M<sub>n</sub>: Compact composite positive moment capacity computed according to Article 6.10.7.1 (kip-ft.) or Non-Slender negative moment capacity according to Article A6.1.1 or A6.1.2 (kip-ft.).

$f_s$  DC1: Un-factored stress at edge of flange for controlling steel flange due to vertical non-composite dead loads as calculated below (ksi).

M<sub>DC1</sub> / S<sub>nc</sub>

$f_s$  DC2: Un-factored stress at edge of flange for controlling steel flange due to vertical composite dead loads as calculated below (ksi).

M<sub>DC2</sub> / S<sub>c(3n)</sub> or M<sub>DC2</sub> / S<sub>c(cr)</sub> as applicable.

$f_s$  DW: Un-factored stress at edge of flange for controlling steel flange due to vertical composite future wearing surface loads as calculated below (ksi).

M<sub>DW</sub> / S<sub>c(3n)</sub> or M<sub>DW</sub> / S<sub>c(cr)</sub> as applicable.

$f_s$  (Δ + IM): Un-factored stress at edge of flange for controlling steel flange due to vertical composite live plus impact loads as calculated below (ksi).

M<sub>Δ + IM</sub> / S<sub>c(n)</sub> or M<sub>DW</sub> / S<sub>c(cr)</sub> as applicable.

$f_s$  (Service II): Sum of stresses as computed below (ksi).

f<sub>SDC1</sub> + f<sub>SDC2</sub> + f<sub>SDW</sub> + 1.3 f<sub>s</sub> (Δ + IM)

0.95R<sub>n</sub>F<sub>yr</sub>: Composite stress capacity for Service II loading according to Article 6.10.4.2 (ksi).

f (Total)(Strength I): Sum of stresses as computed below on non-compact section (ksi).

1.25 (f<sub>SDC1</sub> + f<sub>SDC2</sub>) + 1.5 f<sub>SDW</sub> + 1.75 f<sub>s</sub> (Δ + IM)

φ<sub>r</sub>F<sub>n</sub>: Non-Compact composite positive or negative stress capacity for Strength I loading according to Article 6.10.7 or 6.10.8 (ksi).

V<sub>r</sub>: Maximum factored shear range in span computed according to Article 6.10.10.

**NOTES:**

- M<sub>Δ</sub> and R<sub>Δ</sub> include the effects of centrifugal force and superelevation.
- Exterior girder controls the design.
- Erect all Diaphragms DIS before the Stage II deck pour, finger-tightening bolts in slotted holes at the stage construction line. Bolts shall be fully tightened after Stage II deck pour.

**BILL OF MATERIAL**

| ITEM             | UNIT | TOTAL |
|------------------|------|-------|
| Anchor Bolts, 1" | Each | 24    |

**benesch**  
engineers · scientists · planners

Alfred Benesch & Company  
205 North Michigan Avenue, Suite 2400  
Chicago, Illinois 60601  
312-565-0450 Job No. 10093

|                                |                        |                |           |
|--------------------------------|------------------------|----------------|-----------|
| FILE NAME =                    | USER NAME = akeshchall | DESIGNED - JDM | REVISED - |
| 0161000.60J16.027.stldet.2.dgn |                        | CHECKED - RMM  | REVISED - |
|                                | PLOT SCALE =           | DRAWN - MAK    | REVISED - |
|                                | PLOT DATE = 12/20/2012 | CHECKED - RMM  | REVISED - |

STATE OF ILLINOIS  
DEPARTMENT OF TRANSPORTATION

STRUCTURAL STEEL DETAILS (2 OF 2)  
STRUCTURE NO. 016-1000/1001

SHEET NO. SA27 OF SA40 SHEETS

|                           |             |        |                    |           |
|---------------------------|-------------|--------|--------------------|-----------|
| F.A.P. RTE.               | SECTION     | COUNTY | TOTAL SHEETS       | SHEET NO. |
| 372                       | 2013-038B-R | COOK   | 821                | 275       |
| ILLINOIS FED. AID PROJECT |             |        | CONTRACT NO. 60J16 |           |

X:\100005\10093\Eng-Docs\_Phase\_1\1\SN\_016\_1000\_1001\_1st-Ave-over\_47th-St\Final\0161000.60J16.027.stldet.2.dgn 10:41:11 AM 8/1/2014

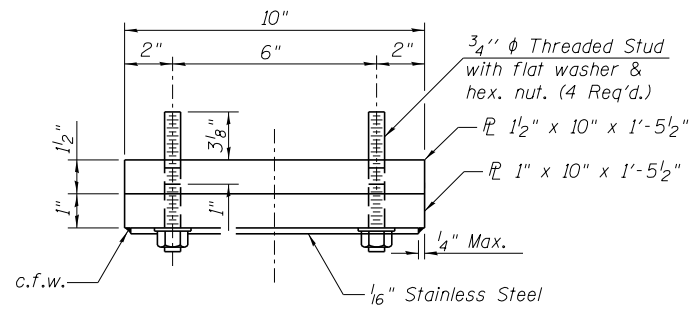

**TYPE II TOP BEARING ASSEMBLY**

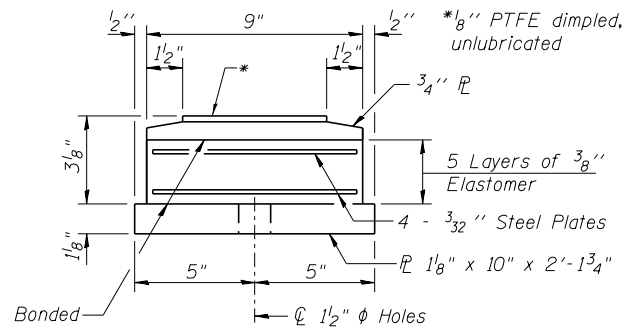

**TYPE II BOTTOM BEARING ASSEMBLY**

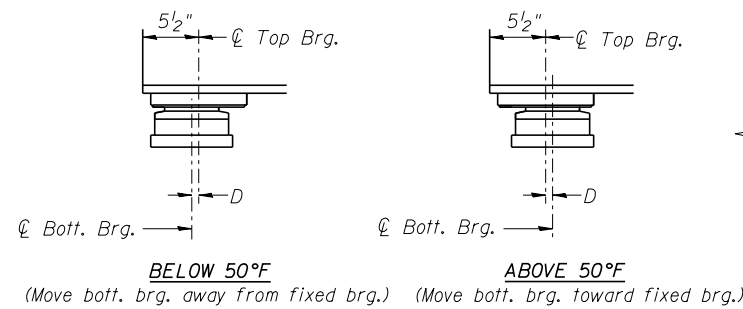

**SETTING ANCHOR BOLTS AT EXP. BRG.**

D = 1/8" per each 100' of expansion for every 15° temp. change from the normal temp. of 50°F.

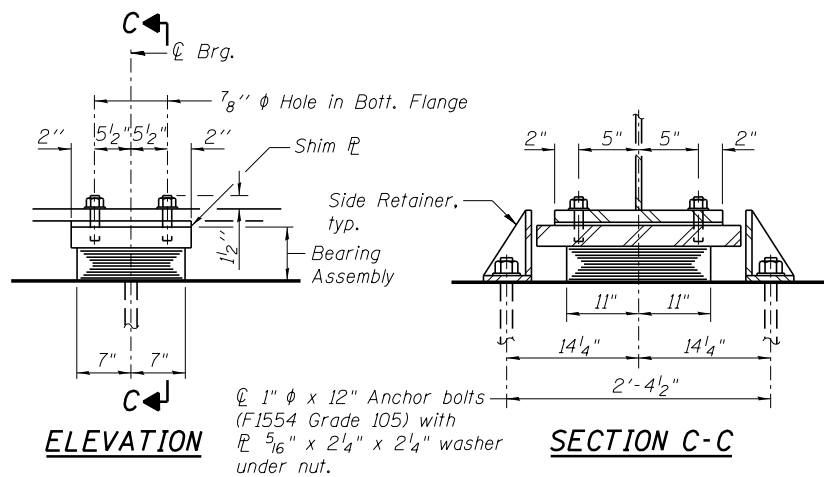

**TYPE I ELASTOMERIC EXP. BRG. AT PIER 1**

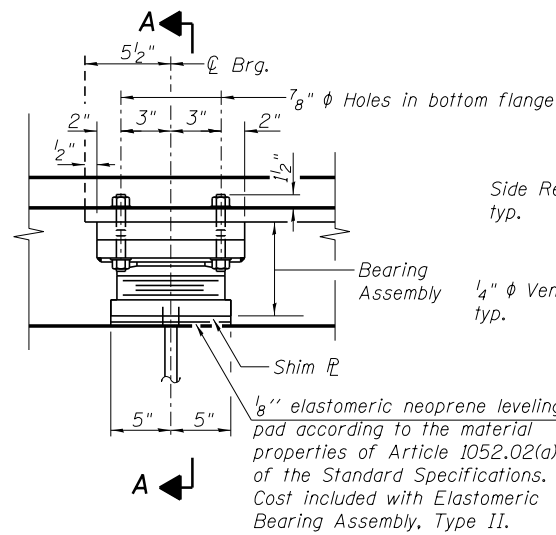

**TYPE II ELASTOMERIC EXP. BRG. AT S. ABUT.**

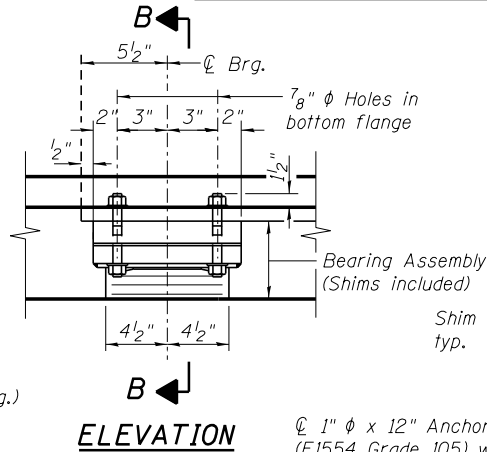

**TYPE I ELASTOMERIC EXP. BRG. AT N. ABUT.**

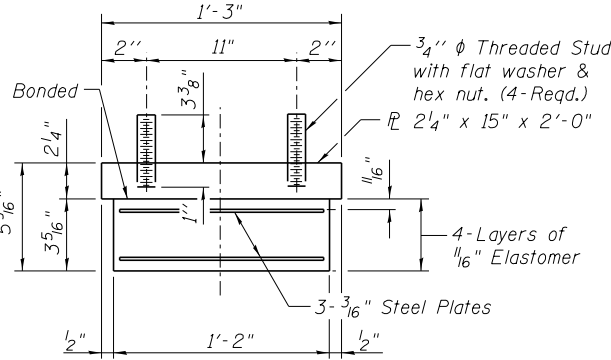

**TYPE I BEARING ASSEMBLY AT PIER 1**

Note: Shim plates shall not be placed under Type I Bearing Assembly.

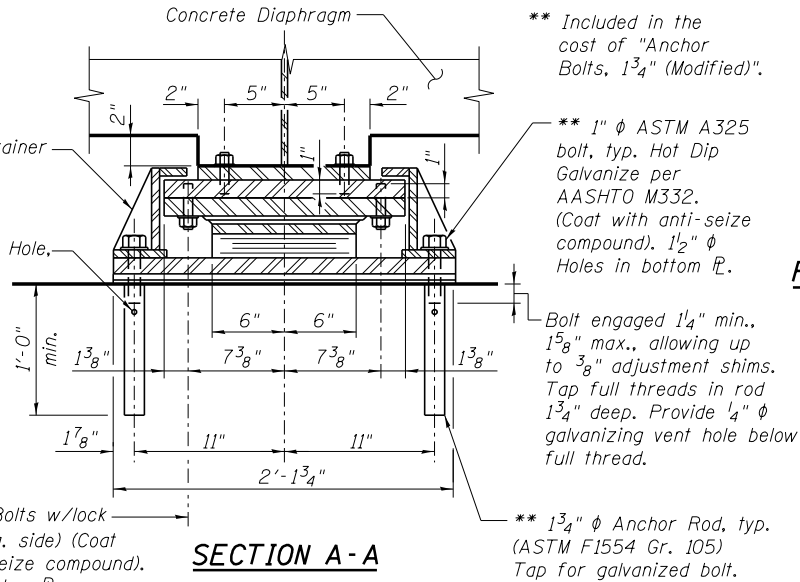

**TYPE I BEARING ASSEMBLY AT N. ABUT.**

Note: Shim plates shall not be placed under Type I Bearing Assembly.

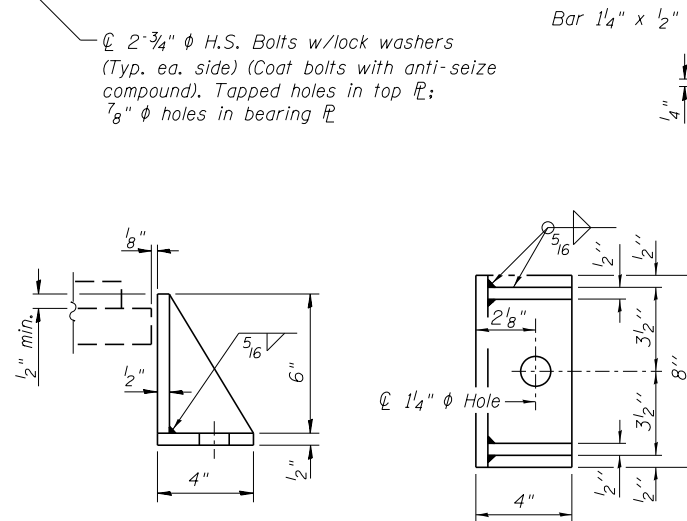

**SIDE RETAINER AT PIER 1**

Equivalent rolled angle with stiffeners will be allowed in lieu of welded plates.

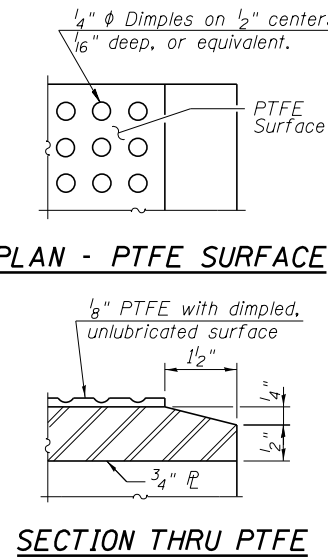

**PLAN - PTFE SURFACE**

**SECTION THRU PTFE**

**NOTES:**

- Anchor bolts shall be ASTM F1554 all-thread (or an Engineer-approved alternate material) of the grade(s) and diameter(s) specified. The corresponding specified grade of AASHTO M314 anchor bolts may be used in lieu of ASTM F1554.
- Anchor bolts for Type I bearing side retainers shall be installed in holes drilled before or after members are in place. Anchor rods for Type II bearings shall be installed in holes drilled before members are in place.
- Drilled and set anchor bolts and rods shall be installed according to Article 521.06 of the Standard Specifications, with a minimum allowable tension capacity of 18 kips.
- Side retainers and other steel members required for the elastomeric bearing assembly shall be included in the cost of Elastomeric Bearing Assembly, Type I or Type II.
- Two 1/8 in. adjusting shims shall be provided for each bearing in addition to all other plates and placed as shown on bearing details. Two 1/8 in. adjusting shims shall be provided for each side retainer at N. Abut. in addition to all other plates and placed as shown on bearing details.
- The structural steel plates of the bearing assembly shall conform to requirements of AASHTO M270 Grade 50.
- The 1/8" PTFE sheet shall be bonded directly to the top steel plate with a two-component, medium viscosity epoxy resin, conforming to the requirements of the Federal Specification MMM-A-134, Type I. The bond agent shall be applied on the full area of the contact surfaces.
- Bonding of 1/8" PTFE sheet during vulcanizing process will be permitted provided the process and method of adjusting assembly height is approved by the Engineer.

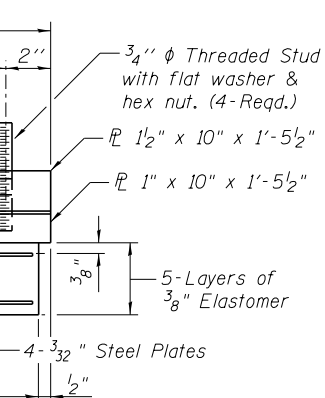

**TYPE I BEARING ASSEMBLY AT N. ABUT.**

Note: Shim plates shall not be placed under Type I Bearing Assembly.

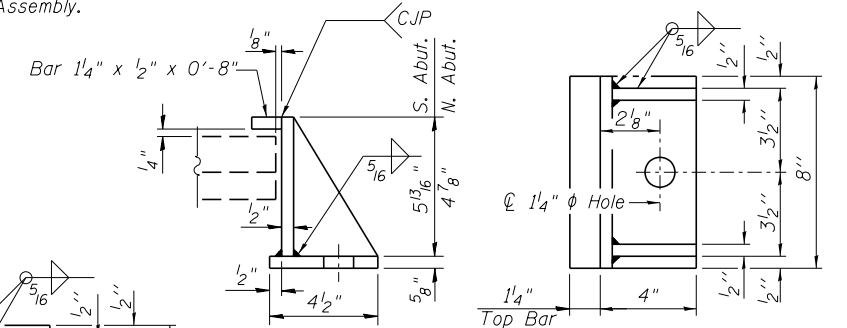

**SIDE RETAINER AT ABUTMENTS**

Equivalent rolled angle with stiffeners will be allowed in lieu of welded plates.

**BILL OF MATERIAL**

| ITEM                                  | UNIT | TOTAL |
|---------------------------------------|------|-------|
| Elastomeric Bearing Assembly, Type I  | Each | 24    |
| Elastomeric Bearing Assembly, Type II | Each | 12    |
| Anchor Bolts, 1"                      | Each | 48    |
| Anchor Bolts, 1 3/4" (Modified)       | Each | 24    |

| FILE NAME :                       | USER NAME : | DESIGNED : | REVISIONS : |
|-----------------------------------|-------------|------------|-------------|
| 0161000.60J16.028.elastbrgdet.dgn | jsurber     | RMM        |             |
|                                   |             | CHECKED :  | REVISIONS : |
|                                   |             | MAK        |             |
|                                   |             | DRAWN :    | REVISIONS : |
|                                   |             | RMM        |             |
|                                   |             | CHECKED :  | REVISIONS : |
|                                   |             | RMM        |             |

| F.A.P. R.E.               | SECTION     | COUNTY | TOTAL SHEETS | SHEET NO.          |
|---------------------------|-------------|--------|--------------|--------------------|
| 372                       | 2013-038B-R | COOK   | 821          | 276                |
|                           |             |        |              | CONTRACT NO. 60J16 |
| ILLINOIS FED. AID PROJECT |             |        |              |                    |



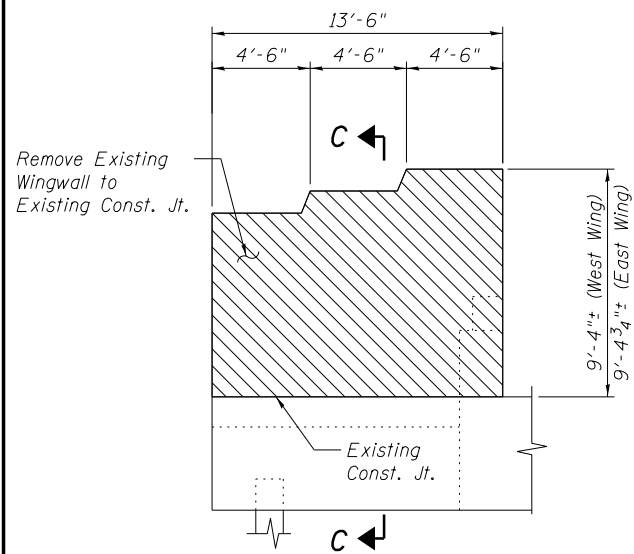

TYPICAL WINGWALL ELEVATION

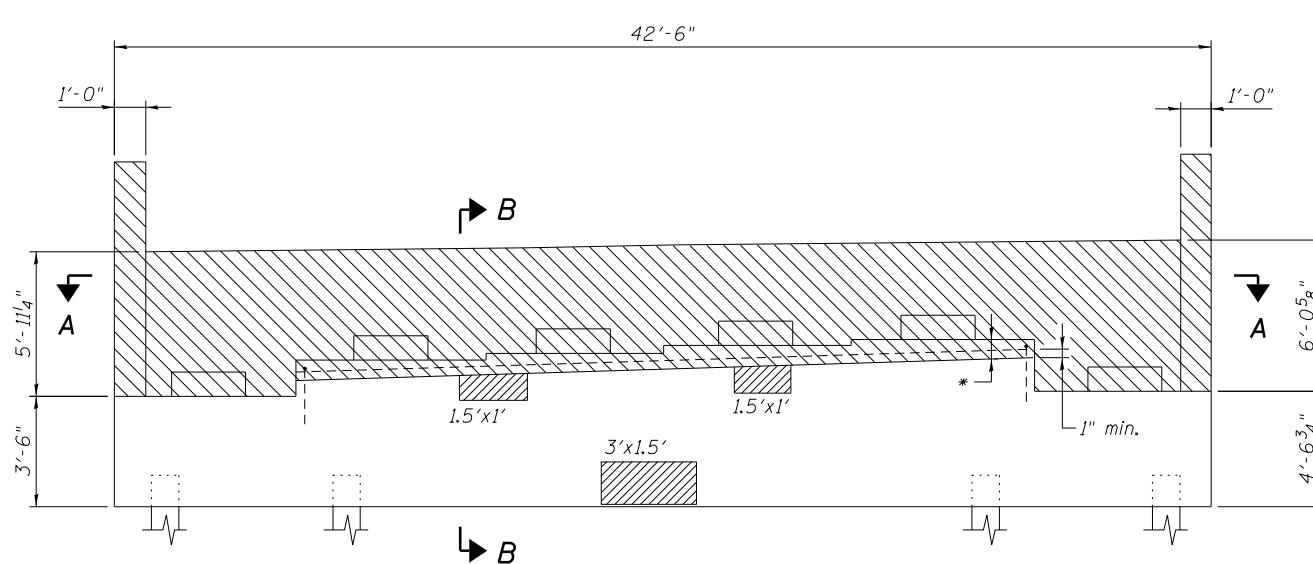

ELEVATION - SN 016-1000  
(Looking North)

\* 3" below abutment seat or 1" min. below existing transverse reinforcement; whichever is greater. Existing exposed reinforcement shall be cleaned and incorporated into the new construction. Cost included with concrete removal.

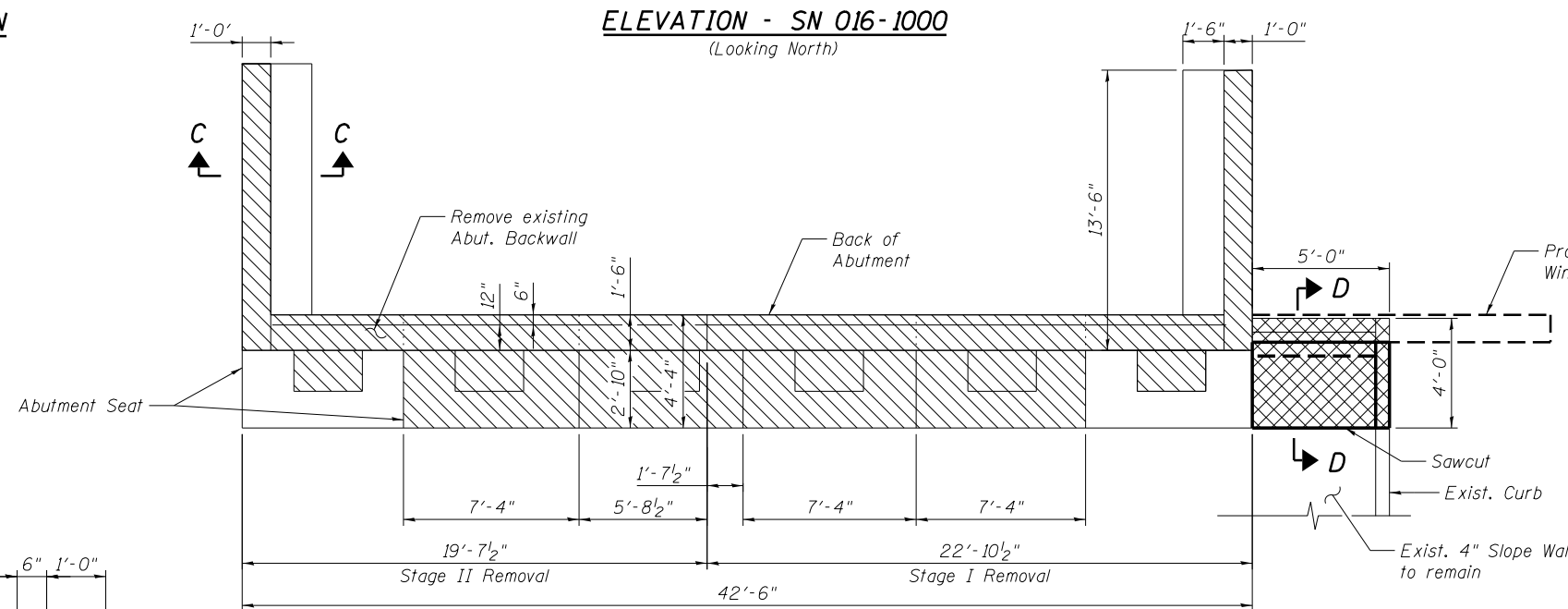

SECTION A-A

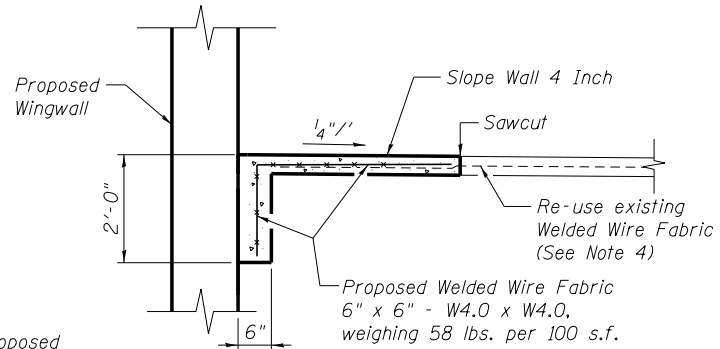

SECTION D-D

LEGEND

- Concrete Removal
- Structural Repair of Concrete (Depth Equal to or Less Than 5 Inches)
- Slope Wall Removal (See Note 4)

NOTES:

1. Actual quantities of repairs shall be approved by the Engineer.
2. Existing vertical reinforcement shall be cut flush with the the concrete removal surface, except as noted. Cost included with "Concrete Removal".
3. See Sheet SA2 for Pay Limits of "Structure Excavation".
4. Replace Slope Wall in-kind up to front face of Proposed Wingwall. Re-use existing Welded Wire Fabric. Cost to re-use fabric is included with "Slope Wall 4 inch".

BILL OF MATERIAL

| ITEM   | UNIT    | TOTAL |
|--|---------|-------|
| Structure Excavation   | Cu. Yd. | 98    |
| Granular Backfill for Structures                                     | Cu. Yd. | 96    |
| Concrete Removal   | Cu. Yd. | 27.3  |
| Structural Repair of Concrete (Depth Equal to or Less Than 5 Inches) | Sq. Ft. | 8     |
| Slope Wall Removal   | Sq. Yd. | 2     |
| Slope Wall 4 inch  | Sq. Yd. | 2     |

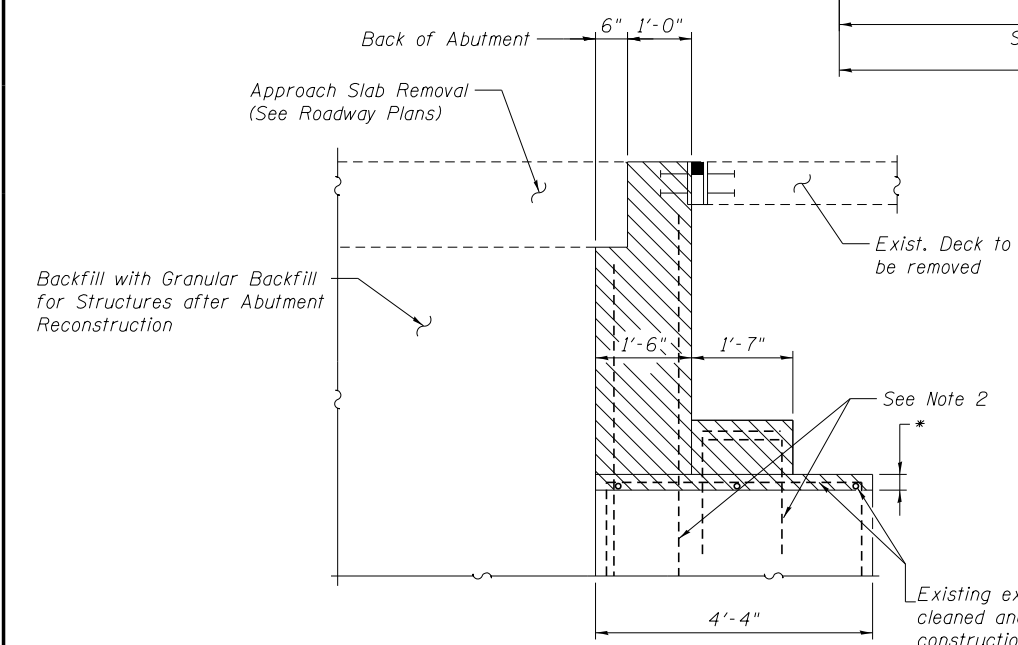

SECTION B-B

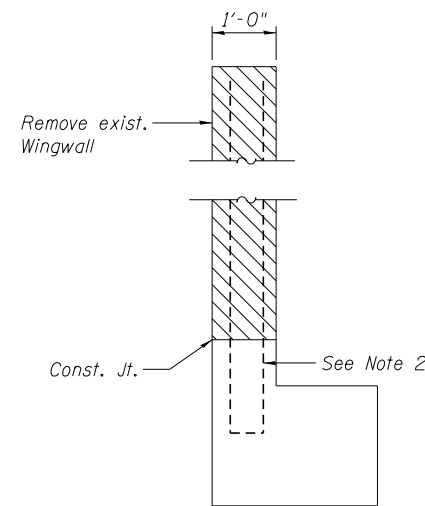

SECTION C-C

Existing exposed reinforcement shall be cleaned and incorporated into the new construction. Cost included with concrete removal.

**benesch**  
engineers · scientists · planners

Alfred Benesch & Company  
205 North Michigan Avenue, Suite 2400  
Chicago, Illinois 60601  
312-565-0450 Job No. 10093

|                                      |                        |                |           |
|--------------------------------------|------------------------|----------------|-----------|
| FILE NAME =                          | USER NAME = tjenicke   | DESIGNED - RMM | REVISED - |
| 0161000.60J16.029.NAbutRepair_SB.dgn | PLOT SCALE =           | CHECKED - DJM  | REVISED - |
|                                      | PLOT DATE = 12/20/2012 | DRAWN - MAK    | REVISED - |
|                                      |                        | CHECKED - RMM  | REVISED - |

STATE OF ILLINOIS  
DEPARTMENT OF TRANSPORTATION

NORTH ABUTMENT CONCRETE REMOVAL AND REPAIR DETAILS  
STRUCTURE NO. 016-1000/1001

| F.A.P. RTE.        | SECTION     | COUNTY | TOTAL SHEETS              | SHEET NO. |
|--------------------|-------------|--------|---------------------------|-----------|
| 372                | 2013-038B-R | COOK   | 821                       | 277       |
| CONTRACT NO. 60J16 |             |        | ILLINOIS FED. AID PROJECT |           |

SHEET NO. SA29 OF SA40 SHEETS

X:\1000005\100093\Eng\_Docs\_Phase\_1\11\SN\_016\_1000\_1001\_1st\_Ave\_over\_47th\_St\Final\01610000\_60J16\_029\_NAbutRepair\_SB.dgn 6/23/2014 2:28:17 PM

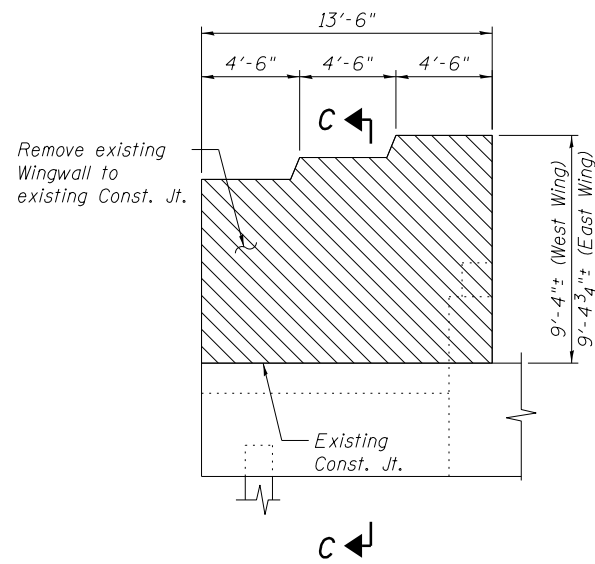

TYPICAL WINGWALL ELEVATION

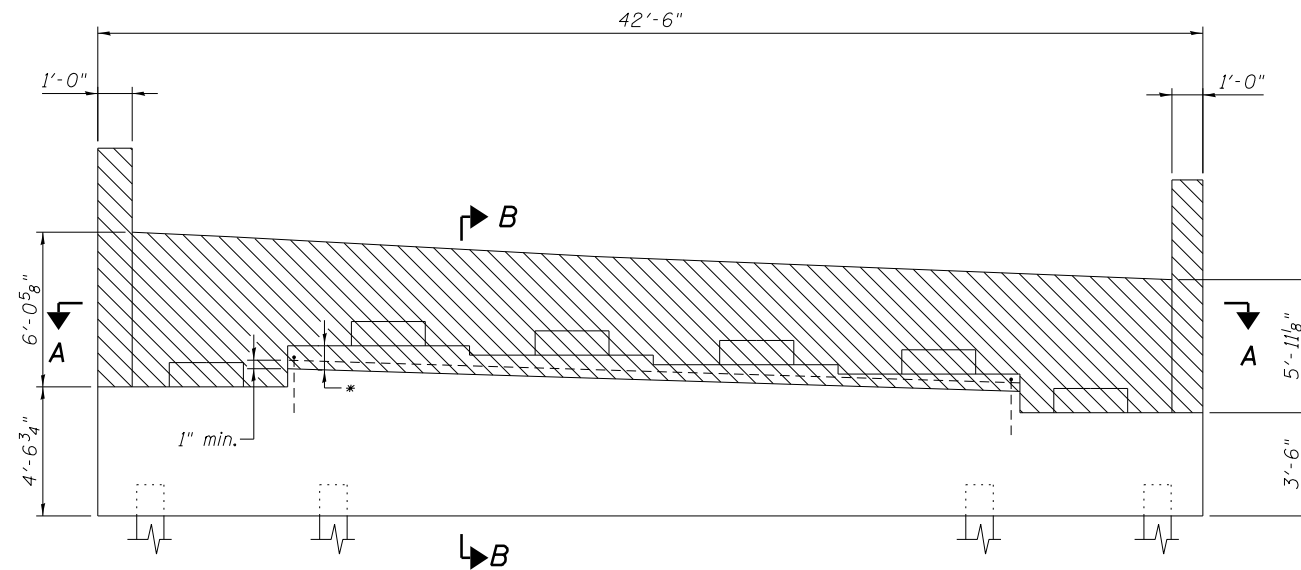

ELEVATION - SN 016-1000  
(Looking South)

\* 4" below abutment seat or 1" min. below existing transverse reinforcement; whichever is greater. Existing exposed reinforcement shall be cleaned and incorporated into the new construction. Cost included with concrete removal.

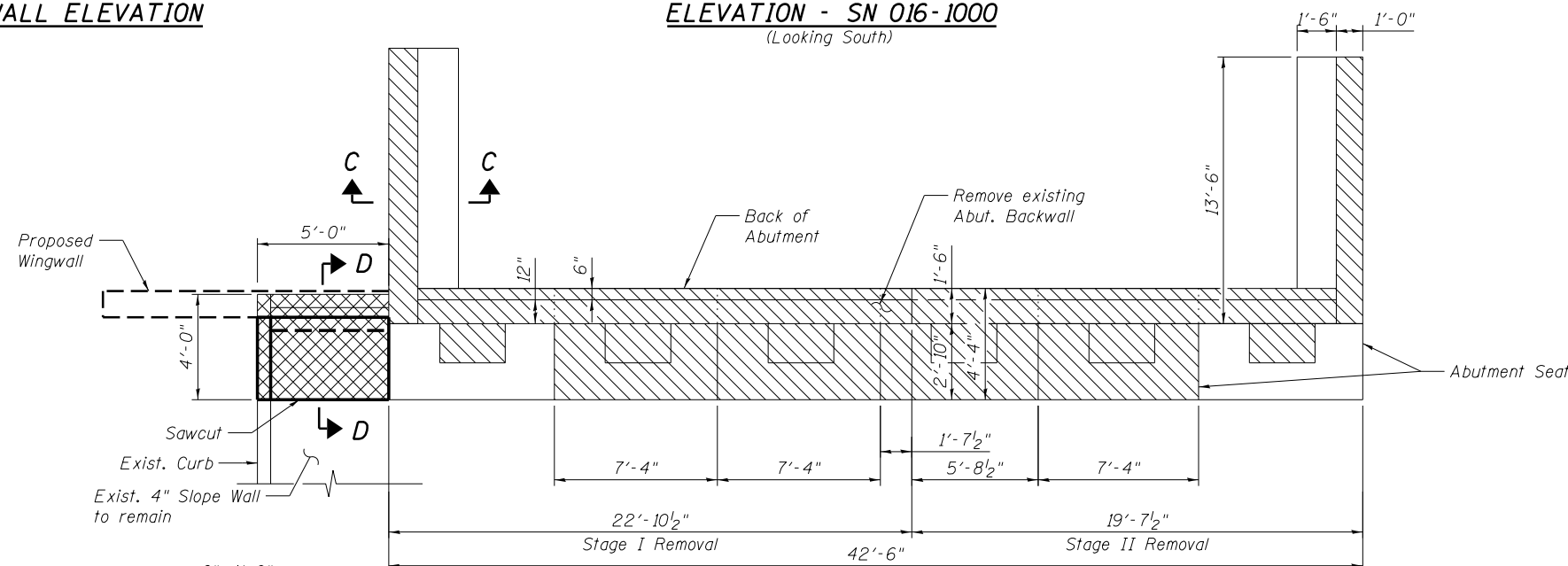

SECTION A-A

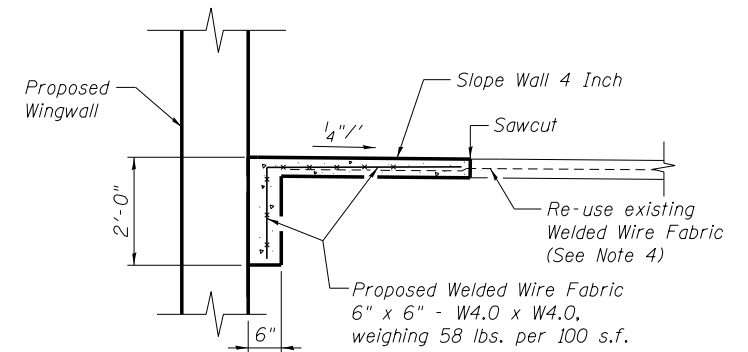

SECTION D-D

LEGEND

- Concrete Removal
- Slope Wall Removal (See Note 4)

NOTES:

1. Actual quantities of repairs shall be approved by the Engineer.
2. Existing vertical reinforcement shall be cut flush with the the concrete removal surface, except as noted. Cost included with "Concrete Removal".
3. See Sheet SA2 for Pay Limits of "Structure Excavation".
4. Replace Slope Wall in-kind up to front face of Proposed Wingwall. Re-use existing Welded Wire Fabric. Cost to re-use fabric is included with "Slope Wall 4 inch".

BILL OF MATERIAL

| ITEM                             | UNIT    | TOTAL |
|----------------------------------|---------|-------|
| Structure Excavation             | Cu. Yd. | 98    |
| Granular Backfill for Structures | Cu. Yd. | 96    |
| Concrete Removal                 | Cu. Yd. | 27.3  |
| Slope Wall Removal               | Sq. Yd. | 2     |
| Slope Wall 4 inch                | Sq. Yd. | 2     |

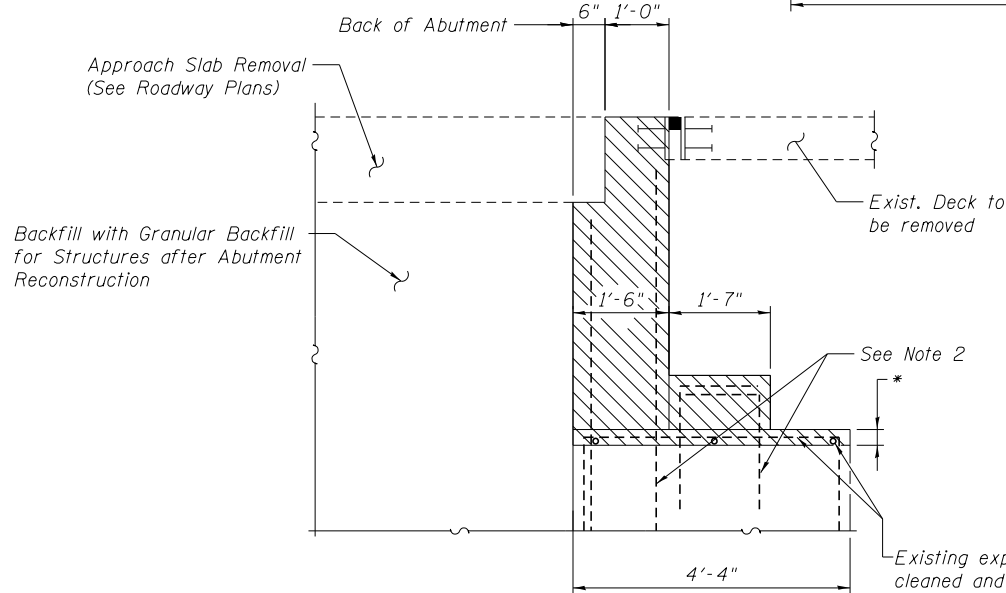

SECTION B-B

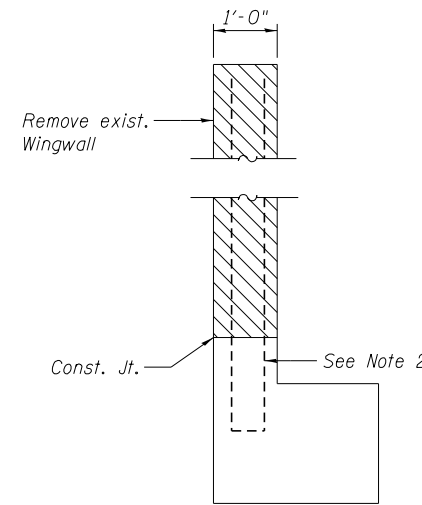

SECTION C-C

Existing exposed reinforcement shall be cleaned and incorporated into the new construction. Cost included with concrete removal.

**benesch**  
engineers · scientists · planners  
Alfred Benesch & Company  
205 North Michigan Avenue, Suite 2400  
Chicago, Illinois 60601  
312-565-0450 Job No. 10093

|                                      |                        |                |           |
|--------------------------------------|------------------------|----------------|-----------|
| FILE NAME =                          | USER NAME = tjenicke   | DESIGNED - RMM | REVISED - |
| 0161000_60J16_030_SAbutRepair_SB.dgn |                        | CHECKED - DJM  | REVISED - |
|                                      | PLOT SCALE =           | DRAWN - MAK    | REVISED - |
|                                      | PLOT DATE = 12/20/2012 | CHECKED - RMM  | REVISED - |

STATE OF ILLINOIS  
DEPARTMENT OF TRANSPORTATION

SOUTH ABUTMENT CONCRETE REMOVAL AND REPAIR DETAILS  
STRUCTURE NO. 016-1000/1001

SHEET NO. SA30 OF SA40 SHEETS

|                           |             |        |                    |           |
|---------------------------|-------------|--------|--------------------|-----------|
| F.A.P. RTE.               | SECTION     | COUNTY | TOTAL SHEETS       | SHEET NO. |
| 372                       | 2013-038B-R | COOK   | 821                | 278       |
|                           |             |        | CONTRACT NO. 60J16 |           |
| ILLINOIS FED. AID PROJECT |             |        |                    |           |

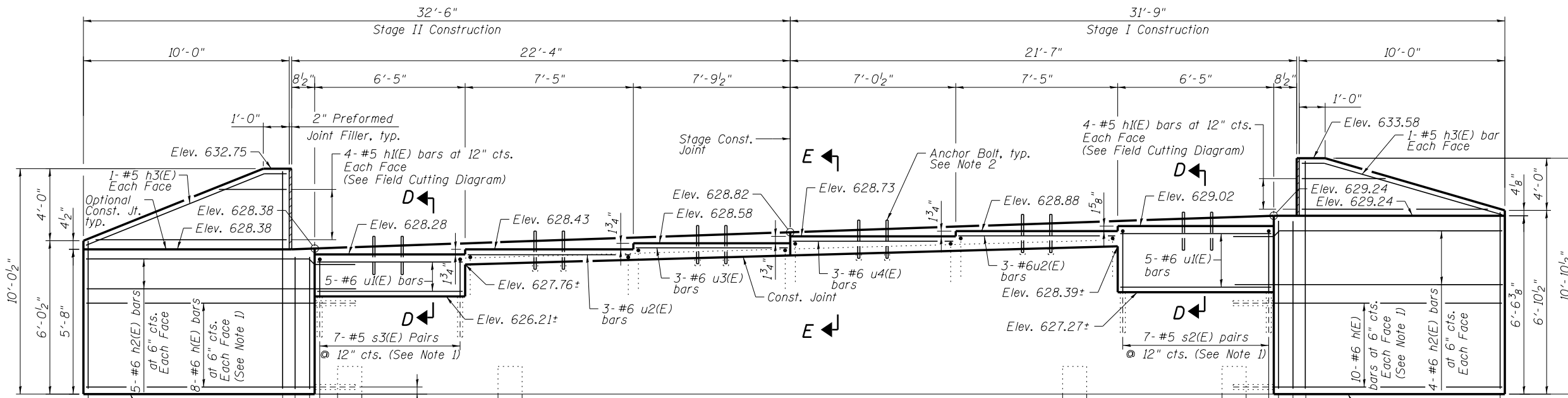

**ELEVATION - SN 016-1000**  
(Looking North)

**MIN. BAR LAP**  
#6 bar = 3'-6"

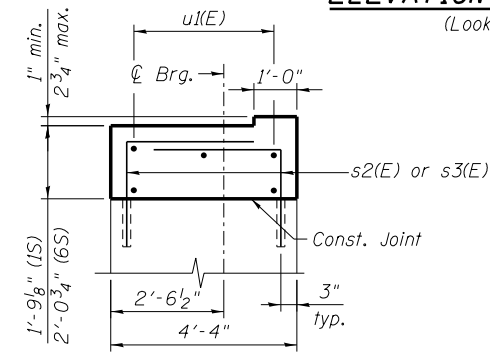

**SECTION D-D**

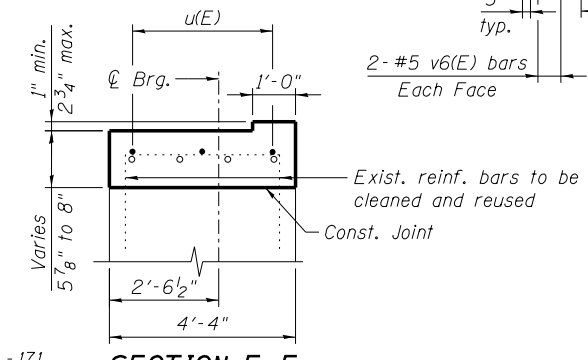

**SECTION E-E**

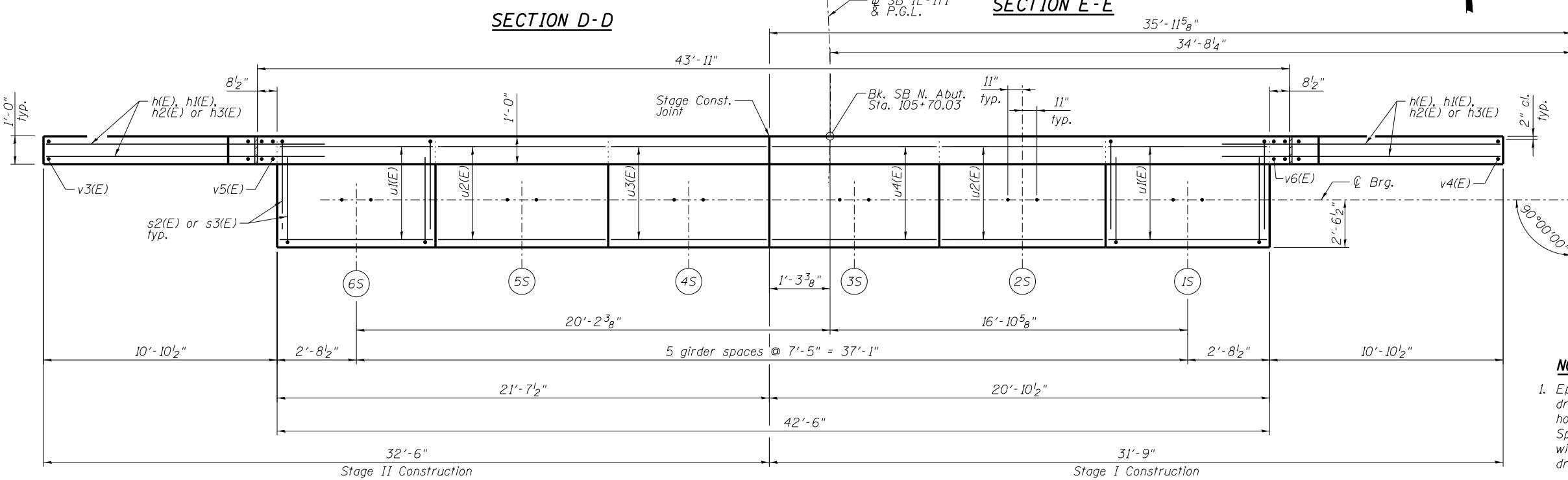
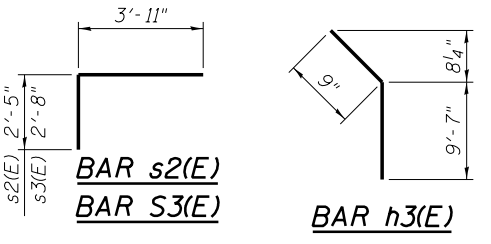

**TOP VIEW - SN 016-1000**

**BILL OF MATERIAL**

| Bar                                | No.     | Size | Length  | Shape |
|------------------------------------|---------|------|---------|-------|
| h(E)                               | 36      | #6   | 11'-7"  | —     |
| h1(E)                              | 16      | #5   | 10'-8"  | —     |
| h2(E)                              | 18      | #6   | 14'-2"  | —     |
| h3(E)                              | 4       | #5   | 10'-4"  | —     |
| s2(E)                              | 14      | #5   | 6'-4"   | ┌     |
| s3(E)                              | 14      | #5   | 6'-7"   | ┌     |
| u1(E)                              | 10      | #6   | 6'-1"   | —     |
| u2(E)                              | 6       | #6   | 7'-1"   | —     |
| u3(E)                              | 3       | #6   | 7'-5"   | —     |
| u4(E)                              | 3       | #6   | 6'-8"   | —     |
| v3(E)                              | 22      | #5   | 16'-0"  | —     |
| v4(E)                              | 22      | #5   | 16'-10" | —     |
| v5(E)                              | 4       | #5   | 5'-2"   | —     |
| v6(E)                              | 4       | #5   | 5'-11"  | —     |
| Concrete Structures                | Cu. Yd. | 13.5 |         |       |
| Reinforcement Bars, Epoxy Coated   | Pound   | 2440 |         |       |
| Geocomposite Wall Drain            | Sq. Yd. | 26   |         |       |
| Pipe Underdrains for Structures 4" | Foot    | 68   |         |       |

**FIELD CUTTING DIAGRAM**  
Order h1(E), v3(E) & v4(E) full length. Cut as shown and use remainder of bars in opposite face.

- NOTES:**
- Epoxy grout s2(E) & s3(E) bars in 9" min. drilled holes and h(E) bars in 9" min. drilled holes according to Section 584 of the Standard Specifications. Drilling and grouting included with "Concrete Structures". h(E) bars to be drilled and placed inside the existing vertical bars.
  - See Sheet SA28 for anchor bolt details.

**benesch**  
engineers · scientists · planners  
Alfred Benesch & Company  
205 North Michigan Avenue, Suite 2400  
Chicago, Illinois 60601  
312-565-0450 Job No. 10093

|                                   |                     |                |           |
|-----------------------------------|---------------------|----------------|-----------|
| FILE NAME =                       | USER NAME = jsurber | DESIGNED - RMM | REVISED - |
| 0161000_60J16_031_NAbutMod_SB.dgn |                     | CHECKED - DJM  | REVISED - |
|                                   |                     | DRAWN - MAK    | REVISED - |
|                                   |                     | CHECKED - RMM  | REVISED - |
|                                   |                     |                |           |

**STATE OF ILLINOIS**  
**DEPARTMENT OF TRANSPORTATION**

**NORTH ABUTMENT MODIFICATION DETAILS**  
**STRUCTURE NO. 016-1000/1001**

SHEET NO. SA31 OF SA40 SHEETS

| F.A.P. R.T.E.      | SECTION     | COUNTY | TOTAL SHEETS              | SHEET NO. |
|--------------------|-------------|--------|---------------------------|-----------|
| 372                | 2013-038B-R | COOK   | 821                       | 279       |
| CONTRACT NO. 60J16 |             |        | ILLINOIS FED. AID PROJECT |           |

X:\1000005\10093\Eng\_Docs\_Phase\_1\11\SN\_016-1000\_1001\_1st\_Ave\_over\_47th\_St\_Final\0161000\_60J16\_031\_NAbutMod\_SB.dgn

2:00:34 PM

7/29/2014

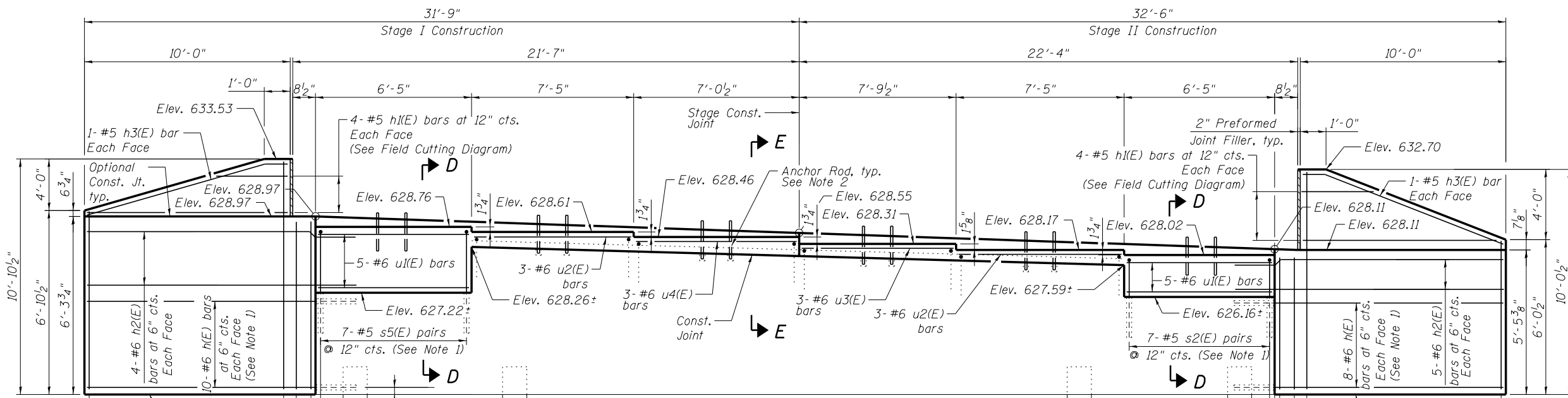

**ELEVATION - SN 016-1000**  
(Looking South)

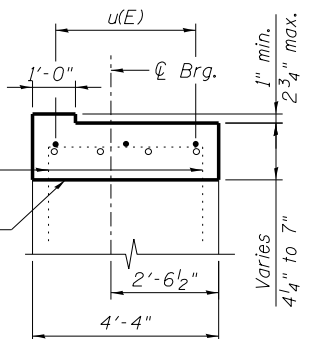
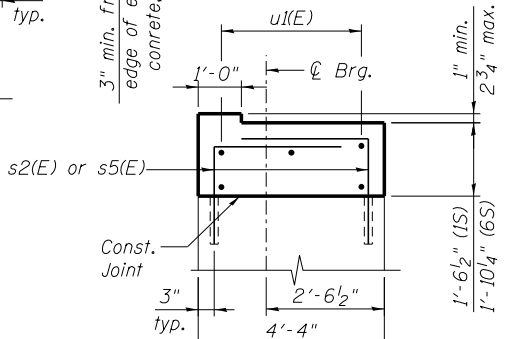

**MIN. BAR LAP**  
#6 bar = 3'-6"

**BILL OF MATERIAL**

| Bar                                | No. | Size    | Length  | Shape |
|------------------------------------|-----|---------|---------|-------|
| h1(E)                              | 36  | #6      | 11'-7"  |       |
| h1(E)                              | 16  | #5      | 10'-8"  |       |
| h2(E)                              | 18  | #6      | 14'-2"  |       |
| h3(E)                              | 4   | #5      | 10'-4"  |       |
| s2(E)                              | 14  | #5      | 6'-4"   |       |
| s5(E)                              | 14  | #5      | 6'-1"   |       |
| u1(E)                              | 10  | #6      | 6'-1"   |       |
| u2(E)                              | 6   | #6      | 7'-1"   |       |
| u3(E)                              | 3   | #6      | 7'-5"   |       |
| u4(E)                              | 3   | #6      | 6'-8"   |       |
| v3(E)                              | 22  | #5      | 16'-0"  |       |
| v4(E)                              | 22  | #5      | 16'-10" |       |
| v5(E)                              | 4   | #5      | 5'-1"   |       |
| v6(E)                              | 4   | #5      | 5'-10"  |       |
| Concrete Structures                |     | Cu. Yd. | 13.5    |       |
| Reinforcement Bars, Epoxy Coated   |     | Pound   | 2435    |       |
| Geocomposite Wall Drain            |     | Sq. Yd. | 26      |       |
| Pipe Underdrains for Structures 4" |     | Foot    | 69      |       |

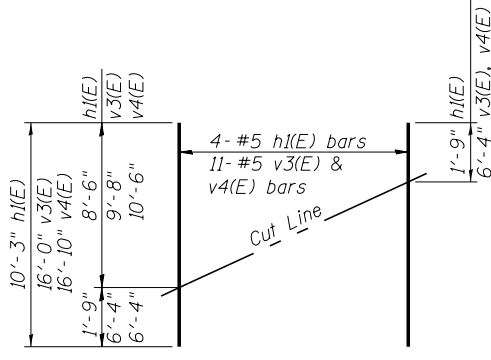
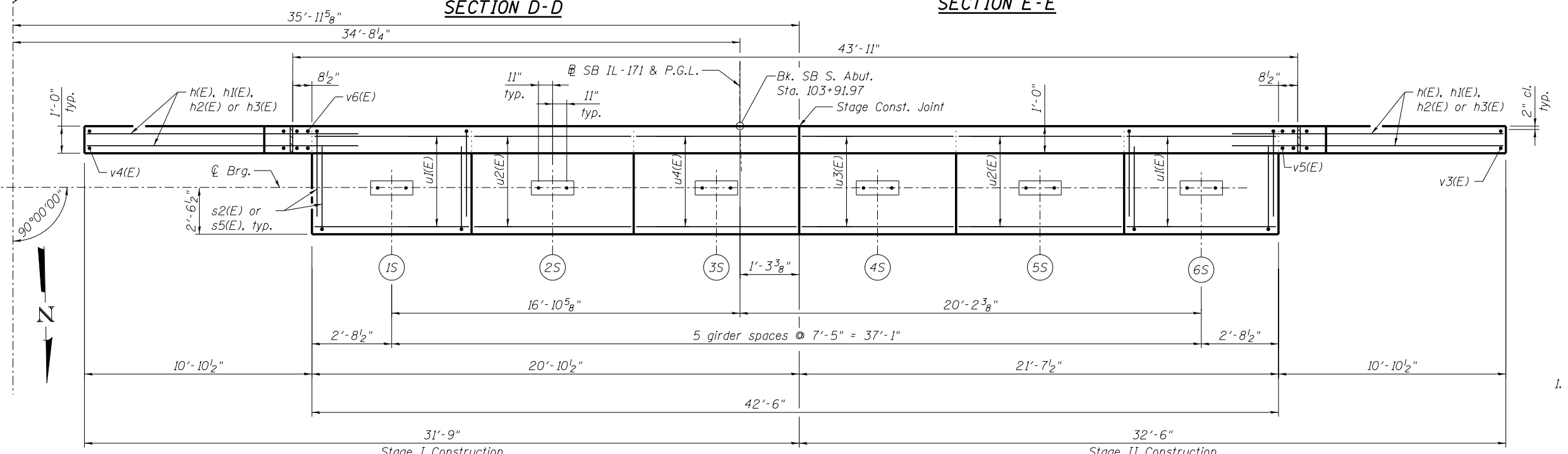
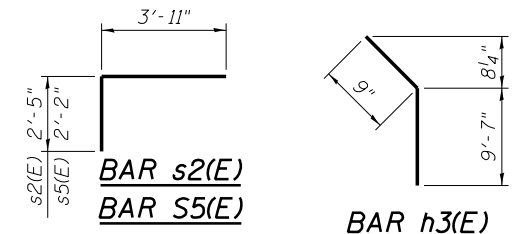

**FIELD CUTTING DIAGRAM**

Order h1(E), v3(E) & v4(E) full length. Cut as shown and use remainder of bars in opposite face.

**NOTES:**

- Epoxy grout s2(E) & s5(E) bars in 9" min. drilled holes and h(E) bars in 9" min. drilled holes according to Section 584 of the Standard Specifications. Drilling and grouting included with "Concrete Structures". h(E) bars to be drilled and placed inside the existing vertical bars.
- See Sheet SA28 for anchor rod details.

**benesch**  
engineers · scientists · planners

Alfred Benesch & Company  
205 North Michigan Avenue, Suite 2400  
Chicago, Illinois 60601  
312-565-0450 Job No. 10093

|                                    |                     |                |           |
|------------------------------------|---------------------|----------------|-----------|
| FILE NAME =                        | USER NAME = jsurber | DESIGNED - RMM | REVISED - |
| 0161000_60J16_032_SAAbutMod_SB.dgn |                     | CHECKED - DJM  | REVISED - |
|                                    |                     | DRAWN - MAK    | REVISED - |
|                                    |                     | CHECKED - RMM  | REVISED - |
|                                    |                     |                |           |

**STATE OF ILLINOIS**  
**DEPARTMENT OF TRANSPORTATION**

**SOUTH ABUTMENT MODIFICATION DETAILS**  
**STRUCTURE NO. 016-1000/1001**

| F.A.P. RTE.               | SECTION     | COUNTY | TOTAL SHEETS | SHEET NO. |
|---------------------------|-------------|--------|--------------|-----------|
| 372                       | 2013-038B-R | COOK   | 821          | 280       |
| CONTRACT NO. 60J16        |             |        |              |           |
| ILLINOIS FED. AID PROJECT |             |        |              |           |

SHEET NO. SA32 OF SA40 SHEETS

X:\100005\10093\Eng\_Docs\_Phase\_1\11\SN\_016-1000\_1001\_1st\_Ave\_over\_47th\_St\Final\0161000\_60J16\_032\_SAAbutMod\_SB.dgn 2:00:35 PM 7/29/2014

Remove Existing Wingwall to Existing Const. Jt.

**TYPICAL WINGWALL ELEVATION**

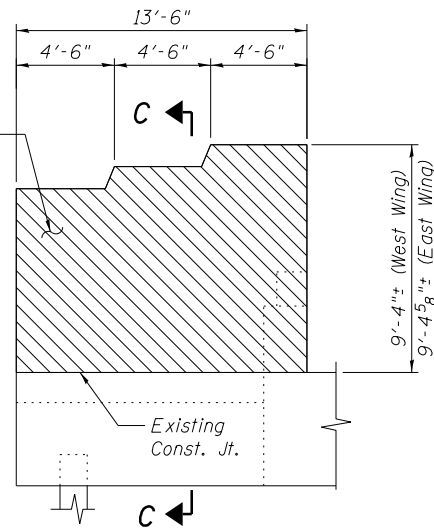

**ELEVATION - SN 016-1001**

(Looking North)

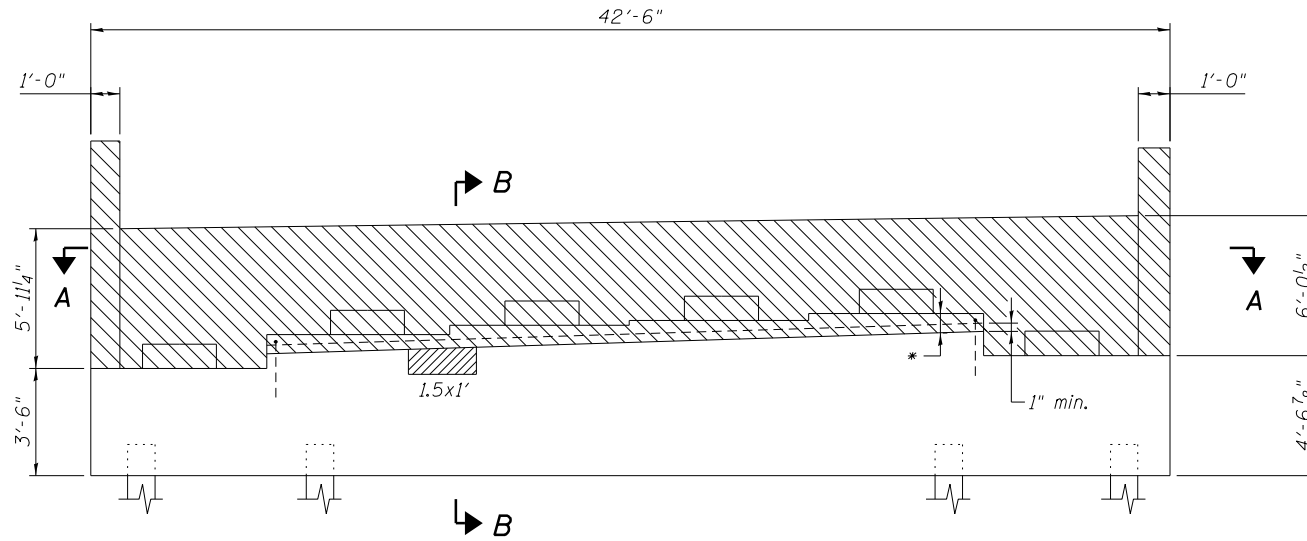

\* 3" below abutment seat or 1" min. below existing transverse reinforcement; whichever is greater. Existing exposed reinforcement shall be cleaned and incorporated into the new construction. Cost included with concrete removal.

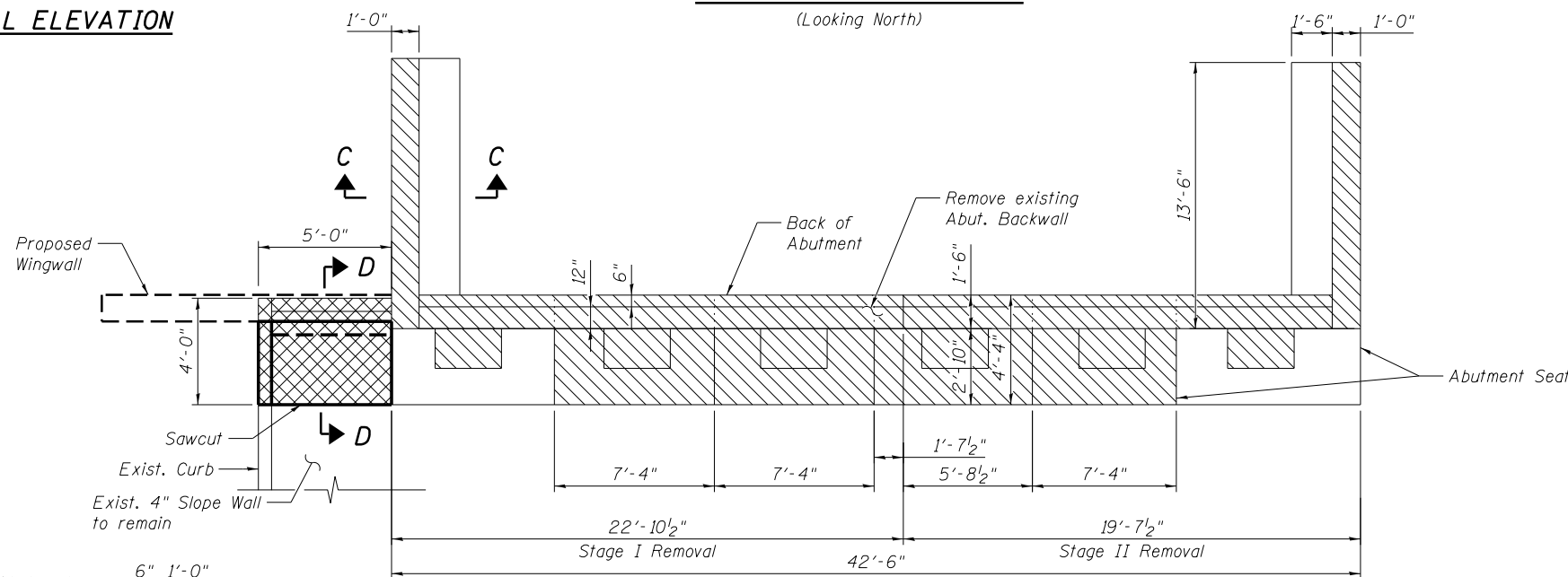

**SECTION A-A**

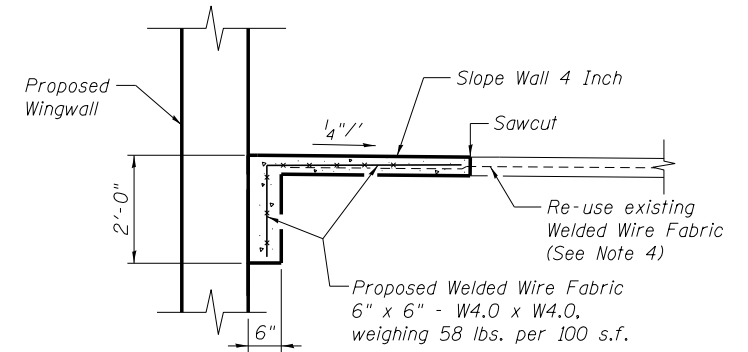

**SECTION D-D**

**LEGEND**

- Concrete Removal
- Structural Repair of Concrete (Depth Equal to or Less Than 5 Inches)
- Slope Wall Removal (See Note 4)

**NOTES:**

1. Actual quantities of repairs shall be approved by the Engineer.
2. Existing vertical reinforcement shall be cut flush with the the concrete removal surface, except as noted. Cost included with "Concrete Removal".
3. See Sheet SA2 for Pay Limits of "Structure Excavation".
4. Replace Slope Wall in-kind up to front face of Proposed Wingwall. Re-use existing Welded Wire Fabric. Cost to re-use fabric is included with "Slope Wall 4 inch".

**BILL OF MATERIAL**

| ITEM   | UNIT    | TOTAL |
|--|---------|-------|
| Structure Excavation   | Cu. Yd. | 98    |
| Granular Backfill for Structures                                     | Cu. Yd. | 96    |
| Concrete Removal   | Cu. Yd. | 26.2  |
| Structural Repair of Concrete (Depth Equal to or Less Than 5 Inches) | Sq. Ft. | 2     |
| Slope Wall Removal   | Sq. Yd. | 2     |
| Slope Wall 4 inch  | Sq. Yd. | 2     |



Alfred Benesch & Company  
205 North Michigan Avenue, Suite 2400  
Chicago, Illinois 60601  
312-565-0450 Job No. 10093

|                                      |                        |                |           |
|--------------------------------------|------------------------|----------------|-----------|
| FILE NAME =                          | USER NAME = tjenicke   | DESIGNED - RMM | REVISED - |
| 0161000_60J16_033_NAbutRepair_NB.dgn | PLOT SCALE =           | CHECKED - DJM  | REVISED - |
|                                      | PLOT DATE = 12/20/2012 | DRAWN - MAK    | REVISED - |
|                                      |                        | CHECKED - RMM  | REVISED - |

**STATE OF ILLINOIS  
DEPARTMENT OF TRANSPORTATION**

**NORTH ABUTMENT CONCRETE REMOVAL AND REPAIR DETAILS  
STRUCTURE NO. 016-1000/1001**

SHEET NO. SA33 OF SA40 SHEETS

|                    |             |        |                           |           |
|--------------------|-------------|--------|---------------------------|-----------|
| F.A.P. RTE.        | SECTION     | COUNTY | TOTAL SHEETS              | SHEET NO. |
| 372                | 2013-038B-R | COOK   | 821                       | 281       |
| CONTRACT NO. 60J16 |             |        | ILLINOIS FED. AID PROJECT |           |

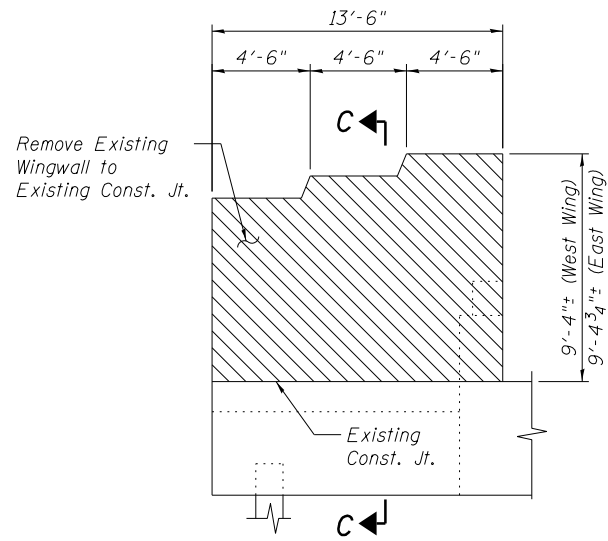

TYPICAL WINGWALL ELEVATION

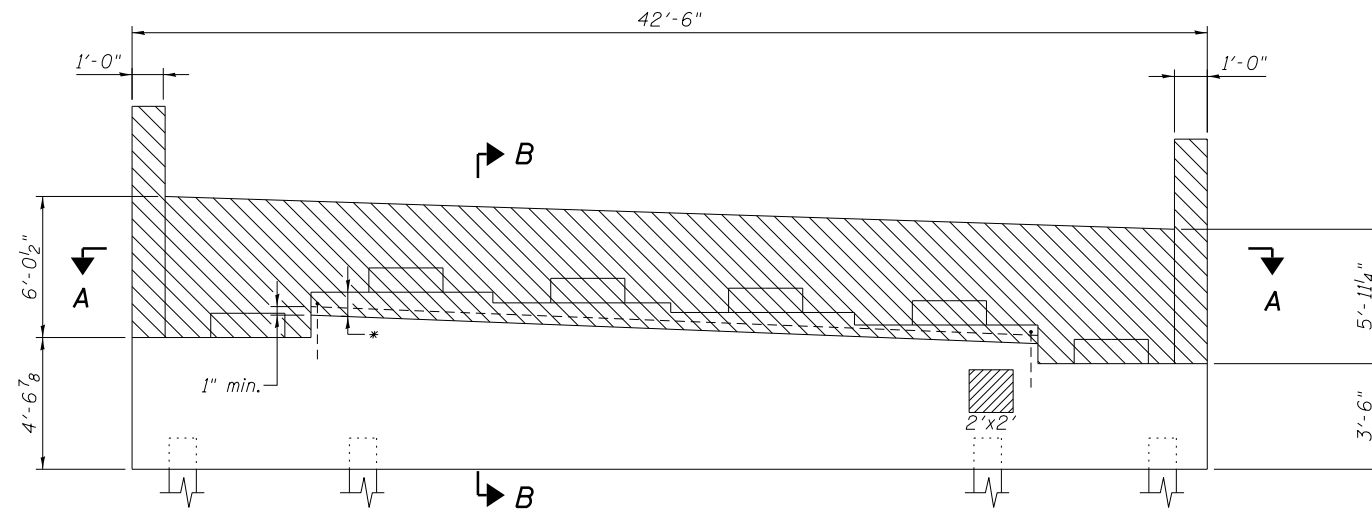

ELEVATION - SN 016-1001  
(Looking South)

\* 4" below abutment seat or 1" min. below existing transverse reinforcement; whichever is greater. Existing exposed reinforcement shall be cleaned and incorporated into the new construction. Cost included with concrete removal.

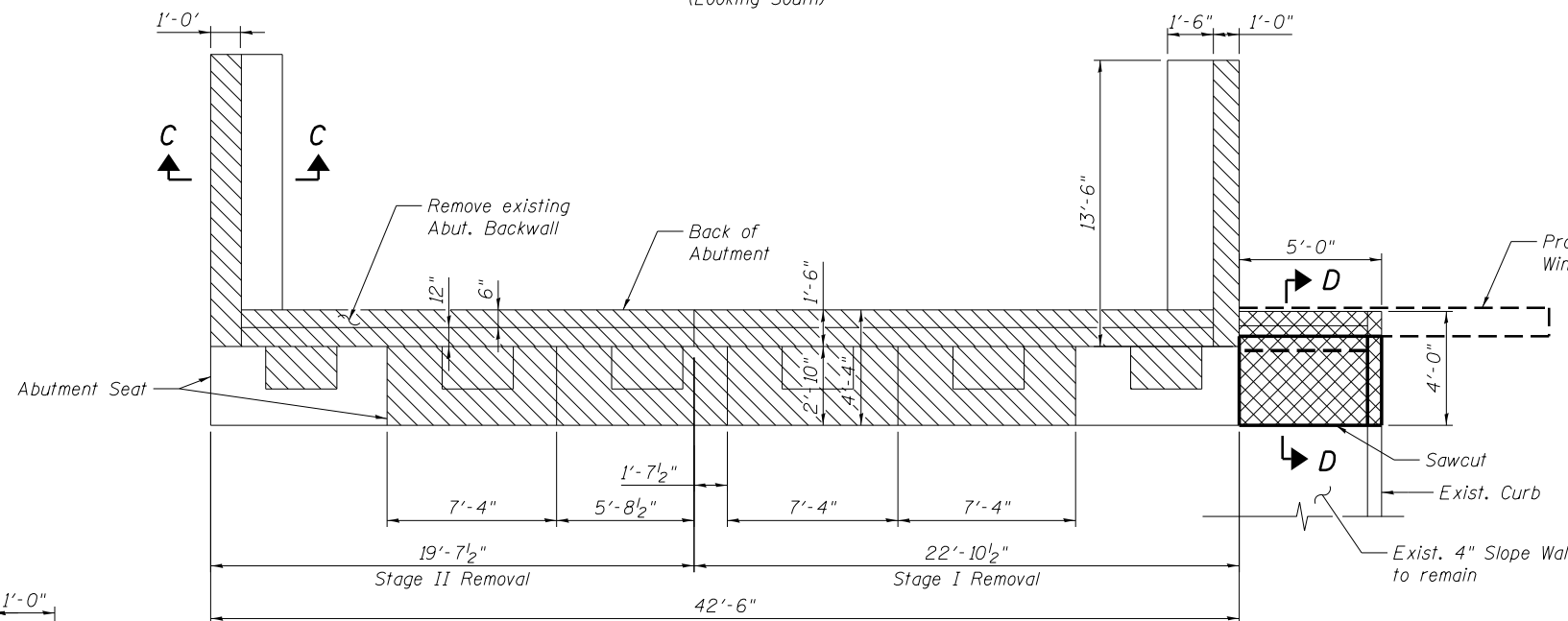

SECTION A-A

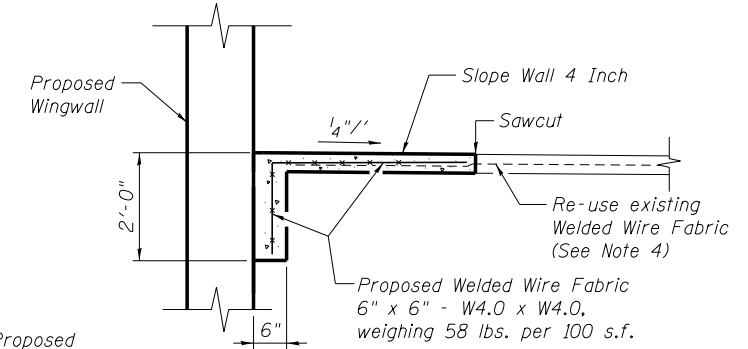

SECTION D-D

LEGEND

- Concrete Removal
- Structural Repair of Concrete (Depth Equal to or Less Than 5 Inches)
- Slope Wall Removal (See Note 4)

NOTES:

1. Actual quantities of repairs shall be approved by the Engineer.
2. Existing vertical reinforcement shall be cut flush with the concrete removal surface, except as noted. Cost included with "Concrete Removal".
3. See Sheet SA2 for Pay Limits of "Structure Excavation".
4. Replace Slope Wall in-kind up to front face of Proposed Wingwall. Re-use existing Welded Wire Fabric. Cost to re-use fabric is included with "Slope Wall 4 inch".

BILL OF MATERIAL

| ITEM   | UNIT    | TOTAL |
|--|---------|-------|
| Structure Excavation   | Cu. Yd. | 98    |
| Granular Backfill for Structures                                     | Cu. Yd. | 96    |
| Concrete Removal   | Cu. Yd. | 26.2  |
| Structural Repair of Concrete (Depth Equal to or Less Than 5 Inches) | Sq. Ft. | 4     |
| Slope Wall Removal   | Sq. Yd. | 2     |
| Slope Wall 4 inch  | Sq. Yd. | 2     |

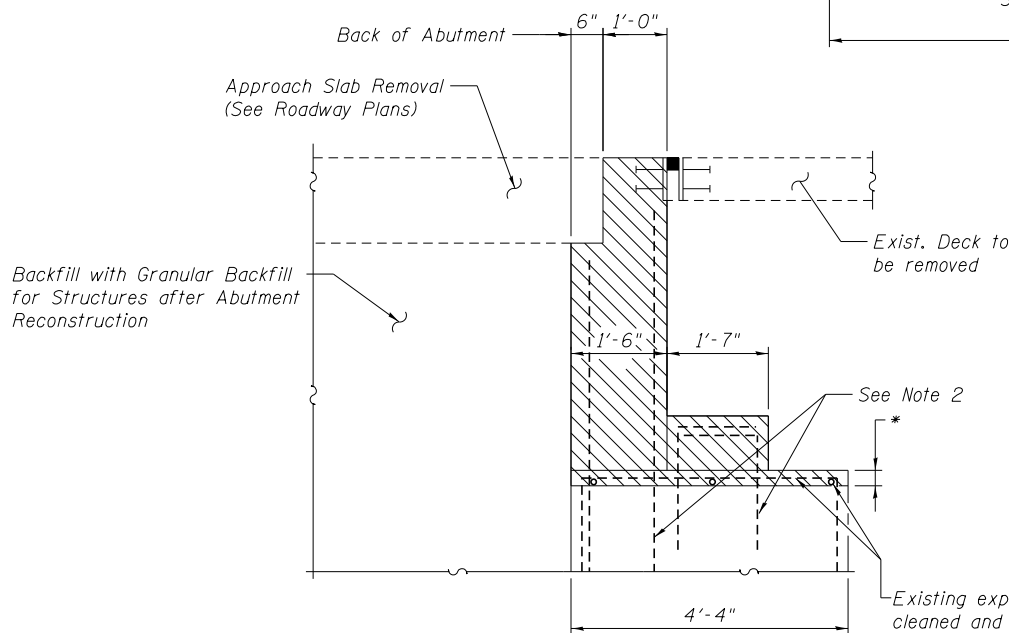

SECTION B-B

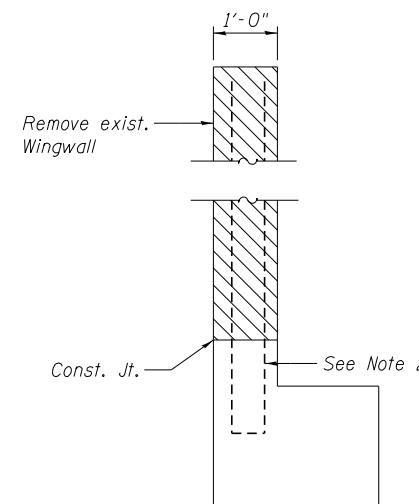

SECTION C-C

**benesch**  
engineers · scientists · planners

Alfred Benesch & Company  
205 North Michigan Avenue, Suite 2400  
Chicago, Illinois 60601  
312-565-0450 Job No. 10093

|                                      |                        |                |           |
|--------------------------------------|------------------------|----------------|-----------|
| FILE NAME =                          | USER NAME = tjenicke   | DESIGNED - RMM | REVISED - |
| 0161000_60J16_034_SAbutRepair_NB.dgn | PLOT SCALE =           | CHECKED - DJM  | REVISED - |
|                                      | PLOT DATE = 12/20/2012 | DRAWN - MAK    | REVISED - |
|                                      |                        | CHECKED - RMM  | REVISED - |

STATE OF ILLINOIS  
DEPARTMENT OF TRANSPORTATION

SOUTH ABUTMENT CONCRETE REMOVAL AND REPAIR DETAILS  
STRUCTURE NO. 016-1000/1001

SHEET NO. SA34 OF SA40 SHEETS

|                           |             |        |                    |           |
|---------------------------|-------------|--------|--------------------|-----------|
| F.A.P. RTE.               | SECTION     | COUNTY | TOTAL SHEETS       | SHEET NO. |
| 372                       | 2013-038B-R | COOK   | 821                | 282       |
|                           |             |        | CONTRACT NO. 60J16 |           |
| ILLINOIS FED. AID PROJECT |             |        |                    |           |

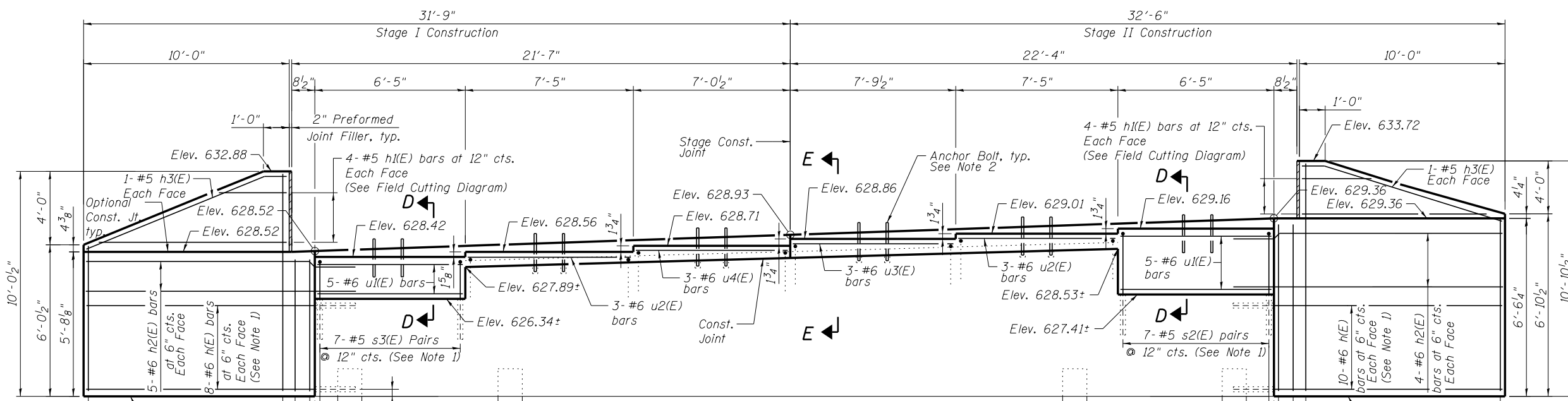

**ELEVATION - SN 016-1001**  
(Looking North)

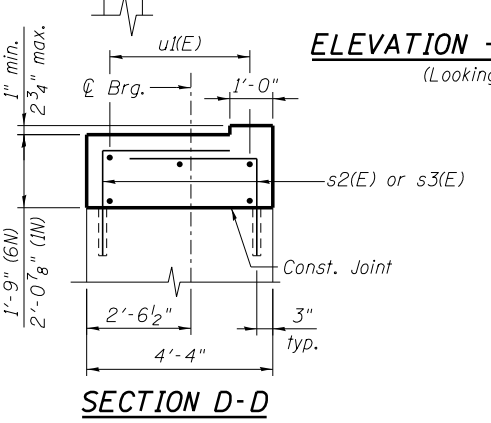

**SECTION D-D**

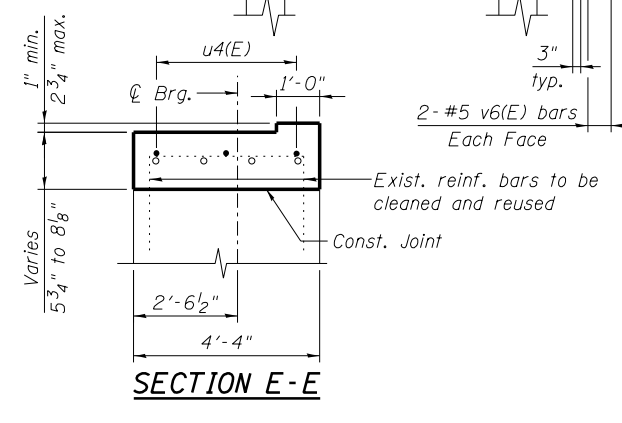

**SECTION E-E**

**MIN. BAR LAP**  
#6 bar = 3'-6"

**BILL OF MATERIAL**

| Bar                                | No. | Size    | Length  | Shape |
|------------------------------------|-----|---------|---------|-------|
| h(E)                               | 36  | #6      | 11'-7"  | —     |
| h1(E)                              | 16  | #5      | 10'-8"  | —     |
| h2(E)                              | 18  | #6      | 14'-2"  | —     |
| h3(E)                              | 4   | #5      | 10'-4"  | —     |
| s2(E)                              | 14  | #5      | 6'-4"   | └     |
| s3(E)                              | 14  | #5      | 6'-7"   | └     |
| u1(E)                              | 10  | #6      | 6'-1"   | —     |
| u2(E)                              | 6   | #6      | 7'-1"   | —     |
| u3(E)                              | 3   | #6      | 7'-5"   | —     |
| u4(E)                              | 3   | #6      | 6'-8"   | —     |
| v3(E)                              | 22  | #5      | 16'-0"  | —     |
| v4(E)                              | 22  | #5      | 16'-10" | —     |
| v5(E)                              | 4   | #5      | 5'-2"   | —     |
| v6(E)                              | 4   | #5      | 5'-11"  | —     |
| Concrete Structures                |     | Cu. Yd. | 13.5    |       |
| Reinforcement Bars, Epoxy Coated   |     | Pound   | 2440    |       |
| Geocomposite Wall Drain            |     | Sq. Yd. | 26      |       |
| Pipe Underdrains for Structures 4" |     | Foot    | 68      |       |

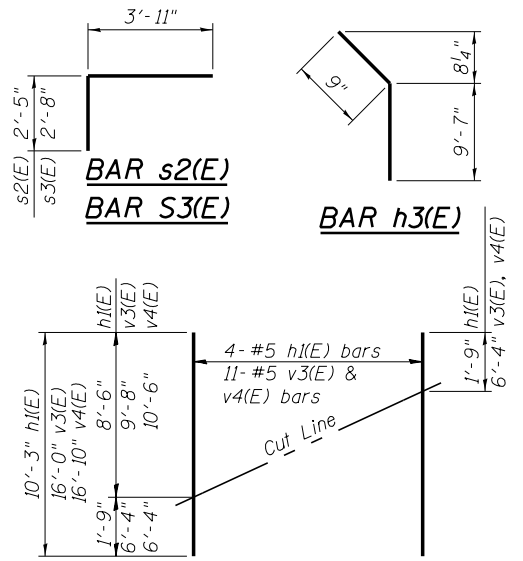

**FIELD CUTTING DIAGRAM**

Order h1(E), v3(E) & v4(E) full length. Cut as shown and use remainder of bars in opposite face.

- NOTES:**
- Epoxy grout s2(E) & s3(E) bars in 9" min. drilled holes and h(E) bars in 9" min. drilled holes according to Section 584 of the Standard Specifications. Drilling and grouting included with "Concrete Structures". h(E) bars to be drilled and placed inside the existing vertical bars.
  - See Sheet SA28 for anchor bolt details.

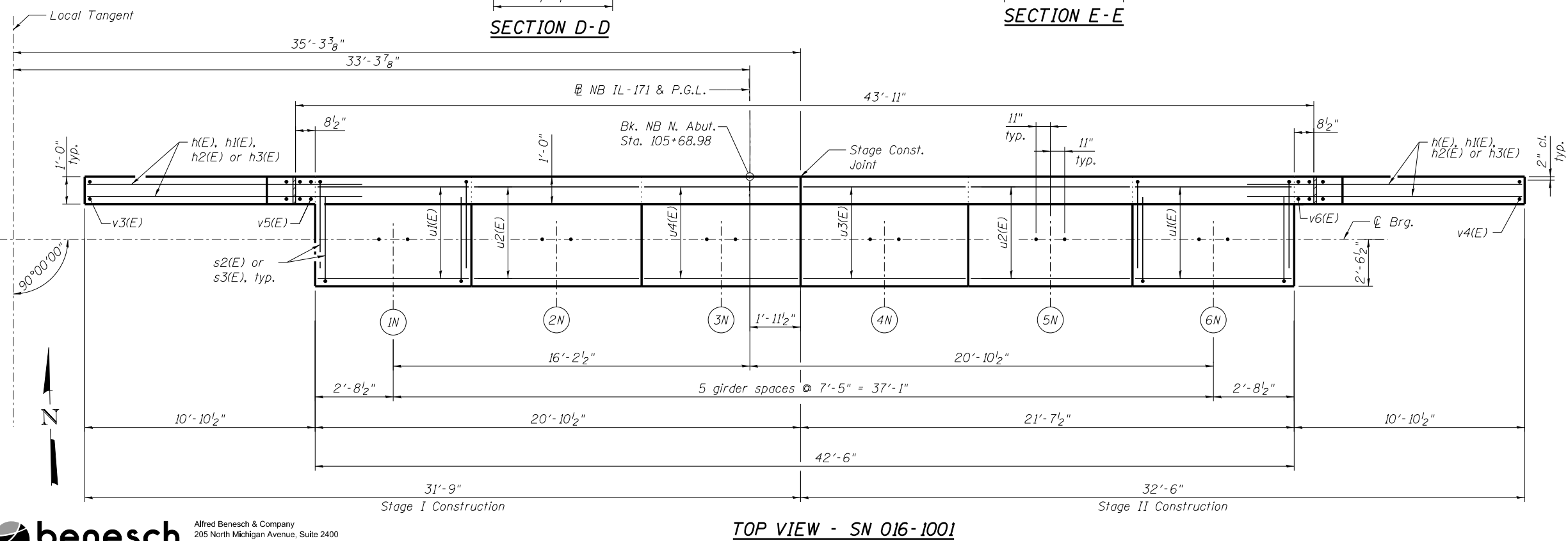

**TOP VIEW - SN 016-1001**

**benesch**  
engineers · scientists · planners

Alfred Benesch & Company  
205 North Michigan Avenue, Suite 2400  
Chicago, Illinois 60601  
312-565-0450 Job No. 10093

|                                   |                     |                |           |
|-----------------------------------|---------------------|----------------|-----------|
| FILE NAME =                       | USER NAME = jsurber | DESIGNED - RMM | REVISED - |
| 0161000_60J16_035_NAButMod_NB.dgn |                     | CHECKED - DJM  | REVISED - |
|                                   |                     | DRAWN - MAK    | REVISED - |
|                                   |                     | CHECKED - RMM  | REVISED - |
|                                   |                     |                |           |

**STATE OF ILLINOIS**  
**DEPARTMENT OF TRANSPORTATION**

**NORTH ABUTMENT MODIFICATION DETAILS**  
**STRUCTURE NO. 016-1000/1001**

SHEET NO. SA35 OF SA40 SHEETS

| F.A.P. RT.                | SECTION     | COUNTY | TOTAL SHEETS | SHEET NO. |
|---------------------------|-------------|--------|--------------|-----------|
| 372                       | 2013-038B-R | COOK   | 821          | 283       |
| CONTRACT NO. 60J16        |             |        |              |           |
| ILLINOIS FED. AID PROJECT |             |        |              |           |

X:\1000005\10093\Eng\_Docs\_Phase\_1\11\SN\_016\_1000\_1001\_1st\_Ave\_over\_47th\_St\Final\0161000\_60J16\_035\_NAButMod\_NB.dgn 2:00:36 PM 7/29/2014

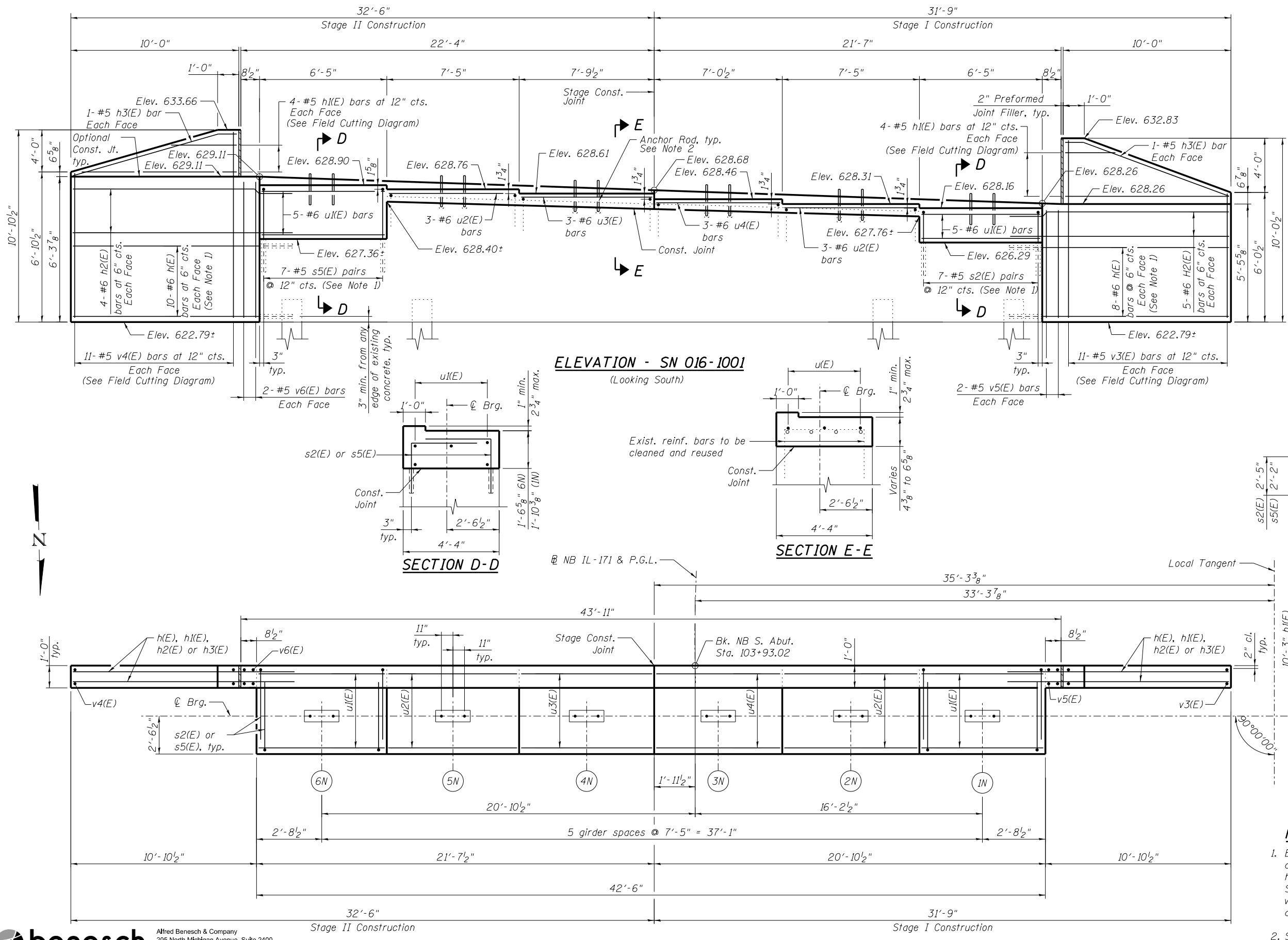

**BILL OF MATERIAL**

| Bar                                | No. | Size    | Length  | Shape |
|------------------------------------|-----|---------|---------|-------|
| h(E)                               | 36  | #6      | 11'-7"  | ---   |
| h2(E)                              | 16  | #5      | 10'-8"  | ---   |
| h3(E)                              | 4   | #6      | 14'-2"  | ---   |
| h3(E)                              | 4   | #5      | 10'-4"  | ---   |
| s2(E)                              | 14  | #5      | 6'-4"   | └┘    |
| s5(E)                              | 14  | #5      | 6'-1"   | └┘    |
| u(E)                               | 10  | #6      | 6'-1"   | ---   |
| u2(E)                              | 6   | #6      | 7'-1"   | ---   |
| u3(E)                              | 3   | #6      | 7'-5"   | ---   |
| u4(E)                              | 3   | #6      | 6'-8"   | ---   |
| v3(E)                              | 22  | #5      | 16'-0"  | ---   |
| v4(E)                              | 22  | #5      | 16'-10" | ---   |
| v5(E)                              | 4   | #5      | 5'-1"   | ---   |
| v6(E)                              | 4   | #5      | 5'-10"  | ---   |
| Concrete Structures                |     | Cu. Yd. | 13.5    |       |
| Reinforcement Bars, Epoxy Coated   |     | Pound   | 2435    |       |
| Geocomposite Wall Drain            |     | Sq. Yd. | 26      |       |
| Pipe Underdrains for Structures 4" |     | Foot    | 69      |       |

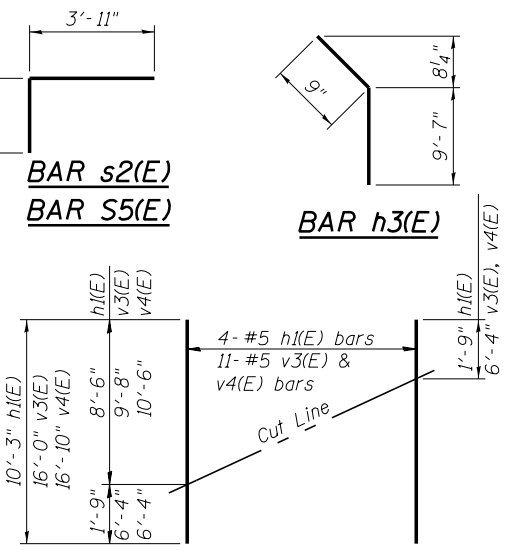

**FIELD CUTTING DIAGRAM**

Order h(E), v3(E) & v4(E) full length. Cut as shown and use remainder of bars in opposite face.

**MIN. BAR LAP**

#6 bar = 3'-6"

**NOTES:**

- Epoxy grout s2(E) & s5(E) bars in 9" min. drilled holes and h(E) bars in 9" min. drilled holes according to Section 584 of the Standard Specifications. Drilling and grouting included with "Concrete Structures". h(E) bars to be drilled and placed inside the existing vertical bars.
- See Sheet SA28 for anchor rod details.

**benesch**  
engineers · scientists · planners  
Alfred Benesch & Company  
205 North Michigan Avenue, Suite 2400  
Chicago, Illinois 60601  
312-565-0450 Job No. 10093

|                                   |                     |                |           |
|-----------------------------------|---------------------|----------------|-----------|
| FILE NAME =                       | USER NAME = jsurber | DESIGNED - RMM | REVISED - |
| 0161000.60J16.036.SAbutMod.NB.dgn |                     | CHECKED - DJM  | REVISED - |
|                                   |                     | DRAWN - MAK    | REVISED - |
|                                   |                     | CHECKED - RMM  | REVISED - |
|                                   |                     |                |           |

**TOP VIEW - SN 016-1001**

**STATE OF ILLINOIS**  
**DEPARTMENT OF TRANSPORTATION**

**SOUTH ABUTMENT MODIFICATION DETAILS**  
**STRUCTURE NO. 016-1000/1001**

SHEET NO. SA36 OF SA40 SHEETS

| F.A.P. RTE.               | SECTION     | COUNTY | TOTAL SHEETS | SHEET NO. |
|---------------------------|-------------|--------|--------------|-----------|
| 372                       | 2013-038B-R | COOK   | 821          | 284       |
| CONTRACT NO. 60J16        |             |        |              |           |
| ILLINOIS FED. AID PROJECT |             |        |              |           |



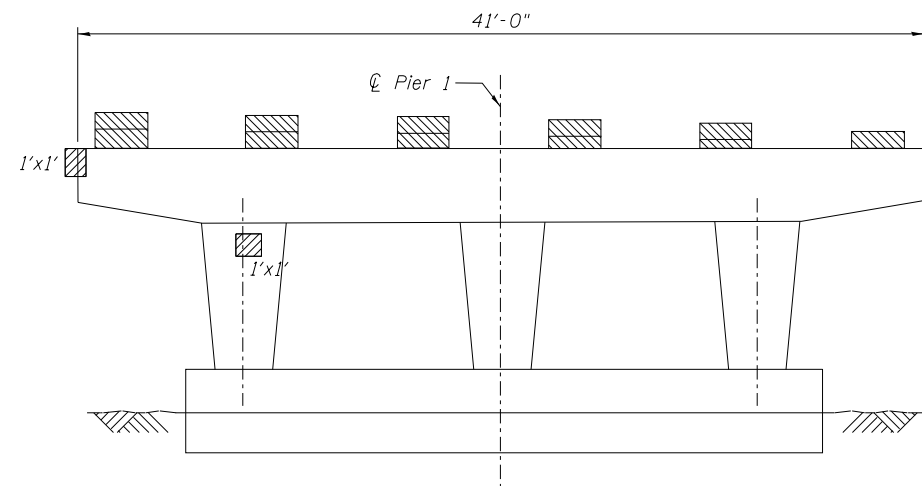

**PIER 1 - SN 016-1000**  
Looking South

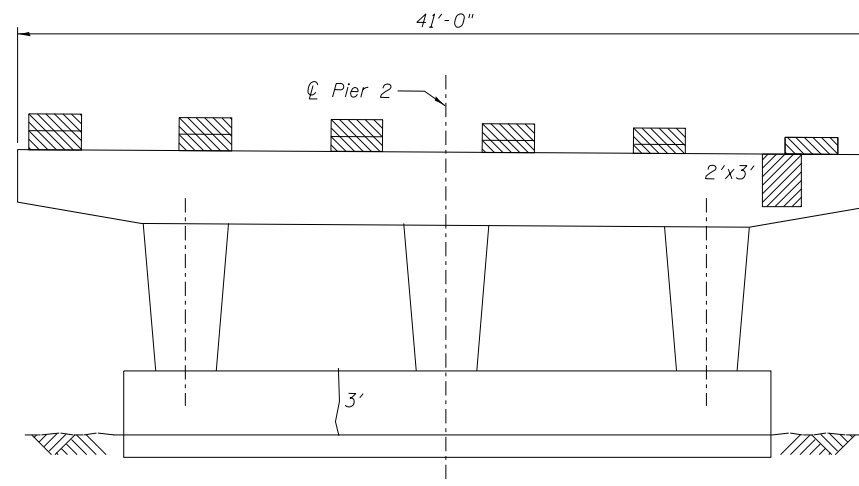

**PIER 2 - SN 016-1000**  
Looking South

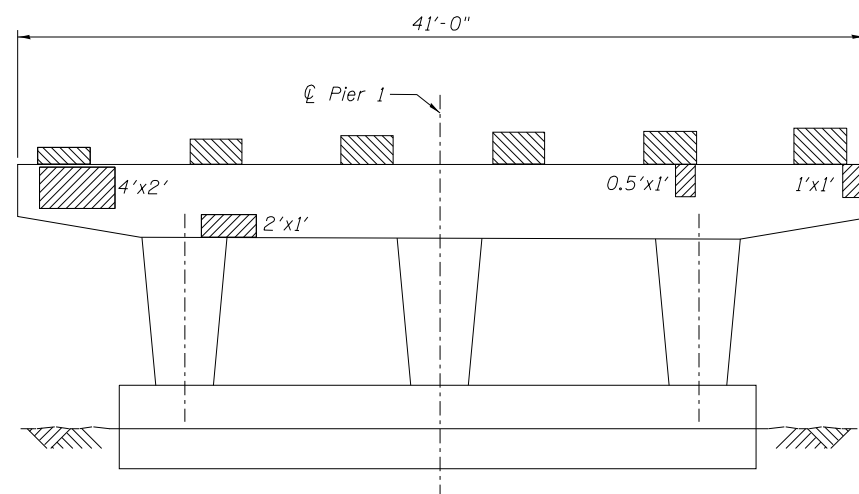

**PIER 1 - SN 016-1000**  
Looking North

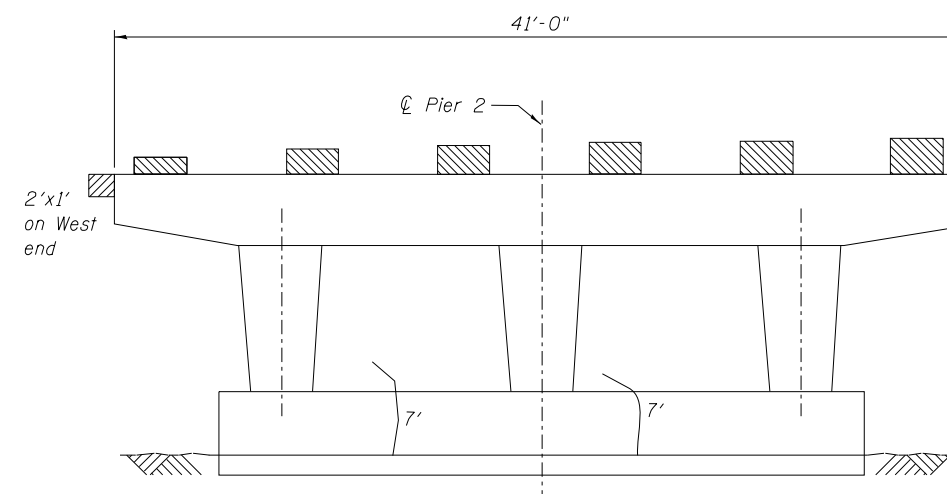

**PIER 2 - SN 016-1000**  
Looking North

**NOTES:**

- Actual quantities of repairs shall be approved by the Engineer.
- Existing reinforcement shall be cleaned and incorporated into the new construction. Cost included with "Concrete Removal".

**LEGEND**

- Concrete Removal
- Structural Repair of Concrete (Depth Equal to or Less Than 5 Inches)
- Epoxy Crack Injection

**BILL OF MATERIAL**

| ITEM   | UNIT    | TOTAL |
|--|---------|-------|
| Concrete Removal   | Cu. Yd. | 2.6   |
| Structural Repair of Concrete (Depth Equal to or Less Than 5 Inches) | Sq. Ft. | 22    |
| Epoxy Crack Injection  | Foot    | 17    |

**benesch**  
engineers · scientists · planners  
Alfred Benesch & Company  
205 North Michigan Avenue, Suite 2400  
Chicago, Illinois 60601  
312-565-0450 Job No. 10093

|                                     |                        |                |           |
|-------------------------------------|------------------------|----------------|-----------|
| FILE NAME =                         | USER NAME = tjenicke   | DESIGNED - RMM | REVISED - |
|                                     |                        | CHECKED - DJM  | REVISED - |
|                                     |                        | DRAWN - FSM    | REVISED - |
|                                     |                        | CHECKED - RMM  | REVISED - |
| 0161000_60J16_037_pierrepair_SB.dgn | PLOT SCALE =           |                |           |
|                                     | PLOT DATE = 12/20/2012 |                |           |

**STATE OF ILLINOIS**  
**DEPARTMENT OF TRANSPORTATION**

**PIER CONCRETE REMOVAL AND REPAIR DETAILS**  
**STRUCTURE NO. 016-1000/1001**

SHEET NO. SA37 OF SA40 SHEETS

|                    |             |        |                           |           |
|--------------------|-------------|--------|---------------------------|-----------|
| F.A.P. RTE.        | SECTION     | COUNTY | TOTAL SHEETS              | SHEET NO. |
| 372                | 2013-038B-R | COOK   | 821                       | 285       |
| CONTRACT NO. 60J16 |             |        | ILLINOIS FED. AID PROJECT |           |

X:\1000005\100093\Eng\_Docs\_Phase\_1\1\SN\_016\_1000\_1001\_1st\_Ave\_over\_47th\_St\Final\0161000\_60J16\_037\_pierrepair\_SB.dgn 2:28:25 PM 6/23/2014

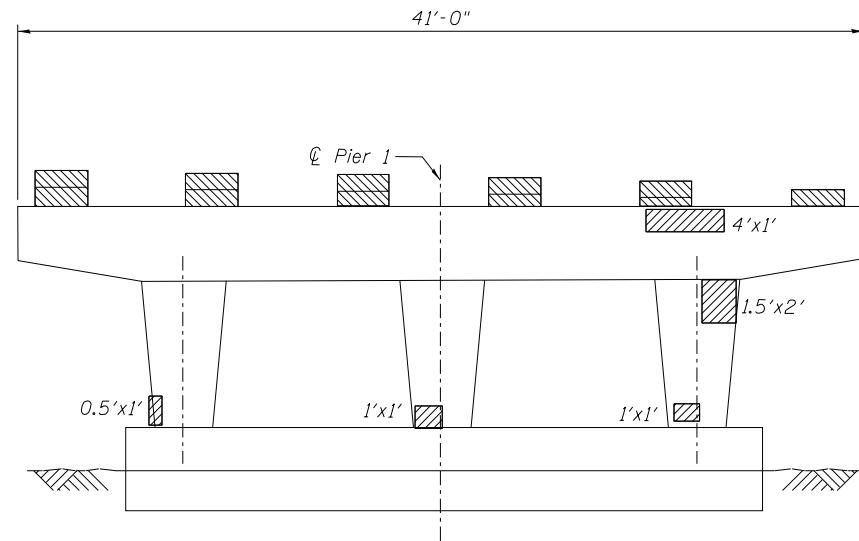

**PIER 1 - SN 016-1001**

Looking South

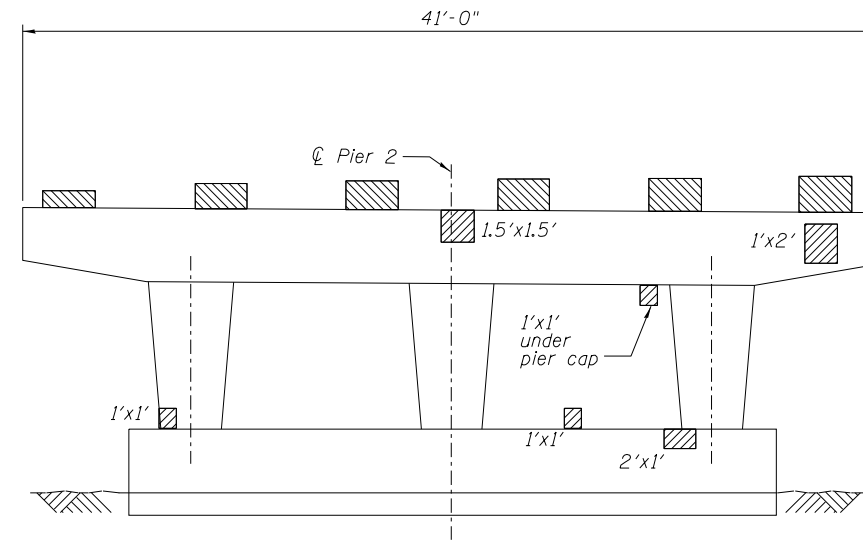

**PIER 2 - SN 016-1001**

Looking South

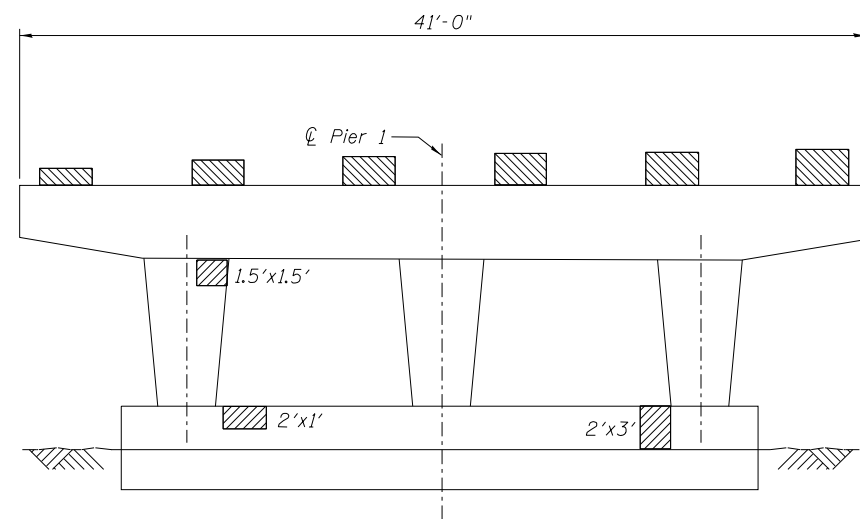

**PIER 1 - SN 016-1001**

Looking North

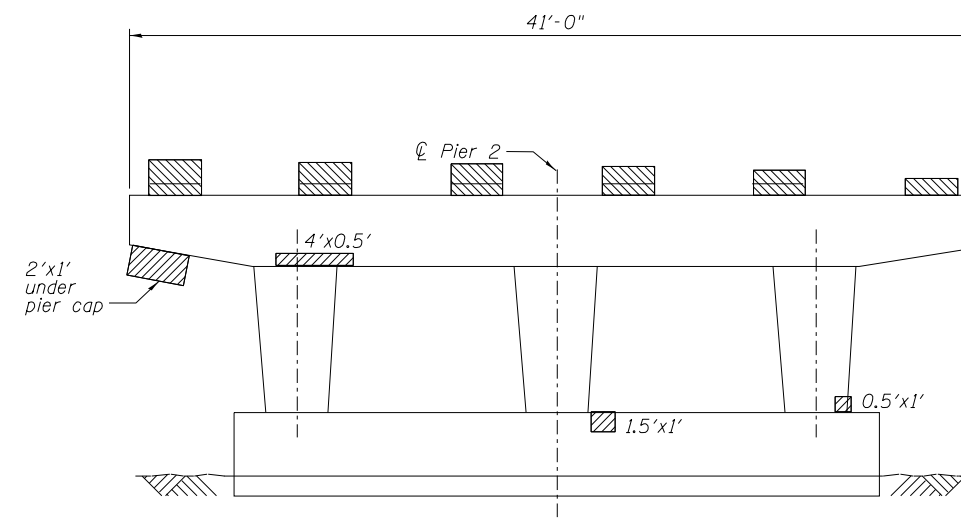

**PIER 2 - SN 016-1001**

Looking North

**NOTES:**

1. Actual quantities of repairs shall be approved by the Engineer.
2. Existing reinforcement shall be cleaned and incorporated into the new construction. Cost included with "Concrete Removal".

**LEGEND**

- Concrete Removal
- Structural Repair of Concrete (Depth Equal to or Less Than 5 Inches)

**BILL OF MATERIAL**

| ITEM   | UNIT    | TOTAL |
|--|---------|-------|
| Concrete Removal   | Cu. Yd. | 2.6   |
| Structural Repair of Concrete (Depth Equal to or Less Than 5 Inches) | Sq. Ft. | 35    |

**benesch**  
engineers · scientists · planners  
Alfred Benesch & Company  
205 North Michigan Avenue, Suite 2400  
Chicago, Illinois 60601  
312-565-0450 Job No. 10093

|                                     |                        |                |           |
|-------------------------------------|------------------------|----------------|-----------|
| FILE NAME =                         | USER NAME = tjenicke   | DESIGNED - RMM | REVISED - |
|                                     |                        | CHECKED - DJM  | REVISED - |
| 0161000_60J16_038_pierrepair_NB.dgn | PLOT SCALE =           | DRAWN - FSM    | REVISED - |
|                                     | PLOT DATE = 12/20/2012 | CHECKED - RMM  | REVISED - |

**STATE OF ILLINOIS  
DEPARTMENT OF TRANSPORTATION**

**PIER CONCRETE REMOVAL AND REPAIR DETAILS  
STRUCTURE NO. 016-1000/1001**

SHEET NO. SA38 OF SA40 SHEETS

|                           |             |        |                    |           |
|---------------------------|-------------|--------|--------------------|-----------|
| F.A.P. RTE.               | SECTION     | COUNTY | TOTAL SHEETS       | SHEET NO. |
| 372                       | 2013-038B-R | COOK   | 821                | 286       |
|                           |             |        | CONTRACT NO. 60J16 |           |
| ILLINOIS FED. AID PROJECT |             |        |                    |           |

**FOUR PIERS  
BILL OF MATERIAL**

| Bar                                 | No. | Size | Length  | Shape  |
|-------------------------------------|-----|------|---------|--------|
| h4(E)                               | 24  | #5   | 19'-9"  | —      |
| h5(E)                               | 24  | #5   | 21'-6"  | —      |
| h6(E)                               | 16  | #8   | 19'-9"  | —      |
| h7(E)                               | 16  | #8   | 21'-6"  | —      |
| s4(E)                               | 72  | #5   | 7'-2"   | □      |
| s6(E)                               | 208 | #6   | 7'-8"   | □      |
| s7(E)                               | 208 | #6   | 8'-2"   | □      |
| v7(E)                               | 80  | #5   | 5'-8"   | □      |
| v8(E)                               | 80  | #5   | 7'-2"   | □      |
| v9(E)                               | 176 | #6   | 4'-10"  | □      |
| v10(E)                              | 176 | #6   | 5'-2"   | □      |
| Concrete Structures                 |     |      | Cu. Yd. | 40.7   |
| Reinforcement Bars,<br>Epoxy Coated |     |      | Pound   | 12,000 |

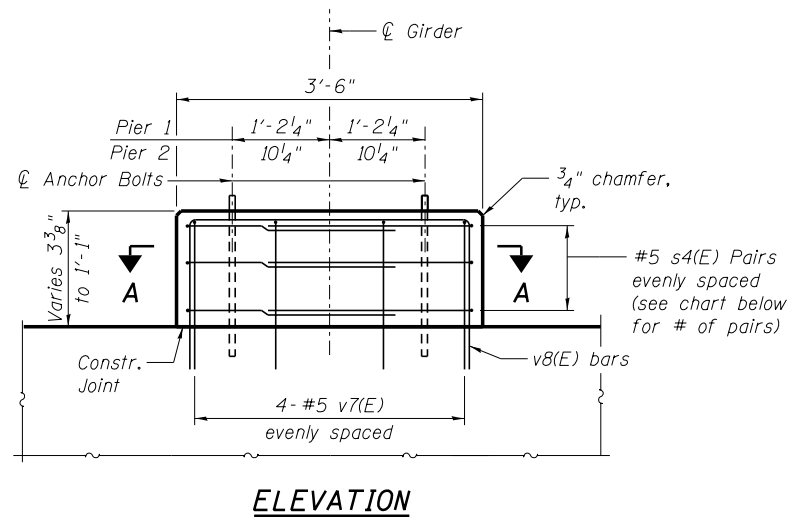

**ELEVATION**

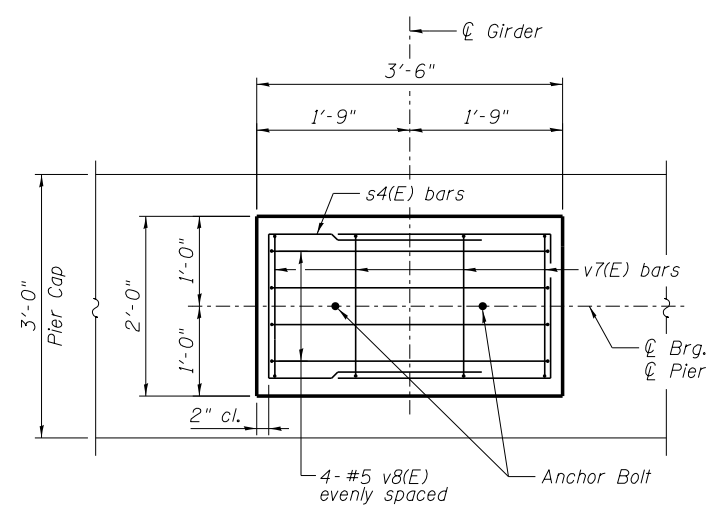

**SECTION A-A**

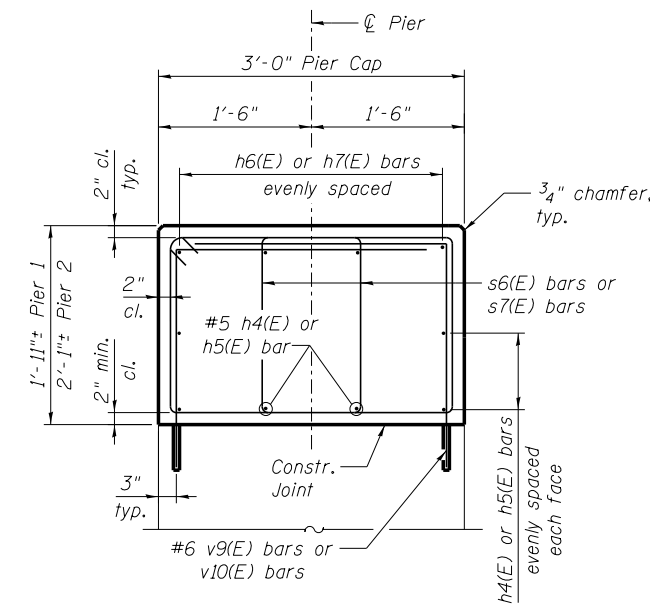

**SECTION B-B**

**TYPICAL CONCRETE EXTENSIONS FOR BEARINGS**

| Piers 1 & 2 Pedestals | # of s4(E) Pairs |
|-----------------------|------------------|
| 1S                    | 3                |
| 2S                    | 2                |
| 3S                    | 2                |
| 4S                    | 1                |
| 5S                    | 1                |
| 6S                    | 0                |
| 1N                    | 0                |
| 2N                    | 1                |
| 3N                    | 1                |
| 4N                    | 2                |
| 5N                    | 2                |
| 6N                    | 3                |

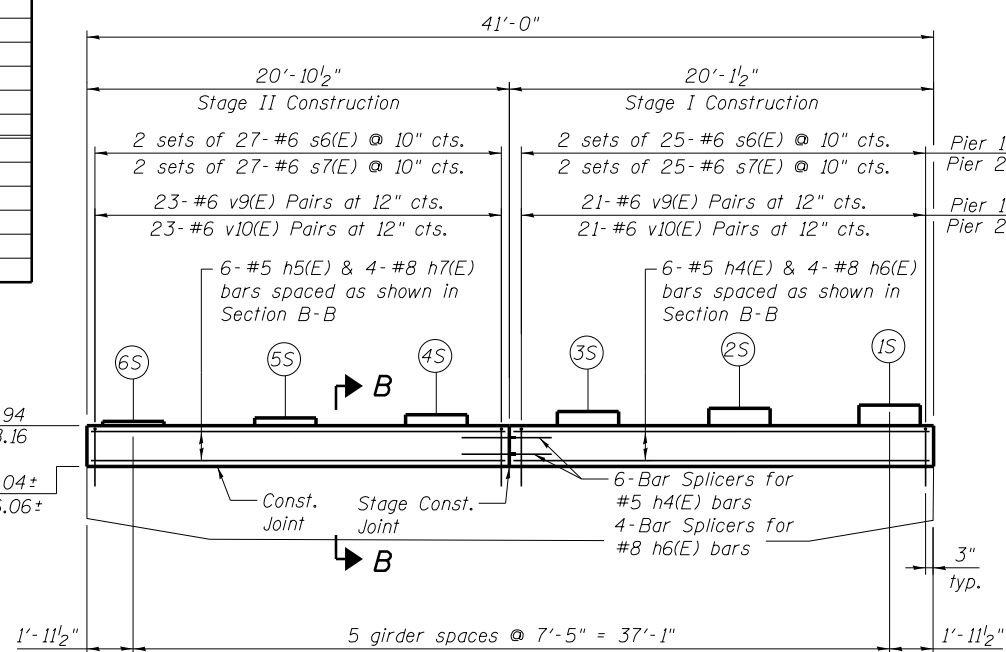

**PIER 1 & 2 SB  
(Looking North)**

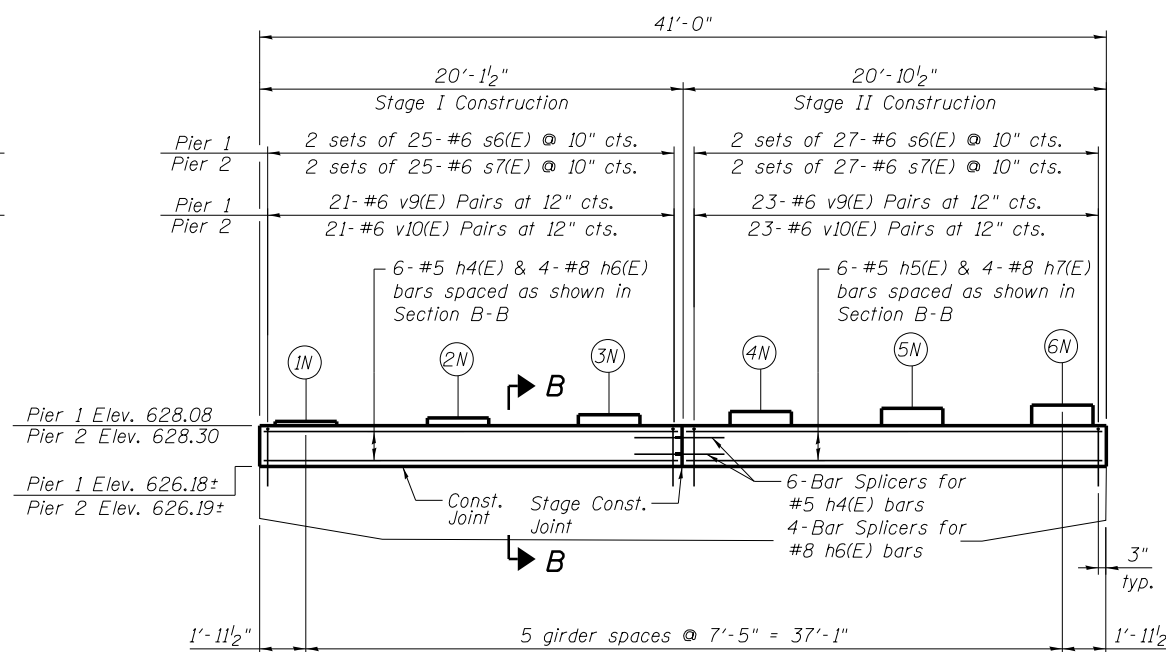

**PIER 1 & 2 NB  
(Looking North)**

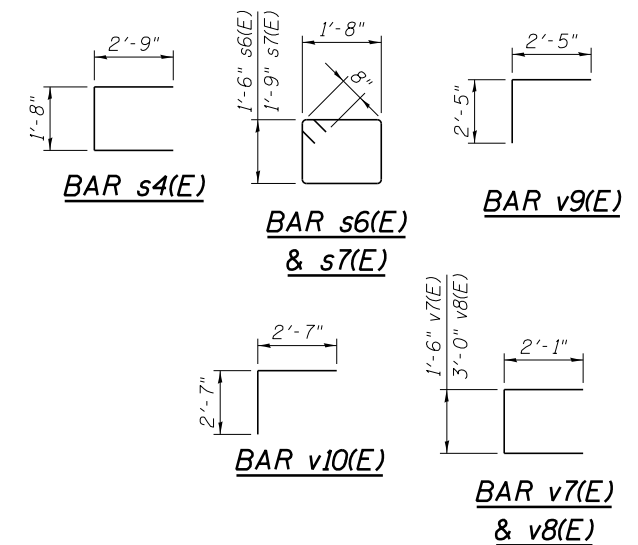

**PEDESTAL ELEVATIONS**

| Girder No. | Pier 1 | Pier 2 |
|------------|--------|--------|
| 1S         | 628.96 | 629.24 |
| 2S         | 628.81 | 629.09 |
| 3S         | 628.66 | 628.94 |
| 4S         | 628.51 | 628.79 |
| 5S         | 628.36 | 628.64 |
| 6S         | 628.22 | 628.49 |
| 1N         | 628.36 | 628.63 |
| 2N         | 628.50 | 628.78 |
| 3N         | 628.65 | 628.93 |
| 4N         | 628.80 | 629.07 |
| 5N         | 628.95 | 629.22 |
| 6N         | 629.10 | 629.37 |

**NOTES:**

- Epoxy grout v9(E) and v10(E) bars in 9" min. drilled holes according to Section 584 of the Standard Specifications. Cost of drilling and grouting included with "Concrete Structures".
- See Sheet SA40 for Bar Splicer Details.
- Reinforcement not to be provided in pedestals at Girders 6S & 1N.
- Space reinforcement to miss anchor bolts.

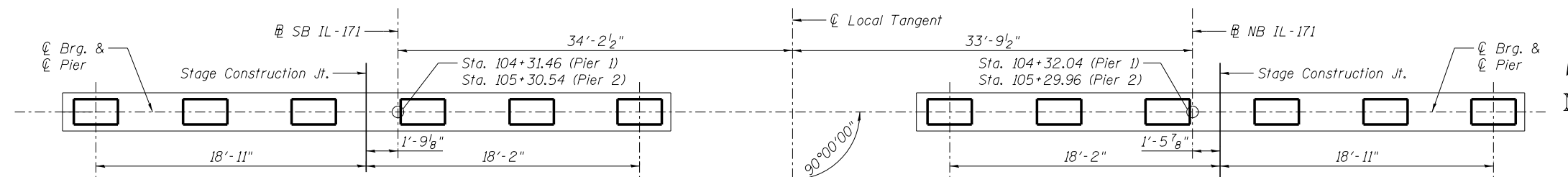

**PLAN - PIER 1 & 2 SB**

**PLAN - PIER 1 & 2 NB**

| FILE NAME :                          | USER NAME : | DESIGNED : | REVISIONS : |
|--------------------------------------|-------------|------------|-------------|
| 0161000_60J16_039_bear-ingenxten.dgn | jsurber     | RMM        |             |
|                                      |             | DJM        |             |
|                                      |             | FSM        |             |
|                                      |             | RMM        |             |

| F.A.P. RTE.        | SECTION     | COUNTY | TOTAL SHEETS              | SHEET NO. |
|--------------------|-------------|--------|---------------------------|-----------|
| 372                | 2013-038B-R | COOK   | 821                       | 287       |
| CONTRACT NO. 60J16 |             |        | ILLINOIS FED. AID PROJECT |           |

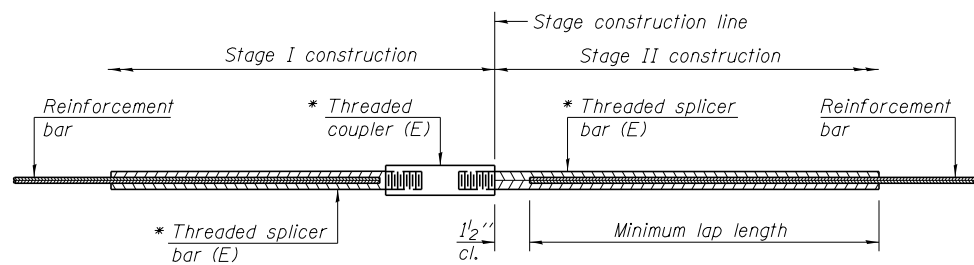

**STANDARD BAR SPLICER ASSEMBLY**

| Minimum Lap Lengths    |         |         |         |         |         |         |
|------------------------|---------|---------|---------|---------|---------|---------|
| Bar size to be spliced | Table 1 | Table 2 | Table 3 | Table 4 | Table 5 | Table 6 |
| 3, 4                   | 1'-5"   | 1'-11"  | 2'-1"   | 2'-4"   | 2'-7"   | 2'-11"  |
| 5                      | 1'-9"   | 2'-5"   | 2'-7"   | 2'-11"  | 3'-3"   | 3'-8"   |
| 6                      | 2'-1"   | 2'-11"  | 3'-1"   | 3'-6"   | 3'-10"  | 4'-5"   |
| 7                      | 2'-9"   | 3'-10"  | 4'-2"   | 4'-8"   | 5'-2"   | 5'-10"  |
| 8                      | 3'-8"   | 5'-1"   | 5'-5"   | 6'-2"   | 6'-9"   | 7'-8"   |
| 9                      | 4'-7"   | 6'-5"   | 6'-10"  | 7'-9"   | 8'-7"   | 9'-8"   |

- Table 1: Black bar, 0.8 Class C
- Table 2: Black bar, Top bar lap, 0.8 Class C
- Table 3: Epoxy bar, 0.8 Class C
- Table 4: Epoxy bar, Top bar lap, 0.8 Class C
- Table 5: Epoxy bar, Class C
- Table 6: Epoxy bar, Top bar top, Class C

Threaded splicer bar length = min. lap length + 1 1/2" + thread length

\* Epoxy not required on Bar Splicer Assembly components used in conjunction with black bars.

| Location         | Bar size | No. assemblies required | Table for minimum lap length |
|------------------|----------|-------------------------|------------------------------|
| Deck             | #5       | 1232                    | Table 5                      |
| Abut. Diaphragm  | #6       | 48                      | Table 4                      |
| Piers 1 & 2      | #5       | 32                      | Table 4                      |
| Piers 1 & 2      | #8       | 16                      | Table 4                      |
| Approach Slab    | #4       | 100                     | Table 4                      |
| Approach Slab    | #5       | 184                     | Table 3                      |
| Approach Footing | #5       | 160                     | Table 3                      |

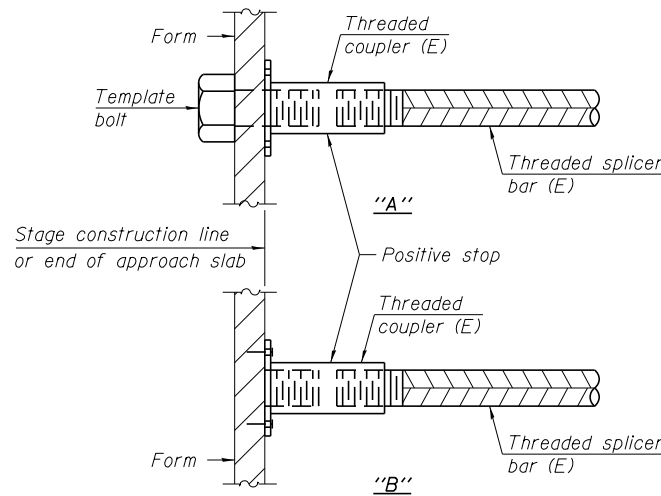

**INSTALLATION AND SETTING METHODS**

"A": Set bar splicer assembly by means of a template bolt.  
 "B": Set bar splicer assembly by nailing to wood forms or cementing to steel forms.  
 (E) : Indicates epoxy coating.

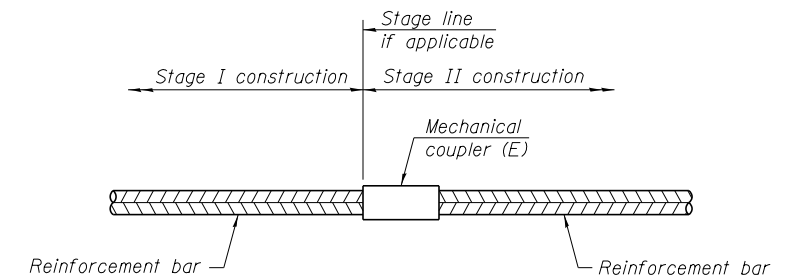

**STANDARD MECHANICAL SPLICER**

| Location | Bar size | No. assemblies required |
|----------|----------|-------------------------|
|          |          |                         |
|          |          |                         |
|          |          |                         |
|          |          |                         |

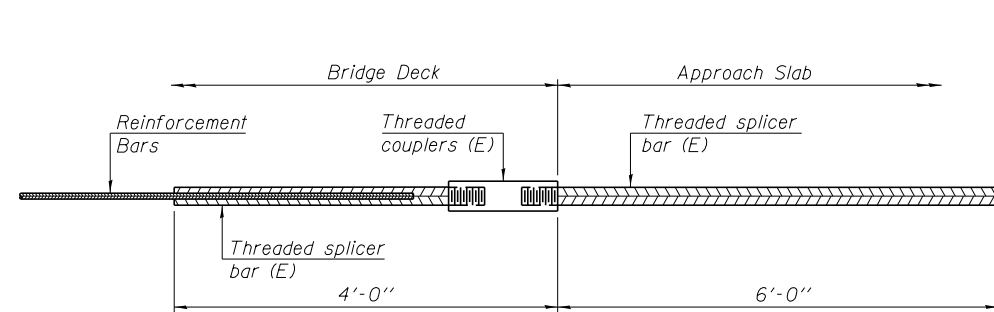

**BAR SPLICER ASSEMBLY FOR #5 BAR ON INTEGRAL OR SEMI-INTEGRAL ABUTMENTS**

No. required =

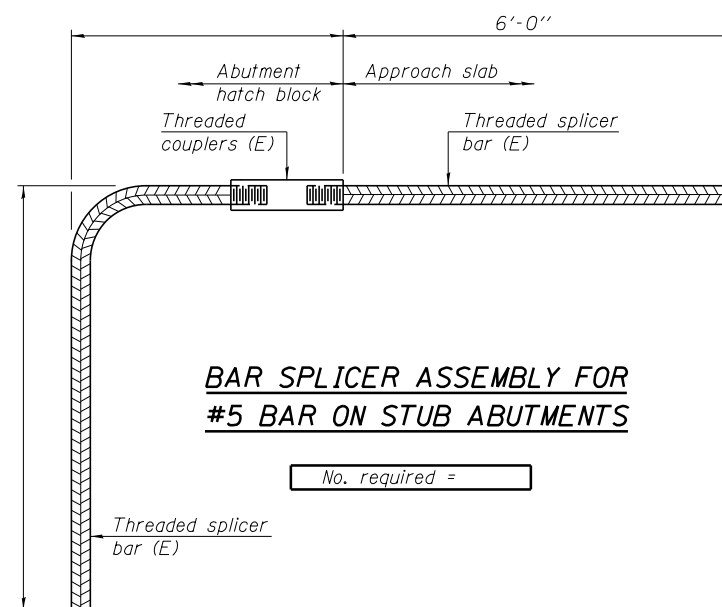

**BAR SPLICER ASSEMBLY FOR #5 BAR ON STUB ABUTMENTS**

No. required =

**NOTES**

Splicer bars shall be deformed with threaded ends and have a minimum 60 ksi yield strength.  
 All reinforcement shall be lapped and tied to the splicer bars.  
 Bar splicer assemblies shall be epoxy coated according to the requirements for reinforcement bars. See Section 508 of the Standard Specifications.  
 See approved list of bar splicer assemblies and mechanical splicers for alternatives.

X:\1000005\100093\Eng\_Docs\_Phase\_1\1\SN\_016\_1000\_1001\_1st\_Ave\_over\_47th\_St\Final\0161000\_60J16\_040\_splicer-assy.dgn 6/23/2014 2:28:27 PM

Concrete floor shall be finished with a 6" thick  
concrete 1905 concrete W. base, 5" Ave 100' North of E  
47th St. Elev. 632.29

STATE OF ILLINOIS  
DEPARTMENT OF PUBLIC WORKS & BUILDINGS  
DIVISION OF HIGHWAYS

Minimum embankment which must  
be constructed prior to construction  
of bridge elements in the embankments.

| SHEET NO.        | SECTION     | COUNTY | TOTAL SHEETS | SHEET NO. | SHEET NO. |
|------------------|-------------|--------|--------------|-----------|-----------|
| 133              | 0102-683HBK | COOK   | 149          | 101       | 23 SHEETS |
| PROJ. U-383 (31) |             |        |              |           |           |

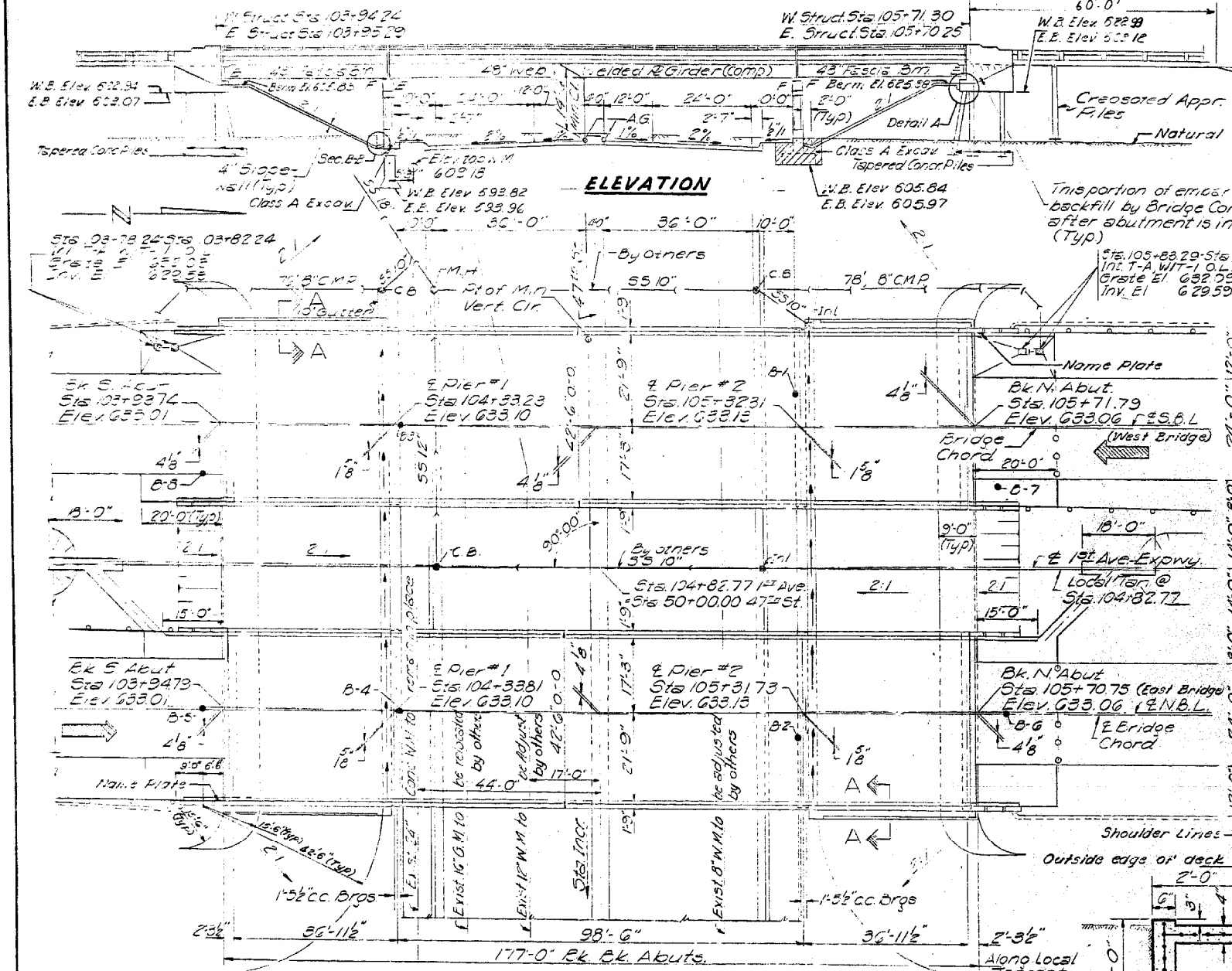

**GENERAL NOTES**

- Coarse aggregate to be used in parapet handrails and abutment wingwalls must be free of chert, flint, limestone, lignite, and sandstone.
- ~~The concrete floor shall be finished with a 6" thick concrete 1905 concrete W. base, 5" Ave 100' North of E 47th St. Elev. 632.29.~~
- ~~The concrete floor shall be finished with a 6" thick concrete 1905 concrete W. base, 5" Ave 100' North of E 47th St. Elev. 632.29.~~
- Slope Wall shall be reinforced with welded wire fabric 6"x6" mesh, weighing 58 Lb. per 100 Sq. Ft.
- All reinforcement bars shall be lapped 20 diameters unless otherwise shown.
- All structural steel shall conform to A.S.T.M. Designation A-36.
- Rivets 3/4" Ø, Open holes 1 1/2" Ø, unless otherwise noted.
- All welding shall conform to the current specifications for Welded Hwy. and Railway Bridges of the American Welding Society.
- Anchor bolts shall be set before bolting diaphragms over supports.
- Field welding of construction accessories to the bottom flanges will not be permitted. Field welding in other areas will be permitted only when approved by the Engineer.
- Stud shear connectors on the girder flanges shall be placed in the field after the steel has been erected and the deck forms are in place.
- Flange shear connectors are included in the quantity of structural steel. Number required = 4656. Estimated weight = 2860 lbs.
- Exposed surfaces of the expansion devices, inaccessible after erection, shall receive two shop coats of red lead paint. All other surfaces shall be given one shop coat of red lead paint. Anchor studs shall not be painted.
- Expansion devices are included in the quantity of structural steel. Estimated weight = 8840 lbs.
- Embankment drainage structures by others.
- Permanent forms will not be permitted in forming the concrete floor.
- The contractor shall drive one conc. test pile at the North West Abut. and one at the South East Abut., both in a permanent location as directed by the Engineer, before ordering the remainder of the piles.
- Excavation for portions of the structures in the embankments shall not be classified.
- Except as otherwise provided, all structural steel shall receive one shop coat of red lead paint and two field coats of paint. See special provisions for field paint.
- Concrete piles at abutments shall be driven in holes precast through the embankment in accordance with Article 60.9(c) of the Standard Specifications.
- See Special Provisions for placement of Bituminous Concrete Surface Course Subclass T-11 and Coal Tar Interlayer Protective Coat.

**TOTAL BILL OF MATERIAL**

| Item                                 | Unit     | Super  | Sub.  | Total  |
|--------------------------------------|----------|--------|-------|--------|
| Class A Exca. For Structures         | Cu. Yds. |        |       | 26.0   |
| Class A Concrete                     | Cu. Yds. | 446.9  | 4226  | 869.5  |
| Protective Coat                      | Sq. Yds. |        |       | 400    |
| Structural Steel                     | Lbs.     | 44160  |       | 44160  |
| Aluminum Handrail                    | Lin. Ft. | 695    |       | 695    |
| Reinforcement Bars                   | Lbs.     | 106940 | 42980 | 149920 |
| Concrete Piles                       | Lin. Ft. |        |       | 1100   |
| Test Piles (Concrete)                | Ea.      |        |       | 2      |
| Crested Appr. Piles                  | Lin. Ft. |        |       | 200    |
| Caisson Concrete                     | Cu. Yds. |        | 40    | 40     |
| Preformed Joint Sealant              | Lin. Ft. | 338    |       | 338    |
| Name Plates                          | Ea.      | 2      |       | 2      |
| Slope Wall (4")                      | Sq. Yds. |        |       | 108.0  |
| Coal Tar Interlayer Protective Coat  | Sq. Yds. |        |       | 1430   |
| Bit. Conc. Surf. Crse. Subclass T-11 | Tons     |        |       | 116.4  |

**STATION 104+82.77**  
BUILT 1966 BY  
STATE OF ILLINOIS  
E.A. RT 133 SEC. 0102-683HBK  
E.A. PROJ. U-383 (31)  
LOADING HS 20

**NAME PLATE**  
(See Std. 2113-1)

**MAX. FTG. PRESSURES**  
Pier 1 = 7 ksf  
Pier 2 = 5 ksf

**FILE DATA**

Type Crested  
Number Req'd 24  
Zero Length 25'-0"

**CURVE DATA**

(First Ave Expressway)  
P.I. Sta. 105+97.15  
Δ=14° L=1,400'  
D=1° E=43.028'  
T=703.504' R=5789.58'

**PROFILE 47th ST**

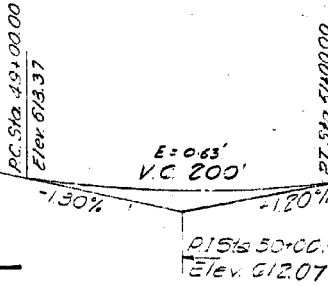

**PROFILE 1st AVE EXPRESSWAY**

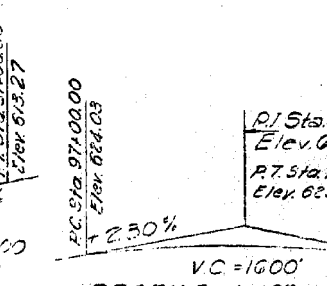

**SECTION A-A**

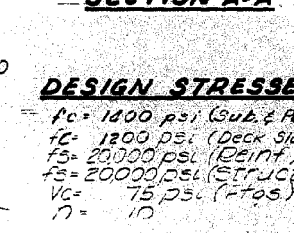

**DESIGN STRESSES**

- f<sub>c</sub> = 1400 psi (Sub. & Parapet)
- f<sub>c</sub> = 1200 psi (Deck Slab)
- f<sub>s</sub> = 20000 psi (Reinf.)
- f<sub>s</sub> = 20000 psi (Struct.)
- V<sub>c</sub> = 75 psi (Ftgs.)
- n = 10

**Proposed Structure RISE**

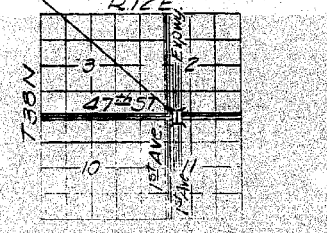

**LOCATION PLAN**



Note: See sheet 2 for Detail A and Sec. B-B

**PROJ. U-383 (31)**  
**GENERAL PLAN ELEVATION**  
**1st AVE EXPRESSWAY OVER 47th ST**  
**E.A. RT 133 SEC. 0102-683 HBK**  
**COOK COUNTY**  
**STATION 104+82.77**

**benesch**  
engineers · scientists · planners  
Alfred Benesch & Company  
205 North Michigan Avenue, Suite 2400  
Chicago, Illinois 60601  
312-565-0450 Job No. 10093

| FILE NAME                       | USER NAME | DESIGNED | CHECKED | DRAWN | CHECKED | REVISIONS |
|---------------------------------|-----------|----------|---------|-------|---------|-----------|
| 0161000.60J16.041.existplan.dgn | tjenicke  | FSM      | RMM     | FSM   | RMM     |           |
|                                 |           |          |         |       |         |           |
|                                 |           |          |         |       |         |           |
|                                 |           |          |         |       |         |           |

STATE OF ILLINOIS  
DEPARTMENT OF TRANSPORTATION

EXISTING PLAN INFORMATION (1 OF 25)  
STRUCTURE NO. 016-1000/101  
SHEET NO. SAX01 OF SAX25 SHEETS

FOR INFORMATION ONLY

| F.A.P. RTE.               | SECTION     | COUNTY | TOTAL SHEETS | SHEET NO. |
|---------------------------|-------------|--------|--------------|-----------|
| 372                       | 2013-038B-R | COOK   | 821          | 289       |
| CONTRACT NO. 60J16        |             |        |              |           |
| ILLINOIS FED. AID PROJECT |             |        |              |           |



|      |      |     |      |
|------|------|-----|------|
| DATE | BY   | NO. | REV. |
| 1953 | COOK | 149 | 105  |

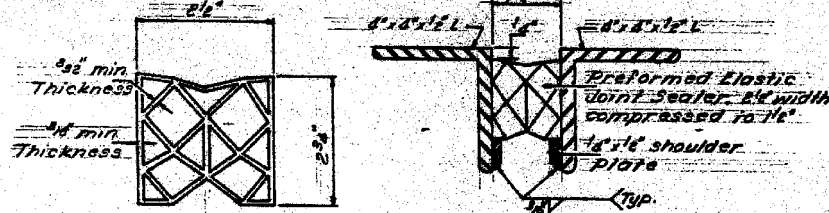
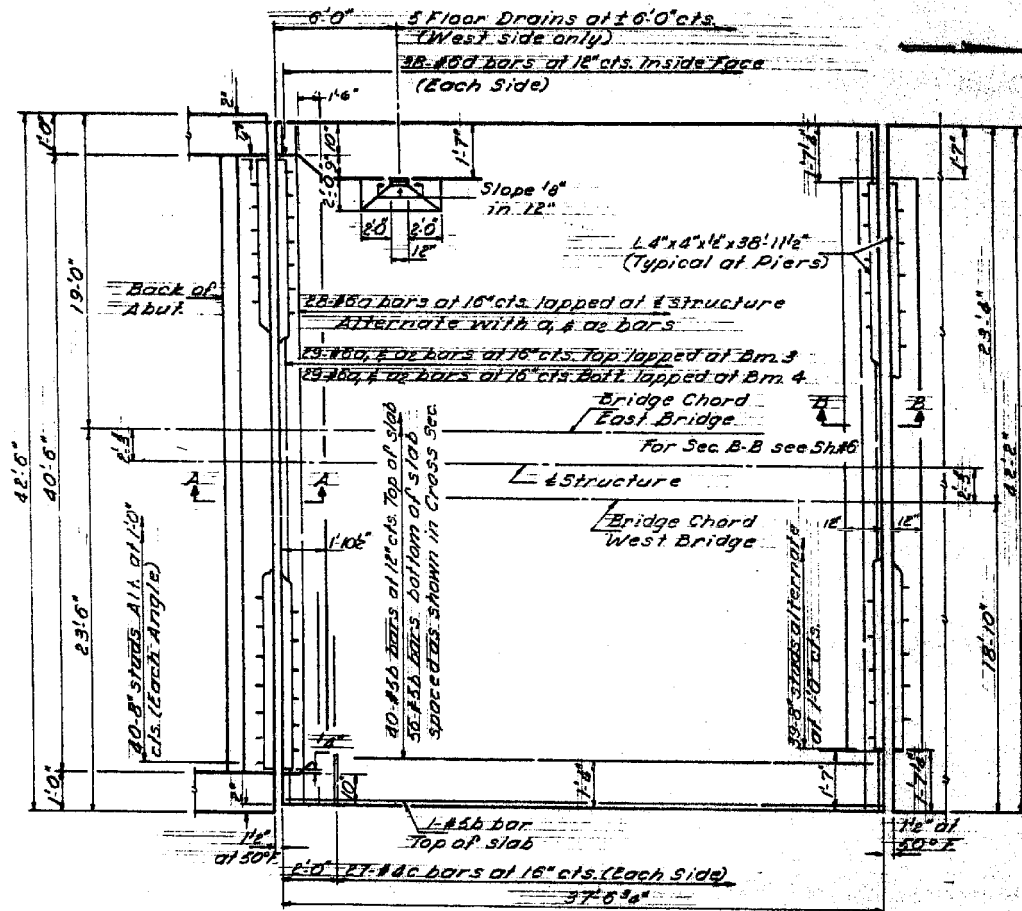

Note:  
Vent holes, bolt holes & anchor studs not shown.

**DETAIL OF PREFORMED ELASTIC JOINT SEALER**

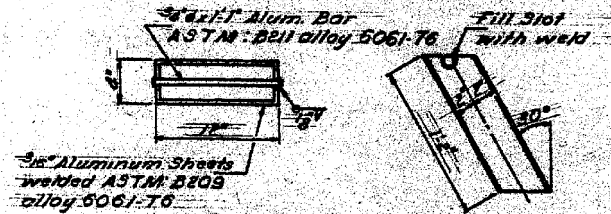

**FLOOR DRAIN DETAIL**

Cost of Aluminum Drains & Sheets shall be incidental to Class 1 Concrete

Note B:  
In places of 12" cts. for #8 bars set on 1/4" gage line, all bars shall be turned inside or clipped off flush with back of angle after joints are embedded.

Note C:  
1/2" vent holes at 16" cts. set on 1/4" gage line.

Note A:  
1/4" x 1/8" CR 1080 STL granular or solid flux filled heated studs, approximately end welded. (Other note at 1/5' cts.)

1/4" x 1/8" x 10' long Fabricate to cross

Note:  
Hatched area to be poured in place, superstructure & piers. Form work removed. Finishing of concrete included with superstructure.

**SECTION A-A**

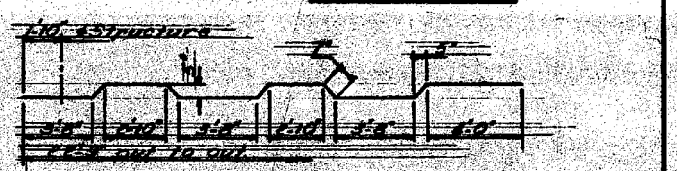

**BAR B**

**FOUR SPANS ALL OF MATERIAL**

| Span | NO. | 572 | 18mm Shore |
|------|-----|-----|------------|
| a    | 224 | 40  | 23.7       |
| b    | 232 | 45  | 25.9       |
| c    | 232 | 40  | 18.6       |
| d    | 392 | 45  | 57.0       |
| e    | 216 | 44  | 3.71       |
| f    | 308 | 40  | 3.9        |

Reinforcement Bars 125 41360  
Structural Steel 125 14290  
Class 1 Concrete Cu 103 77.1  
Preformed Elastic Joint Sealer 117.7 189

\* Weight of bearing assemblies with load plates & anchor bolts are included as structural steel. 251 Wt. = 10000 lbs.

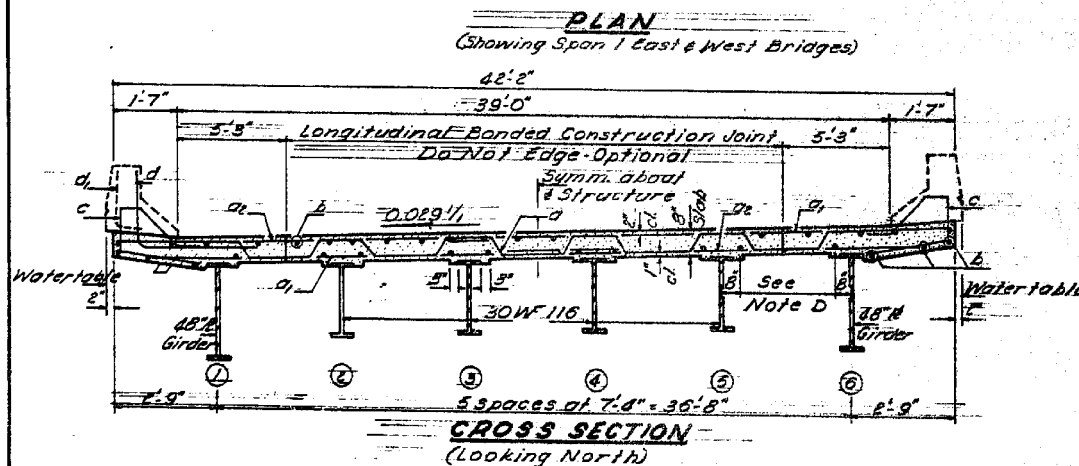

**CROSS SECTION (Looking North)**

Note D:  
10-#5b bars at 8' cts. Typical Spacing

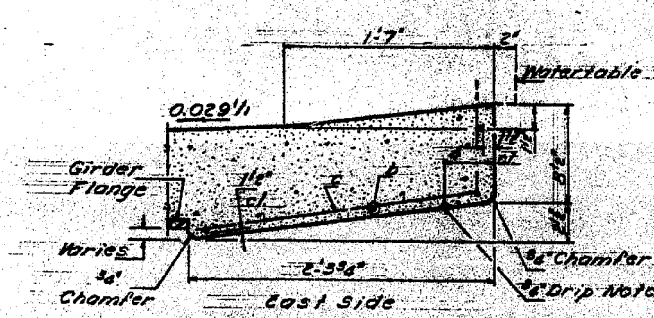
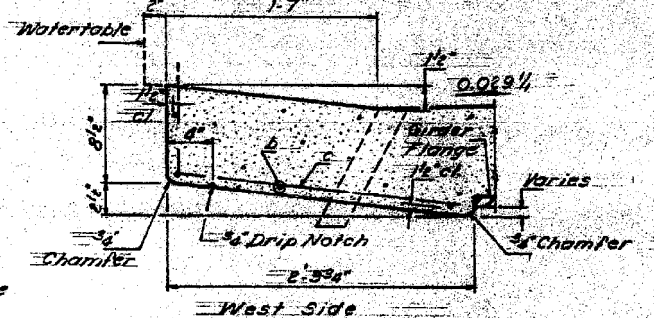

**SLAB EDGE DETAILS**

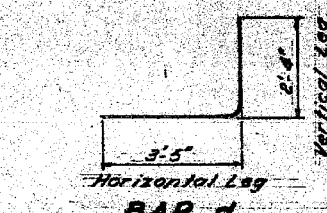

**BAR D**

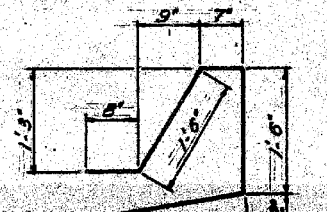

**BAR C**

DESIGNED *John Hayes*  
CHECKED *Stacy L.*  
DRAWN *J. Kessler*  
CHECKED *Stacy L.*

EXAMINED *W. J. Thumm*  
PASSED *W. J. Thumm*  
APPROVED *W. J. Thumm*

SEPT 28 1967

**SUPERSTRUCTURE EAST & WEST BRIDGES**  
SPAN 1  
F.A. RT 139 S.W. GIOE-683 H&K  
COOK COUNTY  
STATION 104+88.77

|                                 |                      |                |           |
|---------------------------------|----------------------|----------------|-----------|
| FILE NAME =                     | USER NAME = tjenicke | DESIGNED - FSM | REVISED - |
| 0161000.60J16.042.existplan.dgn |                      | CHECKED - RMM  | REVISED - |
|                                 |                      | DRAWN - FSM    | REVISED - |
|                                 |                      | CHECKED - RMM  | REVISED - |
|                                 |                      |                |           |

FOR INFORMATION ONLY

| F.A.P. RTE. | SECTION     | COUNTY | TOTAL SHEETS | SHEET NO. |
|-------------|-------------|--------|--------------|-----------|
| 372         | 2013-038B-R | COOK   | 821          | 290       |

CONTRACT NO. 60J16  
ILLINOIS FED. AID PROJECT

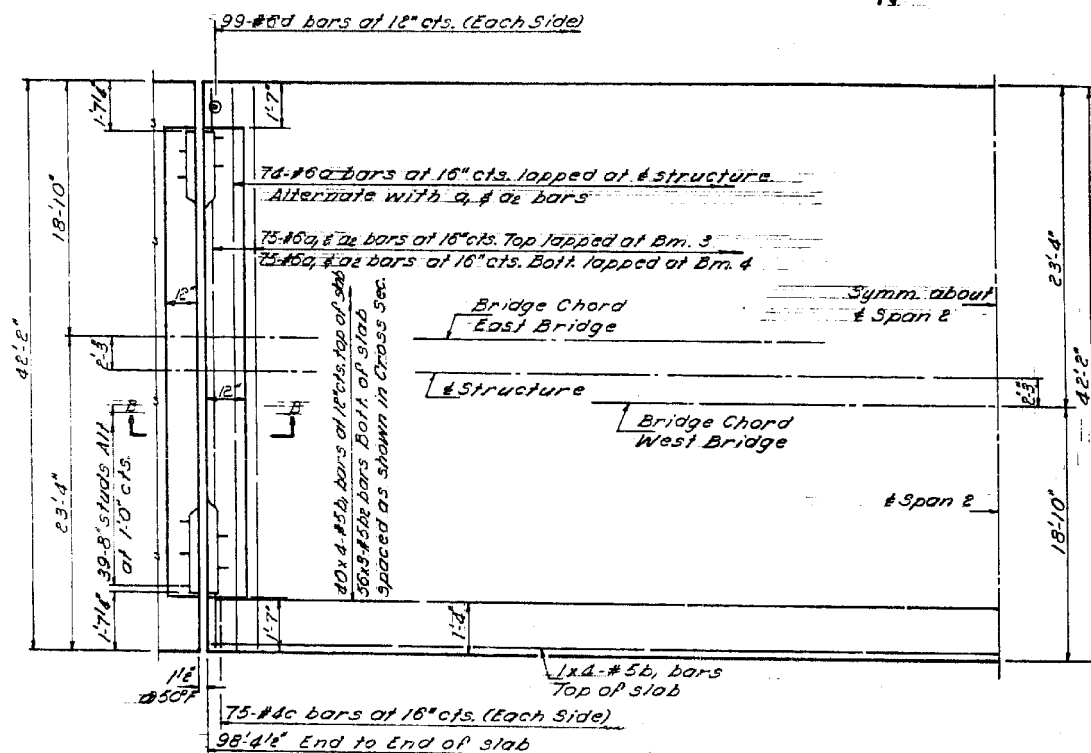

**HALF PLAN**  
(Span 2 East & West Bridges)

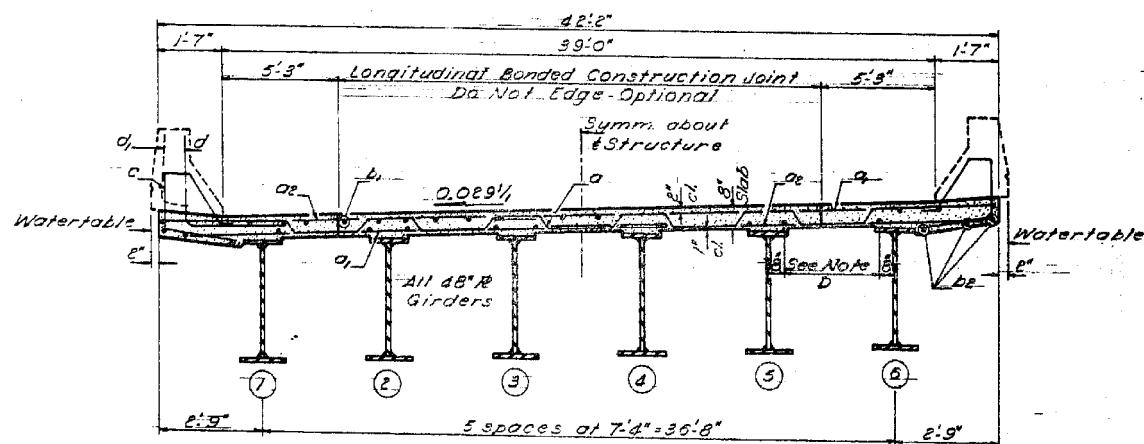

**CROSS SECTION**  
(Looking North)

Note D:  
10-#5b bars at 8" cts.  
Typical spacing

DESIGNED: John Harper  
CHECKED: J. Kessler  
DRAWN: J. Kessler  
CHECKED: J. Kessler

EXAMINED: [Signature]  
PASSED: [Signature]  
APPROVED: [Signature]

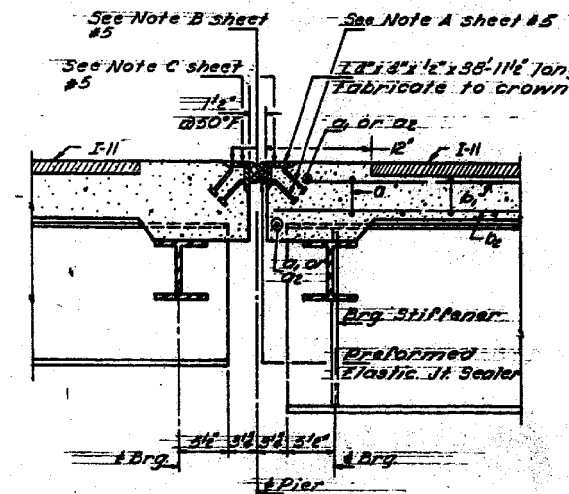

**SECTION B-B**

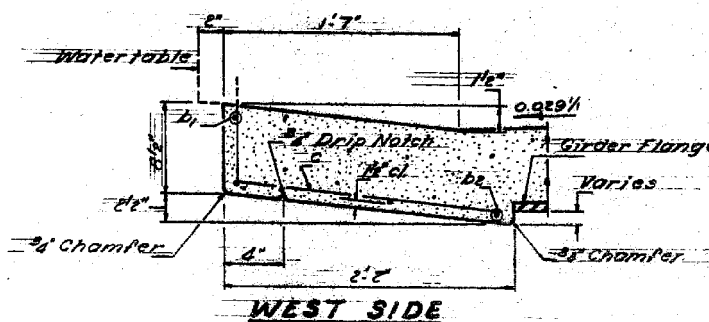

**WEST SIDE**

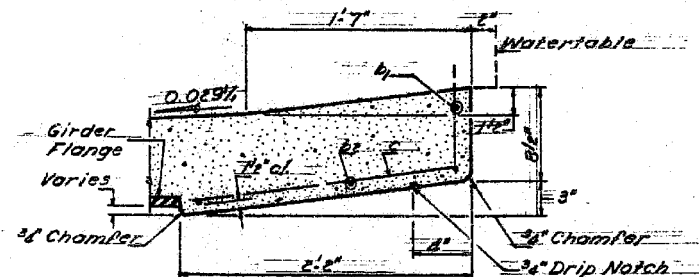

**EAST SIDE**  
**SLAB EDGE DETAILS**

**2 SPANS**  
**BILL OF MATERIAL**

| Bar   | No. | Size | Length | Shape |
|---|-----|------|--------|-------|
| a   | 296 | #6   | 23'-7" | ~     |
| b   | 300 | #6   | 23'-9" | ~     |
| c   | 300 | #6   | 18'-0" | ~     |
| d   | 536 | #5   | 22'-6" | ~     |
| e   | 536 | #5   | 33'-6" | ~     |
| f   | 300 | #4   | 3'-11" | ~     |
| g   | 390 | #6   | 3'-9"  | ~     |
| <b>Reinforcement Bars</b> - lbs. 55710              |     |      |        |       |
| <b>Structural Steel</b> - lbs. 499240               |     |      |        |       |
| <b>Class X Concrete</b> - cu yds. 209.6             |     |      |        |       |
| <b>Preformed Elastic Joint Sealer</b> - lbs. 11.169 |     |      |        |       |

\* Weight of bearing assemblies with lead plates and anchor bolts are included as structural steel.  
Estimated W.K. = 3000 lbs.

**SUPERSTRUCTURE**  
**EAST & WEST RIDGES**  
**SPAN 2**  
**E.A. RT. 133 SEC. 0102-683 HB K**  
**COOK COUNTY**  
**STATION 104+82.11**

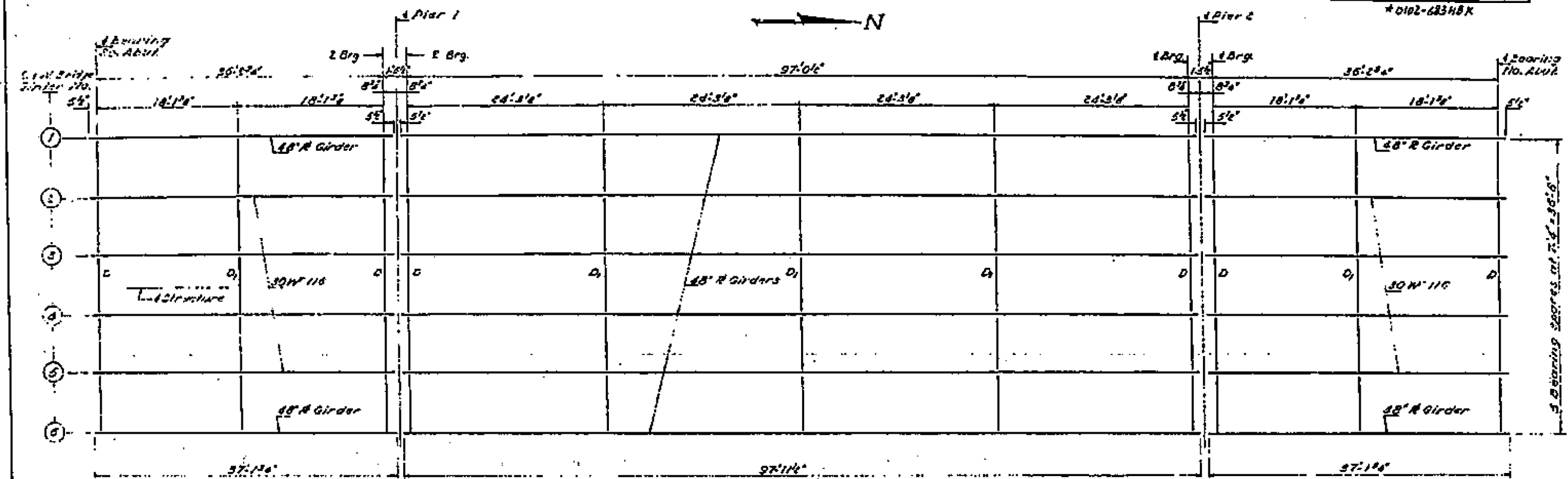

**FRAMING PLAN**

**SPANS 1 OR 3**

TABLE OF MOMENTS & SHEARS  
INTERIOR BEAMS

| D.L.   | Max. Moment @ Sp. | Max. Shear @ Abut. & Piers |
|--------|-------------------|----------------------------|
| D.L.   | 198.3             | 21.8                       |
| L.L.   | 255.3             | 25.6                       |
| Impact | 76.6              | 10.8                       |
| Total  | 330.2             | 58.2                       |

- D.L. Dead Load
- L.L. Superimposed Dead Load on Composite Section
- Impact
- Moment of Inertia Steel Section
- Section Modulus Parallel Section
- Section Modulus Bottom Steel Section
- Moment of Inertia Composite Section
- Section Modulus Top Composite Section
- Section Modulus Bottom Composite Section

Moments are in Ft. Kips  
Reactions and Shears are in Kips

**SPAN 2**

TABLE OF MOMENTS & SHEARS  
INTERIOR GIRDERS

| D.L.   | STEEL SECTION<br>MAXIMUM MOMENT |
|--------|---------------------------------|
| D.L.   | 1210.1                          |
| S.D.L. | 376.7                           |
| L.L.   | 979.6                           |
| Impact | 220.4                           |
| Total  | 2786.8                          |

| D.L.   | SHEAR   |       |       |
|--------|---------|-------|-------|
|        | Support | Spout | Spout |
| S.D.L. | 15.5    | 6.2   | 0     |
| L.L.   | 23.4    | 22.0  | 19.4  |
| Impact | 9.8     | 6.5   | 4.3   |
| Total  | 48.7    | 34.7  | 23.7  |

**SPAN 2 PROPERTIES\***

| STEEL SECTION     |                          |
|-------------------|--------------------------|
| I <sub>x</sub>    | 33377.0 in. <sup>4</sup> |
| S <sub>x</sub>    | 1106.7 in. <sup>3</sup>  |
| I <sub>y</sub>    | 1590.9 in. <sup>4</sup>  |
| COMPOSITE SECTION |                          |
| I <sub>c</sub>    | 73992.6 in. <sup>4</sup> |
| S <sub>xc</sub>   | 4460.0 in. <sup>3</sup>  |
| S <sub>yc</sub>   | 1269.2 in. <sup>3</sup>  |

\*Midspan

DESIGNED: [Signature]  
CHECKED: [Signature]  
DRAWN: J.A. [Signature]  
CHECKED: [Signature]

SEPT 28 1967  
APPROVED: [Signature]

**STRUCTURAL STEEL  
FRAMING PLAN  
EAST & WEST BRIDGES  
E.A. RT. 133 SEC. 0102-683 HBK  
COOK COUNTY  
STATION 194+82.77**

|   |                      |                |           |
|---|----------------------|----------------|-----------|
| FILE NAME = 0161000_60J16_044_existplan.dgn | USER NAME = tjenicke | DESIGNED - FSM | REVISIONS |
|   |                      | CHECKED - RMM  | REVISIONS |
|   |                      | DRAWN - FSM    | REVISIONS |
|   |                      | CHECKED - RMM  | REVISIONS |
|   |                      |                | REVISIONS |

| F.A.P. RTE.               | SECTION     | COUNTY | TOTAL SHEETS | SHEET NO. |
|---------------------------|-------------|--------|--------------|-----------|
| 372                       | 2013-038B-R | COOK   | 821          | 292       |
| CONTRACT NO. 60J16        |             |        |              |           |
| ILLINOIS FED. AID PROJECT |             |        |              |           |



# 0102-68348R

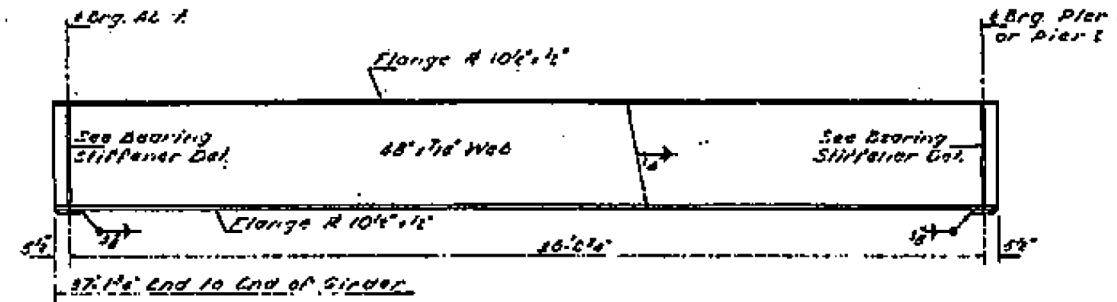

FACIA GIRDER ELEVATION

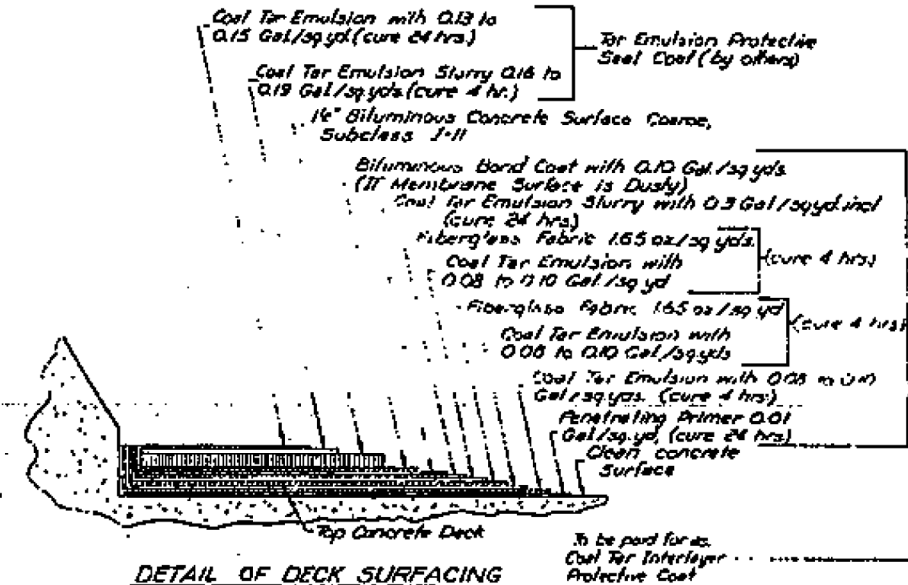

DETAIL OF DECK SURFACING

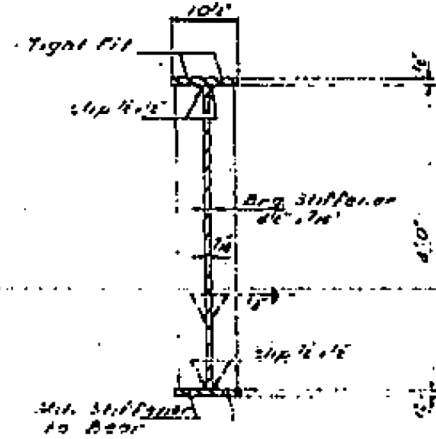

BEARING STIFFENER DETAIL

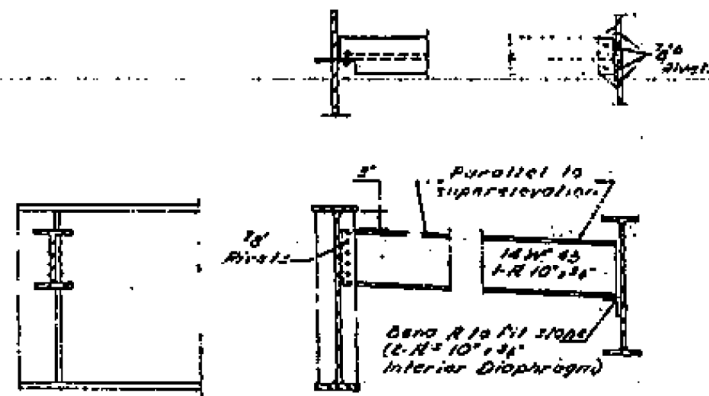

DIAPHRAGM D  
(NO Required)

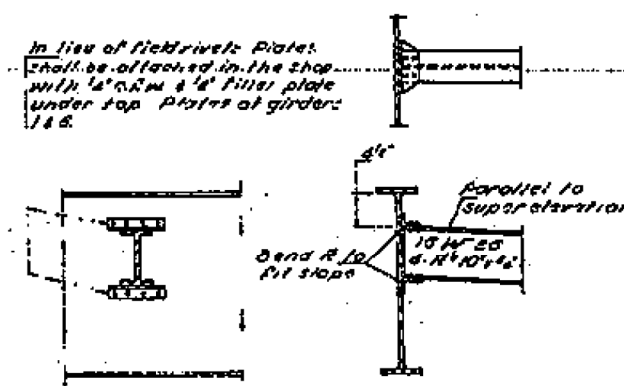

DIAPHRAGM D1  
(NO Required)

Notes:  
See sheet 10 for Bearing Details and sheet 17 for Framing Plan.  
For details of welding designations see AWS D2.0 Specifications.  
Weight of structural steel billed on sheet 5.

DESIGNED: [Signature]  
CHECKED: [Signature]  
DRAWN: J. P. [Signature]  
CHECKED: [Signature]  
SEPT. 28 1960  
EXAMINED: [Signature]  
PASSED: [Signature]  
APPROVED: [Signature]

STRUCTURAL STEEL DETAILS  
SPANS 143  
EAST & WEST BRIDGES  
FA. RT. 153 SEC. 0102-683 HBX  
COOK COUNTY  
STATION 104+88.77

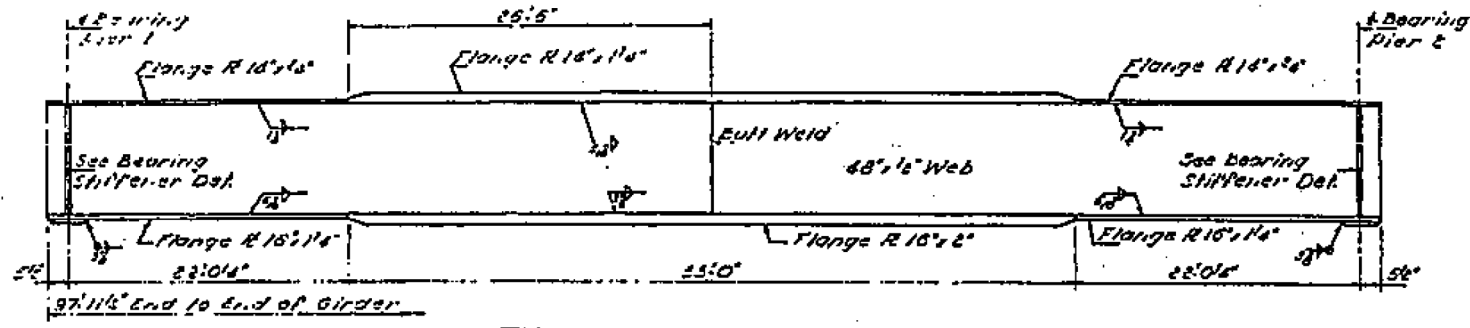

TYPICAL GIRDER ELEVATION

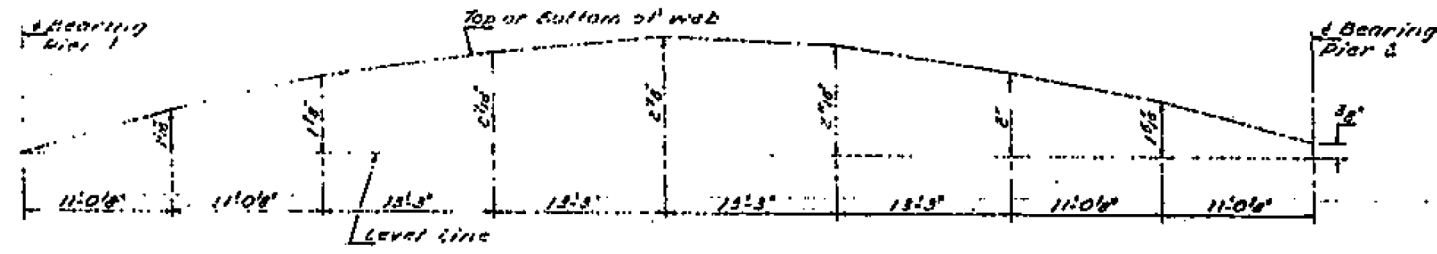

CAMBER DIAGRAM

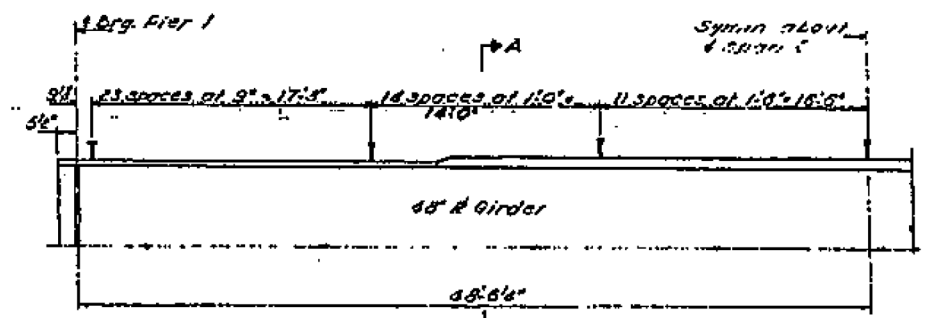

PARTIAL ELEVATION  
(Showing shear connector spacing all girders)

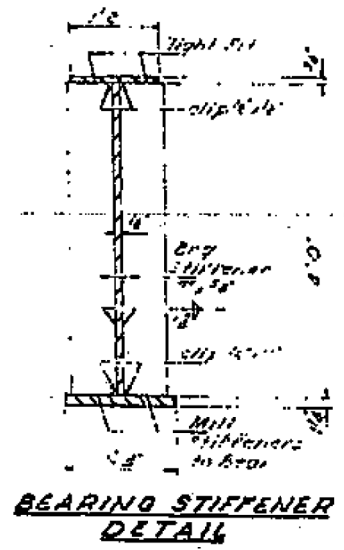

BEARING STIFFENER DETAIL

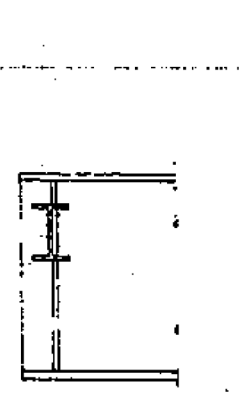

DIAPHRAGM D1  
10 Required

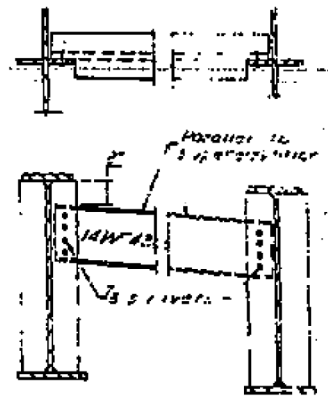

DIAPHRAGM D2  
30 Required

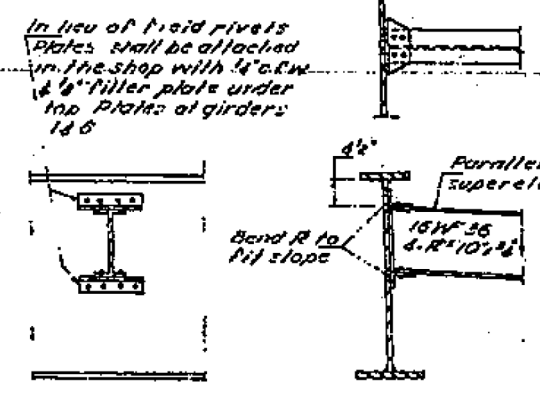

SHOP FLANGE SPLICE

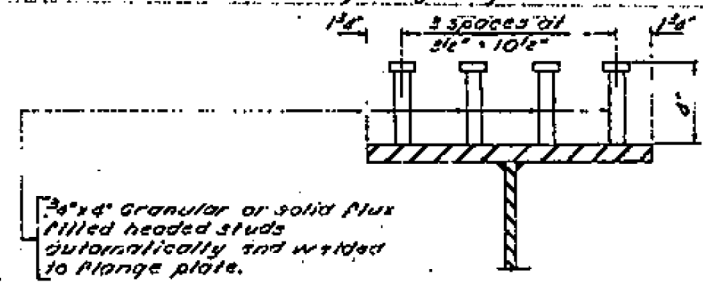

SECTION A-A

Notes  
See sheet 10 for bearing details & sheet 7 for framing plan.  
All butt welded joints shall be prequalified according to AWS D1.0-66 Specifications.  
For details of welding designations see AWS D2.0-66 specifications.  
Weight of structural steel listed on sheet 6.

|          |           |          |              |
|----------|-----------|----------|--------------|
| DESIGNED | J. K. ... | EXAMINED | SECT 38 1967 |
| CHECKED  |           | DRAWN    | J. K. ...    |
| DRAWN    | J. K. ... | APPROVED |              |
| CHECKED  |           |          |              |

STRUCTURAL STEEL DETAILS  
SPAN 2  
EAST & WEST BRIDGES  
RA. RT. 133 - SEC. 0102-683 H&K  
COOK COUNTY  
STATION 104 + 82.77

|                                 |                        |                |           |
|---------------------------------|------------------------|----------------|-----------|
| FILE NAME =                     | USER NAME = tjenicke   | DESIGNED - FSM | REVISIONS |
| 0161000_60J16_046_existplan.dgn | PLOT SCALE =           | CHECKED - RMM  | REVISIONS |
|                                 | PLOT DATE = 12/20/2012 | DRAWN - FSM    | REVISIONS |
|                                 |                        | CHECKED - RMM  | REVISIONS |

|                           |             |        |                    |           |
|---------------------------|-------------|--------|--------------------|-----------|
| FOR INFORMATION ONLY      |             |        |                    |           |
| F.A.P. RTE.               | SECTION     | COUNTY | TOTAL SHEETS       | SHEET NO. |
| 372                       | 2013-038B-R | COOK   | 821                | 294       |
|                           |             |        | CONTRACT NO. 60J16 |           |
| ILLINOIS FED. AID PROJECT |             |        |                    |           |

X:\1000005\10093\Eng\_Docs\_Phase\_1\1000000\_1001\_1st\_Ave\_over\_47th\_St\Final\0161000\_60J16\_046\_existplan.dgn 2:29:16 PM 6/23/2014

STATE OF ILLINOIS  
DEPARTMENT OF PUBLIC WORKS & BUILDINGS  
DIVISION OF HIGHWAYS

|            |         |         |           |              |
|------------|---------|---------|-----------|--------------|
| DESIGN NO. | PROJECT | SECTION | SHEET NO. | TOTAL SHEETS |
| 133        | COOK    | 149     | 110       | 23           |

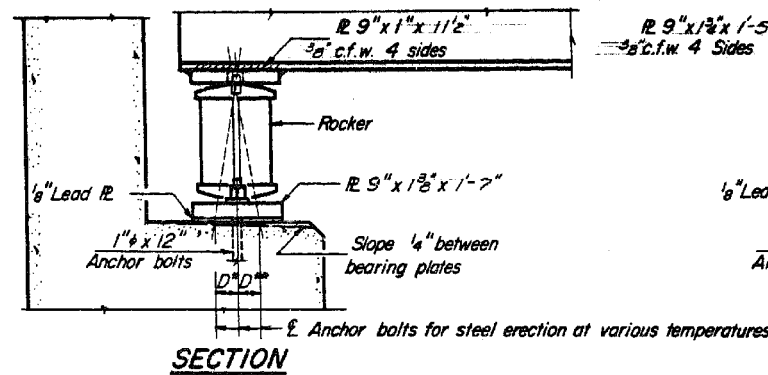

SECTION

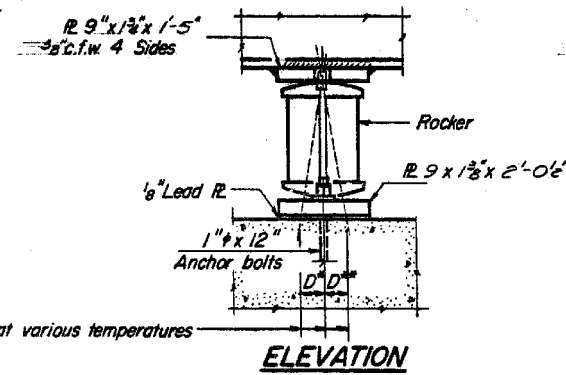

ELEVATION

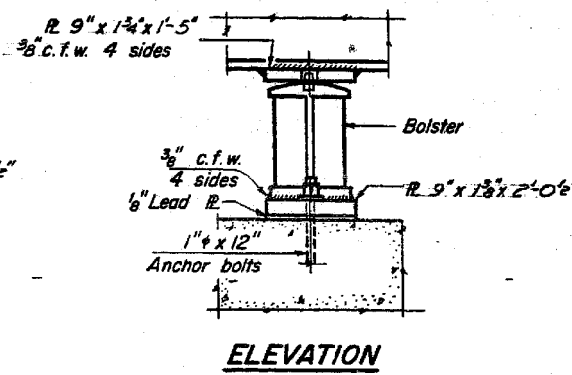

ELEVATION

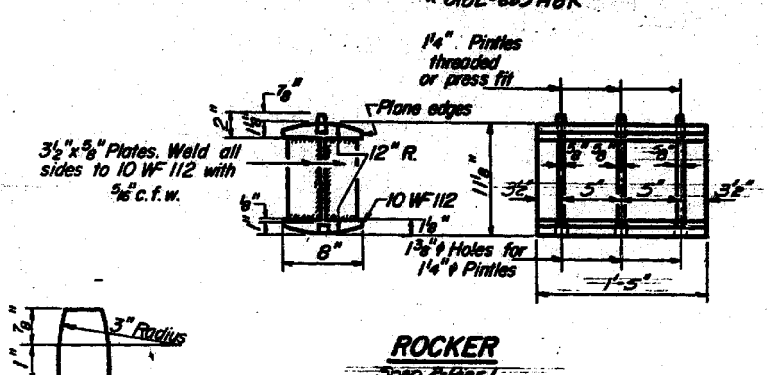

ROCKER

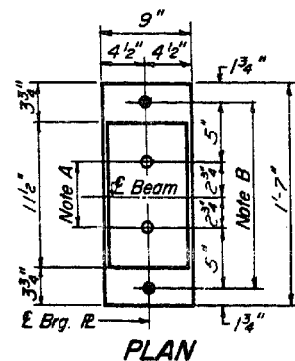

PLAN  
AT ABUTMENTS

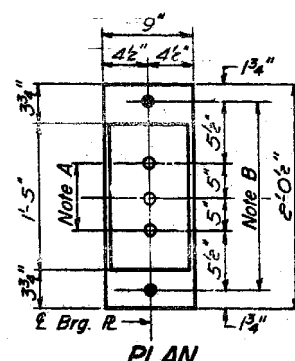

PLAN  
AT PIER 1

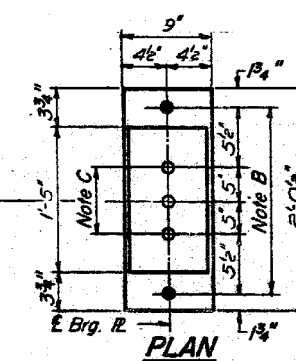

PLAN  
AT PIER 2

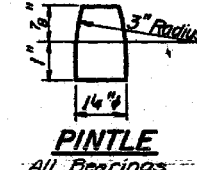

PINTE

All Bearings

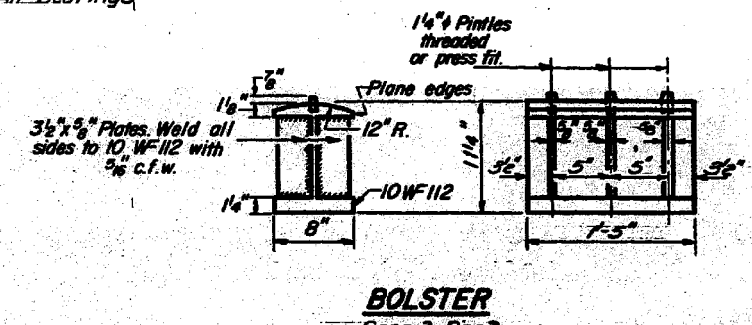

BOLSTER

NOTE A  
1 1/2" Holes - 1" deep in top R.  
for pintles. Thread or press fit  
pintles into bottom R.

NOTE B  
1 1/2" Holes for 1" anchor bolts.  
2 1/2 x 2 1/2 x 5/16" R. Washers  
under nut.

NOTE C  
1 3/8" Holes 1" deep in top R.  
only for 1 1/2" pintles.

NOTES ON SETTING OF ANCHOR BOLTS AT EXP. BRGS.

- a) D\* (Side of brg. away from fixed brg.)  
D\* = 1/8" per each 100' of expansion for every 15° fall below the normal temp. of 50°F.
- D\*\* (Side of brg. toward fixed brg.)  
D\*\* = 1/8" per each 100' of expansion for every 15° rise above the normal temp. of 50°F.
- b) After beams have been erected and dimensions D\* or D\*\* determined, holes shall be drilled and anchor bolts shall be grouted in place. All fixed anchor bolts may be built into the masonry.

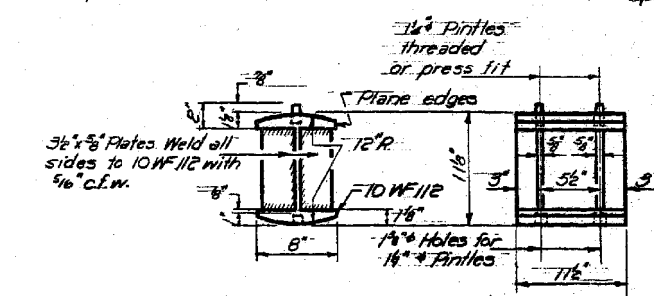

ROCKER

At Abutments

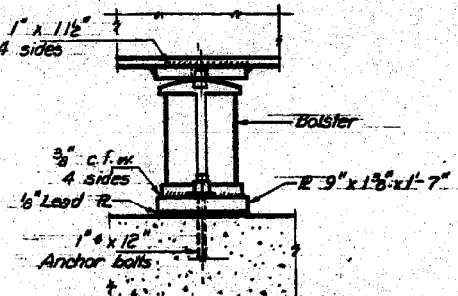

ELEVATION

Spans 113 of Piers 112

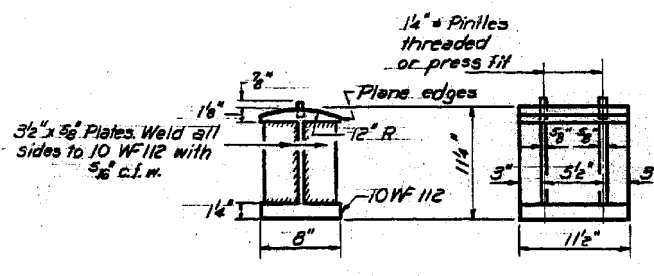

BOLSTER

Spans 113 of Piers 112

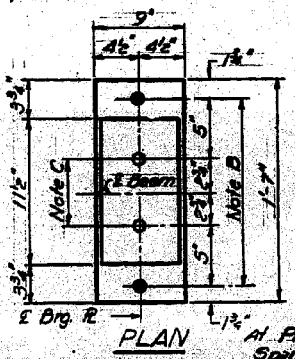

PLAN

At Piers 112  
Span 113

|          |               |          |              |
|----------|---------------|----------|--------------|
| DESIGNED | John Hoyer    | EXAMINED | Sept 28 1967 |
| CHECKED  | Stanley S. L. | PASSED   | W.E. Baumann |
| DRAWN    | J.M. HENINGER | APPROVED |              |
| CHECKED  | Stanley S. L. |          |              |

I-2-B 9-1-65

BEARING DETAILS  
EAST & WEST BRIDGES  
F.A. RT. 133 SEC. 0102-683 HBK  
COOK COUNTY  
STA. 104+82.77

|                                 |             |            |           |
|---------------------------------|-------------|------------|-----------|
| FILE NAME =                     | USER NAME = | DESIGNED - | REVISIONS |
| 0161000.60J16.047.existplan.dgn | tjenicke    | FSM        |           |
|                                 |             | RMM        |           |
|                                 |             | FSM        |           |
|                                 |             | RMM        |           |

|                           |             |        |                    |           |
|---------------------------|-------------|--------|--------------------|-----------|
| FOR INFORMATION ONLY      |             |        |                    |           |
| F.A.P. RTE.               | SECTION     | COUNTY | TOTAL SHEETS       | SHEET NO. |
| 372                       | 2013-038B-R | COOK   | 821                | 295       |
|                           |             |        | CONTRACT NO. 60J16 |           |
| ILLINOIS FED. AID PROJECT |             |        |                    |           |

X:\1000005\10093\Eng\_Docs\_Phase\_II\SN\_016\_1000\_1001\_1st\_Ave\_over\_47th\_St\Final\01610000\_60J16\_047\_existplan.dgn 6/23/2014 2:29:29 PM

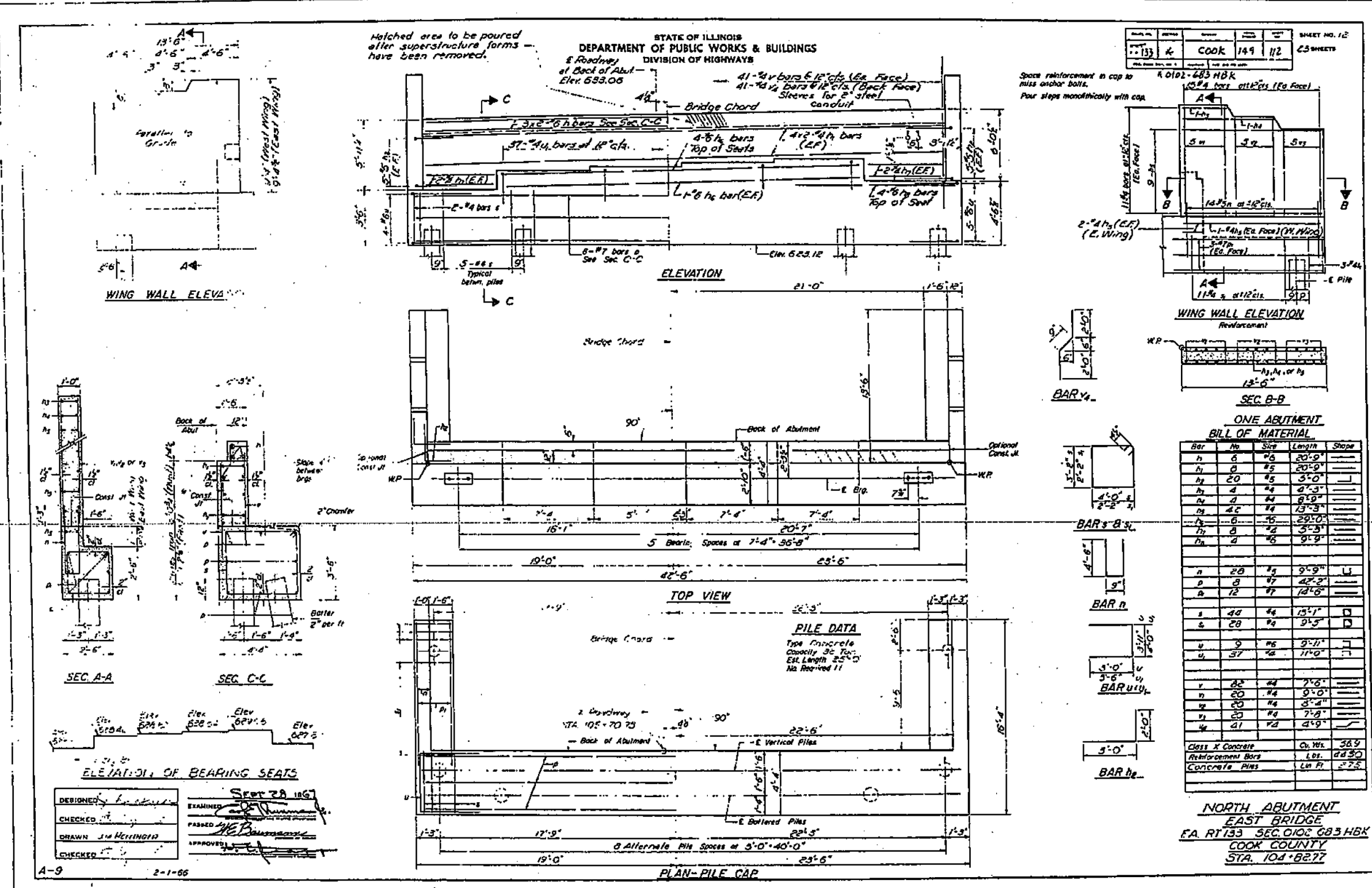

|             |     |          |              |            |    |
|-------------|-----|----------|--------------|------------|----|
| Project No. | 133 | Contract | COOK 149 112 | Sheet No.  | 12 |
| Scale       |     | Drawn by |              | Checked by |    |

**ONE ABUTMENT  
BILL OF MATERIAL**

| Bar No.            | Size | Length | Shape |
|--------------------|------|--------|-------|
| h                  | #6   | 20'-9" | U     |
| h <sub>1</sub>     | #5   | 20'-9" | U     |
| h <sub>2</sub>     | #5   | 3'-0"  | U     |
| h <sub>3</sub>     | #4   | 0'-3"  | U     |
| h <sub>4</sub>     | #4   | 0'-9"  | U     |
| h <sub>5</sub>     | #4   | 13'-3" | U     |
| h <sub>6</sub>     | #5   | 29'-0" | U     |
| h <sub>7</sub>     | #4   | 3'-3"  | U     |
| h <sub>8</sub>     | #6   | 9'-9"  | U     |
| i                  | #4   | 9'-9"  | U     |
| p                  | #7   | 42'-2" | U     |
| r                  | #7   | 14'-0" | U     |
| s                  | #4   | 15'-1" | D     |
| t                  | #4   | 9'-5"  | D     |
| v                  | #6   | 9'-11" | U     |
| w                  | #4   | 11'-0" | U     |
| y                  | #4   | 7'-0"  | U     |
| z                  | #4   | 9'-0"  | U     |
| aa                 | #4   | 3'-4"  | U     |
| ab                 | #4   | 7'-8"  | U     |
| ac                 | #4   | 4'-0"  | U     |
| Class X Concrete   |      | Cu Wt. | 58.9  |
| Reinforcement Bars |      | Lbs.   | 4130  |
| Concrete Piles     |      | Lbs P. | 275   |

**NORTH ABUTMENT  
EAST BRIDGE  
FA. RT 133 SEC. 0108 683 HBK  
COOK COUNTY  
STA. 104+82.77**

DESIGNED: *[Signature]*  
CHECKED: *[Signature]*  
DRAWN: J.M. McINTOSH  
CHECKED: *[Signature]*

EXAMINED: *[Signature]*  
PASSED: *[Signature]*  
APPROVED: *[Signature]*

Spec 28 1867

2-1-65

|   |                      |                |                |
|---|----------------------|----------------|----------------|
| FILE NAME = 0161000.60J16.048.existplan.dgn | USER NAME = tjenicke | DESIGNED - FSM | REVISIONS      |
|   |                      | CHECKED - RMM  | 1. REVISED -   |
|   |                      | DRAWN - FSM    | 2. REVISED -   |
|   |                      | CHECKED - RMM  | 3. REVISED -   |
|   |                      |                | 4. REVISED -   |
|   |                      |                | 5. REVISED -   |
|   |                      |                | 6. REVISED -   |
|   |                      |                | 7. REVISED -   |
|   |                      |                | 8. REVISED -   |
|   |                      |                | 9. REVISED -   |
|   |                      |                | 10. REVISED -  |
|   |                      |                | 11. REVISED -  |
|   |                      |                | 12. REVISED -  |
|   |                      |                | 13. REVISED -  |
|   |                      |                | 14. REVISED -  |
|   |                      |                | 15. REVISED -  |
|   |                      |                | 16. REVISED -  |
|   |                      |                | 17. REVISED -  |
|   |                      |                | 18. REVISED -  |
|   |                      |                | 19. REVISED -  |
|   |                      |                | 20. REVISED -  |
|   |                      |                | 21. REVISED -  |
|   |                      |                | 22. REVISED -  |
|   |                      |                | 23. REVISED -  |
|   |                      |                | 24. REVISED -  |
|   |                      |                | 25. REVISED -  |
|   |                      |                | 26. REVISED -  |
|   |                      |                | 27. REVISED -  |
|   |                      |                | 28. REVISED -  |
|   |                      |                | 29. REVISED -  |
|   |                      |                | 30. REVISED -  |
|   |                      |                | 31. REVISED -  |
|   |                      |                | 32. REVISED -  |
|   |                      |                | 33. REVISED -  |
|   |                      |                | 34. REVISED -  |
|   |                      |                | 35. REVISED -  |
|   |                      |                | 36. REVISED -  |
|   |                      |                | 37. REVISED -  |
|   |                      |                | 38. REVISED -  |
|   |                      |                | 39. REVISED -  |
|   |                      |                | 40. REVISED -  |
|   |                      |                | 41. REVISED -  |
|   |                      |                | 42. REVISED -  |
|   |                      |                | 43. REVISED -  |
|   |                      |                | 44. REVISED -  |
|   |                      |                | 45. REVISED -  |
|   |                      |                | 46. REVISED -  |
|   |                      |                | 47. REVISED -  |
|   |                      |                | 48. REVISED -  |
|   |                      |                | 49. REVISED -  |
|   |                      |                | 50. REVISED -  |
|   |                      |                | 51. REVISED -  |
|   |                      |                | 52. REVISED -  |
|   |                      |                | 53. REVISED -  |
|   |                      |                | 54. REVISED -  |
|   |                      |                | 55. REVISED -  |
|   |                      |                | 56. REVISED -  |
|   |                      |                | 57. REVISED -  |
|   |                      |                | 58. REVISED -  |
|   |                      |                | 59. REVISED -  |
|   |                      |                | 60. REVISED -  |
|   |                      |                | 61. REVISED -  |
|   |                      |                | 62. REVISED -  |
|   |                      |                | 63. REVISED -  |
|   |                      |                | 64. REVISED -  |
|   |                      |                | 65. REVISED -  |
|   |                      |                | 66. REVISED -  |
|   |                      |                | 67. REVISED -  |
|   |                      |                | 68. REVISED -  |
|   |                      |                | 69. REVISED -  |
|   |                      |                | 70. REVISED -  |
|   |                      |                | 71. REVISED -  |
|   |                      |                | 72. REVISED -  |
|   |                      |                | 73. REVISED -  |
|   |                      |                | 74. REVISED -  |
|   |                      |                | 75. REVISED -  |
|   |                      |                | 76. REVISED -  |
|   |                      |                | 77. REVISED -  |
|   |                      |                | 78. REVISED -  |
|   |                      |                | 79. REVISED -  |
|   |                      |                | 80. REVISED -  |
|   |                      |                | 81. REVISED -  |
|   |                      |                | 82. REVISED -  |
|   |                      |                | 83. REVISED -  |
|   |                      |                | 84. REVISED -  |
|   |                      |                | 85. REVISED -  |
|   |                      |                | 86. REVISED -  |
|   |                      |                | 87. REVISED -  |
|   |                      |                | 88. REVISED -  |
|   |                      |                | 89. REVISED -  |
|   |                      |                | 90. REVISED -  |
|   |                      |                | 91. REVISED -  |
|   |                      |                | 92. REVISED -  |
|   |                      |                | 93. REVISED -  |
|   |                      |                | 94. REVISED -  |
|   |                      |                | 95. REVISED -  |
|   |                      |                | 96. REVISED -  |
|   |                      |                | 97. REVISED -  |
|   |                      |                | 98. REVISED -  |
|   |                      |                | 99. REVISED -  |
|   |                      |                | 100. REVISED - |

| F.A.P. RTE.               | SECTION     | COUNTY | TOTAL SHEETS | SHEET NO.          |
|---------------------------|-------------|--------|--------------|--------------------|
| 372                       | 2013-038B-R | COOK   | 821          | 296                |
|                           |             |        |              | CONTRACT NO. 60J16 |
| ILLINOIS FED. AID PROJECT |             |        |              |                    |

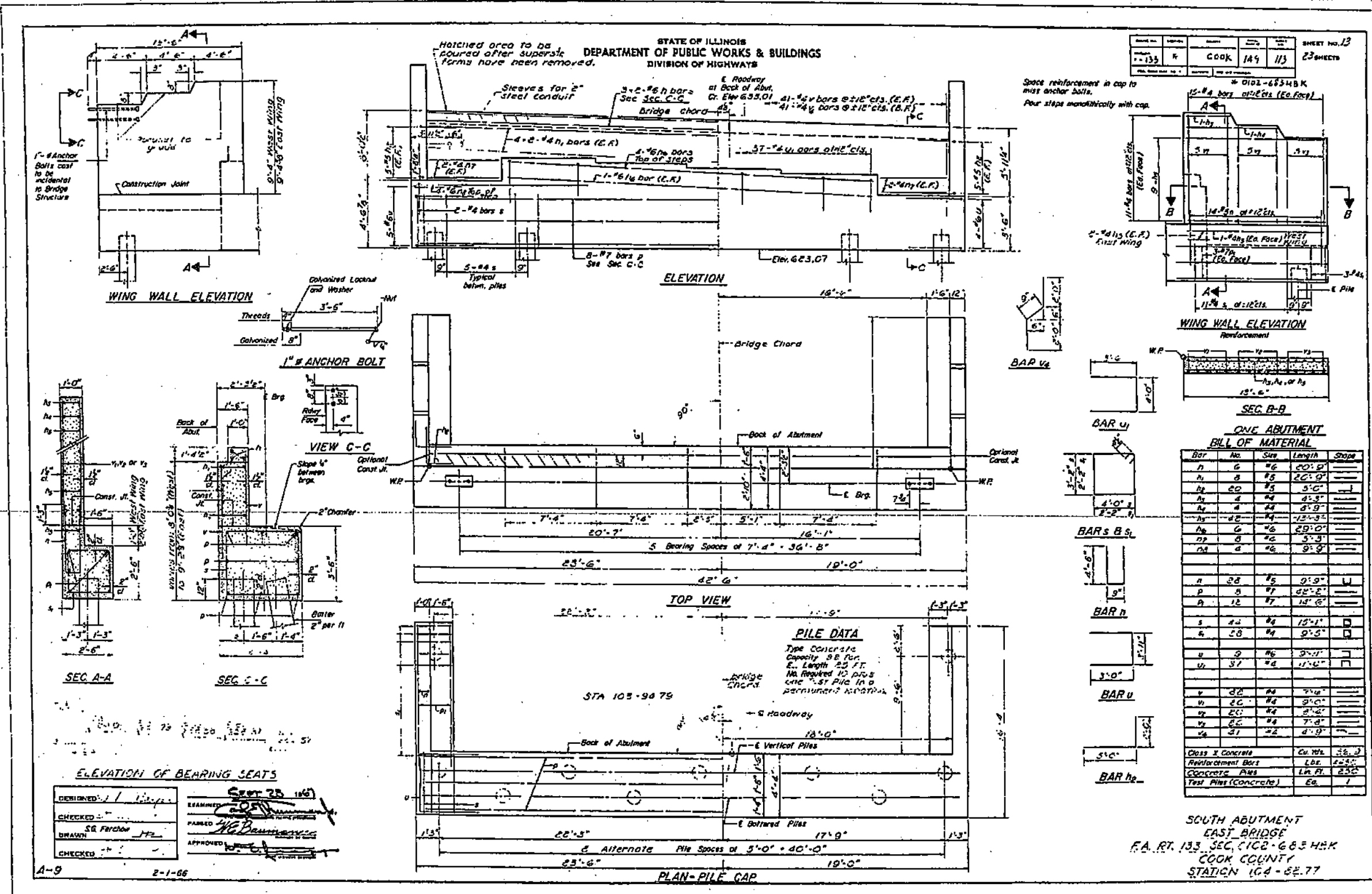

DESIGNED: J. J. [Signature]  
CHECKED: [Signature]  
DRAWN: S. G. [Signature]  
APPROVED: [Signature]

DATE: 2-1-66

STATE OF ILLINOIS  
DEPARTMENT OF PUBLIC WORKS & BUILDINGS  
DIVISION OF HIGHWAYS

|          |     |     |      |     |     |              |
|----------|-----|-----|------|-----|-----|--------------|
| WORK NO. | 103 | NO. | COOK | 149 | 114 | SHEET NO. 14 |
| DATE     |     |     |      |     |     | 23 SHEETS    |

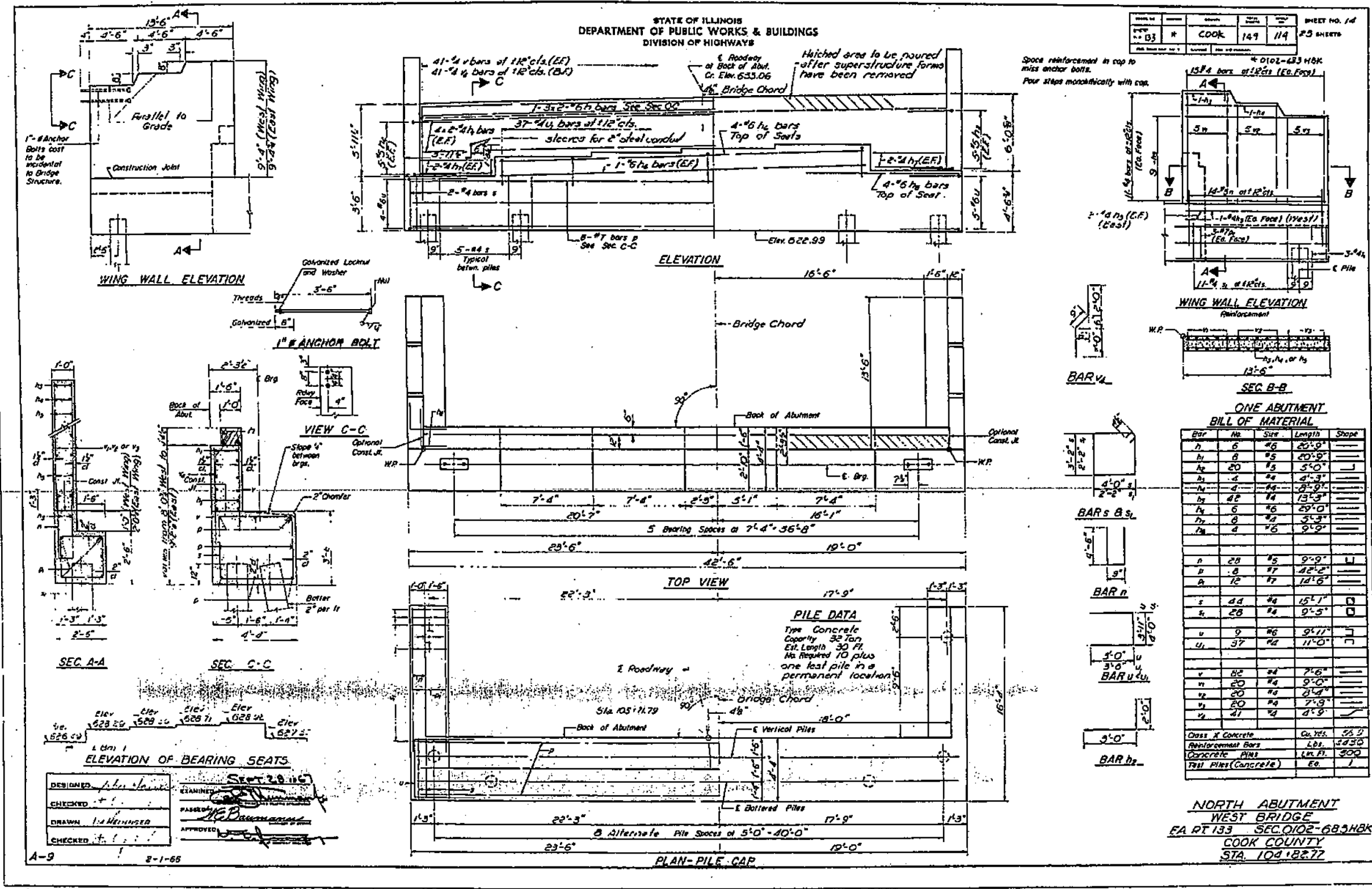

STATE OF ILLINOIS  
DEPARTMENT OF PUBLIC WORKS & BUILDINGS  
DIVISION OF HIGHWAYS

SHEET NO. 15  
193 R COOK 149 115

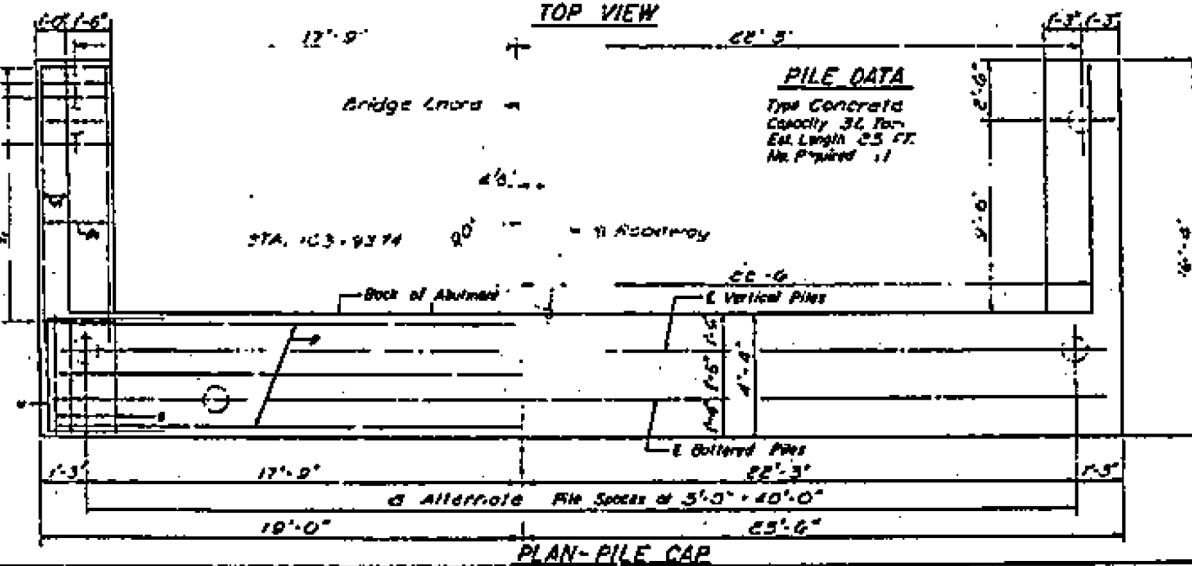
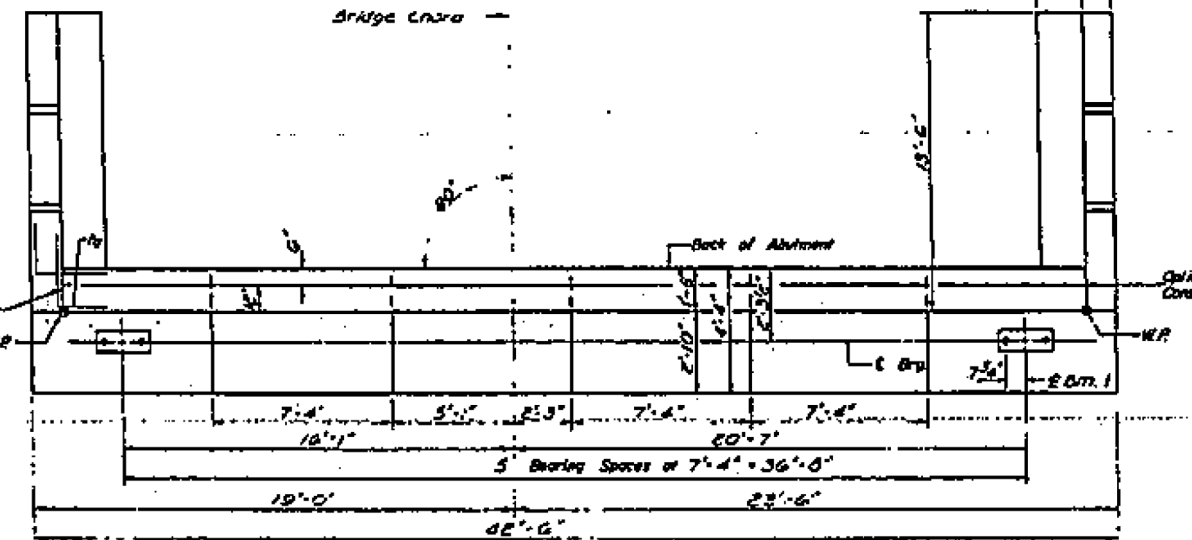
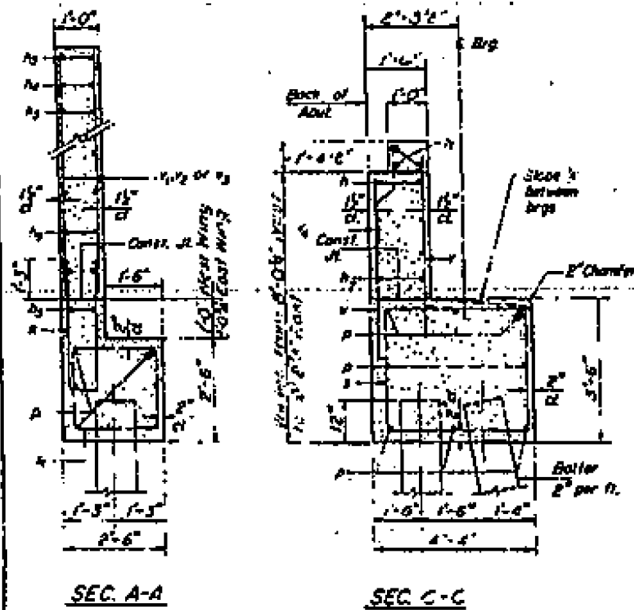
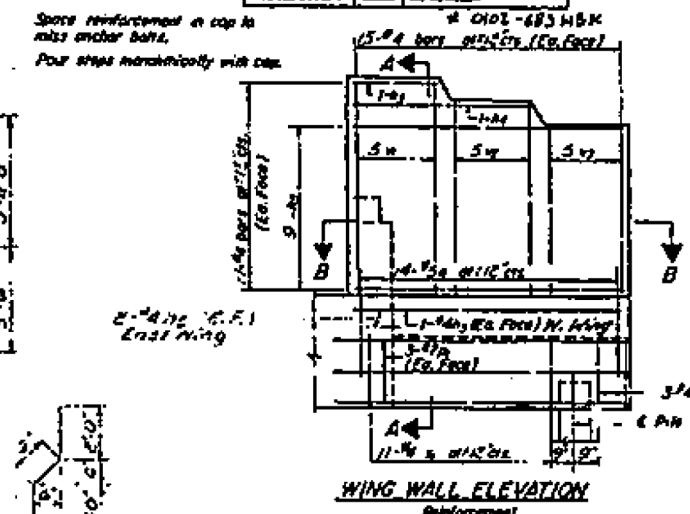
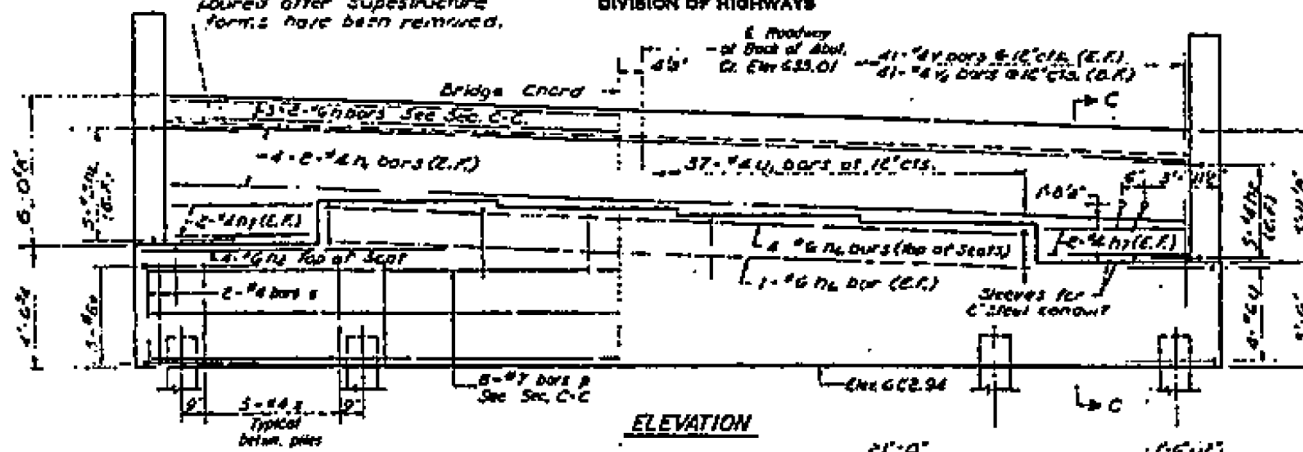
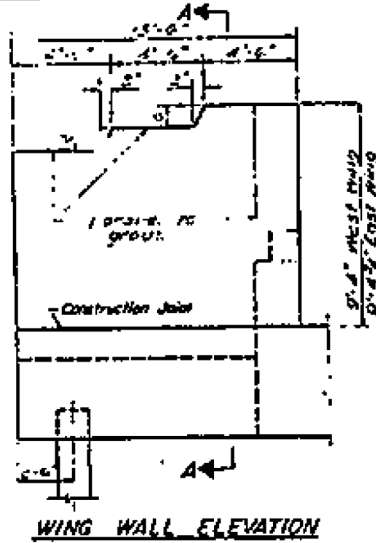

PILE DATA  
Type Concrete  
Capacity 36 Ton.  
Est. Length 25 FT.  
No. Piles 11

SEC. B-B  
ONE ABUTMENT  
BILL OF MATERIAL

| BAR                | No. | Size     | Length | Shape |
|--------------------|-----|----------|--------|-------|
| N                  | 6   | #5       | 20'-0" |       |
| N                  | 6   | #5       | 20'-0" |       |
| N                  | 20  | #5       | 5'-0"  |       |
| N                  | 4   | #4       | 4'-3"  |       |
| N                  | 4   | #4       | 8'-9"  |       |
| N                  | 22  | #4       | 13'-9" |       |
| N                  | 6   | #6       | 29'-0" |       |
| N                  | 6   | #6       | 5'-9"  |       |
| N                  | 4   | #6       | 5'-9"  |       |
| N                  | 28  | #5       | 9'-9"  | U     |
| N                  | 6   | #7       | 42'-0" |       |
| N                  | 10  | #7       | 14'-0" |       |
| N                  | 42  | #4       | 15'-1" |       |
| N                  | 20  | #4       | 9'-5"  |       |
| N                  | 9   | #6       | 9'-11" |       |
| N                  | 37  | #4       | 11'-0" |       |
| N                  | 32  | #4       | 7'-0"  |       |
| N                  | 20  | #4       | 8'-0"  |       |
| N                  | 20  | #4       | 8'-0"  |       |
| N                  | 20  | #4       | 7'-8"  |       |
| N                  | 31  | #4       | 8'-2"  |       |
| Cost of Concrete   |     | cu. Yds. | 26.7   |       |
| Reinforcement Bars |     | Lbs.     | 4425   |       |
| Concrete Pks       |     | Lbs.     | 172    |       |

SOUTH ABUTMENT  
WEST BRIDGE  
R.A. RT. 133, SEC. 0102-603 H&K  
COOK COUNTY  
STATION 104+82.77

DESIGNED: John Hays  
CHECKED: SG Farshaw Jr.  
DRAWN: SG Farshaw Jr.  
APPROVED: [Signature]

DATE: 2-1-65