

SIGN TABLE

SIGN	DIMENSIONS
R10-3b	9" (228mm) X 12" (305mm)
R10-3d	9" (228mm) X 12" (305mm)
R10-3e	9" (228mm) X 15" (381mm)

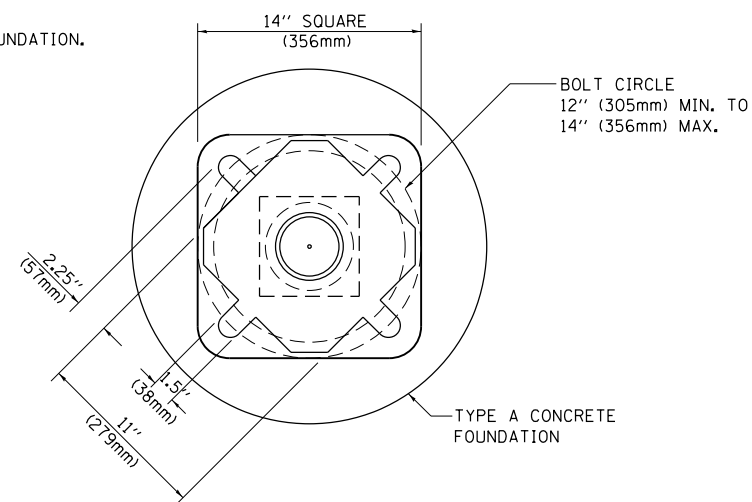

BOLT PATTERN

PEDESTRIAN PUSH BUTTON POST, TYPE A

FILE NAME =	USER NAME = paraynoal	DESIGNED - DAG	REVISED - DAG 1-1-14
et:\pw\work\pwidot\paraynoal\0246802\01std.dgn		DRAWN - GND	REVISED -
	PLOT SCALE = 100.0000' / 1"	CHECKED - DAD	REVISED -
	PLOT DATE = 7/16/2014	DATE - 10/1/2012	REVISED -

**STATE OF ILLINOIS
DEPARTMENT OF TRANSPORTATION**

DISTRICT ONE STANDARD TRAFFIC SIGNAL DESIGN DETAILS			
SCALE: NONE	SHEET NO. 7 OF 7 SHEETS	STA.	TO STA.

F.A.U. RTE.	SECTION	COUNTY	TOTAL SHEETS	SHEET NO.
1602	74-RS-2	COOK	32	31
TS-05			CONTRACT NO.	
FED. ROAD DIST. NO. 1 ILLINOIS FED. AID PROJECT				