

KIRCHOFF RD

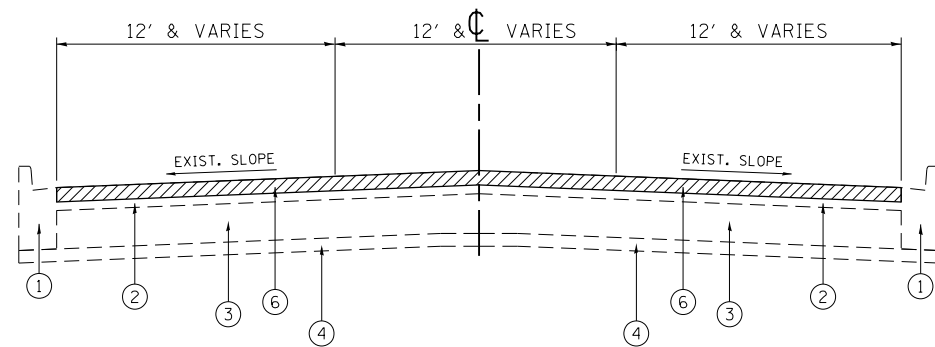

EXISTING TYPICAL SECTION

STA. 7+80 TO 62+65.4

LEGEND

- ① EXISTING COMBINATION CONCRETE CURB AND GUTTER, TYPE B-6.24
- ② EXISTING HMA SURFACE COURSE, 3 1/4" (±)
- ③ EXISTING HMA BASE COURSE, 10" (±)
- ④ EXISTING SUB-BASE GRANULAR MATERIAL, TYPE B - 4"
- ⑤ EXISTING CORRUGATED CONCRETE MEDIAN

- ⑥ PROPOSED HOT-MIX ASPHALT SURFACE REMOVAL - 2 1/4"
- ⑦ PROPOSED COMBINATION CONCRETE CURB AND GUTTER REMOVAL AND REPLACEMENT (LOCATIONS TO BE DETERMINED BY THE RESIDENT ENGINEER)
- ⑧ PROPOSED HOT-MIX ASPHALT SURFACE COURSE, MIX "D", N70 - 1 1/2"
- ⑨ PROPOSED POLYMERIZED LEVELING BINDER (MACHINE METHOD), IL-4.75, N50 - 3/4"

NOTES:

- 1. MILLING SHALL BE DONE PRIOR TO PATCHING OF THE ROADWAY.

KIRCHOFF RD

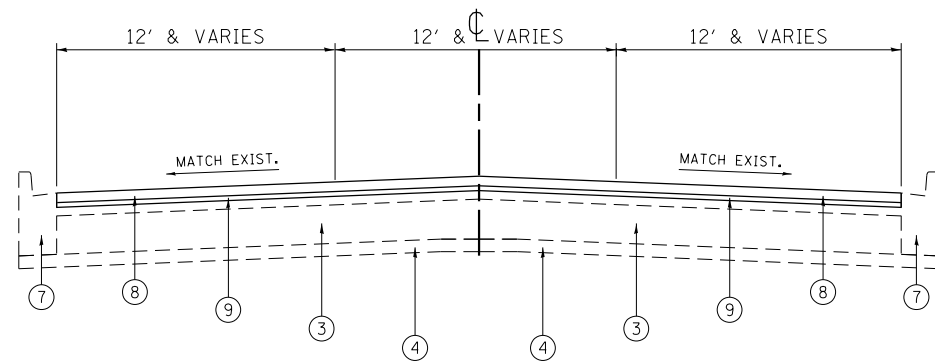

PROPOSED TYPICAL SECTION

STA. 7+80 TO 62+65.4

FILE NAME =	USER NAME = Tariqfm	DESIGNED -	REVISED -	STATE OF ILLINOIS DEPARTMENT OF TRANSPORTATION	EXISTING AND PROPOSED TYPICAL SECTIONS KIRCHOFF RD. (NEW WILKE RD. TO CENTRAL AVE.)	F.A.U. RTE.	SECTION	COUNTY	TOTAL SHEETS	SHEET NO.
et:\pwork\pwork\tdot\tariqfm\d0241225\0109011-sht-plan.dgn	DRAWN -	REVISED -	3518			0405.2-RS	COOK	24	6	
PLOT SCALE = 100.0000' / in.	CHECKED -	REVISED -	CONTRACT NO. 60M23							
PLOT DATE = 7/11/2014	DATE -	REVISED -	ILLINOIS FED. AID PROJECT							
				SCALE:	SHEET NO. OF SHEETS	STA. TO STA.				