

PLAN - ENTRANCE TERMINAL

INTERCHANGE	RAMP	ADJACENT MAINLINE	STA A		STA B	
			RAMP	MAINLINE	RAMP	MAINLINE
BUS 55	A	NB I-55	29+45	718+31	31+76	720+56
BUS 55	C	SB I-55	N/A	N/A	17+57	704+76

INTERCHANGE	RAMP	ADJACENT MAINLINE	STA A		STA B	
			RAMP	MAINLINE	RAMP	MAINLINE
ATLANTA (CH# 6)	B	SB I-55	9+74	483+52	11+74	481+52
ATLANTA (CH# 6)	D	NB I-55	9+83	509+28	11+83	511+28

LEGEND

- 1 EX STABILIZED SUB-BASE
- 2 EX PCC BASE COURSE
- 3 EX PCC PAVEMENT
- 4 EX HOT-MIX ASPHALT SHOULDER
- 5 EX HOT-MIX ASPHALT
- 6 PR HOT-MIX ASPHALT SURFACE REMOVAL 1 1/2"
- 7 PR HOT-MIX ASPHALT SURFACE REMOVAL 2"
- 8 PR HOT-MIX ASPHALT SURFACE REMOVAL 3 1/4"
- 9 PR HOT-MIX ASPHALT SURFACE REMOVAL 4 3/4"
- 10 PR POLYMERIZED HOT-MIX ASPHALT BINDER COURSE, IL-19.0, N105 2 1/4"
- 11 PR POLYMERIZED HOT-MIX ASPHALT BINDER COURSE, IL-19.0, N105 3 1/4"
- 12 PR POLYMERIZED HOT-MIX ASPHALT SURFACE COURSE, MIX "E", N105 1 1/2"
- 13 PR HOT-MIX ASPHALT SURFACE COURSE, MIX C, N50 2"

\* MATCH EXIST SLOPE

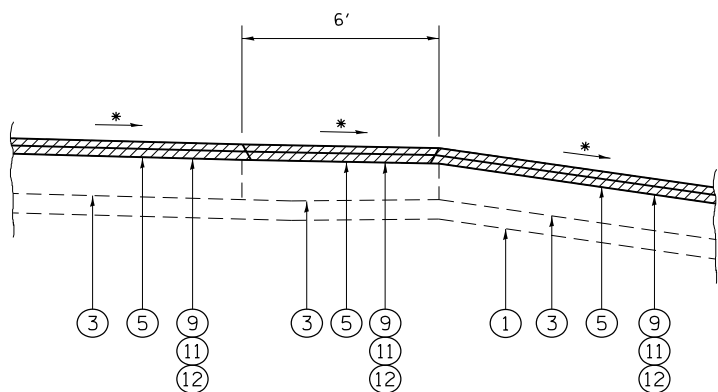

SECTION A-A  
(RAMP A)

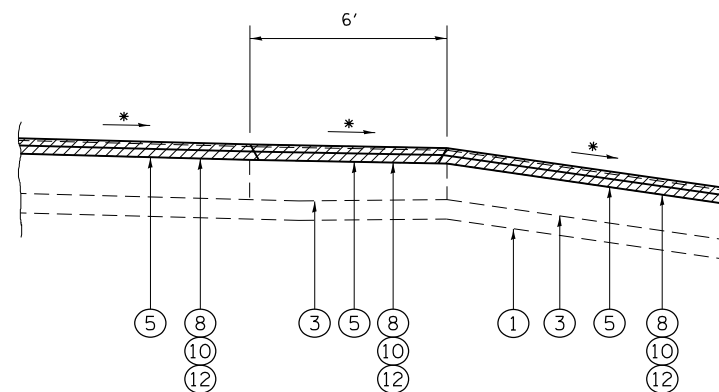

SECTION A-A  
(RAMP C)