

TYPICAL SECTION (IL 161)

M.P. 4.99 TO M.P. 5.10

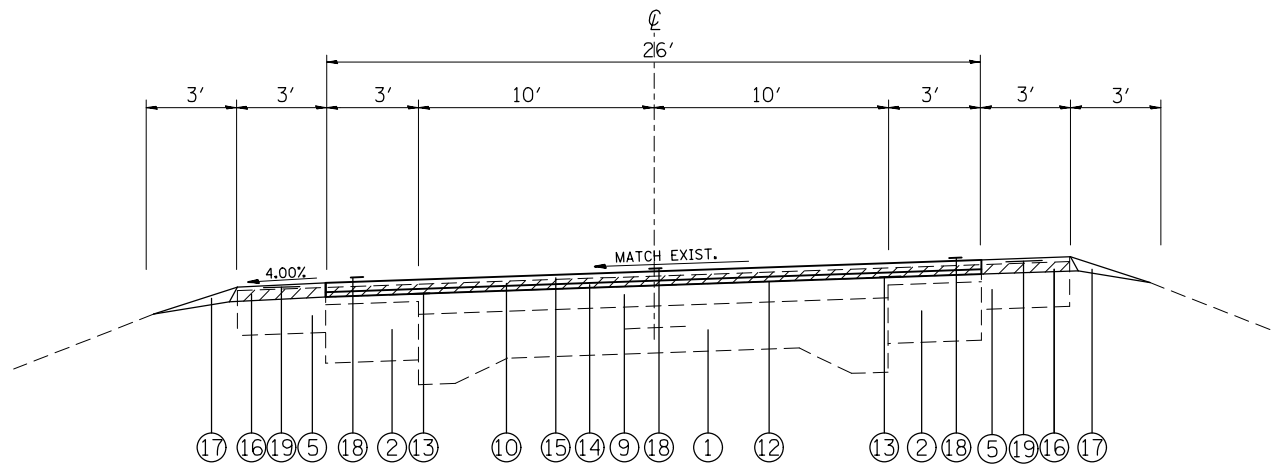

TYPICAL SECTION (IL 161)

M.P. 4.41 TO M.P. 4.64

M.P. 4.81 TO M.P. 4.99

LEGEND

- ① EXISTING PCC PAVEMENT 6"-9"-6"
- ② EXISTING HMA BASE COURSE WIDENING 9"
- ③ EXISTING HMA BASE COURSE WIDENING 8"
- ④ EXISTING PCC BASE COURSE WIDENING 7"
- ⑤ EXISTING HMA SHOULDERS 6"
- ⑥ EXISTING HMA SHOULDERS 8"
- ⑦ EXISTING CURB & GUTTER, TYPE B-6.24
- ⑧ EXISTING HMA RESURFACING ± 5"
- ⑨ EXISTING HMA RESURFACING ± 7 1/2"
- ⑩ PROPOSED HMA SURFACE REMOVAL, VARIABLE DEPTH
- ⑪ PROPOSED HMA SURFACE REMOVAL 2 1/4"
- ⑫ PROPOSED BITUMINOUS MATERIALS (PRIME COAT)
- ⑬ PROPOSED STRIP REFLECTIVE CRACK CONTROL TREATMENT
- ⑭ PROPOSED LEVELING BINDER (MACHINE METHOD), 3/4"
- ⑮ PROPOSED HMA SURFACE COURSE, MIX D, N70 1 1/2"
- ⑯ PROPOSED HMA SHOULDERS, 2 1/4"
- ⑰ PROPOSED AGGREGATE WEDGE SHOULDER, TYPE B
- ⑱ PROPOSED THERMOPLASTIC PAVEMENT MARKING
- ⑲ PROPOSED SHOULDER RUMBLE STRIPS, 8"

FILE NAME =	USER NAME = dntelmenjn	DESIGNED -	REVISED -
et:\pw\work\p\dot\dntelmenjn\1\0332010\0876631-sh1-pln.dgn		DRAWN -	REVISED -
	PLOT SCALE = 100.0000' / in.	CHECKED -	REVISED -
	PLOT DATE = 6/25/2014	DATE -	REVISED -

**STATE OF ILLINOIS
DEPARTMENT OF TRANSPORTATION**

TYPICAL SECTIONS

SCALE: SHEET NO. 2 OF 4 SHEETS STA. TO STA.

F.A.P. RTE.	SECTION	COUNTY	TOTAL SHEETS	SHEET NO.
805	3RS-1,(5,7-1)RS-3	CLINTON	26	8
FED. ROAD DIST. NO. ILLINOIS FED. AID PROJECT			CONTRACT NO. 76G31	