

TYPE I ELASTOMERIC EXP. BRG. AT PIERS 1 & 4
(22 Required)

TYPE II ELASTOMERIC EXP. BRG. AT ABUT.
(22 Required)

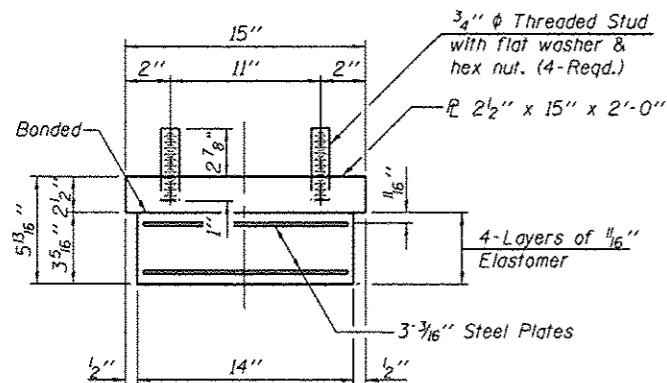

BEARING ASSEMBLY

Note:
Shim plates shall not be placed under Bearing Assembly.

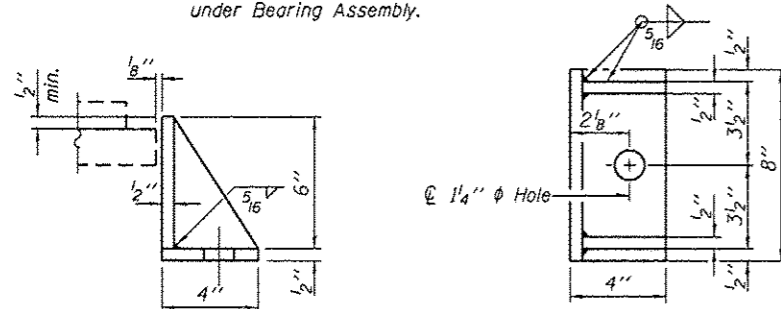

SIDE RETAINER

Equivalent rolled angle with stiffeners will be allowed in lieu of welded plates.

BILL OF MATERIAL

Item	Unit	Total
Elastomeric Bearing Assembly, Type I	Each	22
Elastomeric Bearing Assembly, Type II	Each	22
Anchor Bolts, 3/4"	Each	44
Anchor Bolts, 1"	Each	44

NOTES

- Anchor bolts shall be ASTM F1554 all-thread (or an Engineer-approved alternate material) of the grade(s) and diameter(s) specified. The corresponding specified grade of AASHTO M314 anchor bolts may be used in lieu of ASTM F1554.
- Anchor bolts for side retainers for Type I bearings may be cast in place or installed in holes drilled before or after members are in place.
- Anchor bolts for Type II bearings shall be placed in holes drilled in the concrete through holes in the bottom bearing plate after members are in place. Side retainers shall be placed after bolts are installed.
- Drilled and set anchor bolts shall be installed according to Article 521.06 of the Standard Specifications.
- Side retainers and other steel members required for the elastomeric bearing assembly shall be included in the cost of Elastomeric Bearing Assembly, Type I or Type II.
- The structural steel plates of the Bearing Assembly shall conform to the requirements of AASHTO M 270 Grade 50.
- The 1/8" PTFE sheet shall be bonded directly to the top steel plate with a two-component, medium viscosity epoxy resin, conforming to the requirements of the Federal Specification MMM-A-134, Type I. The bond agent shall be applied on the full area of the contact surfaces.
- Bonding of 1/8" PTFE sheet during vulcanizing process will be permitted provided the process and method of adjusting assembly height is approved by the Engineer.
- Two 1/8 in. adjusting shims shall be provided for each bearing in addition to all other plates or shims and placed as shown on bearing details.
- All bearings plates, side retainers, anchor bolts, nuts, washers and pintles shall be galvanized according to AASHTO M111 or M232 as applicable.

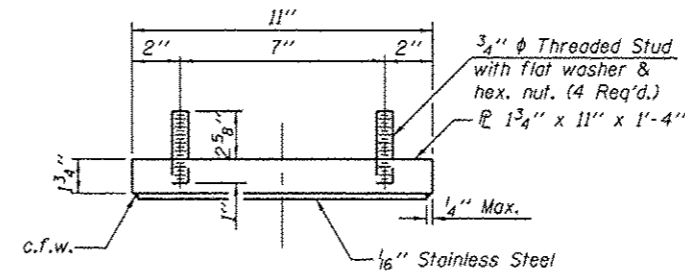

TOP BEARING ASSEMBLY

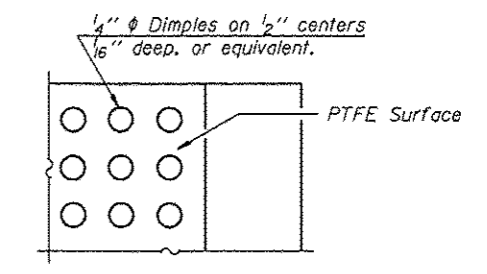

PLAN-PTFE SURFACE

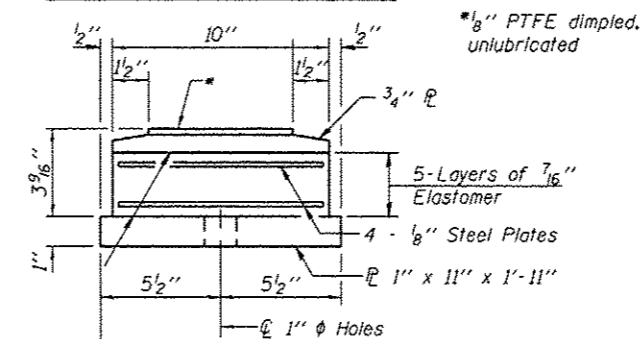

BOTTOM BEARING ASSEMBLY

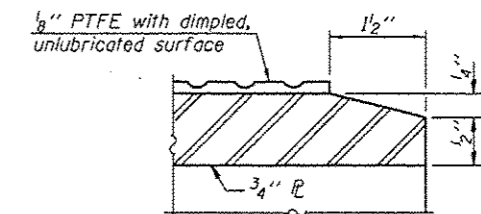

SECTION THRU PTFE

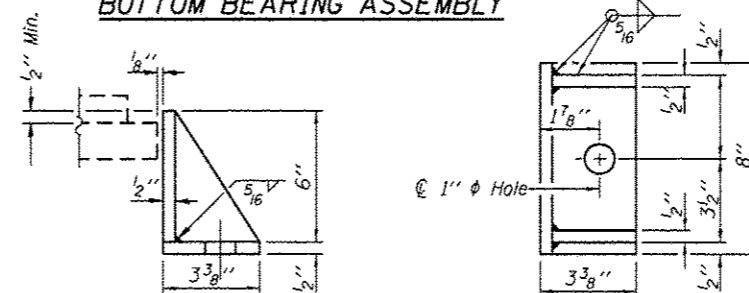

SIDE RETAINER

Equivalent rolled angle with stiffeners will be allowed in lieu of welded plates.

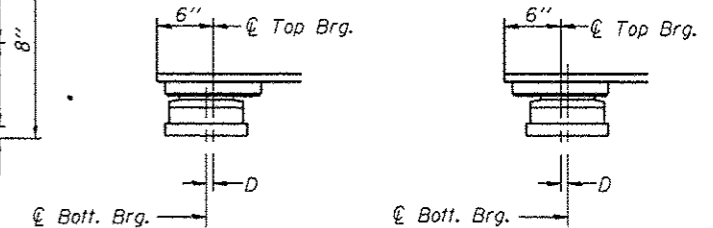

BELOW 50°F. (Move bott. brg. away from fixed brg.)
ABOVE 50°F. (Move bott. brg. toward fixed brg.)

SETTING ANCHOR BOLTS AT EXP. BRG.

D = 1/8" per each 100' of expansion for every 15° temp. change from the normal temp. of 50°F.

H:\jobs\2011\201103022\CAD\Structural\dgm\016-1149_Final\00\060J05-s29-exp-brg-dt.dgn 5/20/2013 10:24:09 AM

GR&E

8501 W. Higgins Road Suite 280
Chicago, Illinois 60631 (773) 399-0112

USER NAME :	DESIGNED - J.Z.	REVISED -
PLOT SCALE :	CHECKED - J.A.Z.	REVISED -
PLOT DATE :	DRAWN - E.E.J.	REVISED -
	DATE - 5/17/2013	REVISED -

**STATE OF ILLINOIS
DEPARTMENT OF TRANSPORTATION**

**EXPANSION BEARINGS DETAILS
STRUCTURE NO. 016-1149**

SHEET NO. S29 OF 50 SHEETS

F.A.I. RTE.	SECTION	COUNTY	TOTAL SHEETS	SHEET NO.
94	1920-B	COOK	137	88

CONTRACT NO. 60J15
ILLINOIS FED. AID PROJECT