

**GENERAL NOTES**

Any reinforcement bars that are damaged during concrete removal operations shall be repaired or replaced using an approved bar splicer or anchorage system. Cost included with "Concrete Removal".

Existing reinforcement shall be cleaned and incorporated into the new construction. Cost included with Concrete Removal.

Plan dimensions and details relative to existing plans are subject to nominal construction variations. The Contractor shall field verify existing dimensions and details affecting new construction and make necessary approved adjustments prior to construction or ordering of materials. Such variations shall not be cause for additional compensation for a change in scope of the work, however, the Contractor will be paid for the quantity actually furnished at the unit price bid for the work.

Reinforcement bars designated (E) shall be epoxy coated.

Joint openings shall be adjusted according to Article 520.04 of the Standard Specifications when the deck is poured at an ambient temperature other than 50°F.

Prior to pouring the new concrete deck, all heavy or loose rust, loose mill scale, and other loose or potentially detrimental foreign material shall be removed from the surfaces in contact with concrete. Tightly adhered paint may remain unless otherwise noted. Removal shall be accomplished by methods that will not damage the steel and the cost will be included in the pay item covering removal of the existing concrete.

As directed by the Engineer, existing construction accessories welded to the top flange of beams and girders shall be removed. The weld areas shall be ground flush and inspected for cracks using magnetic particle testing (MT) or dye penetrant testing (PT) by qualified personnel approved by the Engineer.

Any cracks that cannot be removed by grinding 1/4 inch deep shall be identified and reported to the Bureau of Bridges and Structures for further disposition.

The cost of removing welded accessories, grinding and inspecting weld areas and grinding cracks will be paid for according to Article 109.04 of the Standard Specifications.

The existing structural steel coating contains lead. The Contractor shall take appropriate precautions to deal with the presence of lead on this project.

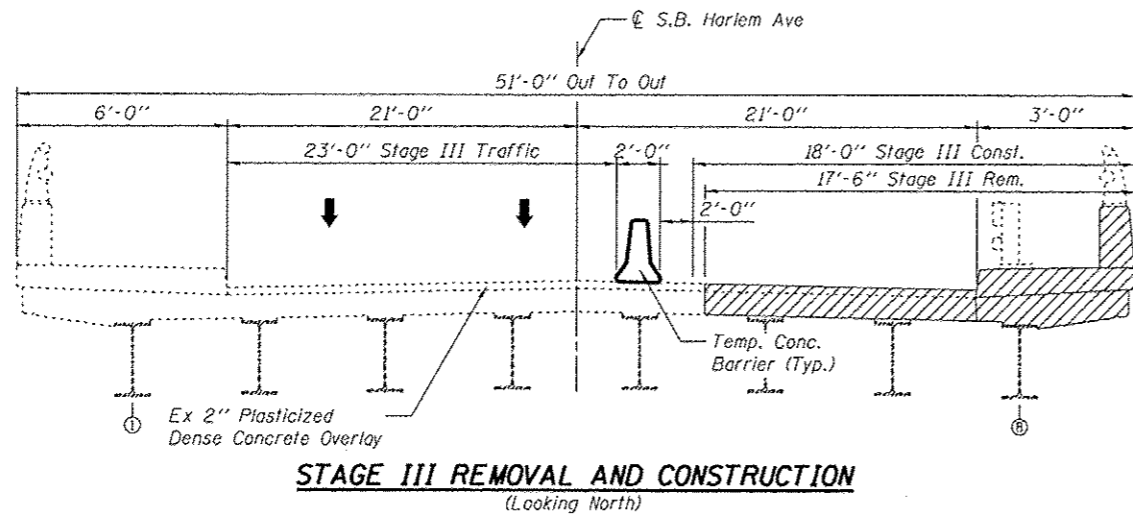
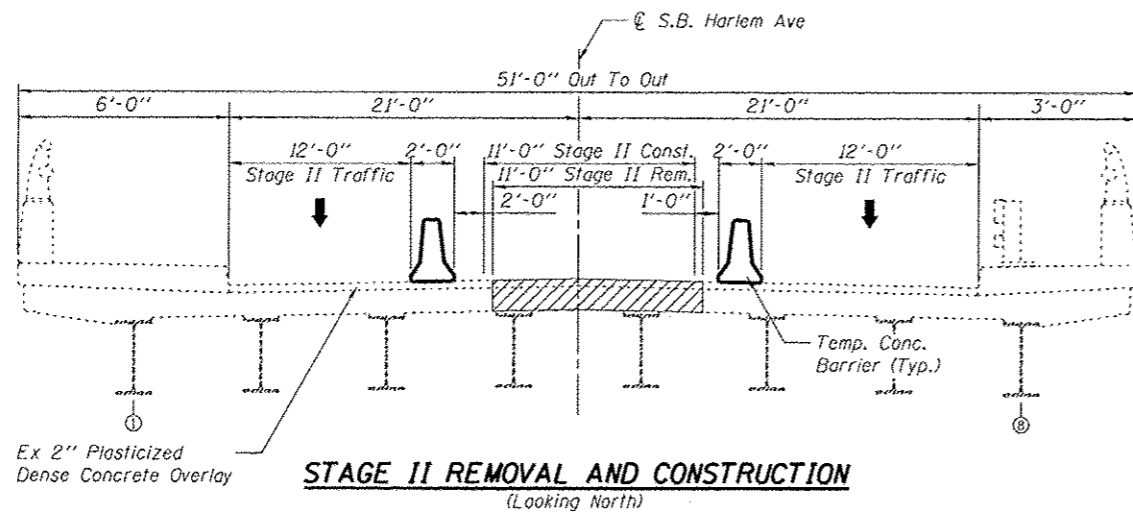
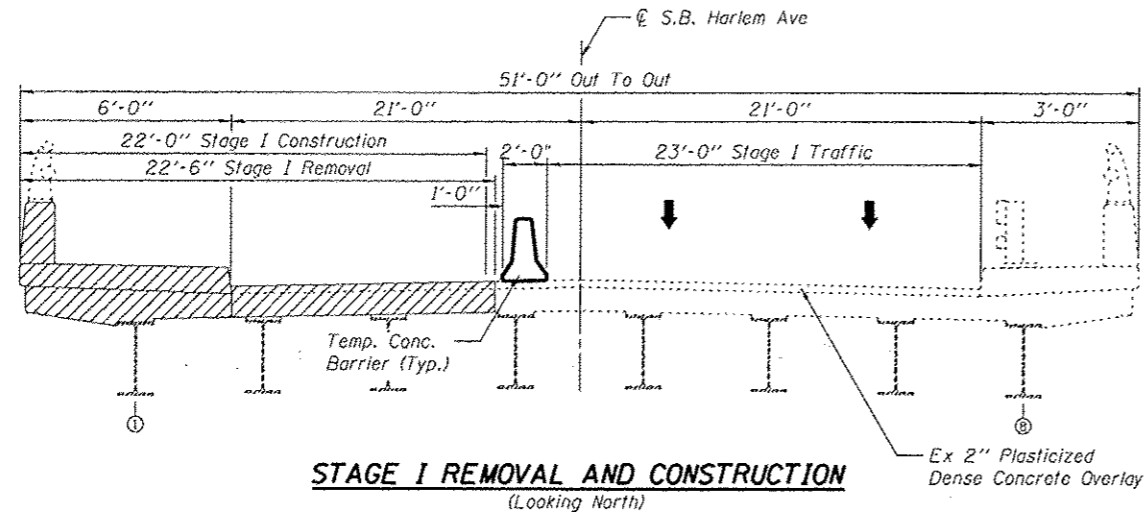

Note:  
Hatched area indicates concrete removal

PRINTED DATE: 8/8/2013  
FILE NAME: K:\Projects\1101\1101-13 Harlem over MRRDC RRU\CD\Drawn\20130802 Revised Final Plans and Docs to 1101.CD\Sheet\0102412-09107-002-00E\_2.dgn



USER NAME - #USER#	DESIGNED - JEH	REVISED - 08/08/2013
PLOT SCALE - 2.0000' = 1"	CHECKED - DF	REVISED -
PLOT DATE - 8/8/2013	DRAWN - JEH	REVISED -
	CHECKED - DF	REVISED -

STATE OF ILLINOIS  
DEPARTMENT OF TRANSPORTATION

GENERAL DATA & STAGE CONSTRUCTION DETAILS  
STRUCTURE NO. 016-2412

F.A.P. RTE.	SECTION	COUNTY	TOTAL SHEETS	SHEET NO.
348	0708.3A-BR(11)	COOK	25	10
CONTRACT NO. 60T07			ILLINOIS FED. AID PROJECT	

SHEET NO 2 OF 12 SHEETS