

LOCATION 10: I-55 (STEVENS ON EXPRESSWAY), NB
 1 MILE NORTH OF BLACK RD. OVERPASS, RIGHT SIDE

PANEL SCHEDULE (TOP)					
MARK	PANEL HEIGHT	PANEL WIDTH	QUANTITY	AREA EACH(S.F)	AREA TOTAL(S.F)
3T-1	10'-0"	20'-4"	2	203.3	406.6
PANEL SCHEDULE (BOTTOM)					
3B-6	2'-6"	20'-4"	1	50.8	50.8

**CITY OF JOLIET
 TROY TOWNSHIP
 WILL COUNTY**

TRAFFIC DATA:
 SPEED LIMIT: 65 MPH
 2012 ADT: 75600

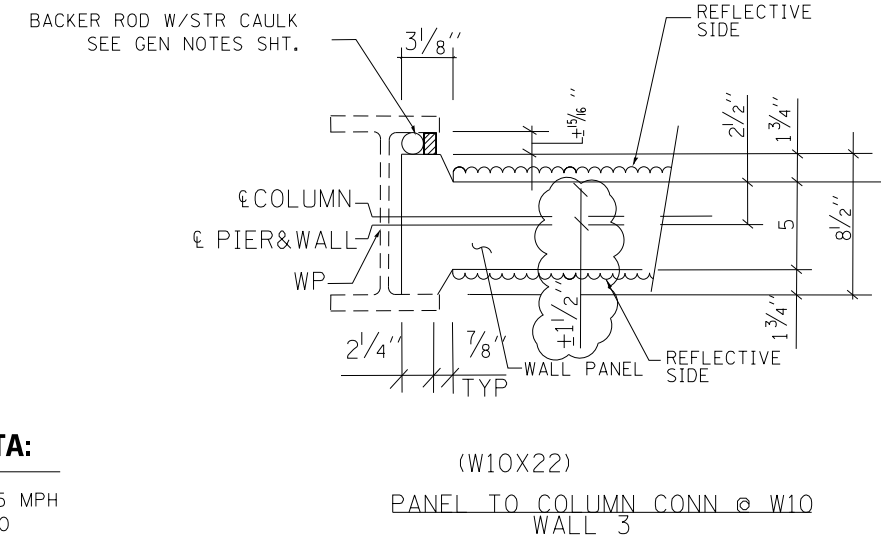

BILL OF MATERIAL

ITEM	UNIT	QUANTITY
CONCRETE REMOVAL	Cu. Yds.	4.4
NOISE ABATEMENT WALL REPAIRS	Lump Sum	1

AREA OF REPAIR= 255 SQ FT



NOISE ABATEMENT WALL REPAIR
 REPLACE PANELS
 FOR MORE DETAILS, SEE SHEET #26

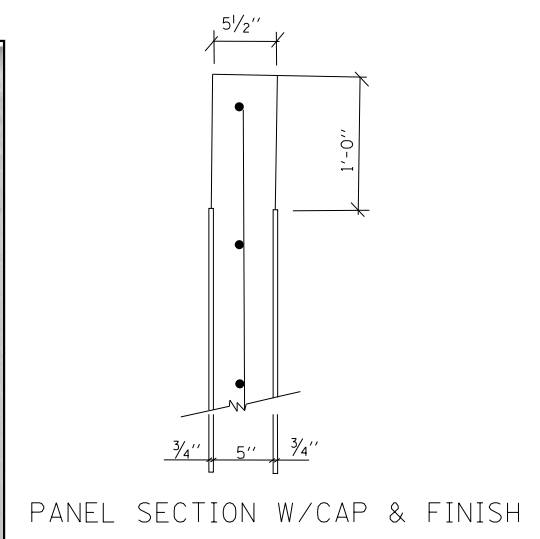

PANEL SECTION W/CAP & FINISH

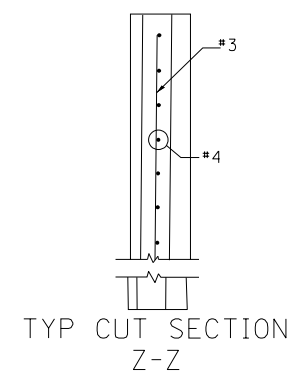

TYP CUT SECTION Z-Z

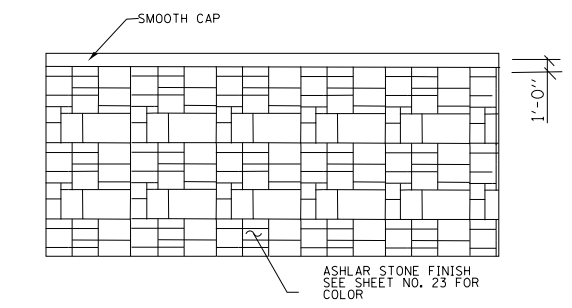

TYPICAL PANEL DETAIL W/ FINISH

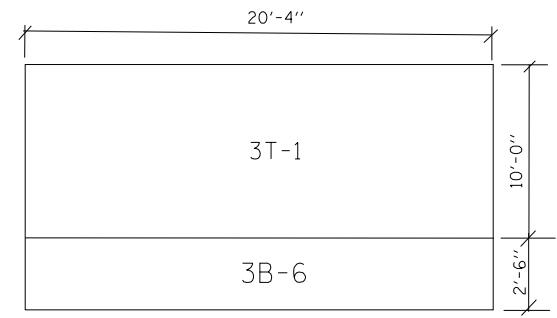

TYPICAL PANEL DETAIL

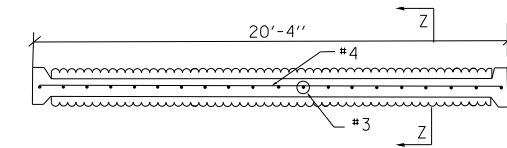

TYPICAL WALL PLAN