

DETAIL C

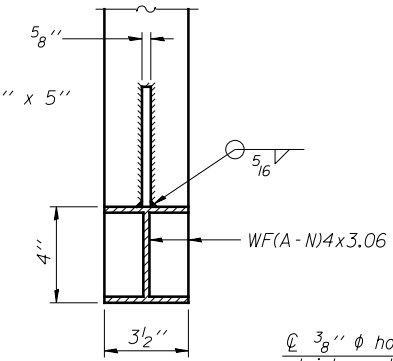

SECTION C-C

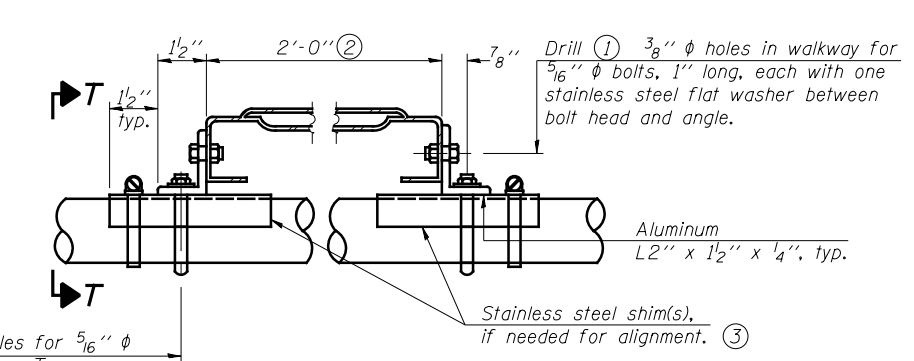

DETAIL T

(Truss grating at horizontal)

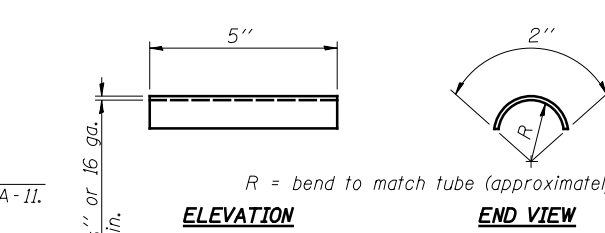

SHIM DETAIL

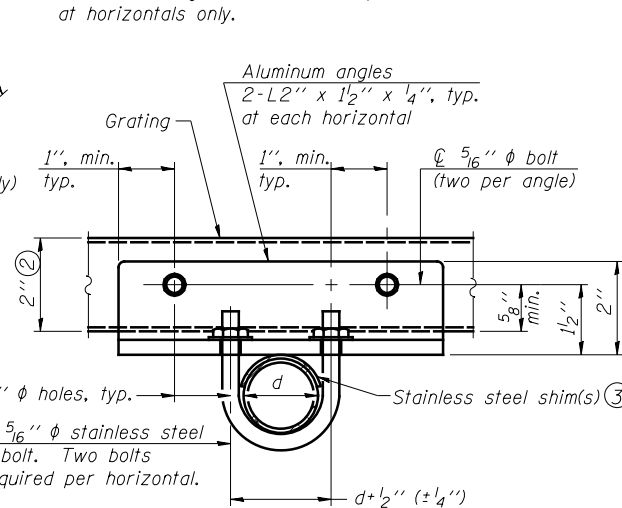

SECTION T-T

(Truss Grating Continuous)

d = outside diameter of horizontal

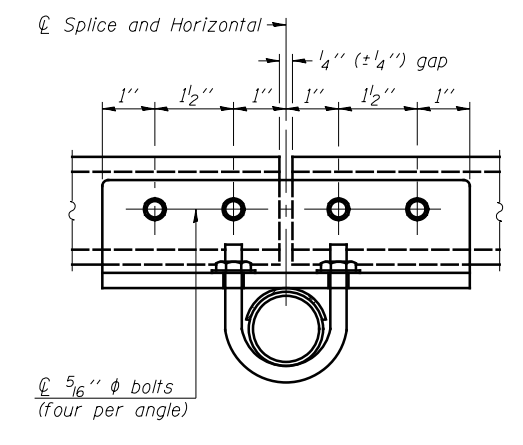

SECTION T-T

(Truss Grating Splice)

Alternate splice details and locations may be used subject to the Engineer's review and approval.

Sign shall be even with the top of the bracket, but it may extend no more than 6" above the top of the bracket for field adjustments.

SECTION B-B

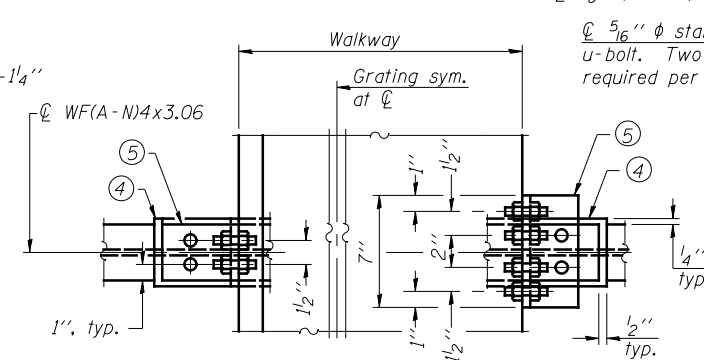

WALKWAY GRATING CONTINUOUS AT WALKWAY GRATING SPLICE

SECTION W-W

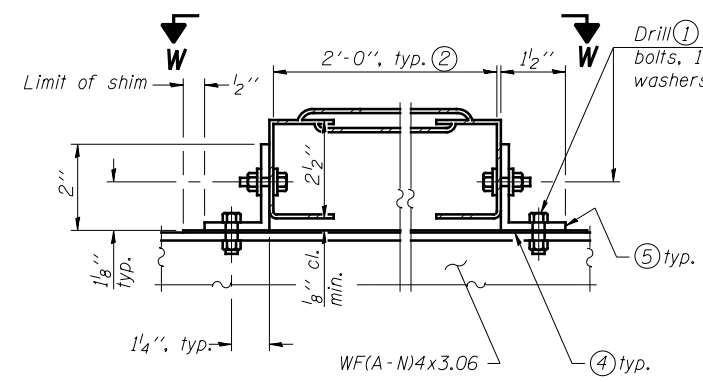

DETAIL W
GALVANIZED STEEL WALKWAY GRATING

- (1) Drilling holes in grating may be done in shop or field, based on Contractor's preference and subject to accurate alignment.
- (2) Perforated or expanded metal grating providing a skid resistant (non-serrated) surface and capable of supporting a 500 pound concentrated load with a 6'-0" clear span. Walkway and truss grating dimensions are nominal and may vary (width ±2", depth ±2") based on available standard sizes. Cut ends of grating shall be free of burrs or hazardous projections and coated with zinc-rich primer or equivalent.
- (3) Stainless steel shims shall be placed under angles at horizontals and horizontal diagonals if needed to compensate for alignment variations and differences in horizontal diagonal pipe sizes beyond adjustment provided by angles. Secure with one stainless steel clamp per location, see "Shim Detail". Thicker shim plates may be used when needed subject to shims performing properly.
- (4) 1/16" (or 16 ga.) x 2 1/2" x 4" stainless steel shim adhered to top of WF(A-N)4x3.06 beneath each galvanized angle. Adhesives for shims shall be suitable for materials joined and full exposure conditions.
- (5) Galvanized steel L2" x 2" x 1/4", 3 1/2" long with continuous grating, 7" long at grating splice.
- (6) Details shown are considered equal alternatives to the Aluminum Walkway on Base Sheet OS-A-10 and may be substituted by Contractor at no change in contract cost.
- (7) 1/8" x 1/2" x 2" welded to handrail posts to protect locations that contact grating.
- (8) Based on actual height of tallest sign given on OS-A-1.

ALUMINUM TRUSS GRATING

Structure Number	Station	A	(8) B	C	(8) D
7S025I057R162.0	2290+50	5 1/2"	6'-6"	4'-6"	11'-6"
7S025I057R162.7	2326+30	5 1/2"	4'-9"	4'-6"	9'-9"
7S025I057R163.4	2351+00	5 1/2"	4'-0"	4'-6"	9'-0"
7S025I070L098.6	2387+00	5 1/2"	4'-6"	4'-6"	9'-6"
7S025I070L099.1	2412+00	5 1/2"	4'-9"	4'-6"	9'-9"

OS-A-10S

6-1-12

FILE NAME =	USER NAME =	DESIGNED - ESW	REVISED -
		CHECKED - JWS	REVISED -
		DRAWN - PDB	REVISED -
		CHECKED - BRM	REVISED -

STATE OF ILLINOIS
DEPARTMENT OF TRANSPORTATION

OVERHEAD SIGN STRUCTURES
ALTERNATE WALKWAY DETAILS

SHEET NO. 33 OF 53 SHEETS

F.A.I. RTE.	SECTION	COUNTY	TOTAL SHEETS	SHEET NO.
57/70	(25-4R)	EFFINGHAM	1760	420
ILLINOIS FED. AID PROJECT			CONTRACT NO. 74295	